

APPENDIX A

Amendments to OAC Chapter 3745-21 (VOC RACT)

Effective March 27, 2022, Ohio EPA adopted revisions to Ohio Administrative Code (OAC) Chapter 3745-21 to adopt mandatory Reasonably Available Control Technology (RACT) requirements for Cincinnati and Cleveland 2015 ozone nonattainment areas.

The Cleveland and Cincinnati nonattainment areas are currently classified as marginal nonattainment for the 2015 ozone standard. The areas were required to meet the ozone standard by August 3, 2021, based on ozone monitoring data collected during the 2018-2020 ozone monitoring seasons, which extend from March 1 to October 31 each year. The Cleveland and Cincinnati areas failed to meet the ozone standard during the 2018-2020 ozone monitoring seasons as required and Ohio EPA anticipates that the areas will be reclassified to moderate nonattainment by U.S. EPA in accordance with the Clean Air Act (CAA).

Reclassification to moderate nonattainment triggers additional CAA requirements, including VOC RACT requirements. This includes adoption of U.S. EPA Control Technique Guidelines (CTGs) as well as non-CTG VOC RACT for major stationary sources located in the moderate nonattainment areas. Some CTGs and non-CTG VOC RACT were previously adopted under prior ozone standards.

Ohio EPA has also made minor revisions to these rules as needed for clarification and agency and state formatting protocols.

At this time, Ohio EPA is requesting U.S. EPA approval of these changes for incorporation into the SIP, to the extent requested in the cover letter for this submittal.

The transmittal letter for this documentation should meet the requirements in 40 CFR Part 51, Appendix V, Section 2.1(a): a "formal letter of submittal from the Governor or his designee, requesting EPA approval of the plan or revision."

The following documents are attached for your consideration per the requirements of 40 CFR Part 51, Appendix V:

Article One addresses the following two requirements:

40 CFR Part 51, Appendix V, Section 2.1(b)

Evidence that the State has adopted the plan in the State code or body of regulations; or issued the permit, order, consent agreement (hereafter "document") in final form. That evidence shall include the date of adoption or final issuance as well as the effective date of the plan, if different from the adoption/issuance date.

40 CFR Part 51, Appendix V, Section 2.1(d)

A copy of the actual regulation, or document submitted for approval and incorporation

by reference into the plan, including indication of the changes made to the existing approved plan, where applicable. The submittal shall be a copy of the official State regulation /document signed, stamped, and dated by the appropriate State official indicating that it is fully enforceable by the State. The effective date of the regulation/document shall, whenever possible, be indicated in the document itself.

Certified copies of the rules, in redline and strikeout, are being submitted for approval and incorporation by reference into the plan. The copies are included as evidence that the State has adopted the body of regulations in final form. This submittal includes copies of the official State regulations signed, stamped, and dated by the appropriate State official indicating that they are fully enforceable by the State. The effective date of each regulation is indicated in the document itself. Please consider that Ohio has an electronic rule filing system and all certifications/signatures of regulations are done electronically.

Article Two addresses the following requirement:

Copies of the public notice of adoption and Director's Findings & Orders have been included as evidence of the date of adoption as well as the effective date of the regulations and evidence that public notice was given of the proposed changes consistent with procedures approved by EPA, including the date of publication of such notice.

Requirements of 40 CFR Part 51, Appendix V, Section 2.1(c):

Evidence that the State has the necessary legal authority under State law to adopt and implement the plan.

Ohio's legislature has given Ohio EPA authority under paragraphs (A) and (E) of Section 3704.03 of the Ohio Revised Code (ORC) to enact these rules. Copies of these sections of the ORC can be provided upon request.

Article Three addresses the following requirements:

40 CFR Part 51, Appendix V, Section 2.1(e)

Evidence that the State followed all of the procedural requirements of the State's laws and constitution in conducting and completing the adoption/issuance of the plan.

40 CFR Part 51, Appendix V, Section 2.1(f)

Evidence that public notice was given of the proposed change consistent with procedures approved by EPA, including the date of publication of such notice.

Ohio EPA has included a narrative and several attachments as evidence that the State followed all of the procedural requirements of the State's laws and constitution in conducting and completing the adoption/issuance of the plan.

Article Four

40 CFR Part 51, Appendix V, Section 2.1(g)

Certification that public hearings(s) were held in accordance with the information provided in the public notice and the State's laws and constitution, if applicable.

A copy of the transcript from the public hearing has been provided as certification that a public hearing was held in accordance with the information provided in the public notice and the State's laws and constitution, if applicable.

Article Five

40 CFR Part 51, Appendix V, Section 2.1(h)

Compilation of public comments and the State's response thereto.

Copies of the Response to Comments documents for both the draft language and proposed language comment periods are attached.

Ohio EPA asks that the above mentioned rules be accepted as revisions and additions into Ohio's SIP, to the extent requested in the cover letter for this submittal.

Article I

Certified Copy of Rules

3745-21-01

Definitions and incorporation by reference.

[Comment: For dates and availability of non-regulatory government publications, publications of recognized organizations and associations, federal rules, and federal statutory provisions referenced in this rule, see paragraph (JJ) of this rule titled "referenced materials."]

(A) Except as otherwise provided in this rule, the definitions in rule 3745-15-01 of the Administrative Code ~~shall~~ apply to this chapter.

(B) As used in this chapter:

- (1) "AAMA" means the American architectural manufacturer association.
- (2) "ASTM" means the American society for testing and materials also known as ASTM international.
- (3) "Btu" means British thermal unit.
- (4) "Btu per hour-foot-degree-Fahrenheit" means British thermal unit per hour-foot-degree-Fahrenheit.
- (5) "CTG" means control technique guideline. A CTG is a USEPA guidance document that triggers a responsibility under Section 182(b)(2) of the Clean Air Act for states to submit reasonably available control technology (RACT) rules for stationary sources of VOC emissions as part of their state implementation plans. Each CTG contains a presumptive norm for RACT for a specific category, based on USEPA's evaluation of that category. The following rules promulgated by the Ohio EPA cover categories for which USEPA has issued a CTG:
 - (a) Paragraphs (C) to ~~(M), (O) to (R)~~, (T), (U), ~~(W)~~ to (Z), (BB) to (EE), ~~and (DDD) and (EEE)~~ of rule 3745-21-09 of the Administrative Code.
 - (b) Rules 3745-21-13, 3745-21-15, 3745-21-19, 3745-21-20, 3745-21-22, 3745-21-23, 3745-21-24, and 3745-21-26 to 3745-21-29 of the Administrative Code.
- (6) "DC" means direct current.
- (7) "Day" means a period of twenty-four consecutive hours beginning at twelve a.m., or beginning at a time consistent with a facility's operating schedule.
- (8) "Exempt solvent" means any of the compounds which are specifically identified as not being volatile organic compounds, as defined in this rule.

- (9) "Lb per mmBtu" or "lb/mmBtu" means pound per million British thermal units.
- (10) "Incinerator" means a combustion apparatus designed for high temperature operation in which solid, semisolid, liquid, or gaseous combustible wastes are ignited and burned.
- (11) "Non-CTG" means all other stationary sources of VOC emissions for which the USEPA has not developed a control technique guideline document.
- (12) "Ohio EPA" means Ohio environmental protection agency.
- (13) "Organic compound" means any chemical compound containing carbon excluding carbon monoxide, carbon dioxide, carbonic acid, metallic carbides, metallic carbonates, ammonium carbonate, methane (except methane from landfill gases), and ethane.
- (14) "Permit-to-install and operate" or "PTIO" means a permit-to-install and a permit-to-operate applicable to air contaminant sources not located at facilities subject to Chapter 3745-77 of the Administrative Code.
- (15) "Potential to emit" means the maximum capacity of a facility or stationary source to emit an organic compound or VOC under ~~its~~ physical and operational design. Any physical or operational limitation on the capacity of the facility or stationary source to emit an organic compound or VOC, including air pollution control equipment and restrictions on hours of operation or on the type or amount of material combusted, stored or processed, shall be treated as part of ~~its~~the design if the limitation or the effect it would have on emissions is federally enforceable ~~or legally and practicably enforceable by the state.~~
- (16) "USEPA" means United States environmental protection agency.
- (17) "Volatile organic compound" or "VOC" means any organic compound which participates in atmospheric photochemical reactions. (This includes any organic compound other than the compounds listed in the following table and any class of perfluorocarbon compounds that consists of (a) cyclic, branched, or linear, completely fluorinated alkanes, (b) cyclic, branched, or linear, completely fluorinated ethers with no unsaturations, (c) cyclic, branched, or linear, completely fluorinated tertiary amines with no unsaturations, or (d) sulfur-containing perfluorocarbons with no unsaturations and with sulfur bonds only to carbon and fluorine. These compounds have been determined to have negligible photochemical reactivity. For purposes of determining compliance with emission limits, VOC will be measured by the approved test methods. Where such a method also inadvertently measures compounds with negligible

photochemical reactivity, an owner or operator may exclude these negligibly reactive compounds when determining compliance with an emission standard.)

Table - Organic compounds that are not a VOC

methane	HFC 43-10mee (1,1,1,2,3,4,4,5,5,5-decafluoropentane)
ethane	HFC-32 (difluoromethane)
methyl chloroform (1,1,1-trichloroethane)	HFC-161 (ethylefluoride)
CFC-113 (1,1,2-trichloro-1,2,2-trifluoroethane)	HFC-236fa (1,1,1,3,3,3-hexafluoropropane)
methylene chloride	HFC-245ca (1,1,2,2,3-pentafluoropropane)
CFC-11 (trichlorofluoromethane)	HFC-245ea (1,1,2,3,3-pentafluoropropane)
CFC-12 (dichlorodifluoromethane)	HFC-245eb (1,1,1,2,3-pentafluoropropane)
HCFC-22 (chlorodifluoromethane)	HFC-245fa (1,1,1,3,3-pentafluoropropane)
HFC-23 (trifluoromethane)	HFC-236ea (1,1,1,2,3,3-hexafluoropropane)
CFC-114 (1,2-dichloro-1,1,2,2-tetrafluoroethane)	HFC-365mfc (1,1,1,3,3-pentafluorobutane)
CFC-115 (chloropentafluoroethane)	HCFC-31 (chlorofluoromethane)
HCFC-123 (1,1,1-trifluoro-2,2-dichloroethane)	HCFC-151a (1-chloro-1-fluoroethane)
HFC-134a (1,1,1,2-tetrafluoroethane)	HCFC-123a (1,2-dichloro-1,1,2-trifluoroethane)
HCFC-141b (1,1-dichloro-1-fluoroethane)	C ₄ F ₉ OCH ₃ or HFE-7100 (1,1,1,2,2,3,3,4,4-nonafluoro-4-methoxy-butane)
HCFC-142b (1-chloro-1,1-difluoroethane)	(CF ₃) ₂ CF ₂ OCH ₃ (2-(difluoromethoxy methyl) -1,1,1,2,3,3,3-heptafluoropropane)
HCFC-124 (2-chloro-1,1,1,2-tetrafluoroethane)	C ₄ F ₉ OC ₂ H ₅ or HFE-7200 (1-ethoxy-1,1,2,2,3,3,4,4,4-nonafluorobutane)

HFC-125 (pentafluoroethane)	$(CF_3)_2CFCF_2OC_2H_5$ (2-(ethoxydifluoro methyl) -1,1,1,2,3,3,3- heptafluoropropane)
HFC-134 (1,1,2,2-tetrafluoroethane)	methyl acetate
HFC-143a (1,1,1-trifluoroethane)	$n-C_3F_7OCH_3$ or HFE-7000 (1,1,1,2,2,3,3-heptafluoro-3-methoxy-propane)
HFC-152a (1,1-difluoroethane)	HFE-7500 (3-ethoxy-1,1,1,2,3,4,4,5,5,6,6,6-dodecafluoro-2-(trifluoromethyl) hexane)
PCBTF (parachlorobenzotrifluoride)	HFC 227ea (1,1,1,2,3,3,3-heptafluoropropane)
cyclic, branched, or linear completely methylated siloxanes	methyl formate
acetone	t-butyl acetate
perchloroethylene (tetrachloroethylene)	dimethyl carbonate
HCFC-225ca (3,3-dichloro- 1,1,1,2,2-pentafluoropropane)	propylene carbonate
HCFC-225cb (1,3-dichloro- 1,1,2,2,3-pentafluoropropane)	any organic compound listed in 40 CFR 51.100(s)(1) or (s)(5)

(C) As used in rule 3745-21-07 of the Administrative Code (pertaining to the control of emissions of organic materials from stationary sources):

- (1) [Reserved.]
- (2) "Effluent water separator" means any tank, box, sump, or other container in which any volatile photochemically reactive material floating on or entrained or contained in water entering such tank, box, sump, or other container is physically separated and removed from such water prior to outfall, drainage, or recovery of such water.
- (3) "Liquid organic material" means any organic material which is a liquid at standard conditions.
- (4) "Organic material" means any chemical compound containing carbon, excluding carbon monoxide, carbon dioxide, carbonic acid, metallic carbides, metallic carbonates, and ammonium carbonate.

(5) "Photochemically reactive material" means any liquid organic material with an aggregate of more than twenty per cent of its total volume composed of the chemical compounds classified below or which exceed any of the following individual percentage composition limitations, referred to the total volume of liquid:

- (a) A combination of hydrocarbons, alcohols, aldehydes, esters, ethers or ketones having an olefinic or cyclo-olefinic type of unsaturation except perchloroethylene: five per cent.
- (b) A combination of aromatic hydrocarbons with eight or more carbon atoms to the molecule except ethylbenzene: eight per cent.
- (c) A combination of ethylbenzene, ketones having branched hydrocarbon structures, trichloroethylene or toluene: twenty per cent.

~~Whenever any~~Any organic material or any constituent of an organic material that may be classified from its chemical structure into more than one of the above groups of organic compounds, ~~it shall be~~ is considered as a member of the most reactive chemical group, that is, that group having the least allowable per cent of the total volume of liquid.

(6) "Submerged fill pipe" means any fill pipe with the discharge opening entirely submerged when the liquid level is six inches above the bottom of the tank; or when applied to a tank which is loaded from the side, ~~shall mean~~ means any fill pipe with the discharge opening entirely submerged when the liquid level is eighteen inches above the bottom of the tank.

(7) "Volatile photochemically reactive material" means any photochemically reactive material which has a vapor pressure of 1.5 pounds per square inch absolute or greater under actual storage conditions.

(D) As used in paragraphs (B) to (K), (S), (U), (Y), (FF), (HH), (II), and (PP) of rule 3745-21-09 of the Administrative Code (pertaining to coating lines and printing lines) and in rules 3745-21-04, 3745-21-10, 3745-21-18, 3745-21-26, and 3745-21-29 of the Administrative Code:

(1) "Adhesion primer" means the following:

- (a) For the purpose of paragraph (HH) of rule 3745-21-09 of the Administrative Code, a coating used to promote adhesion of a topcoat on surfaces such as trim moldings, door locks and door sills, where sanding is impractical.

- (b) For the purpose of rule 3745-21-26 of the Administrative Code, a coating that is applied to a polyolefin part to promote the adhesion of a subsequent coating. An adhesion primer is clearly identified as an adhesion primer or adhesion promoter on its accompanying material safety data sheet.
- (2) "Adhesive" means any chemical substance that is applied for the purpose of bonding two surfaces together other than by mechanical means.
- (3) "Air dried coating" means a coating that is dried by the use of air or forced warm air at temperatures up to one hundred ninety-four degrees Fahrenheit.
- (4) "Airless spray" means a spray coating method in which the coating is atomized by ~~forcing it~~being forced through a small nozzle opening at high pressure. The coating is not mixed with air before exiting from the nozzle opening.
- (5) "Anti-chip coating" means a coating designed to reduce stone chipping damage. Anti-chip coatings may be applied to broad areas of the vehicle or to selected vehicle surfaces that are most vulnerable to impingement by stones and other road debris (e.g., rocker panels, the bottom edges of doors and fenders, and the leading edge of the roof). Anti-chip coatings are typically applied after the electrodeposition primer and before the topcoat and are considered primer-surfacer coatings.
- (6) "Antifoulant coating" means any coating that is applied to the underwater portion of a boat specifically to prevent or reduce the attachment of biological organisms and that is registered with USEPA as a pesticide under the Federal Insecticide, Fungicide, and Rodenticide Act contained in 7 USC 136 to 136y.
- (7) "Antique motor vehicle" means a motor vehicle, but not a reproduction thereof, manufactured more than twenty five years prior to the current year which has been maintained in or restored to a condition which is substantially in conformance with manufacturer specifications.
- (8) "Aqueous coating" means a water-based surface coating applied directly over ink on a printed substrate for the purpose of enhancing or protecting the printed surface.
- (9) "As applied" means the formulation of a coating during the application on or impregnation into a substrate, including any dilution solvents or thinners added at the source before application of the coating.
- (10) "Automobile" means a passenger car or passenger car derivative capable of seating not more than twelve passengers.

- (11) "Automobile and light-duty truck adhesive" means an adhesive, including glass bonding adhesive, used at an automobile or light-duty truck assembly coating facility, applied for the purpose of bonding two vehicle surfaces together without regard to the substrates involved.
- (12) "Automobile or light-duty truck assembly plant" means a facility where automobile or light-duty truck bodies, frames and associated parts, are assembled for eventual inclusion into a finished product ready for sale to vehicle dealers. Customizers, body shops and other repainters are excluded from this definition.
- (13) "Automobile and light-duty truck bedliner" means a multi-component coating, used at an automobile or light-duty truck assembly coating facility, applied to a cargo bed after the application of topcoat and outside of the topcoat operation to provide additional durability and chip resistance.
- (14) "Automobile and light-duty truck cavity wax" means a coating, used at an automobile or light-duty truck assembly coating facility, applied into the cavities of the vehicle primarily for the purpose of enhancing corrosion protection.
- (15) "Automobile and light-duty truck deadener" means a coating, used at an automobile or light-duty truck assembly coating facility, applied to selected vehicle surfaces primarily for the purpose of reducing the sound of road noise in the passenger compartment.
- (16) "Automobile and light-duty truck gasket/gasket sealing material" means a fluid, used at an automobile or light-duty truck assembly coating facility, applied to coat a gasket or replace and perform the same function as a gasket. Automobile and light-duty truck gasket/gasket sealing material includes room temperature vulcanization (RTV) seal material.
- (17) "Automobile and light-duty truck glass bonding primer" means a primer, used at an automobile or light-duty truck assembly coating facility, applied to windshield or other glass, or to body openings, to prepare the glass or body opening for the application of glass bonding adhesives or the installation of adhesive bonded glass. Automobile and light-duty truck glass bonding primer includes glass bonding/cleaning primers that perform both functions (cleaning and priming of the windshield or other glass, or body openings) prior to the application of adhesive or the installation of adhesive bonded glass.

- (18) "Automobile and light-duty truck lubricating wax/compound" means a protective lubricating material, used at an automobile or light-duty truck assembly coating facility, applied to vehicle hubs and hinges.
- (19) "Automobile and light-duty truck sealer" means a high viscosity material, used at an automobile or light-duty truck assembly coating facility, generally, but not always, applied in the paint shop after the body has received an electrodeposition primer coating and before the application of subsequent coatings (e.g., primer-surfacer). The primary purpose of automobile and light-duty truck sealer is to fill body joints completely so that there is no intrusion of water, gases or corrosive materials into the passenger area of the body compartment. Such materials are also referred to as sealant, sealant primer, or caulk.
- (20) "Automobile and light-duty truck trunk interior coating" means a coating, used at an automobile or light-duty truck assembly coating facility outside of the primer-surfacer and topcoat operations, applied to the trunk interior to provide chip protection.
- (21) "Automobile and light-duty truck underbody coating" means a coating, used at an automobile or light-duty truck assembly coating facility, applied to the undercarriage or firewall to prevent corrosion or provide chip protection.
- (22) "Automobile and light-duty truck weatherstrip adhesive" means an adhesive, used at an automobile or light-duty truck assembly coating facility, applied to weatherstripping materials for the purpose of bonding the weatherstrip material to the surface of the vehicle.
- (23) "Automotive elastomeric coating" means a coating designed for application over surfaces of flexible mobile equipment and mobile equipment components, such as elastomeric bumpers.
- (24) "Automotive impact-resistant coating" means a coating designed to resist chipping caused by road debris.
- (25) "Automotive jambing clearcoat" means a fast-drying, ready-to-spray clearcoat applied to surfaces such as door jambs and trunk and hood edges to allow for quick closure.
- (26) "Automotive lacquer" means a thermoplastic coating applied directly to bare metal surfaces of mobile equipment and mobile equipment components which dries primarily by solvent evaporation, and which is resoluble in its original solvent.

- (27) "Automotive low-gloss coating" means a coating which exhibits a gloss reading less than or equal to twenty-five on a sixty-degree-glossmeter.
- (28) "Automotive multi-colored topcoat" means a topcoat that exhibits more than one color, is packaged in a single container, and camouflages surface defects on areas of heavy use, such as cargo beds and other surfaces of trucks and other utility vehicles.
- (29) "Automotive pretreatment" means a primer that contains a minimum of 0.5 per cent acid, by weight, that is applied directly to bare metal surfaces of mobile equipment and mobile equipment components to provide corrosion resistance and to promote adhesion of subsequent coatings.
- (30) "Automotive primer-sealer" means a coating applied to mobile equipment and mobile equipment components prior to the application of a topcoat for the purpose of providing corrosion resistance, promoting adhesion of subsequent coatings, promoting color uniformity, and promoting the ability of the undercoat to resist penetration by the topcoat.
- (31) "Automotive primer-surfacer" means a coating applied to mobile equipment and mobile equipment components prior to the application of topcoat for the purpose of filling surface imperfections in the substrate; providing corrosion resistance; or promoting adhesion of subsequent coatings.
- (32) "Automotive specialty coating" means coatings including, but not limited to, elastomeric coatings, adhesion promoters, low gloss coatings, bright metal trim repair coatings, jambing clearcoats, impact resistant coatings, rubberized asphaltic underbody coatings, uniform finish blenders, weld-through primers applied to automotive surfaces and lacquer topcoats applied to a classic motor vehicle or to an antique motor vehicle.
- (33) "Automotive topcoat" means a coating or series of coatings applied over an automotive primer-surfacer, automotive primer-sealer or existing finish on the surface of mobile equipment and mobile equipment components for the purpose of protection or beautification.
- (34) "Automotive touch up repair" means the application of automotive topcoat finish materials to cover minor finishing imperfections equal to or less than one inch in diameter.
- (35) "Automotive/transportation plastic parts" means the interior and exterior plastic components of automobiles, trucks, tractors, lawnmowers, and other like mobile equipment intended for primary use on land, with the exception of the

following: plastic parts coated on the main (body) paint line in automobile and light duty truck assembly plants and truck assembly plants, and plastic parts coated during the refinishing or final repair of automobiles, trucks, tractors, lawnmowers and other like mobile equipment.

- (36) "Baked coating" means a coating that is cured at a temperature at or above one hundred ninety-four degrees Fahrenheit.
- (37) "Basecoat" means, for can coating lines, the exterior base coating of a two-piece can or the exterior and interior base coating of a three-piece can or three-piece can end; and basecoat means, for automotive/transportation plastic parts coating lines, the highly pigmented, often metallic first coating in a two-step topcoat system which is followed by a clearcoat, resulting in a finish with high-gloss characteristics.
- (38) "Basecoat/clearcoat system" means a topcoat system applied to exterior and selected interior vehicle surfaces primarily to provide an aesthetically pleasing appearance and acceptable durability performance. It consists of a layer of pigmented basecoat color coating, followed directly by a layer of a clear or semitransparent coating. It may include multiple layers of color coats or tinted clear materials.
- (39) "Black automotive coating" means a coating which meets both of the following criteria:
- (a) Maximum lightness: twenty-three units.
 - (b) Saturation: less than 2.8, where saturation equals the square root of $A^2 + B^2$.
- These criteria are based on Cielab color space, 0/45 geometry. For spherical geometry, specular included, maximum lightness is thirty-three units.
- (40) "Body part" means exterior parts of motor vehicles such as hoods, fenders, doors, roof, quarter panels, decklids, tail gates, and cargo beds. Body parts were traditionally made of sheet metal, but now are also made of plastic. Bumpers, fascia, and cladding are not body parts.
- (41) "Business machine" means a device that uses electronic or mechanical methods to process information, perform calculations, print or copy information or convert sound into electrical impulses for transmission, including devices listed in standard industrial classification numbers 3572, 3573, 3574, 3579, and 3661 and photocopy machines, a subcategory of standard industrial classification number 3861.

- (42) "Business machine plastic parts" means the plastic housings and other exterior plastic components of electronic office equipment and musical equipment, including, but not limited to the following: computers, monitors, printers and keyboards, facsimile machines, copiers, microfiche readers, cellular and standard phones, and pencil sharpeners. This definition excludes internal electrical components of business machines.
- (43) "Camouflage coating" means a coating, used principally by the military, to conceal equipment from detection.
- (44) "Can" means a single walled metal container constructed wholly of tin plate, terne plate, black plate (including tin-free steel), waste plate, aluminum sheet, or impact extrusions designed for packaging products. It excludes "steel pails" defined as single walled shipping containers having capacities of one gallon or greater and which are cylindrically constructed of steel of twenty-nine-gauge or heavier.
- (45) "Capture system" means all equipment, including but not limited to hoods, ducts, fans, ovens and dryers, used to contain, collect, and route VOC vapors released from a coating line or printing line.
- (46) "Classic motor vehicle" means a motor vehicle, but not a reproduction thereof, manufactured at least fifteen years prior to the current year which has been maintained in or restored to a condition which is substantially in conformity with manufacturer specifications and appearance.
- (47) "Cleaning material" means a solvent used to remove contaminants and other materials such as dirt, grease, oil, and dried (e.g., depainting) or wet coating from a substrate before or after coating application; or from equipment associated with a coating operation, such as spray booths, spray guns, tanks, and hangers. Thus, it includes any cleaning material used on substrates or equipment or both.
- (48) "Clearcoat" means a transparent coating usually applied over a colored, opaque coat to improve gloss and provide protection to the colorcoat below.
- (49) "Clear coating" means a ~~colorless~~ coating which contains binders and may contain dissolved dyes, but no pigment, and is formulated to form a transparent film.
- (50) "Coating or surface coating" means a material applied onto or saturated within a substrate for decorative, protective or functional purposes. Such materials include, but are not limited to, paints, varnishes, sealers, adhesives and inks.

- (51) "Coating applicator" means an apparatus used to apply a surface coating.
- (52) "Coating line" means an operation consisting of a series of one or more coating applicators and any associated flash-off areas, drying areas and ovens wherein a surface coating is applied, dried, or cured. The coating line does not have to include an oven, or flash-off area, or drying area in order to be included within this definition.
- (53) "Coating of plastic parts of automobiles and trucks" means the coating of any plastic part that is or ~~shall~~ will be assembled with other parts to form an automobile or truck.
- (54) "Coating of plastic parts of business machines" means the coating of any plastic part that is or ~~shall~~ will be assembled with other parts to form a business machine.
- (55) "Coil" means a flat metal sheet or strip that is packaged in a roll and that has a thickness of 0.006 inch or more.
- (56) "Commercial motor vehicle and mobile equipment refinishing operation" means any company or individual, other than the original manufacturer, that applies a coating containing a VOC as a pretreatment, primer, sealant, basecoat, clear coat, or topcoat to mobile equipment for commercial purposes.
- (57) "Continuously monitor" means to measure data values of a parameter at least once every fifteen minutes and to record either each measured data value or block average values for a fifteen-minute or shorter time period. A block average value is the average of all measured data values during the time period; or if data values are measured more frequently than once per minute, the average of measured data values taken at least once per minute during the time period.
- (58) "Control system" means any device or combination of devices designed to recover or incinerate VOC vapors received from a capture system.
- (59) "Dip coating" means a method of applying coatings to a substrate by submersion into and removal from a coating bath.
- (60) "Drum" means any cylindrical metal shipping container larger than twelve gallons but no larger than one hundred ten gallons in capacity.
- (61) "Electrostatic application" means a method of applying coating particles or coating droplets to a grounded substrate by electrically charging them.

- (62) "Electric-dissipating coating" means a coating that rapidly dissipates a high-voltage electric charge.
- (63) "Electric-insulating and thermal-conducting coating" means a coating that displays an electrical insulation of at least one thousand volts DC per mil on a flat test plate and an average thermal conductivity of at least 0.27 Btu per hour-foot-degree-Fahrenheit.
- (64) "Electric-insulating varnish" or "electric-insulating coating" means a non-convertible-type coating applied to electric motors, components of electric motors, or power transformers, to provide electrical, mechanical, and environmental protection or resistance.
- (65) "Electrodeposition" or "EDP" means the application of a surface coating to an object by immersing the object into a water bath containing the surface coating material and inducing an electric potential between the object and the bath.
- (66) "Electrodeposition primer" or "EDP primer" means a process of applying a protective, corrosion-resistant waterborne primer on exterior and interior surfaces that provides thorough coverage of recessed areas. It is a dip coating method that uses an electrical field to apply or deposit the conductive coating onto the part. The object being painted acts as an electrode that is oppositely charged from the particles of paint in the dip tank. Also referred to as E-coat, Uni- Prime, and ELPO primer.
- (67) "Electromagnetic interference/radio frequency interference shielding coating" or "EMI/RFI shielding coating" means a coating used on electrical or electronic equipment to provide shielding against electromagnetic interference, radio frequency interference, or static discharge.
- (68) "Electrostatic preparation coating" means a coating that is applied to a plastic part solely to provide conductivity for the subsequent application of a prime, a topcoat, or other coating through the use of electrostatic application methods. An electrostatic prep coat is clearly identified as an electrostatic prep coat on its accompanying material safety data sheet.
- (69) "Enamel" means a type of surface coating in which drying occurs by evaporation of the solvent and polymerization of the pigmented drying oils.
- (70) "End sealing compound" means a synthetic rubber or plastic compound which is applied onto can ends and which functions as a gasket when the end is assembled on the can.

- (71) "Etching filler coating" means coating that contains less than twenty-three per cent solids by weight and at least one-half per cent acid by weight, and is used instead of applying a pretreatment coating followed by a primer.
- (72) "Excluding water" means subtracting the volume of water and other volatile materials which are not VOC.
- (73) "Exterior base coating" means a coating applied to the exterior of a can to provide exterior protection to the metal or to provide background for the lithographic or printing operation.
- (74) "Exterior bottom end" means the outside surface of the bottom side of a two-piece can.
- (75) "Extreme high-gloss coating" means the following:
- (a) For the surface coating of metal furniture, a coating which, when tested by ASTM ~~D523-08~~D523, shows a reflectance of seventy-five or more on a sixty degree meter.
 - (b) For the surface coating of miscellaneous metal or plastic parts, a coating which, when tested by ASTM ~~D523-08~~D523, shows a reflectance of ninety or more on a sixty degree meter.
- (76) "Extreme performance coating" means the following:
- (a) For the surface coating of metal furniture, a coating designed for exposure to any of the following: year-round outdoor weather, temperatures consistently above two hundred three degrees Fahrenheit, detergents, scouring, solvents, corrosive materials, corrosive atmospheres or similar harsh conditions.
 - (b) For the surface coating of miscellaneous metal or plastic parts, a coating used on a metal or plastic surface where the coated surface is, in its intended use, subject to any of the following:
 - (i) Chronic exposure to corrosive, caustic or acidic agents, chemicals, chemical fumes, chemical mixtures or solutions.
 - (ii) Repeated exposure to temperatures in excess of two hundred and fifty degrees Fahrenheit.

- (iii) Repeated heavy abrasion, including mechanical wear and repeated scrubbing with industrial grade solvents, cleansers or scouring agents.

Extreme performance coatings include, but are not limited to, coatings applied to locomotives, railroad cars, farm machinery, and heavy duty trucks.

- (77) "Extrusion coater" means an apparatus in which a coating material is applied by means of a slotted die to a moving substrate, which is fed from an unwinding roll.
- (78) "Fabric coating" means a coating applied to a textile substrate by dipping or by means of a knife or roll coater.
- (79) "Final repair" means the operations performed and coatings applied to completely-assembled motor vehicles or to parts that are not yet on a completely assembled vehicle to correct damage or imperfections in the coating. The curing of the coatings applied in these operations is accomplished at a lower temperature than that used for curing primer-surfacer and topcoat. This lower temperature cure avoids the need to send parts that are not yet on a completely assembled vehicle through the same type of curing process used for primer-surfacer and topcoat and is necessary to protect heat sensitive components on completely assembled vehicles.
- (80) "Finish primer/surfacer coating" means a coating applied with a wet film thickness of less than ten mils prior to the application of a topcoat for purposes of providing corrosion resistance, adhesion of subsequent coatings, a moisture barrier, or promotion of a uniform surface necessary for filling in surface imperfections.
- (81) "Flashoff area" means the area of a facility through which coated materials travel from the coating applicator to the oven.
- (82) "Flexible coating" means any coating with the ability to withstand dimensional changes that is required to comply with engineering specifications for impact resistance, mandrel bend, or elongation as defined by the original equipment manufacturer.
- (83) "Flexographic packaging printing line" means a means a flexographic printing line in which surface coatings are applied to paper, paperboard, metal foil, plastic film, or other substrates which are subsequently formed into packaging products or labels for articles.

- (84) "Flexographic printing line" means a printing line in which each roll printer uses a roll with raised areas for applying an image to the substrate. The image carrier on the roll is made of rubber or other flexible elastomeric material.
- (85) "Flow coat" means a non-atomized technique of applying coatings to a substrate with a fluid nozzle in a fan pattern with no air supplied to the nozzle.
- (86) "Fog coating" means a coating is applied to a plastic part for the purpose of color matching without masking a molded-in texture. ~~A fog coat shall not be~~ and that is not applied at a thickness of more than 0.5 mils of coating solids.
- (87) "Food can ends" means can ends used for cans that store food products other than soft drinks or alcoholic beverages.
- (88) "Fountain solution" means a surface coating applied to the plate roll of an offset lithographic printing line for the purpose of wetting only the nonimage areas so that they are not ink receptive.
- (89) "Glossreducer" means the following:
- (a) For miscellaneous metal and plastic parts; glossreducer means a low gloss coating formulated to eliminate glare for safety purposes on interior surfaces of a vehicle, as specified under United States department of transportation motor vehicle safety standards.
 - (b) For miscellaneous industrial adhesives and sealants; glossreducer means a coating that is applied at a thickness of no more than 0.5 mils of coating solids to a plastic part solely to reduce the shine of the part ~~and such gloss reducer shall not be applied at a thickness of more than 0.5 mils of coating solids.~~
- (90) "Guidecoat" means a surface coating applied to the body of an automobile or light-duty truck between the electrodeposition prime coat and the topcoat.
- (91) "Hand application methods" means the application of coatings by manually held non-mechanically operated equipment. Such equipment includes paintbrushes, hand rollers, caulking guns, trowels, spatulas, syringe daubers, rags, and sponges.
- (92) "Heat-resistant coating" means a coating that must withstand a temperature of at least four hundred degrees Fahrenheit during normal use.

- (93) "Heavier vehicle" means a self-propelled vehicle designed for transporting persons or property on a street or highway that has a gross vehicle weight rating over eighty-five hundred pounds.
- (94) "Heavier vehicle assembly facility" means a facility where heavier vehicle bodies, frames and associated parts, are assembled for eventual inclusion into a finished product ready for sale to vehicle dealers. Customizers, body shops and other repainters are excluded from this definition.
- (95) "High-bake coating" means a coating designed to cure at temperatures above one hundred ninety-four degrees Fahrenheit.
- (96) "High-build primer/surfacer coating" means a coating applied with a wet film thickness of ten mils or more prior to the application of a topcoat for purposes of providing corrosion resistance, adhesion of subsequent coatings, or a moisture barrier, or promoting a uniform surface necessary for filling in surface imperfections.
- (97) "High-gloss coating" means any coating which shows a reflectance of eighty-five on a sixty degree meter when tested by ASTM ~~D523-08~~D523.
- (98) "High-performance architectural coating" means a coating used to protect architectural subsections and meets AAMA ~~2604-13~~2604 "Voluntary specification, performance requirements and test procedures for high performance organic coatings on aluminum extrusions and panels" or AAMA ~~2605-13~~2605 "Voluntary specification, performance requirements and test procedures for superior performing organic coatings on aluminum extrusions and panels."
- (99) "High-performance architectural aluminum coating" means a coating that is applied to aluminum used in architectural subsections and meets AAMA ~~2605-13~~2605, "Voluntary specification, performance requirements and test procedures for superior performing organic coatings on aluminum extrusions and panels."
- (100) "High-temperature coating" means a coating that is certified to with stand a temperature of one thousand degrees Fahrenheit for twenty-four hours.
- (101) "High volume, low pressure sprayer" or "HVLP sprayer" means an air atomized sprayer that operates at a maximum air pressure of ten pounds per square inch gauge (psig) as measured at the nozzle.
- (102) "Ink" means a coating applied by a roll printer.

- (103) "In-line repair" means the operation performed and coating applied to correct damage or imperfections in the topcoat on parts that are not yet on a completely assembled vehicle. The curing of the coatings applied in these operations is accomplished at essentially the same temperature as that used for curing the previously applied topcoat. Also referred to as high bake repair or high bake reprocess. In-line repair is considered part of the topcoat operation.
- (104) "Interior base coating" means a coating applied to the interior of a can.
- (105) "Interior body coating" means a coating applied subsequent to the application of an interior base coating to the interior of a can body.
- (106) "Knife coater" means an apparatus in which a coating material is applied to a moving substrate, which is fed from an unwinding roll, by drawing the substrate beneath a knife (blade) that is designed to spread the coating evenly over the width of the substrate.
- (107) "Lacquer" means a type of surface coating in which drying occurs by evaporation of the solvent and deposition of the resin and any pigment.
- (108) "Large appliance" means door, case, lid, panel, interior part, or interior support part of a residential or commercial washer, dryer, range, refrigerator, freezer, water heater, dishwasher, trash compactor, air conditioner, ovens, microwave ovens, or other similar product.
- (109) "Light-duty truck" means a motor vehicle rated at eight thousand five hundred pounds gross weight or less which is designed primarily for highway use and for the transportation of property, or is a derivative of such vehicle.
- (110) "Line" means the same as "coating line."
- (111) "Lithographic printing line" means a printing line, except that the substrate is not necessarily fed from an unwinding roll, in which each roll printer uses a roll where both the image and nonimage areas are essentially in the same plane (planographic).
- (112) "Low-bake coatings" means coatings designed to cure at temperatures below one hundred ninety-four degrees Fahrenheit.
- (113) "Magnet wire coating" means a coating of electrically insulating varnish or enamel which is applied to aluminum or copper wire prior to ~~its~~ formation into an electromagnetic coil.

- (114) "Magnetic data storage disk coating" mean a coating used on a metal disk which stores data magnetically.
- (115) "Mask coating" means a thin film coating applied through a template to coat a small portion of a substrate.
- (116) "Metal furniture" means any metal part of household, business, institutional or office furniture, excluding hardware. Such furniture includes, but is not limited to, cabinets, cases, desks, chairs, tables, partitions, shelving, lockers, storage racks, indoor waste receptacles and fixtures.
- (117) "Metallic coating" means a coating which contains more than five grams of metal particles per liter of coating, as applied. Metal particles are pieces of a pure elemental metal or a combination of elemental metals.
- (118) "Military specification coating" means a coating which has a formulation approved by a United States military agency for use on military equipment.
- (119) "Miscellaneous metal part or product" means any metal part or metal product except the following: cans, coils, metal furniture, large appliances, and aluminum or copper wire prior to ~~its~~ formation into an electromagnetic coil.
- (120) "Mobile equipment" means any equipment that may be drawn or is capable of being driven on a roadway, including, but not limited to, automobiles, trucks, truck bodies, truck trailers, cargo vaults, utility bodies, camper shells, construction equipment, farming equipment, and motorcycles.
- (121) "Mold-seal coating" means the initial coating applied to a new mold or repaired mold to provide a smooth surface which, when coated with a mold release coating, prevents products from sticking to the mold.
- (122) "Motor vehicle bedliner" means a multi-component coating, used at a facility that is not an automobile or light-duty truck assembly coating facility, applied to a cargo bed after the application of topcoat to provide additional durability and chip resistance.
- (123) "Motor vehicle cavity wax" means a coating, used at a facility that is not an automobile or light-duty truck assembly coating facility, applied into the cavities of the vehicle primarily for the purpose of enhancing corrosion protection.
- (124) "Motor vehicle deadener" means a coating, used at a facility that is not an automobile or light-duty truck assembly coating facility, applied to selected

vehicle surfaces primarily for the purpose of reducing the sound of road noise in the passenger compartment.

- (125) "Motor vehicle gasket/gasket sealing material" means a fluid, used at a facility that is not an automobile or light-duty truck assembly coating facility, applied to coat a gasket or replace and perform the same function as a gasket. Automobile and light-duty truck gasket/gasket sealing material includes room temperature vulcanization (RTV) seal material.
- (126) "Motor vehicle lubricating wax/compound" means a protective lubricating material, used at a facility that is not an automobile or light-duty truck assembly coating facility, applied to vehicle hubs and hinges.
- (127) "Motor vehicle sealer" means a high viscosity material, used at a facility that is not an automobile or light-duty truck assembly coating facility, generally, but not always, applied in the paint shop after the body has received an electrodeposition primer coating and before the application of subsequent coatings (e.g., primer-surfacer). The primary purpose of automobile and light-duty truck sealer is to fill body joints completely so that there is no intrusion of water, gases or corrosive materials into the passenger area of the body compartment. Such materials are also referred to as sealant, sealant primer, or caulk.
- (128) "Motor vehicle trunk interior coating" means a coating, used at a facility that is not an automobile or light-duty truck assembly coating facility, applied to the trunk interior to provide chip protection.
- (129) "Motor vehicle underbody coating" means a coating, used at a facility that is not an automobile or light-duty truck assembly coating facility, applied to the undercarriage or firewall to prevent corrosion or provide chip protection.
- (130) "Multi-colored coating" means a coating which exhibits more than one color when applied, and which is packaged in a single container and applied in a single coat.
- (131) "Multi-component coating" means a coating requiring the addition of a separate reactive resin, commonly known as a catalyst or hardener, before application to form an acceptable dry film.
- (132) "Non-flexible coating" means any coating without the ability to withstand dimensional changes that is not required to comply with engineering specifications for impact resistance, mandrel bend, or elongation as defined by the original equipment manufacturer.

- (133) "Offset lithographic printing line" means a lithographic printing line where the image is applied from a plate roll to an intermediate (blanket) roll and then transferred onto the substrate.
- (134) "One-component coating" means a coating that is ready for application as ~~it~~the coating comes out of ~~its~~the container to form an acceptable dry film. A thinner, necessary to reduce the viscosity, is not considered a component.
- (135) "Optical coating" means a coating applied to an optical lens.
- (136) "Oven" means a chamber within which heat is used for one or more of the following purposes: dry, bake, cure or polymerize a surface coating or ink.
- (137) "Overvarnish" means a surface coating applied directly over ink on the exterior of a can.
- (138) "Packaging rotogravure printing line" means a rotogravure printing line in which surface coatings are applied to paper, paperboard, metal foil, plastic film, or other substrates which are subsequently formed into packaging products or labels for articles.
- (139) "Pan backing coating" means a coating applied to the surface of pots, pans, or other cooking implements that are exposed directly to a flame or other heating elements.
- (140) "Paper coating" means a coating applied by dipping or by means of a knife, roll or extrusion coater to paper, paperboard, pressure sensitive tapes or labels, plastic film, or metal foil. Excluded from this definition are coatings used in substrate formation within a papermaking system and coatings applied within a printing line which is in compliance with the emission requirements contained in paragraph (Y) of rule 3745-21-09 of the Administrative Code.
- (141) "Papermaking system" means all equipment used to convert pulp into paper, paperboard or market pulp, including the stock storage and preparation systems, the paper or paperboard machines, and the paper machine white water system, broke recovery systems, and the systems involved in calendering, drying, on-machine coating, slitting, winding and cutting.
- (142) "Paper treater" means a coating line in which a uniform layer of phenolic or melamine resin is applied by dipping a continuously moving paper substrate into the resin and then using rollers to squeeze the excess resin from the paper.
- (143) "Plastic or composites molding facility" means a facility where the purchase cost of capital equipment used for plastic or composites molding, including

presses, tooling, and associated material processing and handling equipment, is greater than the purchase cost of capital equipment used for the surface coating of new automobile, new light-duty truck, or new heavier vehicle bodies or body parts for new automobiles, new light-duty trucks, or new heavier vehicles.

- (144) "Plastic part" means a product, or piece of a product, made from a substance that has been formed from resin through the application of pressure or heat ~~or both~~.
- (145) "Pleasure craft" means vessels which are manufactured or operated primarily for recreational purposes, or leased, rented, or chartered to a person or business for recreational purposes. ~~The and certified by the~~ owner or operator of such vessels ~~shall be responsible for certifying vessel~~ that the intended use is for recreational purposes.
- (146) "Pleasure craft surface coating" means any marine coating, except unsaturated polyester resin (fiberglass) coatings, applied by brush, spray, roller, or other means to a pleasure craft.
- (147) "Prefabricated architectural component coating" means a coating applied to metal parts and products which are to be used as an architectural structure.
- (148) "Pretreatment coating" means a coating which contains no more than twelve per cent solids by weight, and at least one-half per cent acid, by weight, is used to provide surface etching, and is applied directly to metal surfaces to provide corrosion resistance, adhesion, and ease of stripping.
- (149) "Pretreatment wash primer coating" means a coating which ~~contains no more than twelve per cent solids, by weight, and at least one-half per cent acids, by weight; is used to provide surface etching; and is applied directly to fiberglass and metal surfaces to provide corrosion resistance and adhesion of subsequent coatings; meets the following:~~
- (a) No more than twelve per cent solids, by weight, and at least one-half per cent acids, by weight.
 - (b) Is used to provide surface etching.
 - (c) Is applied directly to fiberglass and metal surfaces to provide corrosion resistance and adhesion of subsequent coatings.
- (150) "Primary coating" means electrodeposition primer, primer-surfacer (including anti-chip coatings), topcoat (basecoat and clearcoat) and final repair.

- (151) "Prime coat" means a surface coating which is used to aid the adhesion of a topcoat to a surface or prevent corrosion of the metal being coated. For the purpose of emission limitations, guidecoat and surfacer are included in the definition of prime coat.
- (152) "Primer" means any coating formulated and applied to a substrate to provide a firm bond between the substrate and subsequent coats.
- (153) "Primer-surfacer" means an intermediate protective coating applied over the electrodeposition primer and under the topcoat. Primer-surfacer provides adhesion, protection, and appearance properties to the total finish. Primer-surfacer may also be called guidecoat or surfacer. Primer-surfacer operations may include other coatings (e.g., anti-chip, lower-body anti-chip, chip-resistant edge primer, spot primer, blackout, deadener, interior color, basecoat replacement coating, etc.) that are applied in the same spray booth.
- (154) "Printing line" means an operation consisting of a series of one or more roll printers and any associated in-line roll coaters, in-line extrusion coaters, drying areas and ovens wherein one or more surface coatings are applied, dried, or cured. ~~It is not necessary for an~~ An operation does not need to have an oven or drying area in order to be included within this definition.
- (155) "Publication rotogravure printing line" means a rotogravure printing line in which surface coatings are applied to paper which is subsequently formed into books, catalogues, brochures, directories, newspaper supplements or other types of printed materials.
- (156) "Reactive adhesive" means an adhesive system composed, in part, of volatile monomers that react during the adhesive curing reaction, and, as a result, do not evolve from the film during use. These volatile components instead become integral parts of the adhesive through chemical reaction. At least seventy per cent of the liquid components of the system, excluding water, react during the process.
- (157) "Red coating" means a coating which meets all of the following criteria:
- (a) Yellow limit: the hue of hostaperm scarlet.
 - (b) Blue limit: the hue of monastral red-violet.
 - (c) Lightness limit for metallics: thirty-five per cent aluminum flake.
 - (d) Lightness limit for solids: fifty per cent titanium dioxide white.

(e) Solid reds: hue angle of negative eleven to positive thirty-eight degrees and maximum lightness of twenty-three to forty-five units.

(f) Metallic reds: hue angle of negative sixteen to positive thirty-five degrees and maximum lightness of twenty-eight to forty-five units.

These criteria are based on Cielab color space, 0/45 geometry. For spherical geometry, specular included, the upper limit is forty-nine units. The maximum lightness varies as the hue moves from violet to orange. This is a natural consequence of the strength of the colorants, and real colors show this effect.

(158) "Repair coating" means a coating used to re-coat portions of a previously coated product which has sustained mechanical damage to the coating following normal painting operations.

(159) "Resist coating" means a coating that is applied to a plastic part before metallic plating to prevent deposits of metal on portions of the plastic part.

(160) "Roll coat" means a coating method using a machine that applies coating to a substrate by continuously transferring coating through a pair or set of oppositely rotating rollers.

(161) "Roll coater" means an apparatus in which a uniform layer of coating material is applied by means of a roll or rolls across the entire width of a moving substrate, which is fed from an unwinding roll.

(162) "Roll printer" means an apparatus in which a surface coating is applied by means of a roll or rolls with only partial coverage across the width of a moving substrate, which is fed from an unwinding roll. The partial coverage results in the formation of words, designs or pictures on the substrate.

(163) "Rotogravure printing line" means a printing line in which each roll printer uses a roll with recessed areas for applying an image to the substrate.

(164) "Safety-indicating coating" means a coating which changes physical characteristics, such as color, to indicate unsafe conditions.

(165) "Shock-free coating" means a coating applied to electrical components to protect the user from electric shock. The coating has characteristics of being of low capacitance and high resistance, and having resistance to breaking down under high voltage.

(166) "Silicone-release coating" means any coating which contains silicone resin and is intended to prevent food from sticking to metal surfaces such as baking pans.

- (167) "Single coat" means a single film of coating applied directly to the substrate omitting the primer application.
- (168) "Side-seam" means the welded, cemented, or soldered seam of a three-piece can.
- (169) "Soft coat" means any coating that provides a soft tactile feel similar to leather and a rich leather like appearance when applied to plastic interior automotive parts and exterior business machine parts.
- (170) "Solar-absorbent coating" means a coating which has as its prime purpose the absorption of solar radiation.
- (171) "Solid-film lubricant" means a very thin coating consisting of a binder system containing as its chief pigment material one or more of molybdenum disulfide, graphite, polytetrafluoroethylene (PTFE) or other solids that act as a dry lubricant between faying surfaces.
- (172) "Solids turnover ratio" means the ratio of total volume of coating solids that is added to the EDP system in a calendar month divided by the total volume design capacity of the EDP system.
- (173) "Sound-proofing material" means a surface coating applied for the primary purpose of reducing the transmission of noise into or through the coated object.
- (174) "Steel pail or drum" means any single walled shipping container which has a capacity of one gallon or greater and which is cylindrically constructed of steel of twenty-nine gauge or heavier.
- (175) "Stencil coating" means the following:
- (a) For the surface coating of miscellaneous metal and plastic parts, an ink or a pigmented coating which is rolled or brushed onto a template or stamp in order to add identifying letters, symbols or numbers.
 - (b) For the surface coating of automotive/transportation and business machine plastic parts, a coating that is applied over a stencil to a plastic part at a thickness of one mil or less of coating solids. Stencil coats are most frequently letters, numbers, or decorative designs.
- (176) "Surfacer" means a surface coating applied to the body of an automobile or light-duty truck between the electrodeposition prime coat and the topcoat.

- (177) "Texture coat" or "texture coating" means a coating applied to a plastic part which, ~~in its~~when finished ~~form~~, consists of discrete raised spots of coating.
- (178) "Topcoat" means the following:
- (a) One or more surface coatings, excluding final repair, which are applied after the prime coat for desired aesthetic effects.
 - (b) For an automobile or light-duty truck assembly facility and a heavier vehicle assembly facility, the final coating system applied to provide the final color or a protective finish. The topcoat may be a monocoat color or basecoat/clearcoat system. In-line repair and two-tone are part of topcoat. Topcoat operations may include other coatings (e.g., blackout, interior color, etc.) that are applied in the same spray booths.
 - (c) For a pleasure craft, the final coating applied to the interior or exterior of the craft.
- (179) "Touch-up coating" means a coating used to cover minor coating imperfections appearing after the main coating operation.
- (180) "Transfer efficiency" means the percentage of total coating solids employed by a coating applicator which adheres to the object being coated.
- (181) "Translucent coating" means a coating which contains binders and pigment, and is formulated to form a colored, but not opaque, film.
- (182) "Two-component coating" means a coating requiring the addition of a separate reactive resin, commonly known as a catalyst, before application to form an acceptable dry film.
- (183) "Vacuum metallizing" means a process whereby metal is vaporized and deposited on a substrate in a vacuum chamber.
- (184) "Vacuum metallizing coating" means the following:
- (a) For the surface coating of miscellaneous metal and plastic parts, the undercoat applied to the substrate on which the metal is deposited or the overcoat applied directly to the metal film. Vacuum metallizing/physical vapor deposition (PVD) is the process whereby metal is vaporized and deposited on a substrate in a vacuum chamber.

- (b) For the surface coating of automotive/transportation and business machine plastic parts, a topcoat or basecoat that is used in the vacuum metallizing process.
- (185) "Varnish coating" means an oil-based surface coating applied directly over ink on a printed substrate for the purpose of enhancing or protecting the printed surface.
- (186) "Vinyl coating" means a coating or ink, not including organisol or plastisol coatings, applied to the surface of vinyl coated fabric, vinyl sheets, or other vinyl products by means of a knife coater, roll coater, or roll printer. ~~For purposes of this rule, "vinyl coating" shall not include organisol or plastisol coatings.~~
- (187) "Zinc rich primer coating" means any coating which contains primarily zinc pigment on a weight basis, which is applied as a prime coat to a metal part or product prior to assembly, and which is dried at ambient or in-plant temperature.
- (E) As used in paragraphs (L), (M), (T) and (Z) of rule 3745-21-09 of the Administrative Code (pertaining to storage tanks and to petroleum refinery equipment) and in rules 3745-21-04, 3745-21-10 and 3745-21-21 of the Administrative Code:
- (1) "Component" means any piece of equipment which has the potential to leak organic compounds into the atmosphere. Such equipment includes, but is not limited to, pump seals, compressor seals, seal oil degassing vents, pipeline valves, pressure relief devices, process drains and open ended pipes.
 - (2) "Condensate" means any organic compound separated from natural gas which condenses due to changes in the temperature or pressure and remains liquid at standard conditions.
 - (3) "Crude oil" means a naturally occurring mixture which consists of hydrocarbons or sulfur, nitrogen or oxygen derivatives of hydrocarbons and which is a liquid at standard conditions.
 - (4) "Custody transfer" means the transfer of produced crude oil or condensate, after processing or treating in the producing operations, from storage tanks or automatic transfer facilities to pipelines or any other forms of transportation.
 - (5) "External floating roof tank" means an open top storage vessel with a cover, consisting of a double deck or pontoon single deck, which rests upon and is supported by the contained liquid and which is equipped with a closure seal or seals to close the space between the roof edge and tank wall.

- (6) "Firebox" means the chamber or compartment of a boiler or furnace in which materials are burned, but does not mean the combustion chamber of an incinerator.
- (7) "Fixed roof tank" means a steel cylindrical shell with a permanently affixed roof.
- (8) "Flexible wiper primary seal" means a continuous sealing device mounted on the floating roof and equipped with an elastomeric blade which contacts the tank wall. It uses its own stiffness or other mechanical means to maintain contact with the tank wall.
- (9) "Gas service" means equipment which processes, transfers or contains an organic compound or mixture of organic compounds in the gaseous phase.
- (10) "Internal floating roof" means a cover or roof in a fixed roof tank which rests upon and is supported by the petroleum liquid being contained and is equipped with a closure seal or seals to close the space between the roof edge and tank shell.
- (11) "Liquid-mounted primary seal" means a seal constructed of an elastomeric coated fabric envelope and mounted onto the floating roof in such a manner that it touches the surface of the stored liquid.
- (12) "Liquid service" means equipment which processes, transfers or contains an organic compound or mixture of organic compounds in the liquid phase.
- (13) "Maximum true vapor pressure" means the equilibrium partial pressure exerted by the stored VOL, at the temperature equal to the highest calendar-month average of the VOL storage temperature for VOL's stored above or below the ambient temperature or at the local maximum monthly average temperature as reported by the national weather service for VOL's stored at the ambient temperature, as determined by one of the following:
- (a) In accordance with methods described in API MPMS Chapter 19.2 "Evaporative loss from external floating-roof tanks."
 - (b) As obtained from standard reference texts.
 - (c) By ASTM ~~D2879-10~~D2879.
 - (d) Any other method approved by the Ohio EPA.
- (14) "Mechanical shoe primary seal" means a seal constructed of metal sheets (shoes) which are joined together to form a ring, springs or levers which attach the

shoes to the floating roof and hold the shoes against the tank wall, and a coated fabric which is suspended from the shoes to the floating roof.

- (15) "Petroleum liquids" means crude oil, condensate, and any finished or intermediate products manufactured or extracted in a petroleum refinery.
- (16) "Petroleum refinery" means any facility engaged in producing gasoline, kerosene, distillate fuel oils, residual fuel oils, lubricants, or other products through distillation of crude oil, or through redistillation, cracking, extraction, or reforming of unfinished crude oil derivatives.
- (17) "Process unit turnaround" means a work practice or operational procedure that stops production from a refinery unit or part of a refinery unit. An unscheduled work practice or operational procedure that stops production from a refinery unit or part of a refinery unit for less than twenty-four hours is not a process unit turnaround. The use of spare equipment and technically feasible bypassing of equipment without stopping production are not process unit turnarounds.
- (18) "Refinery fuel gas" means any gas which is generated by a petroleum refinery process unit and which is combusted, including any gaseous mixture of natural gas and fuel gas.
- (19) "Refinery unit" means equipment assembled to produce intermediate or final products from crude oil, unfinished crude oil derivatives, or other intermediates. A refinery unit can operate independently if supplied with sufficient feed or raw materials and sufficient storage facilities for the product.
- (20) "Rim-mounted secondary seal" means a continuous sealing device located over the primary seal, mounted on the floating roof and extended to the tank wall. This device is not a weather shield.
- (21) "Shoe-mounted secondary seal" means a continuous sealing device extending from the top of the shoe (see the definition of mechanical shoe primary seal) to the tank wall.
- (22) "True vapor pressure" means the equilibrium partial pressure exerted by a petroleum liquid as determined in accordance with methods described in API MPMS Chapter 19.2 "Evaporative loss from external floating-roof tanks."
- (23) "Vacuum producing system" means any reciprocating, rotary, or centrifugal blower or compressor, or any jet ejector or device that takes suction from a pressure below atmospheric and discharges against atmospheric pressure.

- (24) "Valves not externally regulated" means valves that have no external controls, such as in-line valves.
- (25) "Vapor-mounted primary seal" means a seal constructed of an elastomeric coated fabric envelope and mounted onto the floating roof in such a manner that it does not touch the surface of the stored liquid.
- (26) "Volatile organic liquid" or "VOL" means any organic liquid which can emit VOCs as defined in this rule.
- (27) "Wastewater separator" means a device in which oil- contaminated water is skimmed to remove the floating oil prior to the discharge or further treatment of the water.
- (28) "Weather shield" means a device which is attached to a floating roof to protect the fabric of a liquid-mounted or vapor-mounted primary seal from weather and debris, thereby generally providing a longer primary seal life. The device is usually of leaf-type construction and has numerous radial joints to allow for roof movement or irregularities in the tank wall.
- (F) As used in paragraph (N) of rule 3745-21-09 of the Administrative Code (pertaining to the use of cutback asphalts and emulsified asphalts in road construction and maintenance) and in rule 3745-21-04 of the Administrative Code:
- (1) "Asphalt" means a dark brown to black cement-like material (solid, semisolid, or liquid in consistency) in which the predominating constituents are bitumens which occur in nature as such or which are obtained as residue in refining petroleum.
- (2) "Asphalt paving mixture" means a mixture of mineral aggregate and cutback asphalt, emulsified asphalt, or other asphaltic material.
- (3) "Cutback asphalt" means a mixture of asphalt and petroleum solvents (distillates), produced by blending those materials or by distilling petroleum.
- (4) "Dense-graded mix" means an asphalt paving mixture in which the air voids are less than ten per cent when compacted, as determined by ASTM ~~D3203~~ D3203M-11 D3203.
- (5) "Emulsified asphalt" means an emulsion of water and asphalt which may also contain emulsifying agents, special additives, and petroleum solvents (distillates).

- (6) "Maintenance mix" means an asphalt paving mixture for patching holes, depressions, and distressed areas in existing pavements.
 - (7) "Open-graded mix" means an asphalt paving mixture in which the air voids are equal to or greater than ten per cent when compacted, as determined by ASTM ~~D3203/D3203M-11~~D3203.
 - (8) "Prime coat" means an application of low-viscosity cutback asphalt or emulsified asphalt to an absorptive surface, designed to penetrate, bond and stabilize the existing surface and to promote adhesion between it and the construction course that follows.
- (G) As used in paragraph (O) of rule 3745-21-09 of the Administrative Code (pertaining to solvent metal cleaning) and in rules 3745-21-04 and 3745-21-10 of the Administrative Code:
- (1) "Cold cleaner" means a batch-operated device that employs a solvent for cleaning and removing soils from metal surfaces by spraying, brushing, flushing, agitation or immersion while maintaining the solvent below its boiling point. Wipe cleaning is not included in this definition.
 - (2) "Conveyorized degreaser" means a continuous-operated device for cleaning and removing soils from metal surfaces by the use of either non-vaporized or vaporized solvents.
 - (3) "Electronic component" means all portions of an electronic assembly, including, but not limited to, circuit board assemblies, printed wire assemblies, printed circuit boards, soldered joints, ground wires, bus bars, and associated electronic component manufacturing equipment such as screens and filters.
 - (4) "Freeboard height" means the following:
 - (a) For a cold cleaner, the distance from the solvent surface to the top edge of the degreaser tank.
 - (b) For an open top vapor degreaser, the distance from the top of the vapor zone to the top of the degreaser tank.
 - (5) "Freeboard ratio" means the freeboard height divided by the width of the degreaser air/solvent area. The same units of measurement should be used for all dimensions.

- (6) "Open top vapor degreaser" means a batch-operated device for cleaning and removing soils from metal surfaces by condensing hot solvent vapor on the colder metal parts.
 - (7) "Solvent" means any VOC which is liquid at standard conditions and which is used as a cleaning agent.
 - (8) "Solvent metal cleaning" means a process that employs a solvent for cleaning and removing soils from metal surfaces.
- (H) As used in paragraphs (P) to (R), (V), (GG), and (DDD) of rule 3745-21-09 of the Administrative Code (pertaining to bulk gasoline plants, bulk gasoline terminals, gasoline dispensing facilities, and gasoline tank trucks) and in rules 3745-21-04 and 3745-21-10 of the Administrative Code:
- (1) "Bottom filling" means the filling of a delivery vessel through an opening that is flush with the bottom of the delivery vessel's compartment.
 - (2) "Bulk gasoline plant" means a gasoline storage and distribution facility which receives gasoline primarily via delivery vessel, stores the gasoline in one or more stationary tanks, and subsequently dispenses the gasoline via delivery vessel.
 - (3) "Bulk gasoline terminal" means a gasoline storage and distribution facility which meets the following: receives gasoline primarily via pipeline, ship, or barge; stores the gasoline in one or more stationary tanks; and subsequently dispenses the gasoline primarily via delivery vessel.
 - (a) Receives gasoline primarily via pipeline, ship, or barge.
 - (b) Stores the gasoline in one or more stationary tanks.
 - (c) Subsequently dispenses the gasoline primarily via delivery vessel.
 - (4) "CARB certification" and "CARB certified" means the following:
 - (a) Subject to executive orders, approval letters, equipment advisories, and equivalent test procedures issued by California air resources board for phase I and phase II vapor control systems, parts, components, and test procedures used at gasoline dispensing facilities as follows:
 - (i) Issued on or before March 31, 2001 under pre-enhanced vapor recovery (pre-EVR) standards and certification procedures and issued after March 31, 2001 as a correction or revision, not related

to enhanced vapor recovery (EVR) standards, of phase I and phase II vapor control systems, parts, components, and test procedures previously approved under pre-EVR standards, however, gasoline dispensing facilities in Ohio ~~shall not be~~ are not subject to any provision or statement that specifies an expiration or decertification due to EVR standards and certification procedures; or

- (ii) Issued after March 31, 2001 under EVR standards and certification procedures for parts and components to be used in conjunction with pre-EVR systems, however, gasoline dispensing facilities in Ohio ~~shall not be~~ are not subject to any provision or statement that specifies an expiration or decertification due to EVR standards and certification procedures.

Additionally, where an owner or operator of a gasoline dispensing facility elects to use phase I or phase II vapor control systems, parts, components, or test procedures subject to executive orders, approval letters, equipment advisories, and equivalent test procedures issued by California air resources board under EVR standards and certification procedures, "CARB certification" and "CARB certified" ~~shall~~ also ~~mean~~ means such executive orders, approval letters, equipment advisories, and equivalent test procedures issued by California air resources board under EVR standards and certification procedures. (Executive orders that begin with "G" generally refer to pre-EVR systems, but may include provisions or statements on expiration or decertification due to EVR standards. Executive orders that begin with "VR" generally refer to EVR systems.)

- (b) Subject to executive orders, approval letters, equipment advisories, and equivalent test procedures issued by California air resource board that become effective for portable fuel containers and spouts on or after July 1, 2007.
- (5) "E85" means a fuel blend nominally consisting of eighty five per cent ethanol and fifteen per cent gasoline that meets the requirements of ASTM ~~D5798-12~~ D5798 for fuel ethanol.
- (6) "Delivery vessel" means a tank truck, a tank equipped trailer, a railroad tank car, or other mobile source, except ship or barge, equipped with a storage tank used for the transport of gasoline from a source of supply to stationary tanks at a gasoline dispensing facility or bulk gasoline plant.

- (7) "External floating roof" means a storage vessel cover in an open top tank consisting of a double deck or pontoon single deck which rests upon and is supported by the petroleum liquid being contained and is equipped with a closure seal or seals to close the space between the roof edge and tank shell.
- (8) "Gasoline" means any petroleum distillate which is used as a motor fuel and has a Reid vapor pressure of 4.0 pounds or greater.
- (9) "Gasoline dispensing facility" means any site where gasoline is dispensed to motor vehicle gasoline tanks from stationary storage tanks.
- (10) "Gasoline dispensing pump" means an individual unit at a gasoline dispensing facility with a dispensing nozzle where a specific grade of gasoline is dispensed to motor vehicle gasoline tanks.
- (11) "Gasoline tank truck" means any truck or trailer equipped with a storage tank which is used for the transport of gasoline to a stationary storage tank at a gasoline dispensing facility, bulk gasoline plant or bulk gasoline terminal.
- (12) "Independent small business marketer" means any owner of a gasoline dispensing facility engaged in the marketing of gasoline who would be required to pay for procurement and installation of a vapor control system pursuant to paragraph (DDD) of rule 3745-21-09 of the Administrative Code, except as any of the following:
- (a) The owner is a refiner.
 - (b) The owner controls, is controlled by, or is under common control with a refiner.
 - (c) The owner is otherwise directly or indirectly affiliated (as determined under the regulations of the USEPA) with a refiner or with a person who controls, is controlled by, or is under a common control with a refiner (unless the sole affiliation referred to herein is by means of a supply contract or an agreement or contract to use as a trademark, trade name, service mark, or other identifying symbol or name owned by such refiner or any such person).
 - (d) The owner receives less than fifty per cent of the owner's annual income from refining or marketing of gasoline.

For purposes of this definition, ~~the term "refiner" shall not include~~ means any refiner whose total refinery capacity (including the refinery capacity of any person who controls, is controlled by, or is under common control

with, such refiner) ~~does not exceed~~ exceeds sixty-five thousand barrels per day, and the term "control" of a corporation means ownership of more than fifty per cent of the corporation's stock.

- (13) "Internal floating roof" means a cover or roof in a fixed roof tank which rests upon and is supported by the petroleum liquid being contained and is equipped with a closure seal or seals to close the space between the roof edge and tank shell.
- (14) "Low permeation hoses" means hoses that meet UL 330.
- (15) "Reid vapor pressure" means the absolute vapor pressure of volatile crude oil and volatile nonviscous petroleum liquids except liquefied petroleum gases as determined by ASTM ~~D6897-09~~D6897.
- (16) "Submerged fill pipe" means any fill pipe the discharge opening of which is entirely submerged when the liquid level is six inches above the bottom of the tank, or when applied to a tank which is loaded from the side, ~~shall mean~~ means any fill pipe the discharge opening of which is entirely submerged when the liquid level is eighteen inches above the bottom of the tank.
- (17) "Top submerged filling" means the filling of a delivery vessel by means of a fill pipe which descends through an open hatch on the top of the delivery vessel to within six inches of the bottom of the delivery vessel's compartment.
- (18) "Topping off" means attempting to pump additional gasoline into a motor vehicle fuel tank after the dispensing nozzle has shut off automatically because the tank is full.
- (19) "Ullage" means the maximum storage tank capacity, in gallons, minus the gallons of gasoline present in the tank.
- (20) "Vapor balance system" means a combination of pipes or hoses which create a closed system between the vapor spaces of an unloading tank and a receiving tank such that vapors displaced from the receiving tank are transferred to the tank being unloaded.
- (21) "Vapor collection system" means a vapor transport system which forces vapors from a delivery vessel or storage tank into a vapor control system.
- (22) "Vapor control system" means control equipment designed to recover or incinerate organic compounds received from the vapor collection system.

- (23) "Vapor tight" means free of any vapor leaks to the extent possible based upon good engineering design and practice.
- (I) As used in paragraph (W) of rule 3745-21-09 of the Administrative Code (pertaining to synthesized pharmaceutical manufacturing facilities) and in rule 3745-21-04 of the Administrative Code:
- (1) "Production equipment exhaust system" means a device for collecting and directing out of the work area any fugitive emissions of organic compounds from openings on reactors, centrifuges and other vessels for the purpose of protecting workers from excessive exposure to such emissions.
 - (2) "Surface condenser" means a device which cools a gas stream to a temperature at which vapors are removed by means of condensation, where the coolant does not directly contact the condensed vapors.
 - (3) "Synthesized pharmaceutical manufacturing facility" means a facility in which drugs are produced by means of chemical synthesis.
- (J) As used in paragraph (X) of rule 3745-21-09 of the Administrative Code (pertaining to rubber tire manufacturing facilities) and in rules 3745-21-04 and 3745-21-10 of the Administrative Code:
- (1) "Bead dipping" means the dipping of an assembled tire bead into a solvent based cement.
 - (2) "Capture system" means any device or combination of devices designed to contain, collect, and route VOC vapors released from an operation at a rubber tire manufacturing facility.
 - (3) "Control system" means any device or combination of devices designed to recover or incinerate VOC vapors received from a capture system.
 - (4) "Green tires" means assembled tires before molding and curing have occurred.
 - (5) "Green tire spraying" means the spraying of green tires, both inside and outside, with release compounds which help remove air from the tire during molding and prevent the tire from sticking to the mold after curing.
 - (6) "Recapped tread stock" means vulcanized or unvulcanized rubber which is used for recapping tire carcasses and which is delivered to a recapping facility with a cement coating on one side.

- (7) "Rubber tire manufacturing facility" means a facility in which rubber tires or recapped tread stock are manufactured on a mass production basis.
 - (8) "Tread end cementing" means the application of a solvent based cement to the tire tread ends.
 - (9) "Undertread cementing" means the application of a solvent based cement to the underside of a tire tread.
- (K) As used in paragraphs (AA) and (BB) of rule 3745-21-09 of the Administrative Code (pertaining to dry cleaning facilities) and in rules 3745-21-04 and 3745-21-10 of the Administrative Code:
- (1) "Cartridge filter" means a discrete filter unit containing one or more disposable cartridges that contain both filter paper and activated carbon which trap and remove contaminants from the cleaning solvent.
 - (2) "Dry cleaning facility" means a facility engaged in the cleaning of articles of fabric in an essentially nonaqueous cleaning solvent by means of one or more washes in solvent, extraction of excess solvent by spinning, and drying by tumbling in an air stream. The facility includes, but is not limited to, washers, dryers, filtration and purification systems, waste disposal systems, holding tanks, pumps, and attendant piping and ductwork.
 - (3) "Dryer" means a machine used to remove cleaning solvent from articles, after washing and removing of excess cleaning solvent.
 - (4) "Manufacturer's rated capacity" means the capacity per load that is typically found on the manufacturer's name plate located on the equipment or in the manufacturer's equipment specifications.
 - (5) "Perchloroethylene dry cleaning facility" means a dry cleaning facility that uses perchloroethylene as the cleaning solvent.
 - (6) "Petroleum dry cleaning facility" means a dry cleaning facility that uses petroleum solvent as the cleaning solvent.
 - (7) "Petroleum solvent" means a material that is produced by petroleum distillation, that is composed mainly of hydrocarbons having a range of eight to twelve carbon atoms per molecule, and that exists as a liquid under standard conditions.
 - (8) "Solvent filter" means a discrete filter unit containing a porous medium that traps and removes contaminants from the cleaning solvent.

- (9) "Solvent recovery dryer" means a class of dryers that employ a condenser to condense and recover solvent vapors evaporated in a closed-loop stream of heated air.
- (L) As used in paragraph (CC) of rule 3745-21-09 of the Administrative Code (pertaining to continuous, polystyrene resin manufacturing process) and in rule 3745-21-04 of the Administrative Code:
- (1) "Continuous, polystyrene resin manufacturing process" means a process unit in which polystyrene resin is produced by the continuous polymerization or copolymerization of styrene monomer.
 - (2) "Material recovery section" means the section of the continuous, polystyrene resin manufacturing process that includes the vacuum devolatilizer and its associated condenser and vacuum system, and the styrene recovery distillation column and its associated condenser and vacuum system.
 - (3) "Styrene recovery distillation column" means a distillation column used to separate and recover styrene monomer from the vacuum devolatilizer stream containing unreacted styrene monomer and byproducts.
 - (4) "Vacuum devolatilizer" means a device in which the products from a polystyrene reactor are separated into a stream containing unreacted styrene monomer and byproducts and a stream containing molten polystyrene.
- (M) As used in paragraph (DD) of rule 3745-21-09 of the Administrative Code (pertaining to leaks from process units that produce organic chemicals) and in rules 3745-21-04 and 3745-21-10 of the Administrative Code:
- (1) "Btu/scf" means British thermal unit per standard cubic feet.
 - (2) "Closed vent system" means a system that is not open to the atmosphere and that is composed of piping, connections, and if necessary, flow inducting devices that transport gas or vapor from a piece or pieces of equipment to control equipment.
 - (3) "Connector" means a flanged, screwed, welded, or other joined fitting used to connect two pipelines or a pipeline and a piece of process equipment.
 - (4) "Distance piece" means an open or enclosed casing through which the piston rod travels, separating the compressor cylinder from the crankcase.
 - (5) "Double block and bleed system" means two block valves connected in series with a bleed valve or line that can vent the line between the two block valves.

- (6) "Equipment" means a pump, compressor, pressure relief device, sampling connection system, openended valve or line, valve, flange, connector, closed vent system, and any other device or system within a process unit.
- (7) "First attempt at repair" means to take rapid action for the purpose of stopping or reducing leakage from equipment.
- (8) [Reserved.]
- (9) "In gas/vapor service" means that the piece of equipment contains or contacts process fluid that is in the gaseous state at the operating conditions.
- (10) "In heavy liquid service" means that the piece of equipment is not in gas/vapor service or in light liquid service.
- (11) "In light liquid service" means that the piece of equipment contains or contacts process fluid that meets the conditions specified in paragraph (O) of rule 3745-21-10 of the Administrative Code.
- (12) "Insitu sampling system" means a nonextractive sampler or an in-line sampler.
- (13) "In vacuum service" means that the piece of equipment is operating at an internal pressure that is at least 0.7 pound per square inch below ambient pressure.
- (14) "In VOC service" means that the piece of equipment contains or contacts a process fluid that is at least ten per cent VOC by weight.
- (15) "Liquids dripping" means any visible leakage from the seal including spraying, misting, clouding, and ice formation.
- (16) "Open-ended valve or line" means any valve having one side of the valve seat in contact with the process fluid and one side open to the atmosphere, either directly or through open piping, but excluding any pressure relief valve.
- (17) "Ppmv" means parts per million by volume.
- (18) "Pressure release" means the emission of materials resulting from system pressure being greater than set pressure of the pressure relief device.
- (19) "Pressure relief device" means a pressure relief valve or a rupture disk.
- (20) "Pressure relief valve" means any valve designed to open when the process pressure exceeds a set pressure, allowing the release of vapors or liquids until the process pressure is reduced to ~~its~~the normal operating level.

- (21) "Process unit" means equipment assembled to produce, as intermediate or final products, one or more organic chemicals. A process unit can operate independently if supplied with sufficient feed or raw materials and sufficient storage facilities for the product.
- (22) "Process unit shutdown" means a work practice or operational procedure that stops production for a process unit or part of a process unit. An unscheduled work practice or operational procedure that stops production from a process unit or part of a process unit for less than twenty-four hours is not a process unit shutdown. The use of spare equipment and technically feasible bypassing of equipment without stopping production are not process unit shutdowns.
- (23) "Repaired" means that leaking equipment are successfully adjusted, or otherwise altered, in order to eliminate the leak.
- (24) "Rupture disk" means a disk made of a material that ruptures when the process pressure exceeds a set pressure, allowing the release of vapors or liquids until the process pressure is reduced to ambient pressure.
- (25) "Sensor" means a device that measures a physical quantity or the change in a physical quantity such as temperature, flow rate, "pH," or liquid level.
- (N) As used in paragraph (EE) of rule 3745-21-09 of the Administrative Code (pertaining to air oxidation processes that produce organic chemicals) and in rule 3745-21-04 of the Administrative Code:
- (1) "Air oxidation process" means a unit operation or process wherein organic chemicals are produced by reacting one or more compounds with oxygen which is supplied as air or air enriched with oxygen.
- (2) "Process vent stream" means any gas stream within the air oxidation process that vents to the ambient air.
- (O) [Reserved.]
- (P) As used in paragraph (LL) of rule 3745-21-09 of the Administrative Code (pertaining to "The Lubrizol Corporation," facility ID 0243000024):
- (1) "Air-bearing vent stream" means a process vent stream that contains a mixture of air and organic vapors.
- (2) "Reactor process" means reactor vessel equipment and associated material recovery equipment that are assembled to produce an organic chemical.

- (3) "Reactor process vent stream" means any gas stream within the reactor process that is vented to the ambient air, an enclosed combustion device, or a flare.
 - (4) "Wastewater separator" means a device in which contaminated water is skimmed to remove the floating organic materials prior to the discharge or further treatment of the water.
- (Q) As used in paragraph (MM) of rule 3745-21-09 of the Administrative Code (pertaining to "PPG Industries, Inc.," facility ID 1318000101):
- (1) "Control system" means any device or combination of devices designed to recover or incinerate VOC vapors received from a capture system.
 - (2) "Grinding mill" means a device used to grind or disperse pigment throughout a paint.
 - (3) "Paint manufacturing facility" means a facility engaged in the production of paints and includes, but is not limited to, mixing tanks, paint transfer equipment, grinding mills, equipment cleaning stations, and process tanks for paint tinting and thinning.
- (R) As used in paragraph (NN) of rule 3745-21-09 of the Administrative Code (pertaining to "Von Roll Isola USA, Inc., facility ID 1318002663):
- (1) "Mica coating or laminating line" means a series of one or more coating applicators and any associated flash-off areas, drying areas, and ovens wherein an adhesive coating or binder is applied to mica.
 - (2) "Oven" means a chamber within which heat is used for one or more of the following purposes: dry, bake, cure or polymerize an adhesive coating or binder.
- (S) As used in paragraph (OO) of rule 3745-21-09 of the Administrative Code (pertaining to "AK Steel Corporation," facility ID 1409010006):
- (1) "Aluminum coating operation" means an operation wherein a layer of aluminum is applied to the surface of metal coil by immersion into a bath of molten aluminum.
 - (2) "Anti-galling material" means a coating material applied directly to metal coil for the purpose of protecting the surface of the coil from damage during shipment.

- (3) "Metal coil treatment operation" means any operation where coating materials are applied directly to metal coil for the purpose of lubrication, rust prevention, or galling prevention.
 - (4) "Rolling oil" means a coating material which is applied directly to metal coil, for the purpose of lubrication, prior to processing at any temper mill.
 - (5) "Rust preventive oil" means a coating material which is applied directly to metal coil after processing at any temper mill or shear.
- (T) As used in paragraph (YY) of rule 3745-21-09 of the Administrative Code (pertaining to "PMC Specialties Group," facility ID 1431390137), paragraph (ZZ) of rule 3745-21-09 of the Administrative Code (pertaining to "Firestone Polymers," facility ID 1677010000), and paragraph (BBB) of rule 3745-21-09 of the Administrative Code (pertaining to "Emerald Performance Materials LLC," facility ID 1677010029):
- (1) "Air-bearing vent stream" means a process vent stream that contains a mixture of air and organic vapors.
 - (2) "Reactor process" means reactor vessel equipment and associated material recovery equipment that are employed to produce an organic chemical.
 - (3) "Reactor process vent stream" means any gas stream within the reactor process that is vented to control equipment or to the ambient air.
- (U) As used in rule 3745-21-12 of the Administrative Code:
- Except as otherwise provided in this paragraph, the definitions in rule 3745-15-01 of the Administrative Code and paragraph (B) of rule 3745-21-01 of the Administrative Code shall apply to rule 3745-21-12 of the Administrative Code (pertaining to control of volatile organic compound emissions from commercial bakery oven facilities).
- (1) "Baker's per cent" means, for a given ingredient, the weight of that ingredient per one hundred pounds of flour, expressed as a percentage.
 - (2) "Bakery oven" means an oven which bakes yeast-leavened products.
 - (3) "Commercial bakery oven facility" means an establishment that is primarily engaged in the manufacture, for sale at wholesale or retail, of fresh or frozen bread, bread-type rolls, or dry bakery products, including biscuits, crackers, or cookies, in which the products are made using yeast leavening.
 - (4) "Purge stack" means a bakery oven stack used only for exhausting residual gases from the bakery oven during burner ignition.

- (5) "Spike yeast" means any yeast added to the dough beyond the initial yeast added to the dough.
- (6) "Spiking time" means the elapsed time between the addition of the spike yeast to the dough and the placement of the dough into the oven.
- (7) "Subject to this rule" means the commercial bakery oven facility has met the applicability criteria of paragraph (A)(1) of rule 3745-21-12 of the Administrative Code and is subject to paragraphs (D) to (I) of rule 3745-21-12 of the Administrative Code.
- (8) "Total uncontrolled potential to emit" means the capability at maximum capacity of a commercial bakery oven facility to emit VOC under the commercial bakery oven facility's physical and operational design, excluding air pollution control equipment. Any physical or operational limitation on the capacity of the commercial bakery oven facility to emit VOC, including restrictions on the hours of operation or on the type or amount of material processed, but not including restrictions pertaining to air pollution control equipment, ~~shall be~~ are treated as part of ~~its~~ the physical and operational design if the limitation or the effect the limitation would have on VOC emissions is federally enforceable.
- (9) "Uncontrolled bakery oven" means a bakery oven in which the oven's VOC emissions are not vented to a VOC emission control device.
- (10) "Yeast action time" means the elapsed time between the initial addition of the yeast and the placement of the dough into the oven.
- (V) As used in rule 3745-21-13 of the Administrative Code:
- Except as otherwise provided in this paragraph, the definitions in rule 3745-15-01 of the Administrative Code and paragraph (B) of this rule ~~shall~~ apply to rule 3745-21-13 of the Administrative Code (pertaining to control of volatile organic compound emissions from reactors and distillation units employed in SOCOMI chemical production).
- (1) "Batch operation" means a noncontinuous operation in which a discrete quantity or batch of feed is charged into a unit operation within a process unit and distilled or reacted at one time. Batch operation includes noncontinuous operations in which the equipment is fed intermittently or discontinuously. Addition of raw material and withdrawal of product do not occur simultaneously in a batch operation. After each batch operation, the equipment is generally emptied before a fresh batch is started.

- (2) "Boiler" means any enclosed combustion device that extracts useful energy in the form of steam and is not an incinerator or a process heater.
- (3) "Btu" means British thermal unit.
- (4) "Car-seal" means a seal that is placed on a device that is used to change the position of a valve (e.g., from opened to closed) in such a way that the position of the valve cannot be changed without breaking the seal.
- (5) "Combustion device" means an individual unit of equipment, such as an incinerator, flare, boiler, or process heater, used for combustion of a vent stream discharged from the process vent.
- (6) "Compliance test" means the collection of data resulting from the execution of a test method used to demonstrate compliance with an emission limit or control requirement based on the average of three runs.
- (7) "Continuous record" means documentation, either in hard copy or computer readable form, of data values measured at least once every fifteen minutes and recorded as any of the following:
 - (a) Each measured value.
 - (b) Block average values for fifteen-minute or shorter periods calculated from all measured data values during each period or at least one measured data value per minute if measured more frequently than once per minute.
 - (c) Values under an alternative recordkeeping that is implemented in accordance with paragraph (H)(8) of rule 3745-21-13 of the Administrative Code.
- (8) "Continuous recorder" means a data recording device that either records an instantaneous data value at least once every fifteen minutes or records fifteen-minute or more frequent block average values.
- (9) "Control device" means any combustion device or recapture device. A recovery device is not considered a control device.
- (10) "Distillation operation" means an operation separating one or more feed stream into two or more exit streams, each exit stream having component concentrations different from those in the feed stream. The separation is achieved by the redistribution of the components between the liquid and vapor-phase as they approach equilibrium within the distillation unit.

- (11) "Distillation unit" means a device or vessel in which distillation operations occur, including all associated internals (such as trays or packing) and accessories (such as reboiler, condenser, vacuum pump, steam jet, etc.), plus any associated recovery system.
- (12) "Engineering assessment" means best estimate of a vent stream parameter (e.g., flow rate, VOC concentration, VOC emission rate, net heating value, etc.) that includes, but is not limited to, the following:
- (a) Previous test results provided the tests are representative of current operating practices at the process unit.
 - (b) Bench-scale or pilot-scale test data representative of the process under representative operating conditions.
 - (c) Maximum flow rate, VOC emission rate limit, VOC concentration limit, or net heating value limit specified or implied within a permit applicable to the process vent.
 - (d) Design analysis based on accepted chemical engineering principles, measurable process parameters, or physical or chemical laws or properties. Examples of analytical methods include, but are not limited to the following:
 - (i) Use of material balances based on process stoichiometry to estimate maximum VOC concentrations.
 - (ii) Estimation of maximum flow rate based on physical equipment design such as pump or blower capacities.
 - (iii) Estimation of VOC concentrations based on saturation conditions.
 - (iv) Estimation of maximum expected net heating value based on the vent stream concentration of each organic compound or, alternatively, as if all organic compounds in the vent stream were the organic compound with the highest heating value.
- (13) "Flame zone" means the portion of the combustion chamber in a boiler or process heater occupied by the flame envelope.
- (14) "Flow indicator" means a device that indicates whether gas flow is present in a vent stream.

- (15) "Fuel gas system" means the off-site and on-site piping and flow and pressure control system that gathers gaseous streams generated by on-site operations, may blend them with other sources of gas, and transports the gaseous stream for use as fuel gas in combustion devices or in-process combustion equipment such as furnaces and gas turbines either singly or in combination.
- (16) "Group 1 process vent" means a process vent for which a control device is required due to the TRE index value being less than or equal to 1.0. Also, monitoring of the control device is required, except when the control device is a boiler or process heater specified under paragraph (F)(1)(b) or (F)(1)(c) of rule 3745-21-13 of the Administrative Code.
- (17) "Group 2A process vent" means a process vent from a recovery system for which monitoring of the recovery system is required due to the TRE index value being less than or equal to 4.0, but a control device is not required due to the TRE index value being greater than 1.0.
- (18) "Group 2B process vent" means a process vent for which a control device and monitoring are not required due to any of the following:
- (a) The VOC concentration is less than five hundred ppmv.
 - (b) The flow rate is less than 0.30 scfm.
 - (c) The TRE index value is greater than 1.0 for a vent stream not from a recovery system.
 - (d) The TRE index value is greater than 4.0 for a vent stream from a recovery system.
- (19) "Halogenated vent stream" means a vent stream determined to have a mass emission rate of halogen atoms contained in organic compounds equal to or greater than 0.99 pound per hour.
- (20) "Halogens and hydrogen halides" means hydrogen chloride (HCl), chlorine (Cl₂), hydrogen bromide (HBr), bromine (Br₂), and hydrogen fluoride (HF).
- (21) "Incinerator" means an enclosed combustion device that is used for destroying organic compounds. Auxiliary fuel may be used to heat waste gas to combustion temperatures. Any energy recovery section present is not physically formed into one manufactured or assembled unit with the combustion section; rather, the energy recovery section is a separate section following the combustion section and the two are joined by ducts or connections carrying flue gas. The above

energy recovery section limitation does not apply to an energy recovery section used solely to preheat the incoming vent stream or combustion air.

- (22) "Monitoring device" means the total equipment used to measure and record (if applicable) process parameters.
- (23) "Nonhalogenated vent stream" means a vent stream that is not a halogenated vent stream.
- (24) "Organic monitoring device" means a device used to indicate the concentration level of organic compounds based on a detection principle such as infrared, photoionization, or thermal conductivity.
- (25) "Permit" means a permit issued by the director pursuant to Chapter 3745-31 or 3745-77 of the Administrative Code.
- (26) "Ppmv" means parts per million by volume.
- (27) "Primary fuel" mean the fuel that provides the principal heat input to the device. To be considered primary, the fuel must be able to sustain operation without the addition of other fuels.
- (28) "Process heater" means a device that transfers heat liberated by burning fuel to fluids contained in tubes, including all fluids except water that is heated to produce steam.
- (29) "Process unit" means equipment assembled and connected by pipes or ducts to produce, as a product (by-product, co-product, intermediate, or final product), one or more SOCFI chemicals. A process unit can operate independently if supplied with sufficient feed or raw materials and sufficient product storage facilities.
- (30) "Process vent" means the point of discharge to the atmosphere (or the point of entry into a control device, if any) of a gas stream from a distillation unit or reactor. Gas streams excluded from this definition are the following:
 - (a) A relief valve discharge.
 - (b) A leak from any device or equipment within a reactor or distillation unit (e.g., a leak from a pump, compressor, relief valve, or sampling system).
 - (c) A gas stream going to a fuel gas system.

- (d) A gas stream exiting a control device used to comply with rule 3745-21-13 of the Administrative Code.
 - (e) A gas stream transferred to other processes (on-site or off-site) for reaction or other use in another process (i.e., for chemical value as a product, isolated intermediate, by-product, or co-product, or for heat value).
 - (f) A gas stream transferred for fuel value (i.e., net positive heating value), use, reuse, or for sale for fuel value, use, or reuse.
 - (g) A gas stream exiting an analyzer.
- (31) "Product" means any SOCFI chemical which is produced for sale as a final product as that chemical, or for use in the production of other chemicals or compounds. By-products, co-products, and intermediates are considered to be products.
- (32) "Reactor" means a device or vessel in which reactor processes occur, including the product separator, any associated vacuum pump or steam jet, and any associated recovery system.
- (33) "Reactor process" means a process in which one or more chemicals, or reactants other than air, are combined or decomposed in such a way that their molecular structures are altered and one or more new organic compounds are formed.
- (34) "Recapture device" means an individual unit of equipment capable of and used for recovering chemicals from a gas stream, but not normally or primarily for use, reuse, or sale. For example, a recapture device may recover chemicals primarily for disposal or for air pollution control. Recapture devices include, but are not limited to, absorbers, carbon adsorbers, and condensers.
- (35) "Recovery device" means an individual unit of equipment, such as an absorber, carbon adsorber, or condenser, capable of and used for the purpose of recovering chemicals from a gas stream for fuel value (i.e., net positive heating value), use, reuse, or for sale for fuel value, use, or reuse.
- (36) "Recovery system" means an individual recovery device or series of such devices applied to the same vent stream.
- (37) "Relief valve" means a valve used only to release an unplanned, nonroutine discharge. A relief valve discharge results from an operator error, a malfunction such as a power failure or equipment failure, or other unexpected cause that requires immediate venting of gas from process equipment in order to avoid safety hazards or equipment damage.

- (38) "Run" means the net period of time during which an emission sample is collected or a test method is conducted.
- (39) "Scfm" means standard cubic feet per minute.
- (40) "Sensor" means a device that measures a physical quantity or the change in a physical quantity, such as temperature, pressure, flow rate, pH, or liquid level.
- (41) "Shutdown" means for purposes including, but not limited to, periodic maintenance, replacement of equipment, or repair, the cessation of operation of a reactor, distillation unit, or equipment required or used to comply with rule 3745-21-13 of the Administrative Code.
- (42) "SOCMI chemical" means a chemical listed in control of volatile organic compound emissions from reactor processes and distillation operations processes in the synthetic organic chemical manufacturing industry, appendix A, list of synthetic organic chemical manufacturing industry chemicals, Table A-1, list of synthetic organic chemical manufacturing industry chemicals, in the column titled reactor and distillation, EPA-450/4-91-031.
- (43) "Specific gravity monitoring device" means a unit of equipment used to monitor specific gravity and having a minimum accuracy of plus or minus 0.02 specific gravity units.
- (44) "Start-up" means the setting into operation of a reactor, distillation unit, or equipment required or used to comply with this rule. Start-up includes initial start-up, operation solely for testing equipment, and transitional conditions due to changes in product.
- (45) "Steam jet ejector" means a steam nozzle that discharges a high-velocity jet across a suction chamber that is connected to the equipment to be evacuated.
- (46) "Subject to this rule" means the reactor or distillation unit has met the applicability criteria of paragraph (A)(1) of rule 3745-21-13 of the Administrative Code.
- (47) "Temperature monitoring device" means a unit of equipment used to monitor temperature and having a minimum accuracy of plus or minus one per cent of the temperature being monitored expressed in degrees Celsius or plus or minus 0.5 degree Celsius, whichever is greater.
- (48) "Total organic compounds" or "TOC" means those compounds measured according to the procedures of USEPA method 18.

- (49) "Total resource effectiveness index value" or "TRE index value" means a measure of the supplemental total resource requirement per unit reduction of VOC associated with a vent stream, based on vent stream flow rate, emission rate of VOC, net heating value, and corrosion properties (whether or not the vent stream contains halogenated compounds) as determined using the equation in paragraph (E)(8)(a) of rule 3745-21-13 of the Administrative Code. The TRE index is a decision tool used to determine if the annual cost of controlling a given gas stream is reasonable when considering the emissions reduction achieved.
- (50) "TRE determination test" means the collection of data resulting from the execution of test methods used to demonstrate process vent flow rate and concentration, that are used to determine the process vent flow rate, net heating value, emission rates of TOC, VOC, and halogen atoms, each based on the average of three runs, for the determination of the TRE index value of a process vent.
- (51) "Vent stream" means the gas stream flowing through the process vent.
- (52) "Visible emission" means the observation of an emission of opacity or optical density above the threshold of vision.

(W) As used in rule 3745-21-14 of the Administrative Code:

Except as otherwise provided in this paragraph, the definitions in rule 3745-15-01 of the Administrative Code and paragraph (B) of this rule ~~shall~~ apply to rule 3745-21-14 of the Administrative Code (pertaining to control of volatile organic compound emissions from process vents in batch operations).

- (1) "Aggregate" means the summation of all process vents containing VOC within a process.
- (2) "Batch operation" means a noncontinuous operation in which a discrete quantity or batch of feed is charged into a unit operation within a batch process train and processed at one time. Batch operation includes noncontinuous operations in which the equipment is fed intermittently or discontinuously. Addition of raw material and withdrawal of product do not occur simultaneously in a batch operation. After each batch operation, the equipment is generally emptied before a fresh batch is started.
- (3) "Batch cycle" means a manufacturing event of an intermediate or product from start to finish in a batch process train.

- (4) "Batch process train" means the collection of equipment (e.g., reactors, filters, dryers, distillation columns, extractors, crystallizers, blend tanks, neutralizer tanks, digesters, surge tanks and product separators) configured to produce a specific product or intermediate by a batch operation. A batch process train terminates at the point of storage or product handling of the product or intermediate being produced in the batch process train. Irrespective of the product being produced, a batch process train which is independent of other processes ~~shall be~~ is considered a single batch process train for purposes of this rule definition.
- (5) "Boiler" means any enclosed combustion device that extracts useful energy in the form of steam.
- (6) "Continuous recorder" means a data recording device that either records an instantaneous data value at least once every fifteen minutes or records fifteen-minute or more frequent block average values.
- (7) "Control device" means any device or combination of devices designed to recover or destroy VOC vapors received from the process vents. A recovery device which is a required part of the process, for example, but not limited to, condensers operating under reflux conditions, is not a control device.
- (8) "Emission event" ~~shall be defined as~~ means a discrete period of venting that is associated with a unit operation. ~~For example, for example,~~ a displacement of vapor resulting from the charging of a unit operation with VOC ~~will result~~ resulting in a discrete emission event ~~that will last~~ lasting through the duration of the charge and ~~will have~~ having an average flow rate equal to the rate of the charge. The expulsion of expanded unit operation vapor space when the vessel is heated is also an emission event. Both of these examples of emission events and others may occur in the same unit operation during the course of the batch cycle. If the flow rate measurement for any discrete period of venting is zero, then such event is not an emission event for purposes of rule 3745-21-14 of the Administrative Code.
- (9) "Flame zone" means the portion of the combustion chamber in a boiler occupied by the flame envelope.
- (10) "Incinerator" means any enclosed combustion device that is used for destroying organic compounds. Auxiliary fuel may be used to heat waste gas to combustion temperatures. Any energy recovery section present is not physically formed into one section; rather, the energy recovery system is a separate section following the combustion section and the two are joined by ducting or connections that carry fuel gas.

- (11) "MmHg" means millimeters of mercury.
 - (12) "Permit" means a permit issued by the director pursuant to Chapter 3745-31 or 3745-77 of the Administrative Code.
 - (13) "Ppmv" means parts per million by volume.
 - (14) "Process vent" means a vent gas stream that is discharged from a unit operation or multiple unit operations within the same batch process train that are manifolded together into a common header. A process vent begins at the inlet to the control device prior to mixing with vent gas streams from other process trains or unrelated operations, or in the absence of a control device, at the point of discharge to the atmosphere. Not included in this definition are exhaust streams from exhaust hood and building ventilation fans which are used to provide ventilation for workers and not to collect and discharge emissions from specific unit operations. Process vents exclude relief valve discharges, leaks from equipment, vents from storage tanks, vents from transfer or loading operations, and vents from wastewater.
 - (15) "Recovery device" means an individual unit of equipment, such as an absorber, carbon adsorber, or condenser, capable of and used for the purpose of recovering chemicals for use, reuse, or sale.
 - (16) "Recovery system" means an individual recovery device or series of such devices applied to the same vent stream.
 - (17) "Standard industrial classification code" or "SIC code" means a series of four-digit codes devised by the office of management and budget (OMB) of the federal government to classify establishments according to the type of economic activity in which they are engaged.
 - (18) "Scfm" means standard cubic feet per minute.
 - (19) "Subject to this rule" means either the facility or the batch process train has met the applicability criteria of paragraph (A)(1) of rule 3745-21-14 of the Administrative Code.
 - (20) "Unit operation" means one or more pieces of process equipment used to make a single change to the physical or chemical characteristics of one or more process streams. Equipment used for these purposes includes, but is not limited to, reactors, filters, dryers, distillation columns, extractors, crystallizers, blend tanks, neutralizer tanks, digesters, surge tanks, and product separators.
- (X) As used in rule 3745-21-15 of the Administrative Code:

Except as otherwise provided in this paragraph, the definitions in rule 3745-15-01 of the Administrative Code and paragraph (B) of this rule ~~shall~~ apply to rule 3745-21-15 of the Administrative Code (pertaining to control of volatile organic compound emissions from wood furniture manufacturing operations).

- (1) "Adhesive" means any chemical substance that is applied for the purpose of bonding two surfaces together other than by mechanical means. Products but does not include products used on humans and animals, adhesive tape, contact paper, or any other product with an adhesive incorporated onto or in an inert substrate ~~shall not be considered adhesives~~.
- (2) "Aerosol adhesive" means an adhesive that is dispensed from a pressurized container as a suspension of fine solid or liquid particles in gas.
- (3) "As applied" means the VOC and solids content of the coating that is actually used for coating the substrate. ~~It~~This includes the contribution of materials used for in-house dilution of the coating.
- (4) "Basecoat" means a coat of colored material, usually opaque, that is applied before graining inks, glazing coats, or other opaque finishing materials, and is usually topcoated for protection.
- (5) "Capture device" means a hood, enclosed room, floor sweep, or other means of collecting solvent emissions or other pollutants into a duct so that the pollutant can be directed to a control device such as an incinerator or carbon adsorber.
- (6) "Capture efficiency" means the fraction of all organic vapors generated by a process that are directed to a control device.
- (7) "Capture system" means one or more capture devices intended to collect emissions generated by a finishing operation in the use of finishing materials, both at the point of application and at subsequent points where emissions from the finishing materials occur, such as flashoff, drying, or curing. Multiple capture devices that collect emissions generated by a finishing operation are considered a single capture system.
- (8) "Car-seal" means a seal that is placed on a device that is used to change the position of a valve (e.g., from opened to closed) in such a way that the position of the valve cannot be changed without breaking the seal.
- (9) "Certified product data sheet" or "CPDS" means documentation furnished by a coating supplier or an outside laboratory that provides the VOC content in percent by weight, the solids content in per cent by weight, other contents that may be of interest in per cent by weight, and the density of a coating

(finishing material or strippable spray booth material) or solvent, based on formulation data or measurement methods. For data based on a measurement method, the measurement method should be identified within the CPDS. The purpose of the CPDS is to assist the facility in demonstrating compliance with the emission limitations presented in paragraphs (D) and (E) of rule 3745-21-15 of the Administrative Code. Therefore, the VOC content should represent the maximum VOC emission potential of the coating or solvent. A CPDS includes, but is not limited to, technical data sheets, material specification sheets, material safety data sheets, and laboratory test reports pertaining to a coating or solvent.

- (10) "Cleaning operations" means operations in which organic solvent is used to remove coating materials from equipment used in wood furniture manufacturing operations.
- (11) "Coating" means a protective, decorative, or functional film applied in a thin layer to a surface. Such materials include, but are not limited to, paints, topcoats, varnishes, sealers, stains, washcoats, basecoats, enamels, inks, and temporary protective coatings. Aerosol spray paints used for touch-up and repair are not considered coatings under rule 3745-21-15 of the Administrative Code.
- (12) "Coating operation" means those activities in which a coating is applied to a substrate and is subsequently air-dried, cured in an oven, or cured by radiation.
- (13) "Compliant coating" means a finishing material or strippable spray booth material that meets the VOC content limits specified in paragraphs (D) and (E) of rule 3745-21-15 of the Administrative Code.
- (14) "Continuous coater" means a finishing system that continuously applies finishing materials onto furniture parts moving along a conveyor. Finishing materials that are not transferred to the part are recycled to a reservoir. Several types of application methods can be used with a continuous coater including spraying, curtain coating, roll coating, dip coating, and flow coating.
- (15) "Continuous compliance" means that the affected source is meeting the emission limitations and other requirements of the rule at all times and is fulfilling all monitoring and recordkeeping provisions of the rule in order to demonstrate compliance.
- (16) "Continuous recorder" means a data recording device that either records an instantaneous data value at least once every fifteen minutes or records fifteen-minute or more frequent block average values.

- (17) "Control device" means any equipment that reduces the quantity of an air pollutant that is emitted to the air. The device may destroy or secure the pollutant for subsequent recovery and includes, but is not limited to, thermal oxidizers, catalytic oxidizers, regenerative carbon adsorbers, and concentrators.
- (18) "Control device efficiency" means the ratio of the pollutant released by a control device and the pollutant introduced to the control device.
- (19) "Conventional air spray" means a spray coating method in which the coating is atomized by mixing it with compressed air and applied at an air pressure greater than ten pounds per square inch (gauge) at the point of atomization. Airless and air assisted airless spray technologies are not conventional air spray because the coating is not atomized by mixing it with compressed air. Electrostatic spray technology is also not considered conventional air spray because an electrostatic charge is employed to attract the coating to the workpiece.
- (20) [Reserved.]
- (21) "Dip coater" means a finishing operation that applies finishing materials by means of dip coating onto furniture parts.
- (22) "Emission" means the release or discharge, whether directly or indirectly, of VOC into the ambient air.
- (23) "Enamel" means a coat of colored material, usually opaque, that is applied as a protective topcoat over a basecoat, primer, or previously applied enamel coat. In some cases, another finishing material may be applied as a topcoat over the enamel. Under rule 3745-21-15 of the Administrative Code, an enamel is a topcoat.
- (24) "Finishing material" means a coating used in the wood furniture manufacturing industry. Such materials include, but are not limited to, stains, basecoats, washcoats, enamels, sealers, and topcoats. Under except that adhesives and nonpermanent final finish materials are not included under rule 3745-21-15 of the Administrative Code, ~~adhesives and nonpermanent final finish materials shall not be considered finishing materials.~~
- (25) "Finishing operation" means those operations in which a finishing material is applied to a substrate and is subsequently air-dried, cured in an oven, or cured by radiation.
- (26) "Flow indicator" means a device that indicates whether gas flow is present in a vent stream.

- (27) "Gluing operation" means those operations in which adhesives are used to join components, for example, to apply a laminate to a wood substrate or foam to fabric.
- (28) "Monitoring device" means the total equipment used to measure and record (if applicable) process parameters.
- (29) "Natural draft opening" means any opening in a room, building, or total enclosure that remains open during operation of the finishing operation and that is not connected to a duct in which a fan is installed. The rate and direction of the natural draft across such an opening is a consequence of the difference in pressures on either side of the wall or barrier containing the opening.
- (30) "Noncompliant coating" means a finishing material or strippable spray booth material that has a VOC content greater than the VOC content limit specified in paragraphs (D) and (E) of rule 3745-21-15 of the Administrative Code.
- (31) "Nonpermanent final finish material" means a material such as a wax, polish, nonoxidizing oil, or similar substance that must be periodically reapplied to a surface over its lifetime to maintain or restore the reapplied material's intended effect.
- (32) "Operating parameter value" means a minimum or maximum value established for a control device, capture system, or process parameter that, if achieved by itself or in combination with one or more other operating parameter values, determines that an owner or operator has complied with an applicable emission limit.
- (33) "Organic monitoring device" means a device used to indicate the concentration level of organic compounds based on a detection principle such as infrared, photoionization, or thermal conductivity.
- (34) "Overall control efficiency" means the efficiency of a VOC emission control system, calculated as the product of the capture system and control device efficiencies, expressed as a percentage.
- (35) "Permanent total enclosure" or "PTE" means a permanently installed enclosure that meets the criteria for a PTE in accordance with USEPA method 204 specified within paragraph (C)(3)(c) of rule 3745-21-10 of the Administrative Code, and that directs all the exhaust gases from the enclosure to a control device.
- (36) "Permit" means a permit issued by the director pursuant to Chapter 3745-31 or 3745-77 of the Administrative Code.

- (37) "Responsible official" has the same meaning as in rule 3745-77-01 of the Administrative Code.
- (38) "Sealer" means a finishing material used to seal the pores of a wood substrate before additional coats of finishing material are applied. Special purpose finishing materials that are used in some finishing systems to optimize aesthetics are not sealers.
- (39) "Solids" means the nonvolatile portion of the coating that makes up the dry film.
- (40) "Solvent" means a liquid used in a coating to dissolve or disperse constituents or to adjust viscosity. A solvent evaporates during drying and does not become a part of the dried film.
- (41) "Stain" means any color coat having a solids content by weight of no more than 8.0 per cent that is applied in single or multiple coats directly to the substrate. A stain includes, but is not limited to, nongrain raising stains, equalizer stains, prestains, sap stains, body stains, no-wipe stains, penetrating stains, and toners.
- (42) "Strippable spray booth material" means a coating that meets the following:
- (a) Is applied to a spray booth wall to provide a protective film to receive over spray during finishing operations.
 - (b) Is subsequently peeled off and disposed.
 - (c) Reduces or eliminates the need to use VOC solvents to clean spray booth walls due to achieving paragraphs (X)(42)(a) and (X)(42)(b) of this rule.
- (43) "Subject to this rule" means the facility has met the applicability criteria of paragraph (A) of rule 3745-21-15 of the Administrative Code.
- (44) "Substrate" means the surface onto which a coating is applied (or into which a coating is impregnated).
- (45) "Temperature monitoring device" means a unit of equipment used to monitor temperature and having a minimum accuracy of plus or minus one per cent of the temperature being monitored expressed in degrees Celsius or plus or minus 0.5 degree Celsius, whichever is greater.
- (46) "Thinner" means a volatile liquid that is used to dilute coatings (to reduce viscosity, color strength, and solids, or to modify drying conditions).

- (47) "Topcoat" means the last film-building finishing material that is applied in a finishing system. Nonpermanent final finishes are not topcoats.
- (48) "Touchup and repair" means the application of finishing materials to cover minor finishing imperfections.
- (49) "VOC emission control system" means the combination of capture and control devices used to reduce VOC emissions to the atmosphere.
- (50) "VOC solvent" means a VOC liquid used for dissolving or dispersing constituents in a coating, adjusting the viscosity of a coating, or cleaning equipment. When used in a coating, the VOC solvent evaporates during drying and does not become a part of the dried film.
- (51) "Washcoat" means a transparent special purpose finishing material having a solids content by weight of 12.0 per cent by weight or less. Washcoats are applied over initial stains to protect, to control color, and to stiffen the wood fibers in order to aid sanding.
- (52) "Washoff operations" means those operations in which VOC solvent is used to remove coating from wood furniture or a wood furniture component.
- (53) "Wood furniture" means any product made of wood, a wood product such as rattan or wicker, or an engineered wood product such as particleboard that is manufactured under any of the following standard industrial classification (SIC) codes: 2434, 2511, 2512, 2517, 2519, 2521, 2531, 2541, 2599, or 5712.
- (54) "Wood furniture component" means any part that is used in the manufacture of wood furniture. Examples include, but are not limited to, drawer sides, cabinet doors, seat cushions, and laminated tops. However, foam seat cushions manufactured and fabricated at a facility that does not engage in any other wood furniture or wood furniture component manufacturing operation are excluded from this definition.
- (55) "Wood furniture manufacturing operations" means the finishing, gluing, cleaning, and washoff operations associated with the production of wood furniture or wood furniture components.

(Y) As used in rule 3745-21-16 of the Administrative Code:

Except as otherwise provided in this paragraph, the definitions in rule 3745-15-01 of the Administrative Code and paragraph (B) of this rule ~~shall~~ apply to rule 3745-21-16 of the Administrative Code (pertaining to control of volatile organic compound emissions from industrial wastewater).

- (1) "Affected industrial category" means any of the following industrial categories:
 - (a) Organic chemicals, plastics, and synthetic fibers manufacturing industry under standard industrial classification (SIC) codes 2821, 2823, 2824, 2865, and 2869.
 - (b) Pesticides manufacturing industry under SIC code 2879.
 - (c) Pharmaceutical manufacturing industry under SIC codes 2833, 2834, and 2836.
 - (d) Hazardous waste treatment, storage, and disposal facilities industry under SIC codes 4952, 4953, and 4959.
- (2) "Affected residual" means a residual that is removed from an affected VOC wastewater stream.
- (3) "Affected VOC" means VOC with a Henry's Law Constant greater than or equal to 1.8×10^{-6} atmosphere-cubic meter/mole ($\text{atm} \cdot \text{m}^3/\text{mole}$) (0.1 y/x) at twenty-five degrees Celsius.
- (4) "Affected VOC wastewater stream" means a process wastewater stream from a process unit at an affected industrial category with either an annual average concentration of affected VOC greater than or equal to ten thousand parts per million by weight (ppmw) or an annual average concentration of affected VOC greater than or equal to one thousand ppmw and an annual average flow rate greater than or equal to 10.0 liters per minute (2.64 gallons per minute), as determined in accordance with paragraph (I) of rule 3745-21-16 of the Administrative Code (relating to "Determination of wastewater characteristics"). The following are excluded from this definition:
 - (a) Maintenance wastewaters.
 - (b) Stormwater from segregated sewers.
 - (c) Water from fire-fighting and deluge systems, including testing of such systems.
 - (d) Spills.
 - (e) Water from safety showers.
 - (f) Samples of a size not greater than reasonably necessary for the method of analysis that is used.

- (g) Equipment leaks.
 - (h) Wastewater drips from procedures such as disconnecting hoses after cleaning lines.
 - (i) Noncontact cooling water.
- (5) "Annual average concentration" means the flow-weighted annual average concentration, as determined according to the procedures specified 40 CFR 60.782(b).
- (6) "Annual average flow rate" means the annual average flow rate, as determined according to the procedures specified in paragraph (I) of rule 3745-21-16 of the Administrative Code.
- (7) "Closed biological treatment process" means a tank or surface impoundment where biological treatment occurs and VOC emissions from the treatment process are routed either to a control device by means of a closed vent system or to a fuel gas system by means of hard-piping. The tank or surface impoundment has a fixed roof, as defined in this rule, or a floating flexible membrane cover that meets the requirements specified in paragraph (I) of rule 3745-21-16 of the Administrative Code.
- (8) "Closed-vent system" means a system that is not open to the atmosphere and is composed of hard-piping, ductwork, connections, and, if necessary, flow inducing devices that transport gas or vapor from an emission point to a control device.
- (9) "Combustion device" means an individual unit of equipment, such as a flare, incinerator, process heater, or boiler, used for the combustion of volatile organic compound emissions.
- (10) "Continuous seal" means a seal that forms a continuous closure that completely covers the space between the wall of the storage vessel and the edge of the floating roof. A continuous seal may be a vapor-mounted, liquid-mounted, or metallic shoe seal. A continuous seal may be constructed of fastened segments so as to form a continuous seal.
- (11) "Continuously monitor and record" means to measure data values of a parameter at least once every fifteen minutes and to record either each measured data value or block average values for a fifteen-minute or shorter time period. A block average value is the average of all measured data values during the time period; or if data values are measured more frequently than once per minute,

the average of measured data values taken at least once per minute during the time period.

- (12) "Control device means" any combustion device, recovery device for vapor vents, or recapture device. Such equipment includes, but is not limited to, absorbers, carbon adsorbers, condensers, incinerators, flares, boilers, and process heaters. For a steam stripper, a primary condenser is not considered a control device.
- (13) "Cover" means a device or system which is placed on or over a waste management unit containing wastewater or residuals so that the entire surface area is enclosed to minimize air VOC emissions. A cover may have openings necessary for operation, inspection, and maintenance of the waste management unit such as access hatches, sampling ports, and gauge wells provided that each opening is closed when not in use. Examples of covers include a fixed roof installed on a wastewater tank, a lid installed on a container, and an air-supported enclosure installed over a waste management unit.
- (14) "Ductwork" means a conveyance system such as those commonly used for heating and ventilation systems. Ductwork is often made of sheet metal and often has sections connected by screws or crimping. Hard-piping is not ductwork.
- (15) "Enhanced biological treatment process" means an aerated, thoroughly mixed treatment unit that contains biomass suspended in water followed by a clarifier that removes biomass from the treated water and recycles recovered biomass to the aeration unit. The mixed liquor volatile suspended solids (biomass) is greater than one kilogram per cubic meter throughout each aeration unit. The biomass is suspended and aerated in the water of the aeration unit by either submerged air flow or mechanical agitation. A thoroughly mixed treatment unit is a unit that is designed and operated to approach or achieve uniform biomass distribution and organic compound concentration throughout the aeration unit by quickly dispersing the recycled biomass and the wastewater entering the unit.
- (16) "External floating roof" means a pontoon-type or double-deck-type cover that rests on the liquid surface in a storage vessel or waste management unit with no fixed roof.
- (17) "Fixed roof" means a cover that is mounted on a waste management unit or storage vessel in a stationary manner and that does not move with fluctuations in liquid level.

- (18) "Floating roof" means a cover consisting of a double deck, pontoon single deck, internal floating cover or covered floating roof, which rests upon and is supported by the liquid being contained, and is equipped with a closure seal or seals to close the space between the roof edge and waste management unit.
- (19) "Fbio" means site-specific fraction of VOC biodegraded, unitless.
- (20) "Fe" means fraction emitted value, unitless.
- (21) "Fm" means compound-specific fraction measured factor, unitless.
- (22) "Fr" means fraction removed value for VOC, unitless.
- (23) "Fuel gas system" means the off-site and on-site piping and control system that gathers gaseous stream generated by on-site operations, may blend them with other sources of gas, and transports the gaseous stream for use as fuel gas in combustion devices or in in-process combustion equipment such as furnaces and gas turbines, either singly or in combination.
- (24) "Hard-piping" means pipe or tubing that is manufactured and properly installed using good engineering judgment and standards, such as ANSI B31-3.
- (25) "Incinerator" means an enclosed combustion device that is used for destroying organic compounds. Auxiliary fuel may be used to heat waste gas to combustion temperatures. Any energy recovery section present is not physically formed into one manufactured or assembled unit with the combustion section; rather, the energy recovery section is a separate section following the combustion section and the two are joined by ducts or connections carrying flue gas. The above energy recovery section limitation does not apply to an energy recovery section used solely to preheat the incoming vent stream or combustion air.
- (26) "Individual drain system" means the stationary system used to convey wastewater streams or residuals to a waste management unit or to discharge or disposal. The term includes hard-piping, all process drains and junction boxes, together with their associated sewer lines and other junction boxes, manholes, sumps, and lift stations, conveying wastewater streams or residuals. A segregated storm water sewer system, which is a drain and collection system designed and operated for the sole purpose of collecting rainfall-runoff at a facility, and which is segregated from all other individual drain systems, is excluded from this definition.
- (27) "Internal floating roof" means a cover that rests or floats on the liquid surface (but not necessarily in complete contact with the liquid surface) inside a waste management unit that has a fixed roof.

- (28) "Junction box" means a manhole or a lift station, or access point to a wastewater sewer line.
- (29) "Liquid-mounted seal" means a foam or liquid-filled seal mounted in contact with the liquid between the wall of the storage vessel or waste management unit and the floating roof. The seal is mounted continuously around the circumference of the vessel or unit.
- (30) "Maintenance wastewater" means wastewater generated by the draining of process fluid from components in the process unit into an individual drain system prior to or during maintenance activities. Maintenance wastewater can be generated during planned and unplanned shutdowns and during periods not associated with a shutdown. Any generation of wastewater that is routine or is generated by designed manufacturing processes is not maintenance wastewater. Examples of activities that can generate maintenance wastewaters include descaling heat exchanger tubing bundles, cleaning of distillation column traps, draining of low legs and high point bleeds, draining of pumps into an individual drain system and draining of portions of the process unit for repair.
- (31) "Maximum true vapor pressure" means the equilibrium partial pressure exerted by the organics in the stored or transferred liquid at the temperature equal to the highest calendar-month average of the liquid storage or transfer temperature for liquids stored or transferred above or below the ambient temperature or at the local maximum monthly average temperature as reported by the national weather service for liquids stored or transferred at the ambient temperature, as determined by any of the following:
- (a) In accordance with methods described in API MPMS Chapter 19.2 "Evaporative loss from external floating-roof tanks."
 - (b) As obtained from standard reference texts.
 - (c) As determined by ASTM ~~D2879-10~~D2879.
 - (d) Any other method approved by the director.
- (32) "Mechanical shoe seal" means metal sheets that are held vertically against the wall of the storage vessel by springs, weighted levers, or other mechanisms and connected to the floating roof by braces or other means. A flexible coated fabric (envelope) spans the annular space between the metal sheet and the floating roof.
- (33) "Oil-water separator" or "organic-water separator" means a waste management unit, used to separate oil or organics from water. An oil-water or organic-

water separator consists of not only the separation unit but also the forebay and other separator basins, skimmers, weirs, grit chambers, sludge hoppers, and bar screens that are located directly after the individual drain system and prior to additional treatment units such as an air flotation unit, clarifier, or biological treatment unit. Examples of an oil-water or organic-water separator include, but are not limited to, an American Petroleum Institute separator, parallel-plate interceptor, and corrugated-plate interceptor with the associated ancillary equipment.

- (34) "Open biological treatment process" means a biological treatment process that is not a closed biological treatment process as defined in this rule.
- (35) "Plant" means the same as facility.
- (36) "Point of generation" means the location where process wastewater exits a process unit.
- (37) "Point of determination" means each point where process wastewater exits a process unit.
- (38) "Pressure relief valve" means a valve used only to release an unplanned, non-routine discharge. A relief valve discharge can result from an operator error, a malfunction such as a power failure or equipment failure, or other unexpected cause that requires immediate venting of gas from process equipment in order to avoid safety hazards or equipment damage.
- (39) "Process drain" means any opening (including a covered or controlled opening) that is installed or used to receive or convey wastewater into the wastewater system.
- (40) "Process unit" means the smallest set of process equipment that can operate independently and includes all operations necessary to achieve the process objective.
- (41) "Process wastewater" means wastewater which, during manufacturing or processing, comes into direct contact with or results from the production or use of any raw material, intermediate product, finished product, by-product, or waste product. Examples are product tank drawdown or feed tank drawdown; water formed during a chemical reaction or used as a reactant; water used to wash impurities from organic products or reactants; water used to cool or quench organic vapor streams through direct contact; and condensed steam from jet ejector systems pulling vacuum on vessels containing organics.
- (42) "RCRA" means the Resource Conservation and Recovery Act.

- (43) "Recapture device" means an individual unit of equipment capable of and used for the purpose of recovering chemicals, but not normally for use, reuse, or sale. For example, a recapture device may recover chemicals primarily for disposal. Recapture devices include, but are not limited to, absorbers, carbon adsorbers, and condensers.
- (44) "Recovery device" means an individual unit of equipment capable of and normally used for the purpose of recovering chemicals for fuel value (i.e., net positive heating value), use, reuse or for sale for fuel value, use, or reuse. Examples of equipment that may be recovery devices include absorbers, carbon adsorbers, condensers, oil-water separators or organic-water separators, or organic removal devices such as decanters, strippers, or thin-film evaporation units. For purposes of the monitoring, recordkeeping, and reporting requirements of this subpart, recapture devices are considered recovery devices.
- (45) "Residual" means any liquid or solid material containing VOC that is removed from a wastewater stream by a waste management unit or treatment process that does not destroy organic compounds (nondestructive unit). Examples of residuals from nondestructive wastewater management units are: the organic layer and bottom residue removed by a decanter or organic-water separator and the overheads from a steam stripper or air stripper. Examples of materials which are not residuals are: silt; mud; leaves; bottoms from a steam stripper or air stripper; and sludges, ash, or other materials removed from wastewater being treated by destructive devices such as biological treatment units and incinerators.
- (46) "Sewer line" means a lateral, trunk line, branch line, or other conduit including, but not limited to, grates and trenches, used to convey wastewater streams or residuals to a downstream waste management unit.
- (47) "Single-seal system" means a floating roof having one continuous seal that completely covers the space between the wall of the storage vessel and the edge of the floating roof. This seal may be a vapor-mounted, liquid-mounted, or metallic shoe seal.
- (48) "Steam jet ejector" means a steam nozzle which discharges a high-velocity jet across a suction chamber that is connected to the equipment to be evacuated.
- (49) "Steam stripper" means a column (including associated stripper feed tanks, condensers, or heat exchangers) used to remove compounds from wastewater.
- (50) "Surface impoundment" means a waste management unit which is a natural topographic depression, manmade excavation, or diked area formed primarily

of earthen materials (although it may be lined with manmade materials), which is designed to hold an accumulation of liquid wastes or waste containing free liquids. A surface impoundment is used for the purpose of treating, storing, or disposing of wastewater or residuals, and is not an injection well. Examples of surface impoundments are equalization, settling, and aeration pits, ponds, and lagoons.

- (51) "Tank drawdown" means any material or mixture of materials discharged from a product tank, feed tank, or intermediate tank for the purpose of removing water or other contaminants from the tank.
- (52) "Temperature monitoring device" means a unit of equipment used to monitor temperature and having a minimum accuracy of (a) plus or minus one per cent of the temperature being monitored expressed in degrees Celsius or (b) plus or minus 0.5 degree Celsius, whichever number is greater (i.e., has the highest absolute value).
- (53) "Treatment process" means a specific technique that removes or destroys the organics in a wastewater or residual stream such as a steam stripping unit (steam stripper), thin-film evaporation unit, waste incinerator, biological treatment unit, or any other process applied to wastewater streams or residuals to comply with paragraph (D)(8) or (E) of rule 3745-21-16 of the Administrative Code. Most treatment processes are conducted in tanks. Treatment processes are a subset of waste management units.
- (54) "Vapor-mounted seal" means a continuous seal that completely covers the annular space between the wall of the storage vessel or waste management unit and the edge of the floating roof and is mounted such that there is a vapor space between the stored liquid and the bottom of the seal.
- (55) "Waste management unit" means the equipment, structure, or device used to convey, store, treat, or dispose of wastewater streams or residuals. Examples of waste management units include: wastewater tanks, surface impoundments, individual drain systems, and biological wastewater treatment units. Examples of equipment that may be waste management units include containers, air flotation units, oil-water separators or organic-water separators, or organic removal devices such as decanters, strippers, or thin-film evaporation units. If such equipment is used for recovery then the equipment is part of a process unit and is not a waste management unit.
- (56) "Wastewater stream" means a stream that contains process wastewater.

- (57) "Wastewater tank" means a stationary waste management unit that is designed to contain an accumulation of wastewater or residuals and is constructed primarily of non-earthen materials (e.g., wood, concrete, steel, plastic) which provide structural support. Wastewater tanks used for flow equalization are included in this definition.
- (58) "Water seal controls" means a seal pot, p-leg trap, or other type of trap filled with water (e.g., flooded sewers that maintain water levels adequate to prevent air flow through the system) that creates a water barrier between the water level of the seal and the atmosphere. The water level of the seal must be maintained in the vertical leg of a drain in order to be considered a water seal.
- (59) "Wet weather retention basin" means an impoundment or tank that is used to store rainfall runoff that would exceed the capacity of the wastewater treatment system until ~~it~~ the runoff can be returned to the wastewater treatment system or, if the water meets the applicable discharge limits, discharged without treatment. The wet weather retention basins may also be used to store wastewater during periods when the wastewater treatment system is shut down for maintenance or emergencies.

(Z) As used in rule 3745-21-17 of the Administrative Code:

Except as otherwise provided in this paragraph, the definitions in rule 3745-15-01 of the Administrative Code and paragraph (B) of this rule ~~shall~~ apply to rule 3745-21-17 of the Administrative Code (pertaining to portable fuel containers).

- (1) "Fuel" means all gasoline, gasoline-alcohol mixtures or blends, diesel, kerosene or petroleum derivatives, having a true vapor pressure within the range of 1.5 to eleven pounds per square in absolute (psia) (10.3 to 75.6) for use in internal combustion engines or aircraft.
- (2) "Manufacturer" means any person who imports, manufactures, assembles, packages, repackages, or re-labels a portable fuel container or spout or both portable fuel container and spout.
- (3) "Nominal capacity" means the volume indicated by the manufacturer that represents the maximum recommended filling level.
- (4) "Outboard engine" means a spark-ignition marine engine that, when properly mounted on a marine water-craft in the position to operate, houses the engine and drive unit external to the hull of the marine water-craft.
- (5) "Person" means any individual, public or private corporation, political subdivision, government agency, department or bureau of the State,

municipality, industry, co-partnership, association, firm, estate or any legal entity whatsoever.

- (6) "Portable fuel container" means any container or vessel with a nominal capacity of ten gallons or less intended for reuse that is designed, or used, sold, advertised or offered for sale primarily for receiving, transporting, storing, and dispensing fuel or kerosene. Portable fuel containers do not include containers permanently embossed, or affixed with a permanent durable label with wording indicating such containers are solely intended for use with non-fuel or non-kerosene products.
- (7) "Spout" means any device that can be firmly attached to a portable fuel container for conducting pouring or fueling through which the contents of a portable fuel container can be dispensed.
- (8) "Target fuel tank" means any receptacle that receives fuel from a portable fuel container.

(AA) As used in rule 3745-21-19 of the Administrative Code:

- (1) "Ablative coating" means a coating that chars when exposed to open flame or extreme temperatures, as would occur during the failure of an engine casing or during aerodynamic heating. The ablative char surface serves as an insulative barrier, protecting adjacent components from the heat or open flame.
- (2) "Adhesion promoter" means a very thin coating applied to a substrate to promote wetting and form a chemical bond with the subsequently applied material.
- (3) "Adhesive bonding primer" means a primer applied in a thin film to aerospace components for the purpose of corrosion inhibition and increased adhesive bond strength by attachment. There are two categories of adhesive bonding primers: primers with a design cure at two hundred fifty degrees Fahrenheit or below and primers with a design cure above two hundred fifty degrees Fahrenheit.
- (4) "Adhesive primer" means a coating that conforms to one of the following:
 - (a) Inhibits corrosion and serves as a primer applied to bare metal surfaces or prior to adhesive application.
 - (b) Is applied to surfaces that can be expected to contain fuel, however, fuel tank coatings are excluded from this definition.

- (5) "Aerosol coating" means a coating expelled from a handheld, pressurized, non-refillable container in a finely divided spray when a valve on the container is depressed.
- (6) "Aerospace manufacturing or rework facility" means any facility that produces, reworks, or repairs in any amount any commercial, civil, or military aerospace vehicle or component.
- (7) "Aerospace vehicle or component" means any fabricated part, processed part, assembly of parts, or completed unit, with the exception of electronic components, of any aircraft including but not limited to airplanes, helicopters, missiles, rockets, and space vehicles.
- (8) "Aircraft fluid systems" means those systems that handle hydraulic fluids, fuel, cooling fluids, or oils.
- (9) "Aircraft transparency" means the aircraft windshield, canopy, passenger windows, lenses and other components which are constructed of transparent materials.
- (10) "Antichafe coating" means a coating applied to areas of moving aerospace components that may rub during normal operations or installation.
- (11) "Antique aerospace vehicle or component" means an aircraft or component thereof that was built at least thirty years ago. An antique aerospace vehicle would not routinely be in commercial or military service in the capacity for which the vehicle was designed.
- (12) "Aqueous cleaning solvent" means a solvent in which water is at least eighty per cent of the solvent as applied. Detergents, surfactants, and bioenzyme mixtures and nutrients may be combined with the water along with a variety of additives, such as organic solvents (e.g., high boiling point alcohols), builders, saponifiers, inhibitors, emulsifiers, pH buffers, and antifoaming agents. Aqueous solutions must have a flash point greater than ninety-three degrees Celsius (two hundred degrees Fahrenheit) (as reported by the manufacturer), and the solution must be miscible with water.
- (13) "Bearing coating" means a coating applied to an antifriction bearing, a bearing housing, or the area adjacent to such a bearing in order to facilitate bearing function or to protect base material from excessive wear. ~~A material shall~~ but is not be classified as a bearing coating if the material can also be classified as a dry lubricative material or a solid film lubricant.

- (14) "Bonding maskant" means a temporary coating used to protect selected areas of aerospace parts from strong acid or alkaline solutions during processing for bonding.
- (15) "Caulking and smoothing compounds" means semi-solid materials which are applied by hand application methods and are used to aerodynamically smooth exterior vehicle surfaces or fill cavities such as bolt hole accesses, but does not include materials that may also be classified as a sealant. ~~A material shall not be classified as a caulking and smoothing compound if the material can also be classified as a sealant.~~
- (16) "Chemical agent-resistant coating" or "CARC" means an exterior topcoat designed to withstand exposure to chemical warfare agents or the decontaminants used on these agents.
- (17) "Chemical milling maskant" means a coating that is applied directly to aluminum components to protect surface areas when chemical milling the component with a Type I or Type II etchant. Type I chemical milling maskants are used with a Type I etchant and Type II chemical milling maskants are used with a Type II etchant. This definition does not include bonding maskants, critical use, line sealer maskants, and seal coat maskants. Additionally, maskants that must be used with a combination of Type I or II etchants and any of the above types of maskants (i.e., bonding, critical use and line sealer, and seal coat) are also exempt from this subpart. (See also Type I and Type II etchant definitions.)
- (18) "Cleaning operation" means collectively spray gun, hand wipe, and flush cleaning operations.
- (19) "Cleaning solvent" means a liquid material used for hand wipe, spray gun, or flush cleaning. This definition does not include solutions that contain VOC at concentrations less than 0.1 per cent by weight for carcinogens and less than 1.0 per cent by weight for non-carcinogens, as determined from manufacturer's representations.
- (20) "Clear coating" means a transparent coating usually applied over a colored opaque coating, metallic substrate, or placard to give improved gloss and protection to the color coat. A clearcoat refers to any transparent coating without regard to substrate.
- (21) "Coating" means a material that is applied to the surface of an aerospace vehicle or component to form a decorative or functional solid film, or the solid film itself.

- (22) "Coating line" means an operation consisting of a series of one or more coating applicators and any associated flash-off areas, drying areas and ovens wherein a coating is applied, dried, or cured. The coating line does not have to include an oven, or flash-off area, or drying area in order to be included within this definition.
- (23) "Coating operation" means the use of a spray booth, tank, or other enclosure or any area, such as a hangar, for the application of a single type of coating (e.g., primer). The use of the same spray booth, tank, or other enclosure or area for the application of another type of coating (e.g., topcoat) constitutes a separate coating operation for which compliance determinations are performed separately.
- (24) "Commercial exterior aerodynamic structure primer" means a primer used on aerodynamic components and structures that protrude from the fuselage, such as wings and attached components, control surfaces, horizontal stabilizers, vertical fins, wing-to-body fairings, antennae, and landing gear and doors, for the purpose of extended corrosion protection and enhanced adhesion.
- (25) "Commercial interior adhesive" means materials used in the bonding of passenger cabin interior components. These components must meet the FAA fire worthiness requirements.
- (26) "Compatible epoxy primer" means a primer that is compatible with the filled elastomeric coating and is epoxy based. This compatible substrate primer is an epoxy-polyamide primer used to promote adhesion of elastomeric coatings such as impact-resistant coatings.
- (27) "Compatible substrate primer" means a primer that is either a compatible epoxy primer or an adhesive primer.
- (28) "Confined space" means a space that conforms to the following:
- (a) Is large enough and so configured that an employee can bodily enter and perform assigned work.
 - (b) Has limited or restricted means for entry or exit (for example, fuel tanks, fuel vessels, and other spaces that have limited means of entry).
 - (c) Is not suitable for continuous employee occupancy.
- (29) "Corrosion prevention compound" means a coating that provides corrosion protection by displacing water and penetrating mating surfaces, forming a

protective barrier between the metal surface and moisture. Coatings containing oils or waxes are excluded from this definition.

- (30) "Critical use and line sealer maskant" means a temporary coating, not covered under other maskant categories, used to protect selected areas of aerospace parts from strong acid or alkaline solutions such as those used in anodizing, plating, chemical milling and processing of magnesium, titanium, or high strength steel, high precision aluminum chemical milling of deep cuts, and aluminum chemical milling of complex shapes. Materials used for repairs or to bridge gaps left by scribing operations (i.e., line sealer) are also included in this category.
- (31) "Cryogenic flexible primer" means a primer designed to provide corrosion resistance, flexibility, and adhesion of subsequent coating systems when exposed to loads up to and surpassing the yield point of the substrate at cryogenic temperatures (minus two hundred seventy-five degrees Fahrenheit and below).
- (32) "Cryoprotective coating" means a coating that insulates cryogenic or subcooled surfaces to limit propellant boil-off, maintain structural integrity of metallic structures during ascent or re-entry, and prevent ice formation.
- (33) "Cyanoacrylate adhesive" means a fast-setting, single component adhesive that cures at room temperature. Cyanoacrylate adhesive is also known by the tradename "super glue."
- (34) "DOD" means the United States department of defense, including military departments and defense agencies, acting through either the secretary of defense or the designee of the secretary.
- (35) "Dry lubricative material" means a coating consisting of lauric acid, cetyl alcohol, waxes, or other non-cross linked or resin-bound materials which act as a dry lubricant.
- (36) "Electric or radiation-effect coating" means a coating or coating system engineered to interact, through absorption or reflection, with specific regions of the electromagnetic energy spectrum, such as the ultraviolet, visible, infrared, or microwave regions. Uses include, but are not limited to, lightning strike protection, electromagnetic pulse protection, and radar avoidance. Coatings that have been designated "classified" by the department of defense are exempt.
- (37) "Electrostatic discharge and electromagnetic interference coating" or "EMI coating" means a coating applied to space vehicles, missiles, aircraft radomes,

and helicopter blades to disperse static energy or reduce electromagnetic interference.

- (38) "Electrostatic spray" means a method of applying a spray coating in which an electrical charge is applied to the coating and the substrate is grounded. The coating is attracted to the substrate by the electrostatic potential between the coating and the substrate.
- (39) "Elevated temperature Skydrol-resistant commercial primer" means a primer applied primarily to commercial aircraft (or commercial aircraft adapted for military use) that must withstand immersion in phosphate-ester hydraulic fluid (Skydrol 500b or equivalent) at the elevated temperature of one hundred fifty degrees Fahrenheit for one thousand hours.
- (40) "Epoxy polyamide topcoat" means a coating used where harder films are required or in some areas where engraving is accomplished in camouflage colors.
- (41) "Exterior primer" means the first layer and any subsequent layers of identically formulated coating applied to the exterior surface of an aerospace vehicle or component where the component is used on the exterior of the aerospace vehicle. Exterior primers are typically used for corrosion prevention, protection from the environment, functional fluid resistance, and adhesion of subsequent exterior topcoats. Coatings that are defined as specialty coatings are not included under this definition.
- (42) "FAA" means the federal aviation administration, department of transportation, United States.
- (43) "Fire-resistant (interior) coating" means the following:
 - (a) For civilian aircraft, a coating used on passenger cabin interior parts that are subject to the FAA fireworthiness requirements;
 - (b) For military aircraft, a coating used on parts that are subject to the flammability requirements of MIL-STD-1330C(SH) and MIL-A-87721.
 - (c) For space applications, a coating used on parts that are subject to the flammability requirements of SE-R-0006 and SSP 30233F.
- (44) "Flexible primer" means a primer that meets flexibility requirements such as those needed for adhesive bond primed fastener heads or on surfaces expected to contain fuel. The flexible coating is required because it provides a compatible, flexible substrate over bonded sheet rubber and rubber-type

coatings as well as a flexible bridge between the fasteners, skin, and skin-to-skin joints on outer aircraft skins. This flexible bridge allows more topcoat flexibility around fasteners and decreases the chance of the topcoat cracking around the fasteners. The result is better corrosion resistance.

- (45) "Flight test coating" means a coating applied to aircraft other than missiles or single-use aircraft prior to flight testing to protect the aircraft from corrosion and to provide required marking during flight test evaluation.
- (46) "Fuel tank adhesive" means an adhesive used to bond components exposed to fuel and must be compatible with fuel tank coatings.
- (47) "Fuel tank coating" means a coating applied to fuel tank components for the purpose of corrosion or bacterial growth inhibition and to assure sealant adhesion in extreme environmental conditions.
- (48) "General aviation" or "GA" means that segment of civil aviation that encompasses all facets of aviation except air carriers, commuters, and military. General aviation includes charter and corporate-executive transportation, instruction, rental, aerial application, aerial observation, business, pleasure, and other special uses.
- (49) "General aviation rework facility" means any aerospace facility with the majority of revenues resulting from the reconstruction, repair, maintenance, repainting, conversion, or alteration of general aviation aerospace vehicles or components.
- (50) "Hand wipe cleaning operation" means removing contaminants such as dirt, grease, oil, and coatings from an aerospace vehicle or component by physically rubbing the contaminant with a material such as a rag, paper, or cotton swab that has been moistened with a cleaning solvent.
- (51) "High temperature coating" means a coating designed to withstand temperatures of more than three hundred fifty degrees Fahrenheit.
- (52) "High volume low pressure spray equipment" or "HVLP spray equipment" means spray equipment that is used to apply coating by means of a spray gun that operates at 10.0 pounds per square inch gauge of atomizing air pressure or less at the air cap.
- (53) "Insulation covering" means material that is applied to foam insulation to protect the insulation from mechanical or environmental damage.

- (54) "Intermediate release coating" means a thin coating applied beneath topcoats to assist in removing the topcoat in depainting operations and generally to allow the use of less hazardous depainting methods.
- (55) "Lacquer" means a clear or pigmented coating formulated with a nitrocellulose or synthetic resin to dry by evaporation without a chemical reaction. Lacquers are resolvable in ~~their~~the original solvent.
- (56) "Large commercial aircraft" means an aircraft of more than one hundred ten thousand pounds, maximum certified take-off weight manufactured for non-military use.
- (57) "Leak" means any visible leakage, including misting and clouding.
- (58) "Limited access space" means internal surfaces or passages of an aerospace vehicle or component that cannot be reached without the aid of an airbrush or a spray gun extension for the application of coatings.
- (59) "Metalized epoxy coating" means a coating that contains relatively large quantities of metallic pigmentation for appearance or added protection.
- (60) "Mold release" means a coating applied to a mold surface to prevent the molded piece from sticking to the mold during removal.
- (61) "Nonstructural adhesive" means an adhesive that bonds nonload bearing aerospace components in noncritical applications and is not covered in any other specialty adhesive categories.
- (62) "Operating parameter value" means a minimum or maximum value established for a control equipment or process parameter that, if achieved by itself or in combination with one or more other operating parameter values, determines that an owner or operator has complied with an applicable emission limitation.
- (63) "Optical anti-reflection coating" means a coating with a low reflectance in the infrared and visible wavelength ranges that is used for antireflection on or near optical and laser hardware.
- (64) "Part marking coating" means coatings or inks used to make identifying markings on materials, components, or assemblies. These markings may be either permanent or temporary.
- (65) "Pretreatment coating" means an organic coating that contains at least 0.5 per cent acids by weight and is applied directly to metal surfaces to provide surface etching, corrosion resistance, adhesion, and ease of stripping.

- (66) "Primer" means the first layer and any subsequent layers of identically formulated coating applied to the surface of an aerospace vehicle or component. Primers are typically used for corrosion prevention, protection from the environment, functional fluid resistance, and adhesion of subsequent coatings. Primers that are defined as specialty coatings are not included under this definition.
- (67) "Radome" means the nonmetallic protective housing for electromagnetic transmitters and receivers (e.g., radar, electronic countermeasures, etc.).
- (68) "Rain erosion-resistant coating" means a coating or coating system used to protect the leading edges of parts such as flaps, stabilizers, radomes, engine inlet nacelles, etc. against erosion caused by rain impact during flight.
- (69) "Research and development operation" means an operation whose purpose is for research and development of new processes and products, that is conducted under the close supervision of technically trained personnel and is not involved in the manufacture of final or intermediate products for commercial purposes, except in a de minimis manner.
- (70) "Rocket motor bonding adhesive" means an adhesive used in rocket motor bonding applications.
- (71) "Rocket motor nozzle coating" means a catalyzed epoxy coating system used in elevated temperature applications on rocket motor nozzles.
- (72) "Rubber-based adhesive" means a quick setting contact cement that provide a strong, yet flexible bond between two mating surfaces that may be of dissimilar materials.
- (73) "Scale inhibitor" means a coating that is applied to the surface of a part prior to thermal processing to inhibit the formation of scale.
- (74) "Screen print ink" means a inks used in screen printing processes during fabrication of decorative laminates and decals.
- (75) "Seal coat maskant" means an overcoat applied over a maskant to improve abrasion and chemical resistance during production operations.
- (76) "Sealant" means a material used to prevent the intrusion of water, fuel, air, or other liquids or solids from certain areas of aerospace vehicles or components. There are two categories of sealants: extrudable/rollable/brushable sealants and sprayable sealants.

- (77) "Self-priming topcoat" means a topcoat that is applied directly to an uncoated aerospace vehicle or component for purposes of corrosion prevention, environmental protection, and functional fluid resistance. More than one layer of identical coating formulation may be applied to the vehicle or component.
- (78) "Semiaqueous cleaning solvent" means a solution in which water is a primary ingredient (greater than sixty per cent of the solvent solution as applied must be water.)
- (79) "Silicone insulation material" means an insulating material applied to exterior metal surfaces for protection from high temperatures caused by atmospheric friction or engine exhaust. These materials differ from ablative coatings in that ~~they~~ the materials are not "sacrificial."
- (80) "Solids" means the nonvolatile portion of the coating that after drying makes up the dry film.
- (81) "Solid film lubricant" means a very thin coating consisting of a binder system containing a chief pigment material containing one or more of the following: molybdenum, graphite, polytetrafluoroethylene, or other solids that act as a dry lubricant between faying surfaces.
- (82) "Space vehicle" means a man-made device, either manned or unmanned, designed for operation beyond earth's atmosphere. This definition includes integral equipment such as models, mock-ups, prototypes, molds, jigs, tooling, hardware jackets, and test coupons. Also included is auxiliary equipment associated with test, transport, and storage, which through contamination can compromise the space vehicle performance.
- (83) "Specialty coating" means a coating that, even though the coating meets the definition of a primer, topcoat, or self-priming topcoat, has additional performance criteria beyond those of primers, topcoats, and self-priming topcoats for specific applications. These performance criteria may include, but are not limited to, temperature or fire resistance, substrate compatibility, antireflection, temporary protection or marking, sealing, adhesively joining substrates, or enhanced corrosion protection. A listing of specialty coatings is found in paragraph (D)(1)(b) of rule 3745-21-19 of the Administrative Code.
- (84) "Specialized function coating" means a coating that fulfills extremely specific engineering requirements that are limited in application and are characterized by low volume usage. This category excludes coatings covered in other specialty coating categories.

- (85) "Spray gun" means a device that atomizes a coating or other material and projects the particulates or other material onto a substrate.
- (86) "Structural autoclavable adhesive" means an adhesive used to bond load carrying aerospace components that is cured by heat and pressure in an autoclave.
- (87) "Structural non-autoclavable adhesive" means an adhesive cured under ambient conditions that is used to bond load carrying aerospace components or other critical functions, such as nonstructural bonding in the proximity of engines.
- (88) "Surface preparation" means the removal of contaminants from the surface of an aerospace vehicle or component or the activation or reactivation of the surface in preparation for the application of a coating.
- (89) "Temporary protective coating" means a coating applied to provide scratch or corrosion protection during manufacturing, storage, or transportation. Two types include peelable protective coatings and alkaline removable coatings. These materials are not intended to protect against strong acid or alkaline solutions. Coatings that provide this type of protection from chemical processing are not included in this category.
- (90) "Thermal control coating" means a coatings formulated with specific thermal conductive or radiative properties to permit temperature control of the substrate.
- (91) "Topcoat" means a coating that is applied over a primer on an aerospace vehicle or component for appearance, identification, camouflage, or protection. Topcoats that are defined as specialty coatings are not included under this definition.
- (92) "Touchup and repair coating" means a coating used to cover minor coating imperfections appearing after the main coating operation.
- (93) "Type II etchant" means a chemical milling etchant that is a strong sodium hydroxide solution containing amines.
- (94) "Type I etchant" means a chemical milling etchant that contains varying amounts of dissolved sulfur and does not contain amines.
- (95) "VOC composite vapor pressure" means the sum of the partial pressures of the compounds defined as VOC in this rule, as determined according to the procedures specified in paragraph (S) of rule 3745-21-10 of the Administrative Code.

- (96) "Waterborne (water-reducible) coating" means a coating which contains more than five per cent water by weight as applied in its volatile fraction.
- (97) "Wet fastener installation coating" means a primer or sealant applied by dipping, brushing, or daubing to fasteners that are installed before the coating is cured.
- (98) "Wing coating" means a corrosion-resistant topcoat that is resilient enough to withstand the flexing of the wings.

(BB) As used in rule 3745-21-20 of the Administrative Code:

- (1) "Add-on control system" means an air pollution control device such as a carbon adsorber or incinerator that reduces pollution in an air stream by destruction or removal prior to discharge to the atmosphere.
- (2) "Air flask coating" means any special composition coating applied to interior surfaces of high pressure breathing air flasks to provide corrosion resistance and that is certified safe for use with breathing air supplies.
- (3) "Antenna coating" means any coating applied to equipment through which electromagnetic signals must pass for reception or transmission.
- (4) "Antifoulant coating" means any coating that is applied to the underwater portion of a vessel to prevent or reduce the attachment of biological organisms and that is registered with the USEPA as a pesticide under the Federal Insecticide, Fungicide, and Rodenticide Act.
- (5) "As applied" means the condition of a coating at the time of application to the substrate, including any thinning solvent.
- (6) "As supplied" means the condition of a coating before any thinning, as sold and delivered by the coating manufacturer to the user.
- (7) "Batch" means the product of an individual production run of a coating manufacturer's process. A batch may vary in composition from other batches of the same product.
- (8) "Bitumens" mean black or brown materials that are soluble in carbon disulfide and consist mainly of hydrocarbons.
- (9) "Bituminous resin coating" means any coating that incorporates bitumens as a principal component and is formulated primarily to be applied to a substrate or surface to resist ultraviolet radiation or water.

- (10) "Chemical Agent Resistant Coating" or "CARC" means a military exterior coating.
- (11) "Coating" means any material that can be applied as a thin layer to a substrate and which cures to form a continuous solid film.
- (12) "Cold-weather time period" means any time during which the ambient temperature is below 4.5 degrees Celsius (forty degrees Fahrenheit) and coating is to be applied.
- (13) "Container of coating" means the container from which the coating is applied, including but not limited to a bucket or pot.
- (14) "Cure volatiles" means reaction products which are emitted during the chemical reaction which takes place in some coating films at the cure temperature. These emissions are other than those from the solvents in the coating and may, in some cases, comprise a significant portion of total VOC emissions.
- (15) "Epoxy coating" means any thermoset coating formed by reaction of an epoxy resin (i.e., a resin containing a reactive epoxide with a curing agent).
- (16) "General use coating" means any coating that is not a specialty coating.
- (17) "Heat resistant coating" means any coating that during normal use must withstand a temperature of at least two hundred four degrees Celsius (four hundred degrees Fahrenheit).
- (18) "High-gloss coating" means any coating that achieves at least eighty-five per cent reflectance on a sixty-degree meter when tested by ASTM ~~D523-08~~D523.
- (19) "High-temperature coating" means any coating that during normal use must withstand a temperature of at least four hundred twenty-six degrees Celsius (eight hundred degrees Fahrenheit).
- (20) "Inorganic zinc (high-build) coating" means a coating that contains eight pounds per gallon (nine hundred sixty grams per liter) or more elemental zinc incorporated into an inorganic silicate binder that is applied to steel to provide galvanic corrosion resistance.
- (21) "Interior coating" means any coating used on interior surfaces aboard United States military vessels pursuant to a coating specification that requires the coating to meet specified fire retardant and low toxicity requirements, in addition to the other applicable military physical and performance requirements.

- (22) "Marine coating" means any coating that is applied to ships.
- (23) "Maximum allowable thinning ratio" means the maximum volume of thinner that can be added per volume of coating without violating the VOC content limits of paragraph (D)(1) of rule 3745-21-20 of the Administrative Code.
- (24) "Military exterior coating" means any exterior topcoat applied to military or USCG vessels that are subject to specific chemical, biological, and radiological washdown requirements.
- (25) "Mist coating" means any low viscosity, thin film, epoxy coating applied to an inorganic zinc primer that penetrates the porous zinc primer and allows the occluded air to escape through the paint film prior to curing.
- (26) "Navigational aids coating" means any coating applied to USCG buoys or other USCG waterway markers when they are recoated aboard ship at the usage site and immediately returned to the water.
- (27) "Nonskid coating" means any coating applied to the horizontal surfaces of a marine vessel for the specific purpose of providing slip resistance for personnel, vehicles, or aircraft.
- (28) "Nonvolatiles" means substances that do not evaporate readily. This term refers to the film-forming material of a coating.
- (29) "Normally closed" means a container or piping system is closed unless an operator is actively engaged in adding or removing material.
- (30) "Nuclear coating" means any protective coating used to seal porous surfaces such as steel (or concrete) that otherwise would be subject to intrusion by radioactive materials. These coatings must be resistant to long-term (service life) cumulative radiation exposure (ASTM ~~D4082-10~~D4082), relatively easy to decontaminate (ASTM ~~D4256-89(1994)e1~~D4256), and resistant to various chemicals to which the coatings are likely to be exposed (ASTM ~~D3912-10~~D3912). [For nuclear coatings, see the general protective requirements outlined by the United States nuclear regulatory commission in a report entitled "Regulatory guide 1.54 - service level I, II and III protective coatings applied to nuclear plants."]
- (31) "Operating parameter value" means a minimum or maximum value established for a control device or process parameter that, if achieved by itself or in combination with one or more other operating parameter values, determines that an owner or operator has complied with an applicable emission limitation.

- (32) "Organic zinc coating" means any coating derived from zinc dust incorporated into an organic binder that contains more than eight pounds of elemental zinc per gallon (nine hundred sixty grams per liter) of coating, as applied, and that is used for the expressed purpose of corrosion protection.
- (33) "Pleasure craft" means any marine or fresh-water vessel used by individuals for noncommercial, nonmilitary, and recreational purposes that is less than twenty meters in length. ~~A vessel including vessels~~ rented exclusively to or chartered by individuals for such purposes ~~shall be considered a pleasure craft.~~
- (34) "Pretreatment wash primer" means any coating that contains a minimum of 0.5 per cent acid, by mass, and is applied only to bare metal to etch the surface and enhance adhesion of subsequent coatings.
- (35) "Repair and maintenance of thermoplastic coating" means any vinyl, chlorinated rubber, or bituminous resin coating that is applied over the same type of existing coating to perform the partial recoating of any in-use commercial vessel. This definition does not include coal tar epoxy coatings, which are considered "general use" coatings.
- (36) "Rubber camouflage coating" means any specially formulated epoxy coating used as a camouflage topcoat for exterior submarine hulls and sonar domes.
- (37) "Sealant coating for thermal spray aluminum" means any epoxy coating applied to thermal spray aluminum surfaces at a maximum thickness of one dry mil.
- (38) "Ship" means any marine or fresh-water vessel used for military or commercial operations, including self-propelled vessels, those propelled by other craft (barges), and navigational aids (buoys). This definition includes, but is not limited to, all military and USCG vessels, commercial cargo and passenger (cruise) ships, ferries, barges, tankers, container ships, patrol and pilot boats, and dredges. Pleasure crafts and offshore oil and gas drilling platforms are not included in this definition.
- (39) "Shipbuilding or ship repair operations" means any building, repair, repainting, converting, or alteration of ships.
- (40) "Solids" means nonvolatiles.
- (41) "Special marking coating" means any coating that is used for safety or identification applications, such as markings on flight decks and ships' numbers.

- (42) "Tack coating" means any thin film epoxy coating applied at a maximum thickness of two dry mils to prepare an epoxy coating that has dried beyond the time limit specified by the manufacturer for the application of the next coat.
- (43) "Thinner" means a liquid that is used to reduce the viscosity of a coating and that evaporates before or during the cure of a film.
- (44) "Thinning ratio" means the volumetric ratio of thinner to coating, as supplied.
- (45) "Thinning solvent" means thinner.
- (46) "Undersea weapons systems coating" means any coating applied to any component of a weapons system intended to be launched or fired from under the sea.
- (47) "USCG" means the United States coast guard.
- (48) "Weld-through preconstruction primer" means a coating that provides corrosion protection for steel during inventory, is typically applied at less than one mil dry film thickness, does not require removal prior to welding, is temperature resistant (burn back from a weld is less than 1.25 centimeters (0.5 inch)), and does not normally require removal before applying film-building coatings, including inorganic zinc high-build coatings. When constructing new vessels, there may be a need to remove areas of weld-through preconstruction primer due to surface damage or contamination prior to application of film-building coatings.

(CC) [Reserved.]

(DD) As used in rule 3745-21-22 of the Administrative Code (pertaining to the control of VOC emissions from lithographic and letterpress printing operations):

- (1) "Alcohol" means any of the following compounds, when used as a fountain solution additive for offset lithographic printing: ethanol, n-propanol, and isopropanol.
- (2) "Alcohol substitutes" means nonalcohol additives that contain VOCs and are used in the fountain solution. Some additives are used to reduce the surface tension of water; others are added to prevent piling (ink build-up).
- (3) "Automatic blanket wash system" means equipment used to clean lithographic blankets which can include, but is not limited to those utilizing a cloth and expandable bladder, brush, spray, or impregnated cloth system.

- (4) "Cleaning material" means with respect to a surface coating operation or graphic arts operation, a liquid solvent or solution used to clean the operating surfaces of a printing press and its parts. For purposes of this standard, cleaning solutions include, but are not limited to blanket wash, roller wash, metering roller cleaner, plate cleaner, impression cylinder washes, rubber rejuvenators, and other cleaners used for cleaning a press, press parts, or to remove dried ink or coating from areas around the press.
- (5) "Capture system" means all equipment, including but not limited to hoods, ducts, fans, ovens and dryers, used to contain, collect, and route VOC vapors released from a coating line or printing line.
- (6) "Control system" means any device or combination of devices designed to recover or incinerate VOC vapors received from a capture system.
- (7) "Composite partial pressure" means the sum of the partial pressures of the VOC compounds in a solvent.
- (8) "Dampening system" means equipment used to deliver the fountain solution to the lithographic plate.
- (9) "Fountain solution" means a mixture of water and other volatile and non-volatile chemicals and additives used in lithographic printing operations that maintains the quality of the printing plate including preventing debris build up (e.g., spray power, paper fiber, coating particles, dried ink particles, and other materials), and increases viscosity and reduces the surface tension of the water so that ~~it~~the solution spreads easily across the printing plate surface. The fountain solution wets the nonimage area so that the ink is maintained within the image areas. Non-volatile additives include mineral salts and hydrophilic gums. Alcohol and alcohol substitutes are the most common VOC additives used to reduce the surface tension of the fountain solution.
- (10) "Fountain solution batch" means a supply of fountain solution that is prepared and used without alteration until completely used or removed from the printing process. For the purposes of this rule, this term may apply to solutions prepared in either discrete batches or solutions that are continuously blended with automatic mixing units.
- (11) "Fountain solution reservoir" means the collection tank that accepts fountain solution recirculated from printing units. In some cases, the tanks are equipped with cooling coils for refrigeration of the fountain solution.

- (12) "Heatset" means a lithographic printing process where the printing inks are set by the evaporation of the ink oils in a heatset dryer.
- (13) "Heatset dryer" means a hot air dryer used in heatset lithography to heat the printed substrate and to promote the evaporation of ink oils.
- (14) "Inking system" means a series of rollers used to meter ink onto the lithographic plate. The system can include agitators, pumps, totes, and other types of ink containers.
- (15) "Lithographic printing" or "lithographic printing operation" means a planographic printing process where the image and nonimage areas are chemically differentiated; the image area is oil receptive and the nonimage area is water receptive. This method differs from other printing methods, where the image is typically printed from a raised or recessed surface. A lithographic printing operation includes, but is not limited to, a heatset web lithographic printing operation, a coldset web offset lithographic printing operation, and a sheet-fed offset lithographic printing operation.
- (16) "Non-heatset lithographic printing" means a lithographic printing process where the printing inks are set by absorption or oxidation of the ink oil, not by evaporation of the ink oils in a dryer. Use of an infrared heater or printing conducted using ultraviolet-cured or electron beam-cured inks is considered non-heatset.
- (17) "Offset lithography" means a printing process that transfers the ink film from the lithographic plate to an intermediary surface (blanket), which, in turn, transfers the ink film to the substrate.
- (18) "Press" means a printing production assembly composed of one or more units used to produce a printed substrate including any associated coating, spray powder application, heatset web dryer, ultraviolet or electron beam curing units, or infrared heating units.
- (19) "Sheet-fed lithographic printing" means a non-heatset lithographic printing process where individual sheets of substrate are fed into the press sequentially.
- (20) "Unit" means the smallest complete printing component, composed of inking and dampening systems, of a printing press.
- (21) "Web" means a lithographic printing process where a continuous roll of substrate is fed into a press.

- (22) "Letterpress printing" means a printing method where the image area is raised relative to the non-image area and the ink is transferred to the paper directly from the image surface.
- (23) "Raoult's Law" means the vapor pressure of the solvent in an ideal solution is equal to the mole fraction of the solvent times the vapor pressure of the pure solvent.
- (EE) As used in rule 3745-21-23 of the Administrative Code (pertaining to the control of VOC emissions from industrial cleaning solvents):
- (1) "Composite partial pressure" means the sum of the partial pressures of the VOC compounds in a solvent.
 - (2) "Digital printing" means a print-on-demand method of printing in which an electronic output device transfers variable data, in the form of an image, from a computer to a variety of substrates. Digital printing methods include, but are not limited to, inkjet printing, electrophotographic printing, dye sublimation printing, thermal wax printing and solid ink printing.
 - (3) "Screen printing" means a process in which the printing ink passes through a web or a fabric to which a refined form of stencil has been applied. The stencil openings determine the form and dimensions of the imprint.
- (FF) As used in rule 3745-21-24 of the Administrative Code (pertaining to the control of VOC emissions from flat wood paneling coatings):
- (1) "Class 2 hardboard paneling finishes" means finishes which meet the specifications of ANSI ~~A135.5-2012~~A135.5.
 - (2) "Flat wood paneling" means a printed interior panel made of hardwood plywood and thin particle board, natural finish hardwood plywood, hardwood paneling, baseboard, wood flat stock, veneers, doors, door skins, wood flat product skins, tileboard and wallboard.
 - (3) "Hardboard" means a panel manufactured primarily from inter-felted ligno-cellulosic fibers which are consolidated under heat and pressure in a hot press.
 - (4) "Hardwood plywood" means a plywood whose surface layer is a veneer of hardwood.
 - (5) "Natural finish hardwood plywood panel" means a panel whose original grain pattern is enhanced by essentially transparent finishes frequently supplemented by fillers and toners.

- (6) "Panel" means a flat piece of wood or wood product usually rectangular and used inside homes and mobile homes for wall decorations.
 - (7) "Printed interior panel" means a panel whose grain or natural surface is obscured by fillers and basecoats upon which a simulated grain or decorative pattern is printed.
 - (8) "Thin particleboard" means a manufactured board one-quarter inch or less in thickness made of individual wood particles which have been coated with a binder and formed into flat sheets by pressure.
 - (9) "Tileboard" means a paneling that has a colored waterproof surface coating.
 - (10) "Wood flat stock" means an interior panel containing wood including but not limited to redwood stocks, plywood panels, particle boards, composition hardboards, and any other panels containing solid wood or wood product.
- (GG) As used in rule 3745-21-25 of the Administrative Code (pertaining to control of VOC emissions from reinforced plastic composites production operations):
- (1) "Add-on control device" means an air pollution control device, such as a thermal oxidizer or carbon adsorber that reduces pollution in an air stream by destruction or removal before discharge to the atmosphere.
 - (2) "AP-42" means the USEPA document "Compilation of Air Pollutant Emissions Factors, Volume I: Stationary Point and Area Sources."
 - (3) "Atomized mechanical application means" application of resin or gel coat with spray equipment that separates the liquid into a fine mist. This fine mist may be created by forcing the liquid under high pressure through an elliptical orifice, bombarding a liquid stream with directed air jets, or a combination of these techniques.
 - (4) "Bulk molding compound" or "BMC" means a putty-like molding compound containing resins in a form that is ready to mold. In addition to resins, BMC may contain catalysts, fillers, and reinforcements. Bulk molding compound can be used in compression molding and injection molding operations to manufacture reinforced plastic composites products.
 - (5) "BMC manufacturing" means a process that involves the preparation of BMC.
 - (6) "Centrifugal casting" means a process for fabricating cylindrical composites, such as pipes, in which composite materials are positioned inside a rotating hollow

mandrel and held in place by centrifugal forces until the part is sufficiently cured to maintain its physical shape.

- (7) "Charge" means the amount of SMC or BMC that is placed into a compression or injection mold necessary to complete one mold cycle.
- (8) "Cleaning" means removal of composite materials, such as cured and uncured resin from equipment, finished surfaces, floors, hands of employees, or any other surfaces.
- (9) "Clear production gel coat" means an unpigmented, quick-setting resin used to improve the surface appearance or performance of composites. The clear production gel coat can be used to form the surface layer of any composites other than those used for molds in tooling operations.
- (10) "Closed molding" means a grouping of processes for fabricating composites in a way that VOC-containing materials are not exposed to the atmosphere except during the material loading stage (e.g., compression molding, injection molding, and resin transfer molding). Processes where the mold is covered with plastic (or equivalent material) prior to resin application, and the resin is injected into the covered mold are also considered closed molding.
- (11) "Composite" means a shaped and cured part produced by using composite materials.
- (12) "Composite materials" means the raw materials used to make composites. The raw materials include styrene-containing resins. Composite materials may also include gel coat, monomer, catalyst, pigment, filler, and reinforcement.
- (13) "Compression molding" means a closed molding process for fabricating composites in which composite materials are placed inside matched dies that are used to cure the materials under heat and pressure without exposure to the atmosphere. The addition of mold paste or in-mold coating is considered part of the closed molding process. The composite materials used in this process are generally SMC or BMC.
- (14) "Compression/injection molding" means a grouping of processes that involves the use of compression molding or injection molding.
- (15) "Continuous casting" means a continuous process for fabricating composites in which composite materials are placed on an in-line conveyor belt to produce cast sheets that are cured in an oven.

- (16) "Continuous lamination" means a continuous process for fabricating composites in which composite materials are typically sandwiched between plastic films, pulled through compaction rollers, and cured in an oven. This process is generally used to produce flat or corrugated products on an in-line conveyor.
- (17) "Continuous lamination/casting" means a grouping of processes that involves the use of continuous lamination or continuous casting.
- (18) "Controlled oven VOC emissions" means VOC emissions emitted to the atmosphere from an oven's control device.
- (19) "Controlled wet-out area VOC emissions" means VOC emissions emitted to the atmosphere from a wet-out area's control device.
- (20) "Corrosion-resistant gel coat" means a gel coat used on a product made with a corrosion-resistant resin that has a corrosion-resistant end-use application.
- (21) "Corrosion-resistant end-use applications" means applications where the product is manufactured specifically for an application that requires a level of chemical inertness or resistance to chemical attack above that required for typical reinforced plastic composites products. These applications include, but are not limited to, chemical processing and storage; pulp and paper production; sewer and wastewater treatment; power generation; potable water transfer and storage; food and drug processing; pollution or odor control; metals production and plating; semiconductor manufacturing; petroleum production, refining, and storage; mining; textile production; nuclear materials storage; swimming pools; and cosmetic production, as well as end-use applications that require high strength resins.
- (22) "Corrosion-resistant industry standard" means any of the following standards: ANSI/ASME ~~RTP-1-2011~~RTP-1; ASME ~~BPVC-X-2013~~BPVC-X; ASTM ~~D5364-08e1~~D5364, ~~D3299-10~~D3299, ~~D4097-01(2010)~~D4097, ~~D2996-01(2007)e1~~D2996, ~~D2997-01(2007)e1~~D2997, ~~D3262-11~~D3262, ~~D3517-11~~D3517, ~~D3754-11~~D3754, ~~D3840-10~~D3840, ~~D4024-12~~D4024, ~~D4161-01(2010)~~D4161, ~~D3982-08~~D3982, or ~~D3839-08~~D3839; ANSI/AWWA ~~C950-07~~C950; UL 2215, 1316 or 1746, IAPMO/ANSI ~~Z1000-2007~~Z1000, or written customer requirements for resistance to specified chemical environments.
- (23) "Corrosion-resistant product" means a product made with a corrosion-resistant resin and is manufactured to a corrosion-resistant industry standard, or a food contact industry standard, or is manufactured for corrosion-resistant end-use applications involving continuous or temporary chemical exposures.

- (24) "Corrosion-resistant resin" means a resin that does either of the following:
- (a) Displays substantial retention of mechanical properties when undergoing ASTM ~~E581-03(2008)~~+C581 coupon testing, where the resin is exposed for six months or more to one of the following materials: material with a pH equal to or greater than 12.0 or a pH less than or equal to 3.0, oxidizing or reducing agents, organic solvents, or fuels or additives as defined in 40 CFR 79.2. In the coupon testing, the exposed resin needs to demonstrate a minimum of fifty per cent retention of the relevant mechanical property compared to the same resin in unexposed condition. In addition, the exposed resin needs to demonstrate an increased retention of the relevant mechanical property of at least twenty percentage points when compared to a similarly exposed general-purpose resin. For example, if the general-purpose resin retains forty-five per cent of the relevant property when tested as specified above, then a corrosion-resistant resin needs to retain at least sixty-five per cent (forty-five per cent plus twenty per cent) of its property. The general-purpose resin used in the test needs to have an average molecular weight of greater than one thousand, be formulated with a one to two ratio of maleic anhydride to phthalic anhydride and one hundred per cent diethylene glycol, and a styrene content between forty-three to forty-eight per cent.
 - (b) Complies with industry standards that require specific exposure testing to corrosive media, such as UL 1316, UL 1746, or ASTM ~~F1216-09~~F1216.
- (25) "CR/HS" means corrosion-resistant and/or high strength.
- (26) "Doctor box" means the box or trough on an SMC machine into which the liquid resin paste is delivered before being metered onto the carrier film.
- (27) "Fiberglass boat" means a vessel in which either the hull or deck is built from a composite material consisting of a thermosetting resin matrix reinforced with fibers of glass, carbon, aramid, or other material.
- (28) "Filament application" means an open molding process for fabricating composites in which reinforcements are fed through a resin bath and wound onto a rotating mandrel. The materials on the mandrel may be rolled out or worked by using nonmechanical tools prior to curing. Resin application to the reinforcement on the mandrel by means other than the resin bath, such as spray guns, pressure-fed rollers, flow coaters, or brushes is not considered filament application.

- (29) "Filled resin" means that fillers have been added to a resin such that the amount of inert substances is at least ten per cent by weight of the total resin plus filler mixture. Filler putty made from a resin is considered a filled resin.
- (30) "Fillers" means inert substances dispersed throughout a resin, such as calcium carbonate, alumina trihydrate, hydrous aluminum silicate, mica, feldspar, wollastonite, silica, and talc. Materials that are not considered to be fillers are glass fibers or any type of reinforcement and microspheres.
- (31) "Fire retardant gel coat" means a gel coat used for low-flame spread/low-smoke products for which resin is used.
- (32) "Fluid impingement technology" means a spray gun that produces an expanding non-misting curtain of liquid by the impingement of low-pressure uninterrupted liquid streams.
- (33) "Food contact industry standard" means a standard related to food contact application contained in food and drug administration's regulations at 21 CFR 177.2420.
- (34) "Gel coat" means a quick-setting resin used to improve surface appearance or performance of composites. The gel coat can be used to form the surface layer of any composites other than those used for molds in tooling operations.
- (35) "Gel coat application" means a process where either clear production, pigmented production, white/off-white or tooling gel coat is applied.
- (36) "High performance gel coat" means a gel coat used on products for which national sanitation foundation, United States department of agriculture, ASTM, durability, or other property testing is required.
- (37) "High strength gel coat" means a gel coat applied to a product that requires high strength resin.
- (38) "High strength resin" means a polyester resin which has a casting tensile strength of ten thousand pounds per square inch or more and which is used for manufacturing products that have high strength requirements such as structural members and utility poles.
- (39) "Injection molding" means a closed molding process for fabricating composites in which composite materials are injected under pressure into a heated mold cavity that represents the exact shape of the product. The composite materials are cured in the heated mold cavity.

- (40) "Low flame spread/low smoke products" means products that meet the following:
- (a) ~~The products shall meet~~ For all products, both the applicable flame spread requirements and the applicable smoke requirements.
 - (b) ~~Interior~~ For interior or exterior building application products, ~~shall meet~~ an ASTM ~~E84-12~~ E84 flame spread index of less than or equal to twenty-five, and smoke developed index of less than or equal to four hundred fifty, or pass national fire protection association 286 room corner burn test with no flash over and total smoke released not exceeding one thousand meters square.
 - (c) ~~Mass~~ For mass transit application products, ~~shall meet~~ an ASTM ~~E162-12a~~ E162 flame spread index of less than or equal to thirty-five and ASTM ~~E662-13~~ E662 smoke density Ds at 1.5 minutes less than or equal to one hundred and Ds at four minutes less than to equal to two hundred.
 - (d) ~~Duct~~ For duct application products, ~~shall meet an~~ ASTM ~~E84-12~~ E84 flame spread index less than or equal to twenty-five and smoke developed index less than or equal to fifty on the interior or exterior of the duct.
- (41) "Manual resin application" means an open molding process for fabricating composites in which composite materials are applied to the mold by pouring or by using hands and nonmechanical tools, such as brushes and rollers. Materials are rolled out or worked by using nonmechanical tools prior to curing. The use of pressure-fed rollers and flow coaters to apply resin is not considered manual resin application.
- (42) "Mechanical resin application" means an open molding process for fabricating composites in which composite materials (except gel coat) are applied to the mold by using mechanical tools such as spray guns, pressure-fed rollers, and flow coaters. Materials are rolled out or worked by using nonmechanical tools prior to curing.
- (43) "Mixing" means the blending or agitation of resin or gel coat in vessels that are 5.00 gallons (18.9 liters) or larger, and includes the mixing of putties or polyputties. Mixing may involve the blending of resin or gel coat with filler, reinforcement, pigments, catalysts, monomers, and any other additives.
- (44) "Mold" means a cavity or matrix into or onto which the composite materials are placed and from which the product takes its form.

- (45) "Monomer" means an organic compound that combines with itself or other similar compounds by a cross-linking reaction to become a part of a cured thermoset resin.
- (46) "Monomer content" means the per cent, by weight, of monomer (styrene, methyl methacrylate, and any other monomer) contained in the resin or gel coat prior to the addition of fillers, catalyst, and promoters.
- (47) "Neat gel coat" means the gel coat as purchased from the supplier, but not including any inert fillers.
- (48) "Neat gel coat plus" means neat gel coat plus any VOC-containing materials that are added to the gel coat by the supplier or the facility, excluding catalysts and promoters. Neat gel coat plus does include any additions of styrene or methyl methacrylate monomer in any form, including in catalysts and promoters.
- (49) "Neat resin" means the resin as purchased from the supplier, but not including any inert fillers.
- (50) "Neat resin plus" means neat resin plus any VOC-containing materials that are added to the resin by the supplier or the facility. Neat resin plus does not include any added filler, reinforcements, catalysts, or promoters. Neat resin plus does include any additions of styrene or methyl methacrylate monomer in any form, including in catalysts and promoters.
- (51) "Nonatomized mechanical application" means the use of application tools other than brushes to apply resin and gel coat where the application tool has documentation provided by its manufacturer or user that this design of the application tool has been VOC emissions tested, and the test results showed that use of this application tool results in VOC emissions that are no greater than the VOC emissions predicted by the applicable nonatomized application equation in table 1 of 40 CFR part 63, subpart WWW. ~~In addition and, the device shall be is~~ operated according to the manufacturer's directions, including instructions to prevent the operation of the device at excessive spray pressures. Examples of nonatomized application include flow coaters, pressure fed rollers, and fluid impingement spray guns.
- (52) "Noncorrosion-resistant resin" means any resin other than a corrosion-resistant resin or a tooling resin.
- (53) "Noncorrosion-resistant product" means any product other than a corrosion-resistant product or a mold.

- (54) "Non-routine manufacture" means that the facility manufactures parts to replace worn or damaged parts of a reinforced plastic composites product, or a product containing reinforced plastic composite parts, that was originally manufactured in another facility. ~~For a part to~~ To qualify as non-routine manufacture, ~~it~~ the part shall be used for repair or replacement, and the manufacturing schedule ~~shall be~~ based on the current or anticipated repair needs of the reinforced plastic composites product, or a product containing reinforced plastic composite parts.
- (55) "Operation" means a specific process typically found at a reinforced plastic composites facility. Examples of operations are noncorrosion-resistant manual resin application, corrosion-resistant mechanical resin application, pigmented gel coat application, mixing and VOC-containing materials storage.
- (56) "Open molding" means a process for fabricating composites in a way that VOC-containing materials are exposed to the atmosphere. Open molding includes processes such as manual resin application, mechanical resin application, filament application, and gel coat application. Open molding also includes application of resins and gel coats to parts that have been removed from the open mold.
- (57) "Pigmented gel coat" means a gel coat that has a color, but does not contain ten per cent of more titanium dioxide by weight. It can be used to form the surface layer of any composites other than those used for molds in tooling operations.
- (58) "Plastic composite" has the same meaning as composite.
- (59) "Polymer casting" means a process for fabricating composites in which composite materials are ejected from a casting machine or poured into an open, partially open, or closed mold and cured. After the composite materials are poured into the mold, they are not rolled out or worked while the mold is open, except for smoothing the material or vibrating the mold to remove bubbles. The composite materials may or may not include reinforcements. Products produced by the polymer casting process include cultured marble products and polymer concrete.
- (60) "Preform injection" means a form of pultrusion where liquid resin is injected to saturate reinforcements in an enclosed system containing one or more chambers with openings only large enough to admit reinforcements. Resin, which drips out of the chamber during the process, is collected in closed piping or covered troughs and then into a covered reservoir for recycle. Resin storage vessels, reservoirs, transfer systems, and collection systems are covered or shielded from the ambient air. Preform injection differs from direct die injection in that the injection chambers are not directly attached to the die.

- (61) "Prepreg materials" means reinforcing fabric received precoated with resin which is usually cured through the addition of heat.
- (62) "PTE" means permanent total enclosure as defined in paragraph (X) of this rule.
- (63) "Pultrusion" means a continuous process for manufacturing composites that have a uniform cross-sectional shape. The process consists of pulling a fiber-reinforcing material through a resin impregnation chamber or bath and through a shaping die, where the resin is subsequently cured. There are several types of pultrusion equipment, such as open bath, resin injection, and direct die injection equipment.
- (64) "Reinforced plastic composites production" means operations in which reinforced or nonreinforced plastic composites or plastic molding compounds are manufactured using thermoset resins or gel coats that contain styrene to produce plastic composites. The resins and gel coats may also contain materials designed to enhance the chemical, physical, or thermal properties of the product. Reinforced plastic composites production also includes cleaning, mixing, VOC-containing materials storage, and repair operations associated with the production of plastic composites.
- (65) "Repair" means application of resin or gel coat to a part to correct a defect, where the resin or gel coat application occurs after the part has gone through all the steps of its typical production process, or the application occurs outside the normal production area. Rerouting a part back through the normal production line, or part of the normal production line, is not considered repair.
- (66) "Resin" means any of a class of organic polymers of natural or synthetic origin used in reinforced plastic composite products to surround and hold fibers, and is solid or semi-solid in the cured state.
- (67) "Resin transfer molding" means a process for manufacturing composites whereby catalyzed resin is transferred or injected into a closed mold in which fiberglass reinforcement has been placed.
- (68) "Sheet molding compound" or "SMC" means a ready-to-mold putty-like molding compound that contains resin processed into sheet form. The molding compound is sandwiched between a top and a bottom film. In addition to resin, the SMC may also contain catalysts, fillers, chemical thickeners, mold release agents, reinforcements, and other ingredients. Sheet molding compound can be used in compression molding to manufacture reinforced plastic composites products.

- (69) "Shrinkage controlled resin" means a resin that when promoted, catalyzed, and filled according to the resin manufacturer's recommendations demonstrates less than 0.3 per cent linear shrinkage when tested according to ASTM D2566-93.
- (70) "SMC manufacturing" means a process which involves the preparation of SMC.
- (71) "Thermoset resin" means a resin that does not become soft or return to a liquid state when heated.
- (72) "Tooling gel coat" means a gel coat that is used to form the surface layer of molds. Tooling gel coats generally have high heat distortion temperatures, low shrinkage, high barcol hardness, and high dimensional stability.
- (73) "Tooling resin" means a resin that is used to produce molds. Tooling resins generally have high heat distortion temperatures, low shrinkage, high barcol hardness, and high dimensional stability.
- (74) "Uncontrolled oven VOC emissions" means those VOC emissions emitted from the oven through closed vent systems to the atmosphere and not to a control device. These VOC emissions do not include VOC emissions that may escape into the workplace through the opening of panels or doors on the ovens or other similar fugitive VOC emissions in the workplace.
- (75) "Uncontrolled wet-out area VOC emissions" means any or all of the following:
- (a) VOC emissions from wet-out areas that do not have any capture and control.
 - (b) VOC emissions that escape from wet-out area enclosures.
 - (c) VOC emissions from wet-out areas that are captured by an enclosure, but are vented to the atmosphere and not to an add-on control device.
- (76) "Unfilled" means that there has been no addition of fillers to a resin or that less than ten per cent of fillers by weight of the total resin plus filler mixture has been added.
- (77) "Vapor suppressant" means an additive, typically a wax, that migrates to the surface of the resin during curing and forms a barrier to seal in the styrene and reduce styrene emissions.
- (78) "Vapor-suppressed resin" means a resin containing a vapor suppressant added for the purpose of reducing styrene emissions during curing.

- (79) "VOC-containing materials storage" means an ancillary process within reinforced plastic composites production that involves keeping VOC-containing materials, such as resins, gel coats, catalysts, monomers, and cleaners, in containers or bulk storage tanks for any length of time. Containers may include small tanks, totes, vessels, and buckets.
- (80) "Wet-out area" means the area within a continuous lamination process or continuous casting process where the resin is applied extending to the point prior to entering the oven.
- (81) "White and off-white gel coat" means a gel coat that contains ten per cent or more titanium dioxide by weight.
- (HH) As used in rule 3745-21-27 of the Administrative Code (pertaining to boat manufacturing operations):
- (1) "Application equipment cleaning" means the process of flushing or removing resins and gel coats from the interior or exterior of equipment that is used to apply resin or gel coat in the manufacture of fiberglass parts.
 - (2) "Atomized application method" means a resin application technology in which the resin leaves the application equipment and breaks into droplets or an aerosol as it travels from the application equipment to the surface of the part. Atomized application methods include, but are not limited to, resin spray guns and resin chopper spray guns.
 - (3) "Boat" means any type of vessel, other than a seaplane, that can be used for transportation on the water.
 - (4) "Boat manufacturing facility" means a facility that manufactures the hulls or decks of boats from fiberglass or builds molds to make fiberglass hulls or decks. A facility that manufactures only parts of boats (such as hatches, seats, or lockers) or boat trailers, but does not manufacture boat hulls, decks or molds for fiberglass boat hulls or decks, is not considered a boat manufacturing facility.
 - (5) "Clear gel coat" means gel coats that are clear or translucent so that underlying colors are visible. Clear gel coats are used to manufacture parts for sale. Clear gel coats do not include tooling gel coats used to build or repair molds.
 - (6) "Closed molding" means any molding process in which pressure is used to distribute the resin through the reinforcing fabric placed between two mold surfaces to either saturate the fabric or fill the mold cavity. The pressure may be clamping pressure, fluid pressure, atmospheric pressure, or vacuum pressure used either alone or in combination. The mold surfaces may be rigid or flexible.

Closed molding includes, but is not limited to, compression molding with sheet molding compound, infusion molding, resin injection molding (RIM), vacuum-assisted resin transfer molding (VARTM), resin transfer molding (RTM), and vacuum-assisted compression molding. Processes in which a closed mold is used only to compact saturated fabric or remove air or excess resin from the fabric (such as in vacuum bagging), are not considered closed molding. Open molding steps, such as application of a gel coat or skin coat layer by conventional open molding prior to a closed molding process, are not closed molding.

- (7) "Cured resin" or "cured gel coat" means resin or gel coat that has changed irreversibly from a liquid to a solid.
- (8) "Fiberglass boat" means a vessel in which either the hull or deck is built from a composite material consisting of a thermosetting resin matrix reinforced with fibers of glass, carbon, aramid, or other material.
- (9) "Fiberglass hull and deck coatings" means coatings applied to the exterior or interior surface of fiberglass boat hulls and decks on the completed boat. Polyester and vinylester resins and gel coats used in building fiberglass parts are not fiberglass hull and deck coatings.
- (10) "Filled resin" or "filled production resin" means a resin to which an inert material has been added to change viscosity, density, shrinkage, or other physical properties.
- (11) "Flowcoater" means a nonatomizing application method of applying resins and gel coats to an open mold with a fluid nozzle in a fan pattern with no air supplied to the nozzle.
- (12) "Gel coat" means a polyester resin surface coating, either pigmented or clear, that provides a cosmetic enhancement and improves resistance to degradation from exposure to the elements.
- (13) "Hand lay-up" means a hand application technique of composite materials using a bucket and a paint brush or a paint roller, or other hand held method of application.
- (14) "Mixing" means any operation in which resin or gel coat, including the mixing of putties or polyputties, is combined with additives that include, but are not limited to, fillers, promoters, or catalysts.
- (15) "Mold" means the cavity or surface into or on which gel coat, resin, and fibers are placed and from which finished fiberglass parts take form.

- (16) "Mold sealing and release agents" means materials applied to a mold to seal, polish, and lubricate the mold to prevent parts from sticking to the mold. Mold sealers, waxes, and glazing and buffing compounds are considered mold sealing and release agents.
- (17) "Monomer" means a relatively low-molecular-weight organic compound such as styrene that combines with itself, or other similar compounds, by a cross-linking reaction to become a cured thermosetting resin.
- (18) "Monomer per cent by weight of a resin" means the weight of the monomer, divided by the weight of the polymer.
- (19) "Nonatomized application method" means any application technology in which the resin is not broken into droplets or an aerosol as it travels from the application equipment to the surface of the part. Nonatomized application methods include, but are not limited to, flowcoaters, chopper flowcoaters, pressure-fed resin rollers, resin impregnators, and hand application (for example, paint brush or paint roller).
- (20) "Open molding resin and gel coat operation" means any process in which the reinforcing fibers and resin are placed in the mold and are open to the surrounding air while the reinforcing fibers are saturated with resin. Open molding includes operations in which a vacuum bag or similar cover is used to compress an uncured laminate to remove air bubbles or excess resin, or to achieve a bond between a core material and a laminate.
- (21) "Pigmented gel coat" means opaque gel coats used to manufacture parts for sale. Pigmented gel coats do not include tooling gel coats used to build or repair molds.
- (22) "Polyester resin materials" means unsaturated polyester resins, such as isophthalic, orthophthalic, halogenated, bisphenol A, vinyl ester, or furan resins; cross-linking agents; catalysts; gel coats; inhibitors; accelerators; promoters; and any other material containing VOC used in polyester resin operations.
- (23) "Polyester resin operations" means fabricate, rework, repair, or touchup products for commercial, military, or industrial use by mixing, pouring, hand laying-up, impregnating, injecting, forming, winding, spraying, or curing by using unsaturated polyester resin materials.
- (24) "Pressure-fed roller" means a fabric roller that is fed with continuous supply of catalyzed resins from a mechanical fluid pump.

- (25) "Production resin" means any resin used to manufacture parts for sale. Production resins do not include tooling resins used to build or repair molds, or assembly adhesives as defined in this rule.
- (26) "Repair" means that portion of the fabrication process that requires the addition of polyester resin materials to portions of a previously fabricated product in order to mend damage.
- (27) "Resin" means any thermosetting resin with or without pigment containing styrene (CAS No. 100-42-5) or methyl methacrylate (CAS No. 80-62-6) and used to encapsulate and bind together reinforcement fibers in the construction of fiberglass parts.
- (28) "Resin impregnator" means a mechanical nonatomizing composite materials application method in which fiber reinforcement is saturated with resins in a controlled ratio for each specific composite product.
- (29) "Roll-out" means the process of using rollers, squeegees, or similar tools to compact reinforcing materials saturated with resin to remove trapped air or excess resin.
- (30) "Skin coat" means a layer of resin and fibers applied over the gel coat to protect the gel coat from being deformed by the next laminate layers.
- (31) "Tooling gel coat" means the gel coat used to build or repair molds (also known as tools) or prototypes (also known as plugs) from which molds will be made.
- (32) "Tooling resin" means the resin used to build or repair molds (also known as tools) or prototypes (also known as plugs) from which molds will be made.
- (33) "Touch-up" means that portion of the process that is necessary to cover minor imperfections.
- (34) "Vacuum bagging" means any molding technique in which the reinforcing fabric is saturated with resin and then covered with a flexible sheet that is sealed to the edge of the mold and where a vacuum is applied under the sheet to compress the laminate, remove excess resin, or remove trapped air from the laminate during curing. Vacuum bagging does not include processes that meet the definition of closed molding.
- (35) "Vinylester resin" means a thermosetting resin containing esters of acrylic or methacrylic acids and having double-bond and ester linkage sites only at the ends of the resin molecules.

(II) As used in rule 3745-21-28 of the Administrative Code (pertaining to miscellaneous industrial adhesives and sealants):

- (1) "Acrylonitrile-butadiene-styrene welding" or "ABS welding" means any process to weld acrylonitrile-butadiene-styrene pipe.
- (2) "Adhesive" means any chemical substance that is applied for the purpose of bonding two surfaces together other than by mechanical means.
- (3) "Adhesive primer" means any product intended by the manufacturer for application to a substrate, prior to the application of an adhesive, to provide a bonding surface.
- (4) "Aerospace component" means the fabricated part, assembly of parts or completed unit of any aircraft, helicopter, missile, or space vehicle, including passenger safety equipment.
- (5) "Aerosol adhesive" means an adhesive packaged as an aerosol product in which the spray mechanism is permanently housed in a non-refillable can designed for handheld application without the need for ancillary hoses or spray equipment.
- (6) "Application process" means a series of one or more adhesive applicators and any associated drying area or oven, or both, wherein an adhesive is applied, dried or cured, or both. An application process ends at the point where the adhesive is dried or cured, or prior to any subsequent application of a different adhesive. The application process does not have to include an oven or flash-off area to be included with this definition.
- (7) "Architectural sealant or sealant primer" means any sealant or sealant primer intended by the manufacturer to be applied to stationary structures, including mobile homes, and their appurtenances. Appurtenances to an architectural structure include, but are not limited to: hand railings, cabinets, bathroom and kitchen fixtures, fences, rain gutters and downspouts, and windows.
- (8) "Automotive glass adhesive primer" means an adhesive primer labeled by the manufacturer to be applied to automotive glass prior to installation of the glass using an adhesive/sealant. This primer improves the adhesion to pinch weld and blocks ultraviolet light.
- (9) "CARB" means the California air resources board.
- (10) "Ceramic tile installation adhesive" means any adhesive intended by the manufacturer for use in the installation of ceramic tiles.

- (11) "Chlorinated polyvinyl chloride plastic" or "CPVC plastic" means a polymer of the vinyl chloride monomer that contains sixty-seven per cent chlorine and is normally identified with a CPVC marking.
- (12) "Chlorinated polyvinyl chloride welding adhesive" or "CPVC welding adhesive" means an adhesive labeled for welding of chlorinated polyvinyl chloride plastic.
- (13) "Cleanup solvent" means a VOC-containing material used to remove a loosely held uncured (i.e., not dry to the touch) adhesive or sealant from a substrate, or clean equipment used in applying a material.
- (14) "Computer diskette jacket manufacturing adhesive" means any adhesive intended by the manufacturer to glue the fold-over flaps to the body of a vinyl computer diskette jacket.
- (15) "Contact bond adhesive" means an adhesive that conforms to the following:
- (a) Is designed for application to both surfaces to be bonded together.
 - (b) Is allowed to dry before the two surfaces are placed in contact with each other.
 - (c) Forms an immediate bond that is impossible, or difficult, to reposition after both adhesive-coated surfaces are placed in contact with each other.
 - (d) Does not need sustained pressure or clamping of surfaces after the adhesive-coated surfaces have been brought together using sufficient momentary pressure to establish full contact between both surfaces.
- Contact adhesive does not include rubber cements that are primarily intended for use on paper substrates. Contact adhesive also does not include vulcanizing fluids that are designed and labeled for tire repair only.
- (16) "Cove base" means a flooring trim unit, generally made of vinyl or rubber, having a concave radius on one edge and a convex radius on the opposite edge that is used in forming a junction between the bottom wall course and the floor or to form an inside corner.
- (17) "Cove base installation adhesive" means any adhesive intended by the manufacturer to be used for the installation of cove base or wall base on a wall or vertical surface at floor level.
- (18) "Cyanoacrylate adhesive" means any adhesive with a cyanoacrylate content of at least ninety-five per cent by weight.

- (19) "Digital printing" means a print-on-demand method of printing in which an electronic output device transfers variable data, in the form of an image, from a computer to a variety of substrates. Digital printing methods include, but are not limited to, inkjet printing, electrophotographic printing, dye sublimation printing, thermal wax printing and solid ink printing.
- (20) "Flexible vinyl" means non-rigid polyvinyl chloride plastic with at five per cent by weight plasticizer content.
- (21) "Fiberglass" means a material consisting of extremely fine glass fibers.
- (22) "Indoor floor covering installation adhesive" means any adhesive intended by the manufacturer for use in the installation of wood flooring, carpet, resilient tile, vinyl tile, vinyl backed carpet, resilient sheet and roll, or artificial grass. Adhesives used to install ceramic tile and perimeter bonded sheet flooring with vinyl backing onto a non-porous substrate, such as flexible vinyl, are excluded from this definition.
- (23) "Laminate" means a product made by bonding together two or more layers of material.
- (24) "Marine deck sealant" or "marine deck sealant primer" means any sealant or sealant primer labeled for application to wooden marine decks.
- (25) "Medical equipment manufacturing" means the manufacture of medical devices, such as, but not limited to, catheters, heart valves, blood cardioplegia machines, tracheostomy tubes, blood oxygenators, and cardiatory reservoirs.
- (26) "Metal to urethane/rubber molding or casting adhesive" means any adhesive intended by the manufacturer to bond metal to high density or elastomeric urethane or molded rubber materials, in heater molding or casting processes, to fabricate products such as rollers for computer printers or other paper handling equipment.
- (27) "Motor vehicle adhesive" means an adhesive, including glass bonding adhesive, used at a facility that is not an automobile or light-duty truck assembly coating facility, applied for the purpose of bonding two vehicle surfaces together without regard to the substrates involved.
- ~~(27)~~(28) "Multipurpose construction adhesive" means any adhesive intended by the manufacturer for use in the installation or repair of various construction materials including but not limited to drywall subfloor, panel, fiberglass reinforced plastic, ceiling tile and acoustical tile.

- ~~(28)~~(29) "Non-membrane roof installation/repair adhesive" means any adhesive intended by the manufacturer for use in the installation or repair of nonmembrane roofs and that is not intended for the installation of prefabricated single-ply flexible roofing membrane, including but not limited to plastic or asphalt roof cement, asphalt roof coating and cold application cement.
- ~~(29)~~(30) "Outdoor floor covering installation adhesive" means any adhesive intended by the manufacturer for use in the installation of floor covering that is not in an enclosure and that is exposed to ambient weather conditions during normal use.
- ~~(30)~~(31) "Panel installation" means the installation of plywood, pre-decorated hardboard (or tileboard), fiberglass reinforced plastic, and similar pre-decorated or non-decorated panels to studs or solid surfaces using an adhesive formulated for that purpose.
- ~~(31)~~(32) "Perimeter bonded sheet flooring installation" means the installation of sheet flooring with vinyl backing onto a nonporous substrate using an adhesive designed to be applied only to a strip of up to four inches wide around the perimeter of the sheet flooring.
- ~~(32)~~(33) "Plastic cement welding adhesive" means any adhesive intended by the manufacturer for use to dissolve the surface of plastic to form a bond between mating surfaces.
- ~~(33)~~(34) "Plastic cement welding adhesive primer" means any primer intended by the manufacturer for use to prepare plastic substrates prior to bonding or welding.
- ~~(34)~~(35) "Plastic foam" means foam constructed of plastics.
- ~~(35)~~(36) "Plastics" means synthetic materials chemically formed by the polymerization of organic (carbon-based) substances. Plastics are usually compounded with modifiers, extenders, or reinforcers and are capable of being molded, extruded, cast into various shapes and films or drawn into filaments.
- ~~(36)~~(37) "Polyvinyl chloride plastic" or "PVC plastic" means a polymer of the chlorinated vinyl monomer that contains fifty-seven per cent chlorine.
- ~~(37)~~(38) "Polyvinyl chloride welding adhesive" or "PVC welding adhesive" means any adhesive intended by the manufacturer for use in the welding of PVC plastic pipe.
- ~~(38)~~(39) "Porous material" means a substance that has tiny openings, often microscopic, in which fluids may be absorbed or discharged, including but not limited to, wood, paper and corrugated paperboard.

- ~~(39)~~(40) "Reactive diluent" means a liquid that is a reactive organic compound during application and one in that, through chemical or physical reactions, such as polymerization, twenty per cent or more of the reactive organic compound becomes an integral part of a finished material.
- ~~(40)~~(41) "Roadway sealant" means any sealant intended by the manufacturer for application to public streets, highways and other surfaces, including but not limited to curbs, berms, driveways and parking lots.
- ~~(41)~~(42) "Rubber" means any natural or manmade rubber substrate, including but not limited to, styrene-butadiene rubber, polychloroprene (neoprene), butyl rubber, nitrile rubber, chlorosulfonated polyethylene and ethylene propylene diene terpolymer.
- ~~(42)~~(43) "SCAQMD" means the south coast air quality management district, a part of the California air resources board, which is responsible for the regulation of air quality in the state of California.
- ~~(43)~~(44) "Sealant primer" means any product intended by the manufacturer for application to a substrate, prior to the application of a sealant, to enhance the bonding surface.
- ~~(44)~~(45) "Sealant" means any material with adhesive properties that is formulated primarily to fill, seal, waterproof or weatherproof gaps or joints between two surfaces. Sealants include sealant primers and caulks.
- ~~(45)~~(46) "Sheet-applied rubber installation" means the process of applying sheet rubber liners by hand to metal or plastic substrates to protect the underlying substrate from corrosion or abrasion. These operations also include laminating sheet rubber to fabric by hand.
- ~~(46)~~(47) "Single-ply roof membrane" means a prefabricated single sheet of rubber, normally ethylene-propylenediene terpolymer, that is field applied to a building roof using one layer of membrane material.
- ~~(47)~~(48) "Single-ply roof membrane installation/repair adhesive" means any adhesive labeled for use in the installation or repair of single-ply roof membrane. Installation includes, as a minimum, attaching the edge of the membrane to the edge of the roof and applying flashings to vents, pipes and ducts that protrude through the membrane. Repair includes gluing the edges of torn membrane together, attaching a patch over a hole and reapplying flashings to vents, pipes or ducts installed through the membrane.

- ~~(48)~~(49) "Single-ply roof membrane adhesive primer" means any primer labeled for use to clean and promote adhesion of the single-ply roof membrane seams or splices prior to bonding.
- ~~(49)~~(50) "Single-ply roof membrane sealant" means any sealant labeled for application to single-ply roof membrane.
- ~~(50)~~(51) "Solvent" means organic compounds that are used as diluents, thinners, dissolvers, viscosity reducers, cleaning agents or other related uses.
- ~~(51)~~(52) "Structural glazing adhesive" means any adhesive intended by the manufacturer to apply glass, ceramic, metal, stone or composite panels to exterior building frames.
- ~~(52)~~(53) "Subfloor installation" means the installation of subflooring material over floor joists, including the construction of any load bearing joists. Subflooring is covered by a finish surface material.
- ~~(53)~~(54) "Surface preparation solvent" means a solvent used to remove dirt, oil and other contaminants from a substrate prior to the application of a primer, adhesive or sealant.
- ~~(54)~~(55) "Thin metal laminating adhesive" means any adhesive intended by the manufacturer for use in bonding multiple layers of metal to metal or metal to plastic in the production of electronic or magnetic components in which the thickness of the bond line is less than 0.25 millimeters.
- ~~(55)~~(56) "Tire repair" means a process that includes expanding a hole, tear, fissure or blemish in a tire casing by grinding or gouging, applying adhesive and filling the hole or crevice with rubber.
- ~~(56)~~(57) "Tire tread adhesive" means any adhesive intended by the manufacturer for application to the back of precure tread rubber and to the casing and cushion rubber. Tire tread adhesive may also be used to seal buffed tire casings to prevent oxidation while the tire is being prepared for a new tread.
- ~~(57)~~(58) "Traffic marking tape" means preformed reflective film intended by the manufacturer for application to public streets, highways and other surfaces, including but not limited to curbs, berms, driveways and parking lots.
- ~~(58)~~(59) "Traffic marking tape adhesive primer" means any primer intended by the manufacturer for application to surfaces prior to installation of traffic marking tape.

~~(59)~~(60) "Undersea-based weapons systems components" means the fabrication of parts, assembly of parts or completed units of any portion of a missile launching system used on undersea ships.

~~(60)~~(61) "Waterproof resorcinol glue" means a two-part resorcinol-resin-based adhesive designed for applications where the bond line must be resistant to conditions of continuous immersion in fresh or salt water.

(JJ) Referenced materials. This chapter includes references to certain matter or materials. The text of the referenced materials is not included in the rules contained in this chapter. Information on the availability of the referenced materials as well as the date of, or the particular edition or version of the material is included in this rule. For materials subject to change, only the specific versions specified in this rule are referenced. Material is referenced as it exists on the effective date of this rule. Except for subsequent annual publication of existing (unmodified) Code of Federal Regulation compilations, any amendment or revision to a referenced document is not applicable unless and until this rule has been amended to specify the new dates.

(1) Availability. The referenced materials are available as follows:

- (a) "American Architectural Manufacturers Association" (AAMA). Information and copies of documents may be obtained by writing to: "AAMA, 1827 Walden Office Square, Suite 550, Schaumburg, IL 60173." These documents are also available for purchase at www.aamanet.org. AAMA documents are also available for inspection and copying use at most public libraries and "The State Library of Ohio."
- (b) "American National Standards Institute" (ANSI). Information and copies of publications may be obtained by writing to: "ANSI, Attn: Customer Service Department, 25 W 43rd Street, 4th Floor, New York, NY, 10036." Publications are also available for ordering at <http://webstore.ansi.org>. The ANSI publications are also available for inspection and copying use at most public libraries and "The State Library of Ohio."
- (c) "American Petroleum Institute" (API). Information and copies of publications may be obtained by writing to: "Techstreet, 3916 Ranchero dr., Ann Arbor, MI, USA 48108." Publications are also available for ordering at <http://www.techstreet.com/apigate.html>. The API publications are also available for inspection and copying use at most public libraries and "The State Library of Ohio."
- (d) "American Society for Testing Materials" (ASTM). Information and copies of documents may be obtained by writing to: "ASTM International, 100

Bar Harbor Drive, P.O. Box C700, West Conshohocken, Pennsylvania 19426-2959." These documents are also available for purchase at www.astm.org. ASTM documents are also available for inspection and copying use at most public libraries and "The State Library of Ohio."

- (e) "American Society of Mechanical Engineers" (ASME). Information and copies of documents may be obtained by writing to: "ASME, Two Park Avenue, New York, NY 10016-5990." These documents are also available for purchase at www.asme.org. ASME documents are also available for inspection and copying use at most public libraries and "The State Library of Ohio."
- (f) "American Water Works Association" (AWWA). Information and copies of documents may be obtained by writing to: "AWWA, 6666 W. Quincy Ave., Denver, CO 80235." These documents are also available for purchase at www.awwa.org. AWWA documents are also available for inspection and copying use at most public libraries and "The State Library of Ohio."
- (g) "California air resources board (CARB) certification". Information and copies of executive orders, approval letters, equipment advisories, certification procedures and equivalent test procedures may be obtained by writing to: "California Air Resources Board, Monitoring and Laboratory Division, P.O. Box 2815, Sacramento, CA, 95812-2815" or by calling (916) 327-0900. The full text of all CARB certification documents are also available in electronic format at <http://www.arb.ca.gov/vapor/vapor.htm>.
- (h) "California Code of Regulations." Copies of regulations may be obtained by writing to: " West Customer Service, P.O. Box 64833, St. Paul, MN 55164-0833" or by calling 1-800-888-3600. The full text of regulations are also available in electronic format at <http://ccr.oal.ca.gov/>.
- (i) Chemical abstract service (CAS). Information can be obtained by writing to: "Chemical Abstract Service, 2540 Olentangy River road, Columbus, Ohio, 43202," or by visiting the web site at www.cas.org.
- (j) Clean Air Act. Information and copies may be obtained by writing to: "U.S. government printing office, P.O. Box 979050, St. Louis, MO 63197-9000." The full text of the Act as amended in 1990 is also available in electronic format at www.epa.gov/oar/caa/. A copy of the Act is also available for inspection and copying use at most public libraries and "The State Library of Ohio."

- (k) "Code of Federal Regulations" (CFR). Information and copies may be obtained by writing to: "U.S. government printing office, P.O. Box 979050, St. Louis, MO 63197-9000." The full text of the CFR is also available in electronic format at www.ecfr.gov/. The CFR compilations are also available for inspection and copying use at most public libraries and "The State Library of Ohio."
- (l) "Compilation of Air Pollutant Emission Factors, Volume I: Stationary Point and Area Sources" (AP-42). Information and copies may be obtained by writing to: "U.S. Government Printing Office, P.O. Box 979050, St. Louis, MO 63197-9000." The full text of AP-42 is also available in electronic format at <http://www.epa.gov/ttn/chief/ap42/index.html>. AP-42 is also available for inspection and copying use at most public libraries and "The State Library of Ohio."
- (m) "Control of Volatile Organic Compound Emissions from Coating Operations at Aerospace Manufacturing and Rework Operations." Information and copies may be obtained by writing to: "U.S. EPA/NSCEP, P.O. Box 42419, Cincinnati, Ohio 45242-0419." This document is also available for ordering at <http://www.epa.gov/nscep/?OpenForm>. A copy of ~~the~~ this document is also available for inspection and copying use at most public libraries and "The State Library of Ohio."
- (n) "Control of Volatile Organic Compound Emissions from Reactor Processes and Distillation Operations Processes in the Synthetic Organic Chemical Manufacturing Industry." Information and copies may be obtained by writing to: "U.S. EPA/NSCEP, P.O. Box 42419, Cincinnati, Ohio 45242-0419." This document is also available for ordering at <http://www.epa.gov/nscep/?OpenForm>. A copy of ~~the~~ this document is also available for inspection and copying use at most public libraries and "The State Library of Ohio."
- (o) "CRC Handbook of Chemistry and Physics." Information and copies may be ordered by writing to: "CRC Press, 6000 Broken Sound Parkway NW, Suite 300, Boca Raton, FL 33487" or by calling (800) 272-7737. A copy of the document is also available for inspection and copying use at most public libraries and "The State Library of Ohio."
- (p) "Federal Insecticide, Fungicide, and Rodenticide Act." Information and copies may be obtained by writing to: "U.S. Government Printing Office, P.O. Box 979050, St. Louis, MO 63197-9000." The full text of the Act is also available in electronic format at <http://www.epa.gov/oecaagct/>

lfra.html. A copy of the Act is also available for inspection and copying use at most public libraries and "The State Library of Ohio."

(q) "Federal Register" (FR). Information and copies may be obtained by writing to: "Superintendent of Documents, Attn: New Orders, P.O. Box 371954, Pittsburgh, PA 15250-7954." Online access to the Federal Register is available at <https://www.federalregister.gov/>. A copy of the Federal Register is also available for inspection and copying use at most public libraries and "The State Library of Ohio."

~~(r) "Guidance for estimating capital and annual costs of air pollution systems (engineering guide 46)." Information and copies may be ordered by writing to the Ohio EPA at: "50 West Town St., Suite 700, Columbus, Ohio, 43215". This document is also available in electronic format at <http://www.epa.ohio.gov/dape/engineer/eguides.aspx>. A copy of the document is also available for inspection and copying at most public libraries and "The State Library of Ohio."~~

~~(s)~~(r) "Guidelines for determining capture efficiency." Information and copies may be obtained by writing to: "Office of Air Quality Planning and Standards (OAQPS), TTN EMCwebmaster, Mail Code E143-02, Research Triangle Park, NC, 27711." This document is also available in electronic format at <http://www.epa.gov/ttn/emc/guidlnd/gd-035.pdf>. A copy of the document is also available for inspection and copying use at most public libraries and "The State Library of Ohio."

~~(t)~~(s) "International Association of Plumbing and Mechanical Officials" (IAPMO). Information and copies of documents may be obtained by writing to: "IAPMO, 4755 East Philadelphia Street, Ontario, California 91761-2816." These documents are also available for purchase at www.iapmo.org. IAPMO documents are also available for inspection and copying use at most public libraries and "The State Library of Ohio."

~~(u)~~(t) "Lange's Handbook of Chemistry." Information and copies may be ordered by writing to: "McGraw-Hill, 860 Taylor Station Road, Blacklick, OH 43004" or by calling (877) 833-5524. A copy of the document is also available for inspection and copying use at most public libraries and "The State Library of Ohio."

~~(v)~~(u) "Methods and Guidance for Analysis of Water." Information and copies may be ordered by writing to: "National Technical Information Service, 5301 Shawnee Road, Alexandria, Virginia, 22312." or by calling 703-605-6000. This document is also available

for ordering at ~~http://www.ntis.gov/products/epa-water-methods.aspx~~ <https://www.epa.gov/nscep>. A copy of the document is also available for inspection and copying use at most public libraries and "The State Library of Ohio".

~~(w)~~(v) "MIL-A-87721" and "MIL-STD-1330C(SH)." Information and copies may be ordered by writing to: "DLA Land and Maritime Freedom of Information Act Office, 3990 E. Broad Street, Columbus, Ohio 43218-3990." These documents are also available in electronic format at <http://www.everyspec.com/library.php>.

~~(x)~~(w) "Motor Vehicle Safety Standards." Information and copies may be obtained by writing to: "NHTSA Headquarters, 1200 New Jersey Avenue, SE, West Building, Washington, DC 20590." These documents are also available in electronic format at <http://www.nhtsa.gov/Laws-Regs>. A copy of the documents are also available for inspection and copying use at most public libraries and "The State Library of Ohio."

~~(y)~~(x) "National Fire Protection Association" (NFPA). Information on the National Fire Protection Association codes may be obtained by contacting the association at "NFPA, 1 Batterymarch Park, Quincy, MA 02169-7471" or by calling 617-770-3000. Codes may be ordered on line at ~~http://www.nfpa.org/categoryList.asp?categoryID=124&URL=Codes%20&%20Standards~~ <https://www.nfpa.org/>. Copies of the code are available at most public libraries and "The State Library of Ohio."

~~(z)~~(y) "Perry's Chemical Engineer's Handbook." Information and copies may be ordered by writing to: "McGraw-Hill, 860 Taylor Station Road, Blacklick, OH 43004" or by calling (877) 833-5524. A copy of the document is also available for inspection and copying use at most public libraries and "The State Library of Ohio."

~~(aa)~~(z) "Petroleum Equipment Institute (PEI)". Information and copies of documents may be obtained by writing to "P.O. Box 2380, Tulsa, OK 74101-2380 or 6514 E. 69 Street, Tulsa, OK 74133-1729", by calling 918-494-9696 (telephone), 918-491-9895 (fax) or electronically on their website at: <http://www.pei.org/>. This document is also available for review and copying use at most public libraries and "The State Library of Ohio."

~~(bb)~~(aa) "Protocol for Determining the Daily Volatile Organic Compound Emission Rate of Automobile and Light-Duty Truck Topcoat Operations." EPA-453/R-08-002 Information and copies may be

ordered by writing to: "State and Local Programs Group, US EPA Mail Code C539-01, Research Triangle Park, NC 27711" or by calling 919-541-5208. A copy of this protocol is also available electronically at: http://www.epa.gov/glo/SIPToolkit/ctg_act/200809_voc_epa453_r-08-002_auto_ldtruck_vocemisrate_protocol.pdf https://www3.epa.gov/airquality/ctg_act/200809_voc_epa453_r-08-002_auto_ldtruck_vocemisrate_protocol.pdf. A copy of the document is also available for inspection and copying use at most public libraries and "The State Library of Ohio."

~~(ee)~~(bb) "Regulatory Guide 1.54 - Service Level I, II and III Protective Coatings Applied to Nuclear Plants." Information and copies may be obtained by writing to: "U.S. Nuclear Regulatory Commission, Washington, DC 20555-0001" or by calling (301)415-7000. A copy of this guide is also available in electronic format at: <http://www.nrc.gov/reading-rm/doc-collections/reg-guides/power-reactors/rg/division-1/division-1-41.html>. A copy of the manual is also available for inspection and copying use at most public libraries and "The State Library of Ohio."

~~(dd)~~(cc) "South Coast Air Quality Management District (SCAQMD) Test Methods." Information and copies of documents may be obtained by writing to: "South Coast AQMD, Public Records Coordinator/Public Records Unit, 21865 Copley Dr., Diamond Bar, CA, 91765." These documents are also available at <http://www.aqmd.gov/tao/methods/labmethhoe.html> <https://www.aqmd.gov/home/research/methods-procedures>. SCAQMD documents are also available for inspection and copying use at most public libraries and "The State Library of Ohio."

~~(ee)~~(dd) "Standard Industrial Classification Manual" (SICM). Information and copies may be ordered by writing to: "U.S. Department of Commerce, Technology Administration, National Technical Information Service, Springfield, Virginia, 22161." or by calling 1-800-553-6847. This document is also available in electronic format at http://www.osha.gov/pls/imis/sic_manual.html. A copy of the manual is also available for inspection and copying use at most public libraries and "The State Library of Ohio."

~~(ff)~~(ee) "Standard Methods for the Examination of Water and Wastewater." Information and copies may be ordered by writing to: "Water Environment Federation, 601 Wythe Street, Alexandria, VA 22314-1994" or by calling 571-830-1545. This document is also

available for ordering at <http://www.standardmethods.org/> or <https://www.e-wef.org/Default.aspx?TabId=192&ProductId=17997>. A copy of the document is also available for inspection and ~~copying~~ use at most public libraries and "The State Library of Ohio."

~~(gg)~~(ff) "SW-846 Test Methods for Evaluating Solid Waste, Physical/Chemical Methods." Information and copies may be obtained by writing to: "National Technical Information Service, 5301 Shawnee Rd., Alexandria, VA 22312." These documents are also available in electronic format at <http://www.epa.gov/epaoswer/hazwaste/test/main.htm> <https://www.epa.gov/hw-sw846>. SW-846 methods are also available for inspection and ~~copying~~ use at most public libraries and "The State Library of Ohio."

~~(hh)~~(gg) "Underwriters Laboratories" (UL). Information and copies of documents may be obtained by writing to: "UL, 2600 N.W. Lake Rd., Camas, WA 98607-8542." These documents are also available for purchase at www.ul.com. UL documents are also available for inspection and ~~copying~~ use at most public libraries and "The State Library of Ohio."

~~(ii)~~(hh) USEPA-approved alternative test methods. Information and copies may be obtained by writing to: "USEPA Office of Air Quality Planning and Standards (OAQPS), TTN EMC Webmaster, Mail Code E143-02, Research Triangle Park, NC 27711." These documents are also available in electronic format at <http://www.epa.gov/ttnemc01/approalt.html> <https://www.epa.gov/emc>. Alternative test methods are also available for inspection and ~~copying~~ use at most public libraries and "The State Library of Ohio."

~~(jj)~~(ii) USEPA conditional test method. Information and copies may be obtained by writing to: "USEPA Office of Air Quality Planning and Standards (OAQPS), TTN EMC Webmaster, Mail Code E143-02, Research Triangle Park, NC 27711." These documents are also available in electronic format at <http://www.epa.gov/ttn/emc/ctm.html> <http://www.epa.gov/ttn/emc/ctm.html>. Conditional test methods are also available for inspection and ~~copying~~ use at most public libraries and "The State Library of Ohio."

~~(kk)~~(jj) "WATER9" is a Windows based computer wastewater treatment model. A copy of the program can be obtained by writing to: "US EPA Office of Air Quality Planning and Standards (OAQPS), Info CHIEF Help Desk, Mail Code D243-05, Research Triangle Park, NC 27711."

This model is also available for downloading at <http://www.epa.gov/ttn/chief/efpac/esttools.html> <https://www.epa.gov/chief>.

(2) Referenced materials.

- (a) 29 CFR 1926, subpart F; "Fire Protection and Prevention"; as published in the July 1, ~~2014~~ 2021 Code of Federal Regulations.
- (b) 40 CFR 51.100; "Definitions"; as published in the July 1, ~~2014~~ 2021 Code of Federal Regulations.
- (c) 40 CFR 60.8; "Performance tests"; as published in the July 1, ~~2014~~ 2021 Code of Federal Regulations.
- (d) 40 CFR 60.13; "Monitoring requirements"; as published in the July 1, ~~2014~~ 2021 Code of Federal Regulations.
- (e) 40 CFR 60.18; "General control device requirements"; as published in the July 1, ~~2014~~ 2021 Code of Federal Regulations.
- (f) 40 CFR 60.485; "Test methods and procedures"; as published in the July 1, ~~2014~~ 2021 Code of Federal Regulations.
- (g) 40 CFR 60.503; "Test methods and procedures"; ~~54 FR 6678, Feb. 14, 1989; 54 FR 21344, Feb. 14, 1989, as amended at 68 FR 70965, Dec. 19, 2003~~ as published in the July 1, 2021 Code of Federal Regulations.
- (h) 40 CFR 63.115; "Process vent provisions--methods and procedures for process vent group determination"; ~~59 FR 19468, Apr. 22, 1994, as amended at 62 FR 2746, Jan. 17, 1997; 66 FR 6931, Jan. 22, 2001~~ as published in the July 1, 2021 Code of Federal Regulations.
- (i) 40 CFR 63.134; "Process wastewater provisions--surface impoundments"; ~~62 FR 2754, Jan. 17, 1997, as amended at 64 FR 20191, Apr. 26, 1999~~ as published in the July 1, 2021 Code of Federal Regulations.
- (j) 40 CFR 63.750; "Test methods and procedures"; ~~60 FR 45956, Sept. 1, 1996, as amended at 63 FR 15021, Mar. 27, 1998; 63 FR 46534, Sept. 1, 1998; 65 FR 62215, Oct. 17, 2000~~ as published in the July 1, 2021 Code of Federal Regulations.
- (k) 40 CFR 63.801; "National Emission Standards for Wood Furniture Manufacturing Operations, Definitions"; as published in the July 1, ~~2014~~ 2021 Code of Federal Regulations.

- (l) 40 CFR 63.803; "National Emission Standards for Wood Furniture Manufacturing Operations, Work practice standards"; as published in the July 1, ~~2014~~ 2021 Code of Federal Regulations.
- (m) 40 CFR 63.3165; "How do I determine the emission capture system efficiency?"; as published in the July 1, ~~2014~~ 2021 Code of Federal Regulations.
- (n) 40 CFR 63.3166; "How do I determine the add-on control device emission destruction or removal efficiency?"; as published in the July 1, ~~2014~~ 2021 Code of Federal Regulations.
- (o) 40 CFR 63.3167; "How do I establish the add-on control device operating limits during the performance test?"; as published in the July 1, ~~2014~~ 2021 Code of Federal Regulations.
- (p) 40 CFR 63.3168; "What are the requirements for continuous parameter monitoring system installation, operation, and maintenance?"; as published in the July 1, ~~2014~~ 2021 Code of Federal Regulations.
- (q) 40 CFR 79.2; "Definitions"; as published in the July 1, ~~2014~~ 2021 Code of Federal Regulations.
- (r) 40 CFR 82.4; "Prohibitions for class I controlled substances"; as published in the July 1, ~~2014~~ 2021 Code of Federal Regulations.
- (s) 40 CFR 264.228; "Closure and post-closure care"; ~~47 FR 32357, July 26, 1982, as amended at 50 FR 28748, July 15, 1985; 57 FR 3488, Jan. 29, 1992~~ as published in the July 1, 2021 Code of Federal Regulations.
- (t) 40 CFR 268.4; "Treatment surface impoundment exemption"; as published in the July 1, ~~2014~~ 2021 Code of Federal Regulations.
- (u) 40 CFR part 50, appendix C; "Measurement Principle and Calibration Procedure for the Measurement of Carbon Monoxide in the Atmosphere (Non-Dispersive Infrared Photometry)"; as published in the July 1, ~~2014~~ 2021 Code of Federal Regulations.
- (v) 40 CFR part 50, appendix D; "Measurement Principle and Calibration Procedure for the Measurement of Ozone in the Atmosphere"; ~~44 FR 8224, Feb. 8, 1979, as amended at 62 FR 38895, July 18, 1997~~ as published in the July 1, 2021 Code of Federal Regulations.

- (w) 40 CFR part 50, appendix H; "Interpretation of the 1-Hour Primary and Secondary National Ambient Air Quality Standards for Ozone"; ~~44 FR 8220, Feb. 8, 1979, as amended at 62 FR 38895, July 18, 1997~~ as published in the July 1, 2021 Code of Federal Regulations.
- (x) 40 CFR part 50, appendix I; "Interpretation of the 8-Hour Primary and Secondary National Ambient Air Quality Standards for Ozone"; ~~62 FR 38895, July 18, 1997~~ as published in the July 1, 2021 Code of Federal Regulations.
- (y) 40 CFR part 53; "Ambient Air Monitoring Reference and Equivalent Methods"; as published in the July 1, ~~2014~~ 2021 Code of Federal Regulations.
- (z) 40 CFR part 60, appendix A; "Standards of Performance for New Stationary Sources"; as published in the July 1, ~~2014~~ 2021 Code of Federal Regulations.
- (aa) 40 CFR part 60, appendix J; ~~proposed December 9, 1998; 63 FR 67988~~ as published in the July 1, 2021 Code of Federal Regulations.
- (bb) 40 CFR part 60, subpart GG; "Standards of Performance for Stationary Gas Turbines"; as published in the July 1, ~~2014~~ 2021 Code of Federal Regulations.
- (cc) 40 CFR part 60, subpart VV; "Standards of Performance for Equipment Leaks of VOC in the Synthetic Organic Chemicals Manufacturing Industry for which Construction, Reconstruction, or Modification Commenced After January 5, 1981, and on or Before November 7, 2006"; as published in the July 1, ~~2014~~ 2021 Code of Federal Regulations.
- (dd) 40 CFR part 60, subpart VVa; "Standards of Performance for Equipment Leaks of VOC in the Synthetic Organic Chemicals Manufacturing Industry for Which Construction, Reconstruction, or Modification Commenced After November 7, 2006"; as published in the July 1, ~~2014~~ 2021 Code of Federal Regulations.
- (ee) 40 CFR part 60, subpart BBB; "Standards of Performance for the Rubber Tire Manufacturing Industry"; ~~52 FR 34874, Sept. 15, 1987, as amended at 52 FR 37874, Oct. 9, 1987; 54 FR 38635-38638, Sept. 19, 1989; 65 FR 61764 to 61765, Oct. 17, 2000~~ as published in the July 1, 2021 Code of Federal Regulations.

- (ff) 40 CFR part 60, subpart GGG; "Standards of Performance for Equipment Leaks of VOC in Petroleum Refineries for which Construction, Reconstruction, or Modification Commenced After January 4, 1983, and on or Before November 7, 2006"; as published in the July 1, ~~2014~~ 2021 Code of Federal Regulations.
- (gg) 40 CFR part 60, subpart GGGa; "Standards of Performance for Equipment Leaks of VOC in Petroleum Refineries for Which Construction, Reconstruction, or Modification Commenced After November 7, 2006"; as published in the July 1, ~~2014~~ 2021 Code of Federal Regulations.
- (hh) 40 CFR part 60, subpart III; "Standards of Performance for New Stationary Sources, Standards of Performance for Volatile Organic Compound (VOC) Emissions From the Synthetic Organic Chemical Manufacturing Industry (SOCMI) Air Oxidation Unit Processes"; ~~55 FR 26922, June 29, 1990; as amended at 55 FR 36932, Sept. 7, 1990; 65 FR 61769 to 61773, Oct. 17, 2000; 65 FR 78278, Dec. 14, 2000~~ as published in the July 1, 2021 Code of Federal Regulations.
- (ii) 40 CFR part 60, subpart NNN; "Standards of Performance for New Stationary Sources, Standards of Performance for Volatile Organic Compound (VOC) Emissions From Synthetic Organic Chemical Manufacturing Industry (SOCMI) Distillation Operations"; ~~55 FR 26922 to 26942, June 29, 1990 as amended at: 55 FR 36932, Sept. 7, 1990; 60 FR 58237, Nov. 27, 1995; 65 FR 61774 to 61778, Oct. 17, 2000; 65 FR 78279, Dec. 14, 2000~~ as published in the July 1, 2021 Code of Federal Regulations.
- (jj) 40 CFR part 60, subpart QQQ; "Standards of Performance for VOC Emissions From Petroleum Refinery Wastewater Systems"; as published in the July 1, ~~2014~~ 2021 Code of Federal Regulations.
- (kk) 40 CFR part 60, subpart RRR; "Standards of Performance for New Stationary Sources, Standards of Performance for Volatile Organic Compound Emissions From Synthetic Organic Chemical Manufacturing Industry (SOCMI) Reactor Processes"; ~~58 FR 45962, Aug. 31, 1993 as amended at 60 FR 58238, Nov. 27, 1995; 65 FR 61778, Oct. 17, 2000; 65 FR 78279, Dec. 14, 2000~~ as published in the July 1, 2021 Code of Federal Regulations.
- (ll) 40 CFR part 63; "National Emission Standards for Hazardous Air Pollutants for Source Categories"; as published in the July 1, ~~2014~~ 2021 Code of Federal Regulations.

- (mm) 40 CFR part 63, appendix A; "Test Methods Pollutant Measurement Methods from Various Waste Media"; as published in the July 1, ~~2014~~ 2021 Code of Federal Regulations.
- (nn) 40 CFR part 63, subpart G; "National Emissions Standards for Hazardous Air Pollutants from the Synthetic Organic Chemical Manufacturing Industry for Process Vents, Storage Vessels, Transfer Operations, and Wastewater"; as published in the July 1, ~~2014~~ 2021 Code of Federal Regulations.
- (oo) 40 CFR part 63, subpart H; "National Emission Standards for Organic Hazardous Air Pollutants for Equipment Leaks"; as published in the July 1, ~~2014~~ 2021 Code of Federal Regulations.
- (pp) 40 CFR part 63, subpart T; "National Emission Standards for Halogenated Solvent Cleaning"; as published in the July ~~2014~~ 1, 2021 Code of Federal Regulations.
- (qq) 40 CFR part 63, subpart CC; "National Emission Standards for Hazardous Air Pollutants From Petroleum Refineries"; as published in the July 1, ~~2014~~ 2021 Code of Federal Regulations.
- (rr) 40 CFR part 63, subpart SS; "National Emission Standards for Closed Vent Systems, Control Devices, Recovery Devices and Routing to a Fuel Gas System or a Process"; as published in the July 1, ~~2014~~ 2021 Code of Federal Regulations.
- (ss) 40 CFR part 63, subpart JJJ; "National Emissions Standards for Hazardous Air Pollutants: Group IV Polymers and Resins"; as published in the July 1, ~~2014~~ 2021 Code of Federal Regulations.
- (tt) 40 CFR part 63, subpart FFFF; "National "; as published in the July 1, ~~2014~~ 2021 Code of Federal Regulations.
- (uu) 40 CFR part 63, subpart PPPP, appendix A; "Determination of Weight Volatile Matter Content and Weight Solids Content of Reactive Adhesives,"; as published in the July 1, ~~2014~~ 2021 Code of Federal Regulations.
- (vv) 40 CFR part 63, subpart VVVV; "National Emission Standards for Hazardous Air Pollutants for Boat Manufacturing"; as published in the July 1, ~~2014~~ 2021 Code of Federal Regulations.

- (ww) 40 CFR part 63, subpart WWWW; "National Emissions Standards for Hazardous Air Pollutants: Reinforced Plastic Composites Production"; as published in the July 1, ~~2014~~ 2021 Code of Federal Regulations.
- (xx) 40 CFR part 122; "EPA Administered Permit Programs: The National Pollutant Discharge Elimination System"; as published in the July 1, ~~2014~~ 2021 Code of Federal Regulations.
- (yy) 40 CFR part 136; "Guidelines Establishing Test Procedures for the Analysis of Pollutants"; as published in the July 1, ~~2014~~ 2021 Code of Federal Regulations.
- (zz) 40 CFR part 144; "Underground Injection Control Program"; as published in the July 1, ~~2014~~ 2021 Code of Federal Regulations.
- (aaa) 40 CFR part 261; "Identification and Listing of Hazardous Waste"; as published in the July 1, ~~2014~~ 2021 Code of Federal Regulations.
- (bbb) 40 CFR part 264, subpart O; "Standards for Owners and Operators of Hazardous Waste Treatment, Storage and Disposal Facilities; Incinerators"; as published in the July 1, ~~2014~~ 2021 Code of Federal Regulations.
- (ccc) 40 CFR part 265, subpart O; "Interim Status Standards for Owners and Operators of Hazardous Waste Treatment, Storage and Disposal Facilities; Incinerators"; as published in the July 1, ~~2014~~ 2021 Code of Federal Regulations.
- (ddd) 40 CFR part 266, subpart H; "Standards for the Management of Specific Hazardous Wastes and Specific Types of Hazardous Waste Management Facilities; Hazardous Waste Burned in Boilers and Industrial Furnaces"; as published in the July 1, ~~2014~~ 2021 Code of Federal Regulations.
- (eee) 40 CFR part 270; "EPA Administered Permit Programs: The Hazardous Waste Permit Program"; as published in the July 1, ~~2014~~ 2021 Code of Federal Regulations.
- (fff) 46 CFR subchapter Q containing parts 159 to 165; "Equipment, construction, and materials: specifications and approval"; as published in the July 1, ~~2014~~ 2021 Code of Federal Regulations.
- (ggg) 46 CFR subchapter T containing parts 175 to 187; "Small passenger vessels (under 100 gross tons)"; as published in the July 1, ~~2014~~ 2021 Code of Federal Regulations.

- (hhh) AAMA 2604-13; "Voluntary Specification, Performance Requirements and Test Procedures for High Performance Organic Coatings on Aluminum Extrusions and Panels"; published 2013.
- (iii) AAMA 2605-13; "Voluntary Specification, Performance Requirements and Test Procedures for Superior Performing Organic Coatings on Aluminum Extrusions and Panels"; published 2011.
- (jjj) ANSI A135.5-2012; "Prefinished Hardboard Paneling Standard"; 2012.
- (kkk) ANSI B31-3; "Process Piping"; February 14, 2002.
- (lll) ANSI/ASME RTP-1-2011; "Reinforced Thermoset Plastic Corrosion-Resistant Equipment"; 2011.
- (mmm) ANSI/AWWA C950-07; "Fiberglass Pressure Pipe"; approved June 1, 2007.
- (nnn) "API MPMS Chapter 19.2"; "Evaporative Loss from External Floating-roof Tanks"; API, October 2012.
- (ooo) ASME BPVC-X-2013; "ASME Boiler and Pressure Vessel Code (BPVC), Section X: Fiber-reinforced Plastic Pressure Vessels"; approved July 1, 2013.
- (ppp) ASTM C581-03(2008)e1; "Standard Practice for Determining Chemical Resistance of Thermosetting Resins Used in Glass-Fiber-Reinforced Structures Intended for Liquid Service"; approved May 1, 2008.
- (qqq) ASTM D97-11; "Standard Test Method for Pour Point of Petroleum Products"; approved June 1, 2011.
- (rrr) ASTM D244-09; "Standard Test Methods and Practices for Emulsified Asphalt"; approved June 1, 2009.
- (sss) ASTM D322-97(2012); "Standard Test Method for Gasoline Diluent in Used Gasoline Engine Oils by Distillation"; approved November 1, 2012.
- (ttt) ASTM D323-08; "Standard Test Method for Vapor Pressure of Petroleum Products (Reid Method)"; approved December 15, 2008.
- (uuu) ASTM D523-08; "Standard Test Method for Specular Gloss"; approved June 1, 2008.

- (vvv) ASTM D1475-98(2012); "Standard Test Method for Density of Liquid Coatings, Inks, and Related Products"; approved October 10, 1998, reapproved November 1, 2012.
- (www) ASTM D1946-90(2011); "Standard practice for analysis of reformed gas by gas chromatography"; approved 1990, reapproved November 1, 2011.
- (xxx) ASTM D1979-97; "Standard Test Method for Free Formaldehyde Content of Amino Resins"; approved November 10, 1997.
- (yyy) ASTM D2306-00; "Standard Test Method for C8 Aromatic Hydrocarbon Analysis by Gas Chromatography"; approved June 10, 2000.
- (zzz) ASTM D2369-04; "Standard test method for volatile content of coatings"; approved March 1, 2004.
- (aaaa) ASTM D2566-93; "Test Method for Linear Shrinkage of Cured Thermosetting Casting Resins During Cure"; approved 1993.
- (bbbb) ASTM D2879-10; "Standard Test Method for Vapor Pressure-Temperature Relationship and Initial Decomposition Temperature of Liquids by Isoteniscope"; approved October 1, 2010.
- (cccc) ASTM D2996-01(2007)e1; "Standard Specification for Filament-Wound "Fiberglass" (Glass-Fiber-Reinforced Thermosetting-Resin) Pipe"; approved March 1, 2007.
- (dddd) ASTM D2997-01(2007)e1; "Standard Specification for Centrifugally Cast "Fiberglass" (Glass-Fiber-Reinforced Thermosetting-Resin) Pipe"; approved March 15, 2007.
- (eeee) ASTM D3203/D3203M-11; "Standard Test Methods for Percent Air Voids in Compacted Dense and Open Bituminous Paving Mixtures"; approved June 1, 2005.
- (ffff) ASTM D3262-11; "Standard Specification for "Fiberglass" (Glass-Fiber-Reinforced Thermosetting-Resin) Sewer Pipe"; approved September 1, 2011.
- (gggg) ASTM D3299-10; "Standard Specification for Filament-Wound Glass-Fiber-Reinforced Thermoset Resin Corrosion-Resistant Tanks"; April 1, 2010.

- (hhhh) ASTM D3517-11; "Standard Specification for "Fiberglass" (Glass-Fiber-Reinforced Thermosetting-Resin) Pressure Pipe"; September 1, 2011.
- (iiii) ASTM D3754-11; "Standard Specification for "Fiberglass" (Glass-Fiber-Reinforced Thermosetting-Resin) Sewer and Industrial Pressure Pipe"; Approved September 1, 2011.
- (jjjj) ASTM D3792-05(2009); "Standard Test Method for Water Content of Coatings by Direct Injection Into a Gas Chromatograph"; approved June 1, 2009.
- (kkkk) ASTM D3839-08; "Standard Guide for Underground Installation of "Fiberglass" (Glass-Fiber-Reinforced Thermosetting-Resin) Pipe"; approved April 1, 2008.
- (llll) ASTM D3840-10; "Standard Specification for "Fiberglass" (Glass-Fiber-Reinforced Thermosetting-Resin) Pipe Fittings for Nonpressure Applications"; approved September 1, 2011.
- (mmmm) ASTM D3912-10; "Standard Test Method for Chemical Resistance of Coatings and linings for use in Nuclear Power Plants"; approved 1980, reapproved May 15, 2010.
- (nnnn) ASTM D3982-08; "Standard Specification for Contact Molded "Fiberglass" (Glass Fiber Reinforced Thermosetting Resin) Ducts"; approved November 1, 2008.
- (oooo) ASTM D4024-12; "Standard Specification for Machine Made "Fiberglass" (Glass-Fiber-Reinforced Thermosetting Resin) Flanges"; approved May 1, 2012.
- (pppp) ASTM D4082-10; "Standard Test Method for Effects of Gamma Radiation on Coatings for Use in Nuclear Power Plants"; approved 1989, reapproved May 15, 2010.
- (qqqq) ASTM D4097-01(2010); "Standard Specification for Contact-Molded Glass-Fiber-Reinforced Thermoset Resin Corrosion-Resistant Tanks"; approved 2001, reapproved January 1, 2010.
- (rrrr) ASTM D4161-01(2010); "Standard Specification for "Fiberglass" (Glass-Fiber-Reinforced Thermosetting-Resin) Pipe Joints Using Flexible Elastomeric Seals"; approved 2001, reapproved September 1, 2010.

- (ssss) ASTM D4256-89(1994)e1; "Test Method for Determination of the Decontaminability of Coatings Used in Light-Water Nuclear Power Plants"; approved 1994.
- (tttt) ASTM D4457-02(2008); "Standard Test Method for Determination of Dichloromethane and 1,1,1-Trichloroethane in Paints and Coatings by Direct Injection into a Gas Chromatograph"; approved February 1, 2008.
- (uuuu) ASTM ASTM D4953-06(2012); "Standard Test Method for Vapor Pressure of Gasoline and Gasoline-Oxygenate Blends (Dry Method)"; approved November 1, 2012.
- (vvvv) ASTM D5190-07; "Standard Test Method for Vapor Pressure of Petroleum Products (Automatic Method)"; approved November 1, 2007.
- (wwww) ASTM D5191-12; "Standard Test Method for Vapor Pressure of Petroleum Products (Mini Method)"; approved September 1, 2012.
- (xxxx) ASTM D5364-08e1; "Standard Guide for Design, Fabrication, and Erection of Fiberglass Reinforced Plastic Chimney Liners with Coal-Fired Units"; approved November 1, 2008.
- (yyyy) ASTM D5798-12; "Standard Specification for Ethanol Fuel Blends for Flexible-Fuel Automotive Spark-Ignition Engines"; approved December 1, 2012.
- (zzzz) ASTM D5910-12; "Standard Test Method for Determination of Free Formaldehyde in Emulsion Polymers by Liquid Chromatography"; approved November 1, 2012.
- (aaaa) ASTM D6191-97(2008)e1; "Standard Test Method for Measurement of Evolved Formaldehyde from Water Reducible Air-Dry Coatings"; approved November 1, 2008.
- (bbbb) ASTM D6897-09; "Standard Test Method for Vapor Pressure of Liquefied Petroleum Gases (LPG) (Expansion Method)"; approved April 15, 2009.
- (cccc) ASTM D6902-04(2011); "Standard Test Method for Laboratory Measurement of Formaldehyde Evolved During the Curing of Melamine-Formaldehyde-Based Coatings"; approved June 1, 2011.
- (dddd) ASTM E84-12c; "Standard Test Method for Surface Burning Characteristics of Building Materials"; approved November 15, 2012.

- (eeee) ASTM E162-12a; "Standard Test Method for Surface Flammability of Materials Using a Radiant Heat Energy Source"; approved January 15, 2012.
- (ffff) ASTM E168-06; "Standard Practices for General Techniques of Infrared Quantitative Analysis"; approved March 1, 2006.
- (ggggg) ASTM E169-04(2009); "Standard Practices for General Techniques of Ultraviolet-Visible Quantitative Analysis"; approved October 1, 2009.
- (hhhhh) ASTM E260-96(2011); "Standard Practice for Packed Column Gas Chromatography"; approved .November 1, 2011
- (iiii) ASTM E662-13; "Standard Test Method for Specific Optical Density of Smoke Generated by Solid Materials"; approved January 1, 2013.
- (jjjj) ASTM F852-08; "Standard Specification for Portable Gasoline Containers for Consumer Use"; approved July 1, 2008.
- (kkkkk) ASTM F976-08; Standard Specification for Portable Kerosene Containers for Consumer Use"; approved July 1, 2008.
- (llll) ASTM F1216-09; "Standard Practice for Rehabilitation of Existing Pipelines and Conduits by the Inversion and Curing of a Resin- Impregnated Tube"; approved March 1, 2009.
- (mmmmm) ASTM F2234-08; "Standard Specification for Portable Gasoline and Kerosine Spill Resistant Fueling Systems for Consumer Use"; approved March 1, 2008.
- (nnnnn) California Code of Regulations Title 13, Division 3, Chapter 9, Article 6; "Portable Containers and Spouts"; effective January 31, 2014.
- (oooo) Clean Air Act; contained in 42 USC 7401 to 7671q; "The Public Health and Welfare-Air Pollution Prevention and Control"; ~~published January 5, 2009 in Supplement II of the 2006~~ as published in the 2018 edition of the United States Code.
- (ppppp) "Control of Volatile Organic Compound Emissions from Coating Operations at Aerospace Manufacturing and Rework Operations"; EPA-453/R-97-004; December 1997.

- (qqqqq) "Control of Volatile Organic Compound Emissions from Reactor Processes and Distillation Operations Processes in the Synthetic Organic Chemical Manufacturing Industry"; EPA-450/4-91-031; August 1993.
- (rrrrr) "Control Techniques Guidelines for the Oil and Natural Gas Industry"; EPA-453/B-16-001; October 2016.
- ~~(rrrrr)~~(sssss) "CRC Handbook of Chemistry and Physics."; 95th Edition, June 14, 2014.
- ~~(sssss)~~(ttttt) "Early Reduction Program"; 57 Federal Register 61970; December 29, 1992.
- ~~(ttttt)~~(uuuuu) "Federal Insecticide, Fungicide, and Rodenticide Act"; contained in 7 USC 136 to 136y; "Environmental Pesticide Control;" ~~published January 8, 2008 in Supplement I of the 2006~~ as published in the 2018 edition of the United States Code.
- ~~(uuuuu)~~(vvvvv) "Federal Motor Vehicle Safety Standards"; contained in 49 CFR part 571; as published in the July 1, ~~2014~~ 2021 Code of Federal Regulations.
- ~~(vvvvv) "Guidance for Estimating Capital and Annual Costs of Air Pollution Systems"; Ohio EPA engineering guide 46; March 1983.~~
- (wwwww) "Guidelines for Determining Capture Efficiency"; USEPA office of air and radiation, policy and guidance; February 7, 1995.
- (xxxxx) IAPMO/ANSI Z1000-2007; "American National Standard for Prefabricated Septic Tanks"; approved January 1, 2007.
- (yyyyy) "Lange's Handbook of Chemistry"; 70th Edition, Januray 10, 2005.
- (zzzzz) "Methods for the "; EPA 821/C-99-004; published May 1, 1999.
- (aaaaa) MIL-A-87721; reference contained in "Control of Volatile Organic Compound Emissions from Coating Operations at Aerospace Manufacturing and Rework Operations."
- (bbbbbb) MIL-STD-1330C(SH); "Military Standard: Cleaning and Testing of Shipboard Oxygen, Nitrogen and Hydrogen Gas Piping Systems"; approved February 1, 1985.

- (ccccc) NFPA 30B; "Code for the Manufacture and Storage of Aerosol Products"; 2011 edition, approved June 21, 2010.
- (dddddd) "Perry's Chemical Engineer's Handbook"; eighth edition, November 13, 2007.
- (eeeeee) "Protocol for Determining the Daily Volatile Organic Compound Emission Rate of Automobile and Light-Duty Truck Topcoat Operations"; EPA-453/R-08-002 September 2008.
- (ffffff) "Recommended Practices for Installation and Testing of Vapor Recovery Systems at Vehicle Refueling Sites"; PEI/RP300-09; fourth edition.
- (gggggg) "Regulatory Guide 1.54 - Service Level I, II and III Protective Coatings Applied to Nuclear Plants"; issued July, 2000.
- (hhhhh) SE-R-0006; "General Specification Space Shuttle System Requirements for Materials and Processes"; revision C; April 26, 1990.
- (iiiiii) Section 182 of the Clean Air Act; contained in 42 USC 7511a; "Plan submissions and requirements"; ~~published January 5, 2009 in supplement H of the 2006~~ as published in the 2018 edition of the United States Code.
- (jjjjj) Section 193 of the Clean Air Act; contained in 42 USC 7515; "General savings clause"; ~~published January 5, 2009 in supplement H of the 2006~~ as published in the 2018 edition of the United States Code.
- (kkkkk) South Coast Air Quality Management District (SCAQMD) Method 312-91; "Determination of Percent Monomer in Polyester Resins"; approved June 1, 1991, revised April, 1996.
- (lllll) South Coast Air Quality Management District (SCAQMD) Method 316A; "Determination of Volatile Organic Compounds (VOC) in Materials Used for Pipes and Fittings"; approved September 9, 1992, revised October 1996.
- (mmmmm) SSP 30233F; "Space Station Requirements for Materials and Processes - International Space Stations"; March 6, 1998.
- (nnnnn) "Standard Industrial Classification Manual." United States Office of Management and Budget, last amended 1988.

- (oooooo) Standard method 5310D; contained in "Standard Methods for the Examination of Water and Wastewater"; twenty-second edition, 2012.
- (pppppp) "Standard Methods for the Examination of Water and Wastewater; twenty-second edition, 2012.
- (qqqqqq) SW-846; "Test Methods for Evaluating Solid Waste, Physical/Chemical Methods"; last updated February 2007.
- (rrrrrr) SW-846 method 5021; "Volatile Organic Compounds in Soils and Other Solid Matrices Using Equilibrium Headspace Analysis"; revision 0, December 1996.
- (ssssss) SW-846 method 5030B; "Purge-and-trap for Aqueous Samples"; revision 2, December 1996.
- (tttttt) SW-846 method 8015C; "Nonhalogenated Organics Using GC/FID"; revision 3, February 2007.
- (uuuuuu) SW-846 method 8021B; "Aromatic and Halogenated Volatiles by Gas Chromatography Using Photoionization and/or Electrolytic Conductivity Detectors"; revision 2, December 1996.
- (vvvvvv) SW-846 method 8260B; "Volatile Organic Compounds by Gas Chromatography/Mass Spectrometry (GC/MS)"; revision 2, December 1996.
- (wwwwww) SW-846 method 9060A; "Total Organic Carbon"; revision 1, November 2004.
- (xxxxxx) UL 1316; "Glass-Fiber-Reinforced Plastic Underground Storage Tanks for Petroleum Products, Alcohols, and Alcohol-Gasoline Mixtures"; second edition, January 7, 1994.
- (yyyyyy) UL 1746; "Standard for External Corrosion Protection Systems for Steel Underground Storage Tanks"; third edition, January 17, 2007.
- (zzzzzz) UL 2215; "Outline of Investigation for Oil/Water Separators"; second edition, June 23, 2000.
- (aaaaaaa) UL 330; "Underwriters Laboratories' Standard for Hose and Hose Assemblies for Dispensing Flammable Liquids"; seventh edition, December 16, 2009.

- (bbbbbbb) USEPA-approved alternative test method ALT-020; "Negative Pressure Enclosure Qualitative Test Method for Bakery Ovens"; posted November 15, 2000.
- (ccccccc) USEPA conditional test method CTM-042; "Use of Flame Ionization Detector-Methane Cutter Analysis Systems for VOC Compliance Testing of Bakeries"; revised August 18, 2004; posted September 3, 2004.
- (ddddddd) USEPA method 1; contained in 40 CFR part 60, appendix A; "Sample and velocity traverses for stationary sources"; as published in the July 1, ~~2014~~ 2021 Code of Federal Regulations.
- (eeeeeee) USEPA method 1A; contained in 40 CFR part 60, appendix A; "Sample and velocity traverses for stationary sources with small stacks or ducts"; as published in the July 1, ~~2014~~ 2021 Code of Federal Regulations.
- (ffffff) USEPA method 2; contained in 40 CFR part 60, appendix A; "Determination of stack gas velocity and volumetric flow rate (Type S pitot tube)"; as published in the July 1, ~~2014~~ 2021 Code of Federal Regulations.
- (ggggggg) USEPA method 2A; contained in 40 CFR part 60, appendix A; "Direct measurement of gas volume through pipes and small ducts"; as published in the July 1, ~~2014~~ 2021 Code of Federal Regulations.
- (hhhhhhh) USEPA method 2B; contained in 40 CFR part 60, appendix A; "Determination of exhaust gas volume flow rate from gasoline vapor incinerators"; as published in the July 1, ~~2014~~ 2021 Code of Federal Regulations.
- (iiiiiii) USEPA method 2C; contained in 40 CFR part 60, appendix A; "Determination of gas velocity and volumetric flow rate in small stacks or ducts (standard pilot tube)"; as published in the July 1, ~~2014~~ 2021 Code of Federal Regulations.
- (jjjjjjj) USEPA method 2D; contained in 40 CFR part 60, appendix A; "Measurement of gas volume flow rates in small pipes and ducts"; as published in the July 1, ~~2014~~ 2021 Code of Federal Regulations.
- (kkkkkkk) USEPA method 3; contained in 40 CFR part 60, appendix A; "Gas analysis for the determination of dry molecular weight"; as published in the July 1, ~~2014~~ 2021 Code of Federal Regulations.

- (lllllll) USEPA method 3A; contained in 40 CFR part 60, appendix A; "Determination of oxygen and carbon dioxide concentrations in emissions from stationary sources (instrumental analyzer procedure)"; as published in the July 1, ~~2014~~ 2021 Code of Federal Regulations.
- (mmmmmmm) USEPA method 3B; contained in 40 CFR part 60, appendix A; "Gas analysis for the determination of emission rate correction factor or excess air"; as published in the July 1, ~~2014~~ 2021 Code of Federal Regulations.
- (nnnnnnn) USEPA method 4; contained in 40 CFR part 60, appendix A; "Determination of moisture content in stack gases"; as published in the July 1, ~~2014~~ 2021 Code of Federal Regulations.
- (ooooooo) USEPA method 18; contained in 40 CFR part 60, appendix A; "Measurement of gaseous organic compound emissions by gas chromatograph"; as published in the July 1, ~~2014~~ 2021 Code of Federal Regulations.
- (ppppppp) USEPA method 21; contained in 40 CFR part 60, appendix A; "Determination of volatile organic compound leaks"; as published in the July 1, ~~2014~~ 2021 Code of Federal Regulations.
- (qqqqqqq) USEPA method 22; contained in 40 CFR part 60, appendix A; "Visual determination of fugitive emissions from material sources and smoke emissions from flares"; as published in the July 1, ~~2014~~ 2021 Code of Federal Regulations.
- (rrrrrrr) USEPA method 24; contained in 40 CFR part 60, appendix A; "Determination of volatile matter content, water content, density, volume solids, and weight solids of surface coatings"; as published in the July 1, ~~2010~~~~2014~~ 2021 Code of Federal Regulations.
- (sssssss) USEPA method 24A; contained in 40 CFR part 60, appendix A; "Determination of volatile matter content and density of publication rotogravure inks and related publication rotogravure coatings"; as published in the July 1, ~~2014~~ 2021 Code of Federal Regulations.
- (ttttttt) USEPA method 25; contained in 40 CFR part 60, appendix A; "Determination of total gaseous nonmethane organic emissions as carbon"; as published in the July 1, ~~2010~~~~2014~~ 2021 Code of Federal Regulations.

- (uuuuuuu) USEPA method 25A; contained in 40 CFR part 60, appendix A; "Determination of total gaseous organic concentration using a flame ionization analyzer"; as published in the July 1, ~~2014~~ 2021 Code of Federal Regulations.
- (vvvvvvv) USEPA method 25B; contained in 40 CFR part 60, appendix A; "Determination of total gaseous organic concentration using a nondispersive infrared analyzer"; as published in the July 1, ~~2014~~ 2021 Code of Federal Regulations.
- (wwwwwww) USEPA method 25D; contained in 40 CFR part 60, appendix A; "Determination of the volatile organic concentration of waste samples"; as published in the July 1, ~~2014~~ 2021 Code of Federal Regulations.
- (xxxxxxx) USEPA method 26; contained in 40 CFR part 60, appendix A; "Determination of hydrogen halide and halogen emissions from stationary sources - non-isokinetic method"; as published in the July 1, ~~2014~~ 2021 Code of Federal Regulations.
- (yyyyyyy) USEPA method 26A; contained in 40 CFR part 60, appendix A; "Determination of hydrogen halide and halogen emissions from stationary sources-isokinetic method"; as published in the July 1, ~~2014~~ 2021 Code of Federal Regulations.
- (zzzzzzz) USEPA method 27; contained in 40 CFR part 60, appendix A; "Determination of vapor tightness of gasoline delivery tank using pressure-vacuum test"; as published in the July 1, ~~2014~~ 2021 Code of Federal Regulations.
- (aaaaaaaa) USEPA method 160.2 contained in "Methods for chemical analysis of water and wastes"; EPA 821/C-99-004; published May 1, 1999.
- (bbbbbbbb) USEPA method 204; contained in 40 CFR part 51, appendix M; "Criteria for and verification of a permanent or temporary total enclosure"; as published in the July 1, ~~2014~~ 2021 Code of Federal Regulations.
- (ccccccc) USEPA method 204A; contained in 40 CFR part 51, appendix M; "Volatile organic compounds content in liquid input stream"; as published in the July 1, ~~2014~~ 2021 Code of Federal Regulations.
- (ddddddd) USEPA method 204B; contained in 40 CFR part 51, appendix M; "Volatile organic compounds emissions in captured stream"; as published in the July 1, ~~2014~~ 2021 Code of Federal Regulations.

- (eeeeeeee) USEPA method 204C; contained in 40 CFR part 51, appendix M; " Volatile organic compounds emissions in captured stream (dilution technique)"; as published in the July 1, ~~2014~~ 2021 Code of Federal Regulations.
- (ffffff) USEPA method 204D; contained in 40 CFR part 51, appendix M; " Volatile organic compounds emissions in uncaptured stream from temporary total enclosure"; as published in the July 1, ~~2014~~ 2021 Code of Federal Regulations.
- (gggggggg) USEPA method 204E; contained in 40 CFR part 51, appendix M; " Volatile organic compounds emissions in uncaptured stream from building enclosure"; as published in the July 1, ~~2014~~ 2021 Code of Federal Regulations.
- (hhhhhhh) USEPA method 204F; contained in 40 CFR part 51, appendix M; " Volatile organic compounds content in liquid input stream (distillation approach)"; as published in the July 1, ~~2014~~ 2021 Code of Federal Regulations.
- (iiiiiii) USEPA method 301; contained in 40 CFR part 63, appendix A; "Field validation of pollutant measurement methods from various waste media"; as published in the July 1, ~~2014~~ 2021 Code of Federal Regulations.
- (jjjjjjj) USEPA method 305; contained in 40 CFR part 63, appendix A; "Measurement of emission potential of individual volatile organic compounds in waste"; as published in the July 1, ~~2014~~ 2021 Code of Federal Regulations.
- (kkkkkkk) USEPA method 602; contained in 40 CFR part 136, appendix A; "Purgeable aromatics"; as published in the July 1, ~~2014~~ 2021 Code of Federal Regulations.
- (lllllll) USEPA method 624; contained in 40 CFR part 136, appendix A; "Purgeables"; as published in the July 1, ~~2014~~ 2021 Code of Federal Regulations.
- (mmmmmmm) USEPA method 625; contained in 40 CFR part 136, appendix A; "Base/neutrals and acids"; as published in the July 1, ~~2014~~ 2021 Code of Federal Regulations.
- (nnnnnnn) USEPA method 1624; contained in 40 CFR part 136, appendix A; "Volatile organic compounds by isotope dilution GC/MS"; as published in the July 1, ~~2014~~ 2021 Code of Federal Regulations.

(oooooooo) USEPA method 1625; contained in 40 CFR part 136, appendix A; "Semivolatile organic compounds by isotope dilution GC/MS"; as published in the July 1, ~~2014~~ 2021 Code of Federal Regulations.

(pppppppp) WATER9; version 3.0, released June 29, 2006.

Effective: 3/27/2022
Five Year Review (FYR) Dates: 11/29/2021 and 11/29/2026

CERTIFIED ELECTRONICALLY

Certification

03/17/2022

Date

Promulgated Under: 119.03
Statutory Authority: 3704.03(E)
Rule Amplifies: 3704.03(A), 3704.03(E)
Prior Effective Dates: 02/15/1972, 10/19/1979, 03/27/1981, 06/21/1982,
01/24/1983, 05/09/1986, 05/25/1988, 08/22/1990,
06/14/1991, 03/31/1993, 11/05/2002, 05/27/2005,
02/10/2006, 08/25/2008, 04/02/2009, 05/12/2011,
10/15/2015

3745-21-04

Compliance time schedules.

[Comment: For dates and availability of non-regulatory government publications, publications of recognized organizations and associations, federal rules, and federal statutory provisions referenced in this rule, see paragraph (JJ) of rule 3745-21-01 of the Administrative Code titled "referenced materials."]

(A) [Reserved.]

(B) Certification and permit application requirements.

(1) Except as otherwise provided in paragraphs (B)(2) to (B)(4), and (B)(7) of this rule, by no later than December 1, 1979 for any air contaminant source subject to paragraphs (C) to (S) of rule 3745-21-09 of the Administrative Code, by no later than April 1, 1981 for any air contaminant source subject to paragraphs (T) to (AA) of rule 3745-21-09 of the Administrative Code, by no later than June 1, 1986 for any air contaminant source subject to paragraphs (BB) to (EE) of rule 3745-21-09 of the Administrative Code, by no later than June 1, 1988 for any air contaminant source subject to paragraphs (FF) to (PP) of rule 3745-21-09 of the Administrative Code, and by no later than May 1, 1993 for any air contaminant source subject to paragraphs (QQ) to (DDD) of rule 3745-21-09 of the Administrative Code, any owner or operator of said air contaminant source shall comply with one of the following:

(a) Certify in writing to the director that such source is in compliance with all requirements of rule 3745-21-09 of the Administrative Code: ~~Such certification shall include including the following: equipment description, Ohio EPA permit application number (if assigned), and all necessary data (consistent with the appropriate permit application appendices or emission activity category forms) and calculations which confirm the compliance status. The certification shall also include an application for a permit authorizing operation of such source in accordance with rule 3745-21-09 of the Administrative Code if such source does not possess an effective permit, or, if applicable.~~

(i) Equipment description.

(ii) Ohio EPA permit application number (if assigned).

(iii) All necessary data (consistent with the appropriate permit application appendices or emission activity category forms) and calculations which confirm the compliance status.

(iv) An application for a permit authorizing operation of such source in accordance with rule 3745-21-09 of the Administrative Code if such source does not possess an effective permit.

- (b) Submit an application for an operating permit or an application for a modification to an operating permit in accordance with Chapter 3745-77 of the Administrative Code, for sources subject to the Title V program, or in accordance with Chapter 3745-31 of the Administrative Code, for sources not subject to the Title V program. ~~Such application shall include~~ including a compliance program which will bring the source into compliance with rule 3745-21-09 of the Administrative Code as expeditiously as practicable but in no event later than the dates specified in paragraph (C) of this rule; and ~~shall identify~~ identifies all reasonable interim control measures.

[Comment: Applications requiring submittal prior to June 30, 2008, for sources not subject to the Title V program, were to be submitted in accordance with Chapter 3745-35 of the Administrative Code.]

- (2) The certification or operating permit application required by paragraph (B)(1) of this rule shall not apply to any air contaminant sources subject exclusively to paragraph (N) or (V) of rule 3745-21-09 of the Administrative Code (pertaining to cutback asphalts and gasoline tank trucks).
- (3) For any air contaminant source subject to the following:
- (a) Paragraphs (C)(3)(c), (C)(4)(b), (C)(5)(b), (C)(6)(b), (C)(8)(b), (C)(8)(c), (C)(9)(b), (C)(10)(b), (C)(19)(b) to (C)(19)(d), (C)(28)(b), (C)(28)(c), (C)(65), and (C)(66) of this rule, a certification or operating permit application shall be submitted in accordance with paragraphs (B)(1)(a) and (B)(1)(b) of this rule by no later than May 1, 1993.
- (b) Paragraphs (C)(5)(d), (C)(8)(e), ~~and (C)(10)(d), (C)(16)(d), and (C)(32)(b)~~ of this rule, a certification or operating permit application shall be submitted in accordance with paragraphs (B)(1)(a) and (B)(1)(b) of this rule by no later than July 31, 2009.
- (c) Paragraphs (C)(5)(f), (C)(8)(g), (C)(10)(f), and (C)(32)(c) of this rule, a certification or operating permit application shall be submitted in accordance with paragraphs (B)(1)(a) and (B)(1)(b) of this rule by no later than sixty days after the effective date of this rule.

- (4) For any air contaminant source subject to paragraphs (C)(3)(d) and (C)(28)(d) of this rule, a certification or operating permit application shall be submitted in accordance with paragraphs (B)(1)(a) and (B)(1)(b) of this rule by no later than March 1, 1995.
- (5) In demonstrating compliance pursuant to paragraph (B)(1)(a) of this rule, the owner or operator of a source shall utilize the test methods and procedures specified in rule 3745-21-10 of the Administrative Code. In addition, for any source that is located within one of the counties specified in paragraph (A) of rule 3745-21-09 of the Administrative Code, employs add-on controls to comply with rule 3745-21-09 of the Administrative Code, and has not been tested since January 1, 1991, the owner or operator of such source shall conduct emission tests in accordance with the methods specified in rule 3745-21-10 of the Administrative Code to demonstrate compliance with rule 3745-21-09 of the Administrative Code. The emission tests shall be conducted by January 17, 1996. For the purpose of complying with the emission test requirement specified in this paragraph, the Ohio EPA may accept an emission test conducted prior to January 1, 1991, if the owner or operator provides information and data to the Ohio EPA which demonstrate that the test was witnessed by the Ohio EPA or its delegated agent, that an approved USEPA emission test method was employed, and that the operation of the source was consistent with the current source operating conditions and operating capacity. For each coating employed in any coating line that is located within one of the counties specified in paragraph (A) of rule 3745-21-09 of the Administrative Code and is subject to rule 3745-21-09 of the Administrative Code, the owner or operator shall demonstrate compliance with any applicable VOC content limitation specified in rule 3745-21-09 of the Administrative Code using USEPA method 24 (for coatings) or USEPA method 24A (for flexographic and rotogravure printing inks and related coatings). If any such coating has not been analyzed using USEPA method 24 or USEPA method 24A since January 1, 1991, the owner or operator shall either conduct a USEPA method 24 or USEPA method 24A analysis of the coating or obtain a USEPA method 24 or USEPA method 24A analysis of the coating from the coating supplier by January 17, 1996. If, pursuant to section 11.4 of USEPA method 24, as contained in 40 CFR part 60 appendix A, an owner or operator determines that USEPA method 24 or USEPA method 24A cannot be used for a particular coating or ink, the owner or operator shall so notify the administrator of the USEPA and shall use formulation data for that coating or ink to demonstrate compliance until the USEPA provides alternative analytical procedures or alternative precision statements for USEPA method 24 or USEPA method 24A.

- (6) The owner or operator of a source that is subject to rule 3745-21-09 of the Administrative Code shall notify the director in writing at least thirty days before any impending change in the method of complying with said requirements.
- (7) For any air contaminant source subject to paragraph (C)(28)(e) of this rule a compliance certification or compliance program, along with an operating permit application, if appropriate, shall be submitted in accordance with paragraphs (B)(1)(a) and (B)(1)(b) of this rule by no later than August 15, 1999. For any air contaminant source subject to paragraph (C)(28)(e) of this rule and located at a facility subject to Chapter 3745-77 of the Administrative Code, ~~the owner or operator shall only submit a compliance certification or a compliance program, but no an operating permit application is not required, in accordance with paragraphs (B)(1)(a) and (B)(1)(b) of this rule by no later than August 15, 1999.~~

(C) Compliance time schedules.

- (1) No owner or operator may cause, permit, or allow the operation or other use of any air contaminant source in violation of the limitations specified in rule 3745-21-07 or 3745-21-08 of the Administrative Code beyond April 15, 1977.
- (2) Except as otherwise provided in paragraphs (C)(21) to (C)(26) and (C)(35) of this rule, any owner or operator of an automobile or light-duty truck assembly plant which is subject to paragraph (C) of rule 3745-21-09 of the Administrative Code shall achieve compliance with said requirements by December 1, 1982.
- (3) Can coating lines.
 - (a) Except as provided in paragraphs (C)(3)(b), (C)(3)(c), and (C)(3)(d) of this rule, any owner or operator of a can coating line which is subject to paragraph (D) of rule 3745-21-09 of the Administrative Code shall achieve compliance with said requirements by April 1, 1982.
 - (b) [Reserved.]
 - (c) Any owner or operator of a can coating line which employs a control system shall achieve compliance with either the control requirements specified in paragraph (B)(6) of rule 3745-21-09 of the Administrative Code or the VOC limitation which is contained in paragraph (D) of rule 3745-21-09 of the Administrative Code and expressed in terms of pounds of VOC per gallon of solids by April 1, 1995.

- (d) Any owner or operator of an end sealing compound coating line used for food can ends shall achieve compliance with paragraphs (D)(1)(e) and (D)(2)(e) of rule 3745-21-09 of the Administrative Code no later than January 17, 1996. Any owner or operator of a two-piece or three-piece can coating operation which has an end sealing compound coating line and which is subject to the alternative daily emission limitation of paragraph (D)(3) of rule 3745-21-09 of the Administrative Code shall achieve compliance with paragraph (D) of rule 3745-21-09 of the Administrative Code no later than January 17, 1996.

(4) Coil coating lines.

- (a) Except as otherwise provided in paragraphs (C)(4)(b) and (C)(20) of this rule, any owner or operator of a coil coating line which is subject to paragraph (E) of rule 3745-21-09 of the Administrative Code shall achieve compliance with said requirements by April 1, 1982.
- (b) Any owner or operator of a coil coating line which employs a control system shall achieve compliance with either the control requirements specified in paragraph (B)(6) of rule 3745-21-09 of the Administrative Code or the VOC limitation which is contained in paragraph (E) of rule 3745-21-09 of the Administrative Code and expressed in terms of pounds of VOC per gallon of solids by April 1, 1995.

(5) Paper coating lines.

- (a) Except as otherwise provided in paragraph (C)(5)(b) of this rule, any owner or operator of a paper coating line which is subject to paragraph (F)(1) of rule 3745-21-09 of the Administrative Code shall achieve compliance with said requirements by April 1, 1982.
- (b) Any owner or operator of a paper coating line which employs a control system shall achieve compliance with either the control requirements specified in paragraph (B)(6) of rule 3745-21-09 of the Administrative Code or the VOC limitation which is contained in paragraph (F)(1) of rule 3745-21-09 of the Administrative Code and expressed in terms of pounds of VOC per gallon of solids by April 1, 1995.
- (c) Any owner or operator of a paper coating line located in Ashtabula, Cuyahoga, Geauga, Lake, Lorain, Medina, Portage, or Summit county which is subject to paragraph (F)(2) of rule 3745-21-09 of the Administrative Code shall achieve compliance with said requirements by no later than April 2, 2010.

- (d) Any owner or operator of a paper coating line located in Ashtabula, Cuyahoga, Geauga, Lake, Lorain, Medina, Portage, or Summit county which employs an add-on control system shall achieve compliance with the control requirements specified in paragraph (B)(7) of rule 3745-21-09 of the Administrative Code by no later than April 2, 2010.
 - (e) Any owner or operator of a paper coating line located in Butler, Clermont, Hamilton or Warren county which is subject to paragraph (F)(2) of rule 3745-21-09 of the Administrative Code shall achieve compliance with said requirements by no later than March 1, 2023.
 - (f) Any owner or operator of a paper coating line located in Butler, Clermont, Hamilton or Warren county which employs an add-on control system shall achieve compliance with the control requirements specified in paragraph (B)(7) of rule 3745-21-09 of the Administrative Code by no later than March 1, 2023.
- (6) Fabric coating lines.
- (a) Except as otherwise provided in paragraph (C)(6)(b) of this rule, any owner or operator of a fabric coating line which is subject to paragraph (G) of rule 3745-21-09 of the Administrative Code shall achieve compliance with said requirements by April 1, 1982.
 - (b) Any owner or operator of a fabric coating line which employs control system shall achieve compliance with either the control requirements specified in paragraph (B)(6) of rule 3745-21-09 of the Administrative Code or the VOC limitation which is contained in paragraph (G) of rule 3745-21-09 of the Administrative Code and expressed in terms of pounds of VOC per gallon of solids by April 1, 1995.
- (7) Any owner or operator of a vinyl coating line which is subject to paragraph (H) of rule 3745-21-09 of the Administrative Code shall achieve compliance with said requirements by April 1, 1982.
- (8) Metal furniture coating lines.
- (a) Except as otherwise provided in paragraphs (C)(8)(b) and (C)(8)(c) of this rule, any owner or operator of a metal furniture coating line which is subject to ~~paragraph (F)~~ paragraphs (I)(1) to (I)(2) of rule 3745-21-09 of the Administrative Code shall achieve compliance with said requirements by April 1, 1982.

- (b) Any owner or operator of a metal furniture coating line which employs a control system shall achieve compliance with either the control requirements specified in paragraph (B)(6) of rule 3745-21-09 of the Administrative Code or the VOC limitation which is contained in ~~paragraph (I)~~ paragraphs (I)(1) to (I)(2) of rule 3745-21-09 of the Administrative Code and expressed in terms of pounds of VOC per gallon of solids by April 1, 1995.
- (c) Any owner or operator of a metal furniture coating line which, prior to March 31, 1993, was exempt from ~~paragraph (I)~~ paragraphs (I)(1) to (I)(2) of rule 3745-21-09 of the Administrative Code, but is no longer exempt due to the change in the exemption criterion specified in paragraph (I)(3)(a) of rule 3745-21-09 of the Administrative Code, shall achieve compliance with ~~paragraph (I)~~ paragraphs (I)(1) to (I)(2) of rule 3745-21-09 of the Administrative Code by April 1, 1995.
- (d) Any owner or operator of a metal furniture coating line located in Ashtabula, Cuyahoga, Geauga, Lake, Lorain, Medina, Portage, or Summit county which is subject to paragraph (I)(4) of rule 3745-21-09 of the Administrative Code shall achieve compliance with said requirements by no later than April 2, 2010.
- (e) Any owner or operator of a metal furniture coating line located in Ashtabula, Cuyahoga, Geauga, Lake, Lorain, Medina, Portage, or Summit county which employs an add-on control system shall achieve compliance with either the control requirements specified in paragraph (B)(7) of rule 3745-21-09 of the Administrative Code or the VOC limitation specified in the table of paragraph (I)(4) of rule 3745-21-09 of the Administrative Code and expressed in terms of pounds of VOC per gallon of deposited solids by no later than April 2, 2010.
- (f) Any owner or operator of a metal furniture coating line located in Butler, Clermont, Hamilton or Warren county which is subject to paragraph (I)(4) of rule 3745-21-09 of the Administrative Code shall achieve compliance with said requirements by no later than March 1, 2023.
- (g) Any owner or operator of a metal furniture coating line located in Butler, Clermont, Hamilton or Warren county which employs an add-on control system shall achieve compliance with either the control requirements specified in paragraph (B)(7) of rule 3745-21-09 of the Administrative Code or the VOC limitation specified in the table of paragraph (I)(4) of rule 3745-21-09 of the Administrative Code and expressed in terms of

pounds of VOC per gallon of deposited solids by no later than March 1, 2023.

(9) Magnet wire coating lines.

- (a) Except as otherwise provided in paragraph (C)(9)(b) of this rule, any owner or operator of a magnet wire coating line which is subject to paragraph (J) of rule 3745-21-09 of the Administrative Code shall achieve compliance with said requirements by November 1, 1981.
- (b) Any owner or operator of a magnet wire coating line which employs a control system shall achieve compliance with either the control requirements specified in paragraph (B)(6) of rule 3745-21-09 of the Administrative Code or the VOC limitation which is contained in paragraph (J) of rule 3745-21-09 of the Administrative Code and expressed in terms of pounds of VOC per gallon of solids by April 1, 1995.

(10) Large appliance coating lines.

- (a) Except as otherwise provided in paragraph (C)(10)(b) of this rule, any owner or operator of a large appliance coating line which is subject to ~~paragraph (K)~~ ~~paragraphs (K)(1) to (K)(5)~~ of rule 3745-21-09 of the Administrative Code shall achieve compliance with said requirements by April 1, 1982.
- (b) Any owner or operator of a large appliance coating line which employs a control system shall achieve compliance with either the control requirements specified in paragraph (B)(6) of rule 3745-21-09 of the Administrative Code or the VOC limitation which is contained in ~~paragraph (K)~~ ~~paragraphs (K)(1) to (K)(5)~~ of rule 3745-21-09 of the Administrative Code and expressed in terms of pounds of VOC per gallon of solids by April 1, 1995.
- (c) Any owner or operator of a large appliance coating line located in Ashtabula, Cuyahoga, Geauga, Lake, Lorain, Medina, Portage, or Summit county which is subject to paragraph (K)(6) of rule 3745-21-09 of the Administrative Code shall achieve compliance with said requirements by no later than April 2, 2010.
- (d) Any owner or operator of a large appliance coating line located in Ashtabula, Cuyahoga, Geauga, Lake, Lorain, Medina, Portage, or Summit county which employs a control system shall achieve compliance with either the control requirements specified in paragraph (B)(7) of rule 3745-21-09

of the Administrative Code or the VOC limitation which is contained in paragraph (K)(6) of rule 3745-21-09 of the Administrative Code and expressed in terms of pounds of VOC per gallon of deposited solids by no later than April 2, 2010.

(e) Any owner or operator of a large appliance coating line located in Butler, Clermont, Hamilton or Warren county which is subject to paragraph (K)(6) of rule 3745-21-09 of the Administrative Code shall achieve compliance with said requirements by no later than March 1, 2023.

(f) Any owner or operator of a large appliance coating line located in Butler, Clermont, Hamilton or Warren county which employs a control system shall achieve compliance with either the control requirements specified in paragraph (B)(7) of rule 3745-21-09 of the Administrative Code or the VOC limitation which is contained in paragraph (K)(6) of rule 3745-21-09 of the Administrative Code and expressed in terms of pounds of VOC per gallon of deposited solids by no later than March 1, 2023.

- (11) Any owner or operator of a fixed roof tank which is subject to paragraph (L) of rule 3745-21-09 of the Administrative Code shall achieve compliance with said requirements by January 1, 1982.
- (12) Any owner or operator of a refinery vacuum producing system which is subject to paragraph (M)(1) of rule 3745-21-09 of the Administrative Code shall achieve compliance with said requirements by December 31, 1982.
- (13) Any owner or operator of a refinery wastewater separator which is subject to paragraph (M)(2) of rule 3745-21-09 of the Administrative Code shall achieve compliance with said requirements by January 1, 1981.
- (14) Any owner or operator of a refinery process unit turnaround which is subject to paragraph (M)(3) of rule 3745-21-09 of the Administrative Code shall achieve compliance with said requirements by December 31, 1982.
- (15) Paragraph (N) of rule 3745-21-09 of the Administrative Code shall be complied with by the following deadlines:
 - (a) April 15, 1981 for the use or application of cutback asphalts in road construction and maintenance; and
 - (b) April 15, 1982 for the use or application of emulsified asphalts in road construction and maintenance.
- (16) Solvent metal cleaning operations.

- (a) Except as provided in paragraphs (C)(16)(b) to (C)(16)(d) of this rule, any owner or operator of a solvent metal cleaning operation which is subject to paragraph (O) of rule 3745-21-09 of Administrative Code shall achieve compliance with said requirements by April 1, 1981.
 - (b) Any owner or operator of a solvent metal cleaning operation shall achieve compliance with paragraphs (O)(2)(d), (O)(3)(d), and (O)(4)(e) of rule 3745-21-09 of the Administrative Code by July 17, 1995.
 - (c) Any owner or operator of a cold cleaning operation which is located in Butler, Clark, Clermont, Greene, Hamilton, Miami, Montgomery, or Warren county shall achieve compliance with paragraph (O)(2)(e) of rule 3745-21-09 of the Administrative Code by May 1, 2006.
 - (d) Any owner or operator of a cold cleaning operation which is located in Ashtabula, Cuyahoga, Geauga, Lake, Lorain, Medina, Portage, or Summit county shall achieve compliance with paragraph (O)(2)(e) of the Administrative Code by no later than April 2, 2010.
- (17) Any owner or operator of a bulk gasoline plant which is subject to paragraph (P) of rule 3745-21-09 of the Administrative Code shall achieve compliance with said requirements by July 1, 1981.
- (18) Any owner or operator of a bulk gasoline terminal which is subject to paragraph (Q) of rule 3745-21-09 of the Administrative Code shall achieve compliance with said requirements by July 1, 1981.
- (19) Any owner or operator of a gasoline dispensing facility which is subject to paragraph (R) of rule 3745-21-09 of the Administrative Code shall achieve compliance with said requirements no later than the deadlines in the following schedules:
- (a) Except as otherwise provided in paragraphs (C)(19)(b) to (C)(19)(d) of this rule, for any gasoline dispensing facility which has an annual throughput equal to or greater than two hundred forty thousand gallons of gasoline by July 1, 1981.
 - (b) For any gasoline dispensing facility which is located in Ashtabula, Clark, Geauga, or Miami county: and for which construction commenced after November 15, 1990 and prior to March 31, 1993 by September 30, 1993.
 - (c) For any gasoline dispensing facility which is located in Ashtabula, Clark, Geauga, or Miami county and which dispenses at least one hundred thousand gallons of gasoline per month (based upon the average monthly

sales of gasoline during the period from November 16, 1990 through November 15, 1992): by March 31, 1994.

- (d) For any other gasoline dispensing facility which is located in Ashtabula, Clark, Geauga, or Miami county and which is not covered by paragraph (C)(19)(b) or (C)(19)(c) of this rule, or for any gasoline dispensing facility which is located in Delaware or Licking county and which has an annual throughput equal to or greater than one hundred twenty thousand gallons of gasoline, or for any gasoline dispensing facility which is located in Butler, Clermont, Cuyahoga, Franklin, Greene, Hamilton, Lake, Lorain, Lucas, Mahoning, Medina, Montgomery, Portage, Stark, Summit, Trumbull, Warren, or Wood county and which has an annual throughput equal to or greater than one hundred twenty thousand gallons of gasoline and less than two hundred forty thousand gallons of gasoline by March 31, 1995.
- (20) "~~Alside, Inc. Associated Materials~~", facility ID 1677000053, or any subsequent owner or operator of the "~~Alside, Inc. Associated Materials~~" facility located at 3773 State road, Cuyahoga Falls, Ohio shall achieve compliance with paragraph (E) of rule 3745-21-09 of the Administrative Code by July 1, 1979, and paragraph (S) of rule 3745-21-09 of the Administrative Code by July 1, 1981.
- (21) "~~General Motors LLC - Lordstown Complex~~Lordstown Motors Corp.", facility ID 0278000199, or any subsequent owner or operator of the "~~General Motors LLC - Lordstown Complex~~Lordstown Motors Corp." automobile assembly plant located at 2200 Hallock Young road, Lordstown, Ohio shall achieve compliance with paragraph (C)(1)(a)(i) of rule 3745-21-09 of the Administrative Code by December 31, 1982; and paragraphs (C)(1)(a)(ii), (C)(1)(c) and (C)(1)(d) of rule 3745-21-09 of the Administrative Code by December 31, 1985.
- (22) "~~General Motors LLC - Lordstown Complex~~Lordstown Motors Corp.", facility ID 0278000199, or any subsequent owner or operator of the "~~General Motors LLC - Lordstown Complex~~Lordstown Motors Corp." light-duty truck assembly plant located at 2200 Hallock Young road, Lordstown, Ohio shall achieve compliance with paragraph (C)(1)(a)(i) of rule 3745-21-09 of the Administrative Code by December 31, 1982; and paragraphs (C)(1)(a)(ii), (C)(1)(c) and (C)(1)(d) of rule 3745-21-09 of the Administrative Code by December 31, 1984.
- (23) [Reserved.]
- (24) [Reserved.]

- (25) "Ford Motor Company - Ohio Assembly Plant", facility ID 0247030471, or any subsequent owner or operator of the "Ford Motor Company - Ohio Assembly Plant" light-duty truck assembly plant located at 650 ~~Miller road~~ Miller road, Avon Lake, Ohio shall achieve compliance with paragraph (C)(1)(a)(i) of rule 3745-21-09 of the Administrative Code by December 31, 1982; and paragraphs (C)(1)(a)(ii), (C)(1)(c) and (C)(1)(d) of rule 3745-21-09 of the Administrative Code by December 31, 1986.
- (26) [Reserved.]
- (27) Any owner or operator of petroleum refinery equipment which is subject to paragraph (T) of rule 3745-21-09 of the Administrative Code shall submit to the director a monitoring program by July 1, 1981, and the first quarterly monitoring report by October 15, 1981.
- (28) Miscellaneous metal part or product coating lines.
- (a) Except as otherwise provided in paragraphs (C)(28)(b) to (C)(28)(d) of this rule, any owner or operator of a miscellaneous metal part or product coating line which is subject to paragraph (U) of rule 3745-21-09 of the Administrative Code shall achieve compliance with said requirements by December 31, 1982.
- (b) Any owner or operator of a miscellaneous metal part or product coating line which employs a control system shall achieve compliance with either the control requirements specified in paragraph (B)(6) of rule 3745-21-09 of the Administrative Code or the applicable VOC limitation which is contained in paragraph (U) of rule 3745-21-09 of the Administrative Code and expressed in terms of pounds of VOC per gallon of solids by April 1, 1995.
- (c) Any owner or operator of a miscellaneous metal part or product coating line which is subject to paragraph (U)(1)(e) of rule 3745-21-09 of the Administrative Code, pertaining to the interior coating of a steel pail or drum, shall achieve compliance with said requirements by April 1, 1995.
- (d) Any owner or operator of a miscellaneous metal part or product coating line which is subject to paragraph (U)(2)(e)(i) of rule 3745-21-09 of the Administrative Code or which was, prior to January 17, 1995, subject to the 4.8 pounds VOC per gallon of coating limitation for anticorrosion coatings contained in rule 3745-21-09 of the Administrative Code, shall achieve compliance by January 17, 1996.

- (e) Any owner or operator of a miscellaneous metal part or product coating line which is located in Ashtabula, Butler, Clermont, Cuyahoga, Geauga, Hamilton, Lake, Lorain, Medina, Portage, Summit, or Warren county and which was, prior to June 15, 1999, subject to the ten gallons per day exemption contained under paragraph (U)(2)(e) of rule 3745-21-09 of the Administrative Code shall achieve compliance with paragraph (U)(1) or (U)(2)(e)(ii) of rule 3745-21-09 of the Administrative Code by June 15, 2000.
- (29) Any owner or operator of a gasoline tank truck which is subject to paragraph (V) of rule 3745-21-09 of the Administrative Code shall achieve compliance with said requirements by March 31, 1983.
- (30) Any owner or operator of a synthesized pharmaceutical manufacturing facility which is subject to paragraph (W) of rule 3745-21-09 of the Administrative Code shall achieve compliance with said requirements by December 31, 1982.
- (31) Any owner or operator of a pneumatic rubber tire manufacturing facility which is subject to paragraph (X) of rule 3745-21-09 of the Administrative Code shall achieve compliance with said requirements by December 31, 1982.
- (32) Any owner or operator of a packaging rotogravure printing line, publication rotogravure printing line, or flexographic printing line which is subject to the following:
- (a) Paragraph (Y)(1) of rule 3745-21-09 of the Administrative Code shall achieve compliance with said requirements by December 31, 1982.
- (b) Paragraph ~~(Y)(3)~~ (Y)(4) of rule 3745-21-09 of the Administrative Code shall achieve compliance with said requirements by no later than April 2, 2010 for a packaging rotogravure printing line, publication rotogravure printing line, or flexographic printing line located in Ashtabula, Cuyahoga, Geauga, Lake, Lorain, Medina, Portage, or Summit county.
- (c) Paragraph (Y)(4) of rule 3745-21-09 of the Administrative Code shall achieve compliance with said requirements by no later than March 1, 2023 for a packaging rotogravure printing line, publication rotogravure printing line, or flexographic printing line located in Butler, Clermont, Hamilton or Warren county.
- (33) Any owner or operator of an external floating roof tank which is subject to paragraph (Z) of rule 3745-21-09 of the Administrative Code shall achieve compliance with said requirements by December 31, 1982.

- (34) [Reserved.]
- (35) "Honda of America Mfg., Inc, Marysville Auto Plant.", facility ID 0180010193, or any subsequent owner or operator of the "Honda of America Mfg., Inc., Marysville Auto Plant" automobile assembly plant located at 24000 Honda Parkway (U.S. route 33), Marysville, Ohio shall achieve compliance with paragraphs (C)(1)(c) and (C)(1)(d) of rule 3745-21-09 of the Administrative Code by December 31, 1986.
- (36) Any owner or operator of a petroleum dry cleaning facility which is subject to paragraph (BB) of rule 3745-21-09 of the Administrative Code shall achieve compliance with said requirements by December 31, 1987.
- (37) Any owner or operator of a continuous, polystyrene resin manufacturing process which is subject to paragraph (CC) of rule 3745-21-09 of the Administrative Code shall achieve compliance with said requirements by December 31, 1987.
- (38) Except as otherwise provided in paragraph (C)(66) of this rule, any owner or operator of a process unit which produces organic chemicals and which is subject to paragraph (DD) of rule 3745-21-09 of the Administrative Code shall achieve compliance with paragraph (DD)(2) of rule 3745-21-09 of the Administrative Code by February 1, 1987, and paragraphs (DD)(3) to (DD)(6) of rule 3745-21-09 of the Administrative Code by July 1, 1987.
- (39) Except as otherwise provided in paragraph (C)(66) of this rule, any owner or operator of an air oxidation process which is subject to paragraph (EE) of rule 3745-21-09 of the Administrative Code shall achieve compliance with said requirements by December 31, 1987.
- (40) "~~Steelecrafft Manufacturing Company~~Schlage Lock Company LLC", facility ID 1431050879, or any subsequent owner or operator of "~~Steelecrafft Manufacturing Company~~Schlage Lock Company LLC" facility located at 9017 Blue Ash road, Cincinnati, Ohio shall achieve compliance with paragraph (FF)(1) of rule 3745-21-09 of the Administrative Code by April 1, 1989, and paragraph (FF) (2) of rule 3745-21-09 of the Administrative Code by April 1, 1989.
- (41) [Reserved.]
- (42) Any owner or operator of an automotive/transportation plastic parts coating line or a business machine plastic parts coating line which is subject to paragraph (HH) of rule 3745-21-09 of the Administrative Code shall achieve compliance with said requirements no later than August 25, 2009.
- (43) [Reserved.]

- (44) "OMNOVA Solutions Inc.", facility ID 1677010195, or any subsequent owner or operator of "OMNOVA Solutions Inc." facility located at 1380 Tech Way drive bldg 119, Akron, Ohio shall achieve compliance with paragraph (JJ) of rule 3745-21-09 of the Administrative Code by May 25, 1988.
- (45) ~~"PMC Cincinnati, Inc.", facility ID 1431380075, or any subsequent owner or operator of the "PMC Cincinnati, Inc." facility located at 2000 West street, Cincinnati, Ohio shall achieve compliance with paragraph (KK) of rule 3745-21-09 of the Administrative Code by May 25, 1988.~~[Reserved.]
- (46) "The Lubrizol Corporation", facility ID 0243000024, or any subsequent owner or operator of "The Lubrizol Corporation" facility located at 155 Freedom road, Painesville, Ohio shall achieve compliance with paragraph (LL) of rule 3745-21-09 of the Administrative Code by October 1, 1989.
- (47) "PPG Industries Ohio, Inc. ~~—Cleveland~~", facility ID 1318000101, or any subsequent owner or operator of the "PPG Industries Ohio, Inc. ~~—Cleveland~~" facility located at 3800 West 143rd street, Cleveland, Ohio shall achieve compliance with paragraph (MM) of rule 3745-21-09 of the Administrative Code by May 25, 1988.
- (48) "Von Roll ~~Isola~~ USA, Inc.", facility ID 1318002663, or any subsequent owner or operator of the "Von Roll ~~Isola~~ USA, Inc." facility located at 4853 West 130th street, Cleveland, Ohio shall achieve compliance with paragraph (NN) of rule 3745-21-09 of the Administrative Code no later than the deadlines in the following schedule:
- (a) For machine 30, by June 1, 1989.
- (b) For any machine other than machine 30, by December 31, 1989.
- (49) "AK Steel Corporation", facility ID 1409010006 or any subsequent owner or operator of the "AK Steel Corporation" facility located at 1801 Crawford street, Middletown, Ohio shall achieve compliance with paragraph (OO) of rule 3745-21-09 of the Administrative Code by March 31, 1993.
- (50) "Formica Corporation - Evandale", facility ID 1431150801, or any subsequent owner or operator of the "Formica Corporation - Evandale" facility located at 10155 Reading road, Cincinnati, Ohio shall achieve compliance with paragraph (PP) of rule 3745-21-09 of the Administrative Code by May 25, 1988.
- (51) "Day-Glo Color Corp.", facility ID 1318006552, or any subsequent owner or operator of the "Day-Glo Color Corp." facility located at 4515 St. Clair

avenue, Cleveland, Ohio shall achieve compliance with paragraph (QQ) of rule 3745-21-09 of the Administrative Code by May 1, 1994.

(52) [Reserved.]

(53) ~~"Ritrama Duramark", facility ID 1318007355, or any subsequent owner or operator of the "Ritrama Duramark" facility located at 341 Eddy Road, Cleveland, Ohio shall achieve compliance with paragraph (SS) of rule 3745-21-09 of the Administrative Code by March 31, 1993.~~[Reserved.]

(54) [Reserved.]

(55) "BP-Husky Refining LLC", facility ID 0448020007, or any subsequent owner or operator of the "BP-Husky Refining LLC" facility located at 4001 Cedar Point road, Oregon, Ohio shall achieve compliance with paragraph (UU)(1) of rule 3745-21-09 of the Administrative Code by May 1, 1995, paragraphs (UU)(2) and (UU)(3) of rule 3745-21-09 of the Administrative Code by May 1, 1993, paragraph (UU)(4) of rule 3745-21-09 of the Administrative Code by May 1, 1994, paragraph (UU)(5) of rule 3745-21-09 of the Administrative Code by October 1, 1993, and paragraph (UU)(6) of rule 3745-21-09 of the Administrative Code by January 1, 1995.

(56) "Marathon Petroleum Company LP - Canton Refinery", facility ID 1576002006, or any subsequent owner or operator of the "Marathon Petroleum Company LP - Canton Refinery" facility located at 2408 Gambrinus road, S.W., Canton, Ohio shall achieve compliance with paragraph (VV) of rule 3745-21-09 of the Administrative Code by March 31, 1993.

(57) [Reserved.]

(58) [Reserved.]

(59) "PMC Specialties Group", facility ID 1431390137, or any subsequent owner or operator of the "PMC Specialties Group" facility located at 501 Murray road, Cincinnati, Ohio shall achieve compliance with paragraph (YY)(1) of rule 3745-21-09 of the Administrative Code by March 31, 1993, and paragraph (YY)(2) of rule 3745-21-09 of the Administrative Code by May 1, 1994.

(60) "Firestone Polymers", facility ID 1677010000, or any subsequent owner or operator of the "Firestone Polymers" facility located at 381 West Wilbeth road, Akron, Ohio shall achieve compliance with paragraph (ZZ) of rule 3745-21-09 of the Administrative Code by May 1, 1994.

(61) [Reserved.]

- (62) "~~Emerald Performance Materials, LLC~~Huntsman Advanced Materials Americas, LLC", facility ID 1677010029, or any subsequent owner or operator of the "~~Emerald Performance Materials, LLC~~Huntsman Advanced Materials Americas, LLC" facility located at 240 West Emerling avenue, Akron, Ohio shall achieve compliance with paragraph (BBB)(1) of rule 3745-21-09 of the Administrative Code by August 15, 1993, and paragraphs (BBB)(2) to (BBB)(4) of rule 3745-21-09 of the Administrative Code by December 15, 1994.
- (63) [Reserved.]
- (64) Any owner or operator of a gasoline dispensing facility which is subject to paragraph (DDD) of rule 3745-21-09 of the Administrative Code shall achieve compliance with said requirements no later than the following deadlines:
- (a) For any gasoline dispensing facility not owned by an independent small business marketer:
 - (i) For any gasoline dispensing facility for which construction commenced after November 15, 1990 and prior to March 31, 1993, by September, 1993.
 - (ii) For any gasoline dispensing facility which dispenses at least one hundred thousand gallons of gasoline per month (based upon the average monthly sales of gasoline during the period from November 16, 1990 through November 15, 1992), by March 31, 1994.
 - (iii) For any other gasoline dispensing facility not covered by paragraphs (C)(64)(a)(i) and (C)(64)(a)(ii) of this rule, by March 31, 1995.
 - (b) For gasoline dispensing facilities owned by independent small business marketers:
 - (i) For a minimum of thirty-three per cent of the gasoline dispensing facilities owned by each such marketer, by March 31, 1994.
 - (ii) For a minimum of sixty-six per cent of the gasoline dispensing facilities owned by such marketer, by March 31, 1995.
 - (iii) For one hundred per cent of the gasoline dispensing facilities owned by each such marketer, by March 31, 1996.
- (65) Any owner or operator of an air contaminant source which is located in Ashtabula, Clark, Delaware, Geauga, Licking, or Miami county and which,

prior to March 31, 1993, was exempt from paragraphs (C) to (M), (O) to (R), (T), (U), and (W) to (EE) of rule 3745-21-09 of the Administrative Code because the facility's potential to emit is less than one hundred tons of VOC per calendar year, shall achieve compliance with said requirements by April 1, 1995.

- (66) "Georgia Pacific Chemicals LLC", facility ID 0125040904, or any subsequent owner or operator of the "Georgia Pacific Chemicals LLC" facility located at 1975 Watkins road, Columbus, Ohio shall achieve compliance with paragraphs (DD) and (EE) of rule 3745-21-09 of the Administrative Code for the process unit which produces urea-formaldehyde by May 1, 1994.

Effective: 3/27/2022
Five Year Review (FYR) Dates: 11/29/2021 and 11/29/2026

CERTIFIED ELECTRONICALLY

Certification

03/17/2022

Date

Promulgated Under: 119.03
Statutory Authority: 3704.03(E)
Rule Amplifies: 3704.03(A), 3704.03(E)
Prior Effective Dates: 07/28/1975, 10/19/1979, 03/27/1981, 06/21/1982,
01/24/1983, 05/09/1986, 05/25/1988, 08/22/1990,
03/31/1993, 01/17/1995, 06/15/1999, 11/05/2002,
02/10/2006, 08/25/2008, 04/02/2009, 08/26/2011,
10/15/2015

3745-21-07

Control of emissions of organic materials from stationary sources (i.e., emissions that are not regulated by rule 3745-21-09, 3745-21-12 to 3745-21-16, or 3745-21-18 to 3745-21-29 of the Administrative Code).

[Comment: For dates and availability of non-regulatory government publications, publications of recognized organizations and associations, federal rules, and federal statutory provisions referenced in this rule, see paragraph (JJ) of rule 3745-21-01 of the Administrative Code titled "referenced materials."]

(A) Applicability.

(1) [Reserved]

(2) [Reserved]

(3) This rule shall apply to any source or operation, for which installation commenced prior to February 18, 2008 and that is specified in paragraphs (K) to (N) of this rule, but ~~shall not apply~~ is not applicable to VOC emissions from any such source or operation that are regulated by rule 3745-21-09, 3745-21-12 to 3745-21-16, or 3745-21-18 to 3745-21-29 of the Administrative Code. Any owner or operator of any subject source or operation specified in paragraphs (K) to (N) of this rule shall comply with the facility-specific and general control requirements of this rule as of February 18, 2008.

(4) Any emission limitation, control requirement, or operational restriction contained in a permit-to-install, permit-by-rule, permit-to-operate, or Title V permit that is based upon a citation to this rule, except the emission limitations and control requirements specified in paragraphs (K)(2), (K)(4), (L)(2), (M)(2) to (M)(4), (N)(2), and (N)(3) of this rule, ~~shall be void upon~~ expire as of February 18, 2008.

[Comment: As examples of the applicability of this paragraph, if a permit-to-install, a permit-by-rule, a permit-to-operate, or a Title V permit has been issued prior to February 18, 2008 and contains both a citation to rule 3745-21-07 of the Administrative Code and one of the associated requirements referenced within this comment, the associated requirements contained in such a permit ~~shall be void upon~~ expire as of February 18, 2008. The associated requirements covered by this comment ~~shall~~ include: (a) any requirement that prohibits the use of photochemically reactive materials, or prohibits the use of volatile photochemically reactive materials; (b) any requirement that limits organic compound emissions from an operation to eight pounds per hour and forty pounds per day, except as specified in paragraphs (M)(3)(d) and (M)(3)(g) of this rule; (c) any requirement to determine or document materials as being photochemically reactive materials; and (d) any recordkeeping and reporting

requirements related to requirements referred to in (a), (b) or (c) of this comment.

All other permit conditions, including annual emission or material usage limitations (tons per year, gallons per day or month or year, VOC per gallon, etc.) and all other recordkeeping and reporting requirements associated with those permit conditions remain in effect.]

- (5) This rule ~~shall~~does not apply to any source, including any new source as defined in rule 3745-15-01 of the Administrative Code, for which installation commenced after February 18, 2008.
- (6) For any source or operation specified in paragraphs (K) to (N) of this rule that is subject to a mass emission rate, control efficiency, overall control efficiency, or emission reduction, the owner or operator shall determine compliance by means of one of the following:
- (a) For controlled and uncontrolled sources, the test methods and procedures of paragraphs (A) to (C) of rule 3745-21-10 of the Administrative Code; or
 - (b) An emission factor approved by the USEPA, such as an emission factor from the "Compilation of Air Pollutant Emission Factors, Volume 1: Stationary Point and Area Sources (AP-42)."
 - (c) Emissions test data from similar sources or operations, provided such emissions tests comply with the test methods and procedures of paragraphs (B) and (C) of rule 3745-21-10 of the Administrative Code, and the USEPA has indicated in writing that the use of such tests is acceptable.

The use of emissions test data, if available, from a source or operation specified in paragraphs (K) to (N) of this rule ~~shall~~ take precedence over the use of an emission factor approved by the USEPA or the use of emission test data from similar sources or operations.

(B) [Reserved.]

(C) [Reserved.]

(D) [Reserved.]

(E) [Reserved.]

(F) [Reserved.]

(G) [Reserved.]

(H) [Reserved.]

(I) [Reserved.]

(J) [Reserved.]

(K) Facility-specific control requirements for storage tanks (stationary tank, reservoir, or other container):

- (1) The owner or operator, or any subsequent owner or operator of each storage tank identified in this paragraph, shall comply with the control requirements specified in paragraph (K)(2) of this rule:

(K)(1) Emissions Units

Owner or Operator	Facility ID	Emissions Unit ID
Akzo Nobel Coatings, Inc.	0322000043	T009, T025 - T029, T042, T044, T045, T049, T052, T053, T063 - T065, T067, T074, T076
Marathon Petroleum Company LP <u>MPLX Terminals LLC</u> - Brecksville Terminal	1318082830	T004

- (2) No person shall place, store or hold in any storage tank identified in paragraph (K)(1) of this rule, any liquid organic material that has a vapor pressure of 1.5 pounds per square inch absolute or greater, under actual storage conditions, unless the storage tank is equipped with one of the following vapor loss control equipment:

- (a) ~~The storage tank shall be equipped with a~~ A floating pontoon or double-deck type cover that includes closure seals to enclose any space between the cover's edge and the compartment wall. ~~This control requirement shall not be permitted if~~ provided that the liquid organic material in the tank has a vapor pressure of less than 12.5 pounds per square inch absolute ~~or greater~~ under actual storage conditions. ~~All and all~~ tank gauging or sampling devices ~~shall be~~ remain gas tight except when tank gauging or sampling is taking place.

(b) ~~The storage tank shall be equipped with a~~ A vapor recovery system or control system that reduces the emission of organic compounds into the atmosphere by at least ninety per cent by weight. ~~At and all~~ tank gauging or sampling devices ~~shall be~~ remain gas tight except when tank gauging or sampling is taking place.

(3) The owner or operator, or any subsequent owner or operator of each storage tank (stationary storage vessel) identified in this paragraph, shall comply with the control requirements specified in paragraph (K)(4) of this rule:

(K)(3) Emissions Units

Owner or Operator	Facility ID	Emissions Unit ID
GE Lighting, Ivanhoe Road <u>Current Lighting Solutions -Ivanhoe</u>	1318000156	T012, T013
Buckeye Terminals, LLC, Cleveland Plant	1318002740	T011, T012
Tremco, Inc. - Mameco Division	1318002813	T021, T023, T036-T041
Hukill Chemical Corporation <u>Ohio Reclamation and Waste Services, LLC</u>	1318030172	T063-T070, T077-T081, T083, T089-T093, T095-T097, T100
Marathon Petroleum Company LP <u>MPLX Terminals LLC - Brecksville Terminal</u>	1318082830	T004, T018
Rochling Glastic Composites	1318544510	T009

(4) No person shall place, store or hold in any storage tank identified in paragraph (K)(3) of this rule, any liquid organic material that has a vapor pressure of 1.5 pounds per square inch absolute or greater, under actual storage conditions, unless the storage tank is equipped with a permanent submerged fill pipe, or is loaded through the use of a portable loading tube which can be inserted below the liquid level line during loading operations, or is fitted with a vapor recovery system as described in paragraph (K)(2)(b) of this rule.

(L) Facility-specific control requirements for oil-water separators (effluent water separators):

- (1) The owner or operator, or any subsequent owner or operator of each oil-water separator identified in this paragraph, shall comply with the control requirements specified in paragraph (L)(2) of this rule:

(L)(1) Emissions Units

Owner or Operator	Facility ID	Emissions Unit ID
Marathon Ashland Petroleum, LLC <u>CLOWMPLX Terminals LLC - Columbus Terminal</u>	0125040071	P002

- (2) No person shall use any oil-water separator identified in paragraph (L)(1) of this rule that recovers any liquid organic material which has a vapor pressure of 1.5 pounds per square inch absolute or greater unless the oil-water separator complies is equipped with one of the following:

- (a) ~~The oil-water separator shall be equipped with a~~ solid cover with all openings sealed and totally enclosing the liquid contents of the compartment. ~~All and all~~ gauging and sampling devices ~~shall be~~ remaining gas tight except when gauging or sampling is taking place.
- (b) ~~The oil-water separator shall be equipped with a~~ floating pontoon or double-deck type cover that includes closure seals to enclose any space between the cover's edge and compartment wall. ~~All and all~~ gauging and sampling devices ~~shall be~~ remaining gas tight except when gauging or sampling is taking place.
- (c) ~~The oil-water separator shall be equipped with a~~ vapor recovery system that reduces the emission of organic compounds into the atmosphere by at least ninety per cent by weight. ~~All and all~~ gauging and sampling devices ~~shall be~~ remaining gas tight except when gauging or sampling is taking place.

- (M) Facility-specific and general control requirements for emissions from operations using liquid organic materials:

- (1) The owner or operator, or any subsequent owner or operator of each article, machine, equipment or other contrivance identified in this paragraph, shall comply with the control requirements specified in paragraph (M)(2) of this rule:

(M)(1) Emissions Units

Owner or Operator	Facility ID	Emissions Unit ID
Akzo Nobel Coatings, Inc.	0125040064	J002, P001, P002, P201-P224, P226-P262, P275-P291, P305-P308, P310-P313, P315-P325, P365-P370
Plaskolite, Inc. <u>LLC.</u>	0125040915	P013-P015, P013, P014, P042, P052, R001, R003, R004
Core Molding Technologies, Inc.	0125041046	P007
Clean Harbors Recycling Services of Ohio L.L.C.	0145020235	P001, P003-P011, P013, P016
Stanley Electric US Company	0149000089	R022, R023
Maseo Cabinetry <u>Cabinetworks Group</u> Middlefield LLC (KraftMaid Plant #1)	0228000186	K001-K019
Henkel Consumer Adhesives, <u>Inc.</u> <u>US Operations Corporation</u>	0243081155	P001, P002, P012, P015
The Kennedy Group	0243081245	K001
The Lubrizol Corporation, ; Wickliffe Facility	0243150025	P011, P012
Lubrizol Advanced Materials	0247030004	P007, P008
A.R.E <u>Accessories, LLC</u> , Inc., Mt. Eaton Facility	0285000291	R004-R007, R012-R014, R016
Akzo Nobel Coatings, Inc.	0322000043	P009-P022
Guardian Manufacturing <u>Company</u>	0339030016	P801, P802, P804
Continental Structural Plastics	0387000042	R012-R015
Norplas Industries, Inc.	0387000362	R001
Continental Structural Plastics	0388000002	R009

Decorative Panels International, Inc.	0448011193	K001
Klinger Thermoseal, Inc.	05750101610375	P005, 61
Turf Care Supply Corp. - Martins Ferry Plant	0607090125	F005-F007
Maseo Cabinetry, Merrillat, Jackson Speyside Bourbon Cooperage, Inc.	0640010020	K002, K003, R007
Kraton Polymers U.S., LLC	0684010011	P004 (wet end only), P006 (wet end only), P007 (wet end only), P010 (wet end only)
BASF Corporation	0819070134	P001, P008-P010, P013-P016, P021-P025, P028, P029, P031
Greenville Technologies Technology, Inc.	0819070190	R001-R003
Florida Production Engineering	0819100218	K001
Dupont Electronic Polymers, LP	0857040727	P025 (in methylene chloride service only), P027 (in methylene chloride service only)
Aptalis Pharmatech, Inc. <u>Adare Pharmaceuticals, Inc.</u>	0857171794	P001, P008, P012, P014, P015, P017, P019, P020
Neaton Auto Products Manufacturing, Inc.	0868030155	K016, R003
Rohm and Haas Chemicals, LLC <u>DDP Specialty Electronic Materials US 5, LLC</u>	0868090072	P505-P507, P509-P511, P520, P521, P524
Day-Glo Color Corp.	1318006552	P001, P002, P008, P009, P021, P024, P026, P027, P030
Polymers Additives, Inc. <u>Valtris Specialty Chemicals</u>	1318030264	P027, P034

Ineos ABS (USA) Corporation	1431010054	P001, P010, P022, P048 , P036, P042, P047, P048
H.B. Fuller Company Co.	1431052206	P007, P008
Givaudan Flavors Corporation	1431070914	P020
Richard Miller Water Treatment Plant	1431072596	N004, N005
Spring Grove Resource Recovery <u>Inc</u>	1431072600	J001, T008-T011, P016
Environmental Enterprises	1431072690	P002
Nease Corporation Co. LLC	1431111828	P011, P012, P024, P026-P028, P801, P803
PMC Specialties <u>Group</u> , Inc.	1431390137	P006, P008, P010, P011, P014, P901
Flint Group Pigments	1431483219	P001-P005
A.R.E., Inc., Massillon Accessories, LLC	1576131793	K001-K004, P001-P003, P010, P011, T001, T002
Schneller, Inc. LLC	1667040015	K005
Emerald Performance Materials, LLC Huntsman Advanced Materials Americas, LLC	1677010029	P007
PPG Industries, - South Plant	1677020162	P099
PPG Industries, - Teslin Plant	1677020164	P110, P114, P115
<u>Avery Dennison STD, Bldg 5</u>	<u>0243111362</u>	<u>P071 (distillation unit emissions only)</u>
<u>TRC Buyer Co. dba "The Ruscoe Company" Plant II</u>	<u>1677010204</u>	<u>P025, P026, P028, P030, P031, P032, P033, P034, P035, P036</u>

- (2) Each article, machine, equipment or other contrivance identified in paragraph (M)(1) of this rule, or meeting paragraph (M)(3)(a) of this rule, shall be equipped with a control system (i.e., capture and control equipment) that reduces the

organic compound emissions from the article, machine, equipment or other contrivance by an overall control efficiency of at least eighty-five per cent, by weight. If the reductions are achieved by incineration, ninety per cent or more of the carbon in the organic material being incinerated shall be oxidized to carbon dioxide.

(3) Other operations using liquid organic materials.

(a) Any article, machine, equipment or other contrivance that meets all of the following conditions shall comply with the control requirements specified in paragraph (M)(2) of this rule:

(i) Is an existing source located within a "Priority I" county, as identified in rule 3745-21-06 of the Administrative Code, or a new source, as defined in rule 3745-15-01 of the Administrative Code, regardless of location.

(ii) Commenced installation prior to February 18, 2008.

(iii) Uses a liquid organic material or a substance containing a liquid organic material.

(iv) Is equipped with control equipment for organic compound emissions.

(v) The emissions are not subject to control requirements specified in rule 3745-21-09, 3745-21-12 to 3745-21-16, or 3745-21-18 to 3745-21-29 of the Administrative Code.

(vi) Is not specified in paragraph (K)(1), (K)(3), (L)(1), (M)(1) or (N)(1) of this rule.

(vii) Does not meet any of the conditions specified under paragraph (M)(3)(c) of this rule.

(viii) Is not specified in paragraph (M)(3)(d) of this rule.

(ix) Is not fuel burning equipment, as defined in rule 3745-17-01 of the Administrative Code.

(b) The owner or operator of any article, machine, equipment, or other contrivance meeting paragraph (M)(3)(a) of this rule, and not specified in paragraph (M)(1) of this rule, shall notify Ohio EPA by May 18, 2008 of the need to be specified in paragraph (M)(1) of this rule. ~~Such notification shall be submitted by May 18, 2008.~~

- (c) Any article, machine, equipment or other contrivance that meets any of the following conditions shall not be subject to paragraphs (M)(3)(a) and (M)(3)(b) of this rule:
- (i) The article, machine, equipment, or other contrivance commenced installation after February 18, 2008.
 - (ii) The uncontrolled potential to emit for organic compound emissions from the article, machine, equipment or other contrivance does not exceed forty pounds per day where uncontrolled potential to emit for organic compound emissions means the capability at maximum capacity of an article, machine, equipment or other contrivance to emit organic compounds under its physical and operational design. Any physical or operational limitation on the capability of an article, machine, equipment or other contrivance to emit organic compounds, including restrictions on the hours of operation or on the type or amount of material processed, but not including restrictions pertaining to air pollution control equipment, shall be treated as part of its physical and operational design if the limitation or the effect it would have on organic compound emissions is federally enforceable or legally and practicably enforceable by the state.
 - (iii) The article, machine, equipment or other contrivance is subject to and complying with a best available technology requirement, pursuant to rule 3745-31-05 of the Administrative Code, that specifies an overall control efficiency for organic compound or VOC emissions that is greater than eighty-five per cent, by weight.
 - (iv) The article, machine, equipment or other contrivance is subject to and complying with a federal regulation that specifies an overall control efficiency for organic compound or VOC emissions that is greater than eighty-five per cent, by weight.
 - (v) The article, machine, equipment or other contrivance is subject to and complying with paragraph (M)(3)(g) or (M)(4) of this rule.
 - (vi) The article, machine, equipment or other contrivance is a heatset web offset printing line that is subject to and complying with a best available technology requirement, pursuant to rule 3745-31-05 of the Administrative Code, that specifies the dryer to be equipped with a control device having either a control efficiency for organic compound or VOC emissions that is equal to or greater than ninety

per cent, by weight, or an outlet concentration of less than twenty parts per million, by volume, dry basis for organic compound or VOC emissions (a heatset web offset printing line is an offset lithographic printing line in which the substrate is continuously fed from a roll and a heated oven is used to dry the printing inks).

(vii) The article, machine, equipment or other contrivance is regulated by and complying with Chapter 3745-76 of the Administrative Code.

(d) The following specific articles, machines, equipment or other contrivances ~~shall not be subject to~~ are exempt from paragraphs (M)(3)(a) and (M)(3)(b) of this rule:

(i) Any emissions unit identified in paragraphs (M)(3)(d)(ii) to (M)(3)(d)(ix) of this rule that obtains an alternative emission limitation or control requirement pursuant to paragraph (M)(5)(e) of this rule.

(ii) Emissions unit R001 at the "Dee Sign Company" (facility ID 1409000675), provided that the organic compound emissions from the emissions unit are controlled by means of a thermal incinerator that maintains an overall control efficiency of at least 74.1 per cent, by weight, in accordance with permit-to-install 14-2185.

(iii) Emissions units P001, P002, P003, P004, P007, P008, P009 and P010 at "3M Elyria" (facility ID 0247040822), provided that the organic compound emissions from the emissions units are controlled by means of a packed bed scrubber and biofiltration system that maintain an overall control efficiency of at least eighty per cent, by weight, in accordance with permit-to-install 02-13356.

(iv) Emissions unit P001 at "Fort Amanda Specialties, LLC" (facility ID 0302020097), provided that the organic compound emissions from the emissions unit are controlled by means of a packed bed scrubber that limits emissions to 0.04 pounds per hour, in accordance with permit-to-install 03-5696.

(v) The following emissions units at "Franklin International" (facility ID 0125040070), provided that all the emissions units are controlled by a condenser that limits the VOC emissions as specified:

(a) For emissions unit P103, eight pounds per hour and forty pounds per day.

- (b) For emissions unit P106, 6.5 pounds per hour and 32.3 pounds per day, in accordance with permit-to-install 01-05683.
 - (c) For emissions unit P107, 6.5 pounds per hour and 32.3 pounds per day, in accordance with permit-to-install 01-05683.
 - (d) For emissions unit P113, eight pounds per hour and forty pounds per day.
 - (e) For emissions unit P114, eight pounds per hour and forty pounds per day.
 - (f) For emissions unit P115, 7.3 pounds per hour and 32.3 pounds per day, in accordance with permit-to-install 01-08402.
 - (g) For emissions unit P116, 6.5 pounds per hour and 32.3 pounds per day, in accordance with permit-to-install 01-05683.
 - (h) For emissions unit P124, 4.38 pounds per hour and 21.92 pounds per day, in accordance with permit-to-install 01-05232.
 - (i) For emissions unit P125, 7.8 pounds per hour and 39.0 pounds per day, in accordance with permit-to-install 01-06303.
 - (j) For emissions unit P127, 6.92 pounds per hour and 32.3 pounds per day, in accordance with permit-to-install 01-08402.
- (vi) Emissions unit R201 at "Honda of America Mfg., Inc., Marysville Auto Plant" (facility ID 0180010193), provided that this emissions unit is equipped with capture and control equipment that provide not less than an eighty-one per cent reduction, by weight, in the overall organic compound emissions from the application and drying of plastic part coatings within this emissions unit. For any reductions that are achieved by incineration, the incineration equipment shall provide not less than ninety per cent, by weight, destruction (control) efficiency.
- (vii) [Reserved.]
- (viii) [Reserved.]
- (ix) Emissions unit P080 at "~~PPG Industries, -~~ North Plant" (facility ID 1677020163), provided that the organic compound emissions are limited to less than forty pounds per day and are controlled by a

flare or other control device when necessary to limit emissions to less than forty pounds per day, in accordance with permit-to-install 16-1102.

- (e) "Cooper Standard Automotive, LLC" (facility ID 0387020045) or any subsequent owner or operator of the "Cooper Standard Automotive, LLC" facility located at "1175 North Main Street, Bowling Green, Ohio" shall not cause, allow or permit the discharge into the ambient air of any VOC from flock line number 2, 3, or 4 (emissions units P078, P079 and P080 in accordance with permit-to-install P0111501) unless the VOC content of the adhesive or other coating employed within said flock line does not exceed 2.6 pounds of VOC per gallon of coating, excluding water and exempt solvents (as applied).
 - (f) [Reserved.]
 - (g) Except as provided in paragraphs (M)(3)(h) and (M)(5) of this rule, this paragraph applies to all existing sources located within a "Priority I" county, as identified in rule 3745-21-06 of the Administrative Code, and to all new sources, as defined in rule 3745-15-01 of the Administrative Code, regardless of location, for which installation commenced prior to February 18, 2008. The owner or operator, or any subsequent owner or operator of each sheet molding compound manufacturing operation shall not discharge from such operation more than forty pounds of organic materials into the atmosphere in any one day, nor more than eight pounds in any one hour, unless said discharge has been reduced by at least eighty-five per cent, by weight. If the reductions are achieved by incineration, ninety per cent or more of the carbon in the organic material being incinerated shall be oxidized to carbon dioxide. A sheet molding compound manufacturing operation is defined as a process which involves the production of a molding compound, that contains a resin, into sheet form. In this manufacturing operation, the molding compound is sandwiched between top and bottom films.
 - (h) [Reserved.]
- (4) Except as provided in paragraph (M)(5) of this rule, this paragraph applies to all existing sources located within a "Priority I" county, as identified in rule 3745-21-06 of the Administrative Code, and to all new sources, as defined in rule 3745-15-01 of the Administrative Code, regardless of location, for which installation commenced prior to February 18, 2008. The owner or operator, or any subsequent owner or operator of each article, machine, equipment or other contrivance in which any liquid organic material or substance containing liquid

organic material comes into contact with flame or is baked, heat-cured, or heat-polymerized, in the presence of oxygen, and is not specified in paragraph (M)(1) of this rule, shall not discharge from such source more than fifteen pounds of organic materials into the atmosphere in any one day, nor more than three pounds in any one hour, unless said discharge has been reduced by at least eighty-five per cent, by weight. If the reductions are achieved by incineration, ninety per cent or more of the carbon in the organic material being incinerated shall be oxidized to carbon dioxide.

(5) Exemptions.

- (a) Paragraph (M)(2) of this rule ~~shall~~does not apply to the use of any cleanup material in any article, machine, equipment, or other contrivance described in paragraph (M)(2) of this rule.
- (b) Paragraphs (M)(2), (M)(3)(a) and (M)(4) of this rule ~~shall~~do not apply to the emission from any material used in any article, machine, equipment or other contrivance described in paragraphs (M)(2), (M)(3)(a) and (M)(4) of this rule if the emission is not a VOC.
- (c) Paragraph (M)(2) of this rule ~~shall~~does not apply to the use, in any article, machine, equipment or other contrivance described in paragraph (M)(2) of this rule, of liquid organic materials which exhibit a boiling point higher than two hundred degrees Fahrenheit at 0.5 millimeter mercury absolute pressure, or having an equivalent vapor pressure, unless such liquid organic material is exposed to temperatures exceeding two hundred twenty degrees Fahrenheit.
- (d) Paragraphs (M)(1), (M)(2), (M)(3)(a) and (M)(4) of this rule ~~shall~~do not apply if either of the following occurs:
 - (i) The volatile content of the material used in any article, machine, equipment, or other contrivance described in paragraph (M)(1), (M)(2), (M)(3)(a) or (M)(4) of this rule consists only of water and liquid organic material, and the liquid organic material comprises not more than twenty per cent, by volume, of said volatile content.
 - (ii) The volatile content of the material used in any article, machine, equipment, or other contrivance described in paragraph (M)(1), (M)(2), (M)(3)(a) or (M)(4) of this rule does not exceed twenty per cent by volume of said material.

- (e) Paragraphs (M)(2), (M)(3)(d), (M)(3)(e), (M)(3)(f), (M)(3)(g), (M)(3)(h) and (M)(4) of this rule ~~shall~~do not apply if all the following conditions are met:
- (i) The director has determined that requirements equivalent to best available technology for the article, machine, equipment or other contrivance is a control requirement or emission limitation that is either less stringent than or inconsistent with paragraph (M) of this rule. ~~The~~ provided the equivalent best available technology requirement ~~shall be~~is consistent with division (F) of section 3704.01 of the Revised Code, equivalent to best available technology under rule 3745-31-05 of the Administrative Code and, for purposes of this paragraph, ~~shall provide~~provides, where a control requirement or emission limitation is applicable, the lowest emission limitation that the article, machine, equipment or other contrivance is capable of meeting by the application of control technology that is reasonably available considering technological and economic feasibility. ~~Also, and,~~ for an article, machine, equipment or other contrivance located within an ozone nonattainment area, the best available technology determination ~~must comply~~complies with Section 193 of the Clean Air Act amendments of 1990, general savings clause.
 - (ii) The USEPA has informed the Ohio EPA, in writing, prior to the issuance of a final permit-to-install for the article, machine, equipment or other contrivance, that the USEPA has no objection to the issuance of the final permit and the control requirement or emission limitation specified therein.
 - (iii) A final permit-to-install has been issued for the article, machine, equipment or other contrivance pursuant to Chapter 3745-31 of the Administrative Code. ~~The permit-to-install shall contain~~containing terms and conditions that are consistent with the approval granted by the USEPA pursuant to paragraph (M)(5)(e)(ii) of this rule, and that specify the control requirement or emission limitation that is the basis for the director's best available technology determination for the article, machine, equipment or other contrivance, as described in paragraph (M)(5)(e)(i) of this rule. ~~The permit-to-install shall be~~and that is issued by the Ohio EPA in a manner that makes the control requirement or emission limitation federally enforceable.

- (f) Paragraph (M) of this rule ~~shall~~does not apply to the emissions resulting from the use of any liquid organic materials in any article, machine, equipment or other contrivance if those emissions are regulated by rule 3745-21-09, 3745-21-12 to 3745-21-16, or 3745-21-18 to 3745-21-29 of the Administrative Code.
- (g) Paragraphs (M)(3)(a), (M)(3)(b), (M)(3)(g) and (M)(4) of this rule ~~shall~~do not apply to sources that are located in Darke, Fairfield, Madison, Perry, Pickaway, Preble or Union county and that are within a facility having the potential to emit not more than one hundred tons of organic compounds per calendar year.
- (h) Paragraph (M)(3)(g) of this rule ~~shall~~does not apply to any sheet molding compound manufacturing operation (machine) in which all of the following requirements are met:
- (i) The resin delivery system to the doctor box on the sheet molding compound manufacturing machine must be closed or covered (the doctor box itself may be open). A doctor box is defined as the box or trough on a sheet molding compound manufacturing machine into which the liquid resin paste is delivered before it is metered onto the carrier film.
 - (ii) A nylon containing film must be used to enclose the sheet molding compound.
- (i) Paragraph (M)(2) of this rule ~~shall~~does not apply to the use of a phenolic urethane cold box resin binder system in foundry core-making and mold-making operations, provided the catalyst gas emissions are vented to a control device that is designed and operated to remove at least ninety-eight per cent, by weight, of the catalyst gas emissions or maintain a maximum catalyst gas outlet concentration of one ppmv on a dry basis, whichever is less stringent. (In a phenolic urethane cold box resin binder system, sand is mixed with a two-part liquid urethane resin binder, and a catalyst gas is blown into the resin-coated sand to cause hardening.)
- (j) Paragraph (M)(2) of this rule does not apply to the use of a phenolic urethane no-bake resin binder system in foundry core-making and mold-making operations. (In a phenolic urethane no-bake resin binder system, sand is mixed with a two-part liquid urethane resin binder and a liquid catalyst, which regulates the speed of the resin curing reaction.)

~~(j)~~(k) The owner or operator of an article, machine, equipment or other contrivance that is exempt per paragraph (M)(5)(d) of this rule shall maintain the following records for all materials used:

- (i) The name and identification number of each liquid organic material.
- (ii) The composition of each material including the volatile content by volume per cent, the volume per cent of liquid organic material and the volume per cent of water. If exempt because of paragraph (M)(5)(d)(i) of this rule then the liquid organic material content, except water, relative to the volatile content (per cent by volume) or, if exempt because of paragraph (M)(5)(d)(ii) of this rule, the volatile content relative to the total material (per cent by volume).
- (iii) All time periods (beginning and ending dates and times) for each material that is exempt per paragraph (M)(5)(d) of this rule.

(N) Facility-specific control requirements for waste gas flare systems:

- (1) The owner or operator, or any subsequent owner or operator, of each waste gas flare system identified in this paragraph shall comply with the control requirements specified in paragraph (N)(2) of this rule:

(N)(1) Emissions Units

Owner or Operator	Facility ID	Emissions Unit ID
City of Urbana	0511010123 <u>0111010123</u>	P001

- (2) The waste gas flare system identified in paragraph (N)(1) of this rule shall employ a smokeless flare or equally effective control equipment for organic compound emissions.
- (3) "Meggitt Aircraft Braking Systems Corp." (facility ID 1677010999) or any subsequent owner or operator of the "Aircraft Braking Systems Corp." facility located at "1204 Massillon Road, Akron, Ohio" shall not emit a waste gas stream into the atmosphere from emissions units P036, P037, P038, P039, P040, P041, and P044 unless such waste gas stream is properly burned at 1300 degrees Fahrenheit for 0.3 seconds or greater in a direct-flame afterburner or equally effective control device for organic compound emissions.

Effective: 3/27/2022
Five Year Review (FYR) Dates: 11/29/2021 and 11/29/2026

CERTIFIED ELECTRONICALLY

Certification

03/17/2022

Date

Promulgated Under: 119.03
Statutory Authority: 3704.03(E)
Rule Amplifies: 3704.03(A), 3704.03(E)
Prior Effective Dates: 02/15/1972, 10/19/1979, 10/31/1996, 06/15/1999,
02/18/2008, 04/08/2016

3745-21-09

Control of emissions of volatile organic compounds from stationary sources and perchloroethylene from dry cleaning facilities.

[Comment: For dates and availability of non-regulatory government publications, publications of recognized organizations and associations, federal rules, and federal statutory provisions referenced in this rule, see paragraph (JJ) of rule 3745-21-01 of the Administrative Code titled "referenced materials."]

(A) Applicability.

(1) In Ashtabula, Butler, Clark, Clermont, Cuyahoga, Delaware, Franklin, Geauga, Greene, Hamilton, Lake, Licking, Lorain, Lucas, Mahoning, Medina, Miami, Montgomery, Portage, Stark, Summit, Trumbull, Warren and Wood counties, paragraphs ~~(E)~~(D) to (M), (O)(2)(a) to (O)(2)(d), (O)(3) to (O)(6), (P) to (R), (T), and (W) to (EE) of this rule shall apply to all sources regardless of date of construction or modification.

(2) Paragraphs (N) and (V) of this rule shall apply state-wide.

(3) For sources located in counties not listed in paragraph (A)(1) of this rule:

(a) Paragraphs ~~(E)~~(D) to (M), (O)(2)(a) to (O)(2)(d), (O)(3) to (O)(6), and (P) to (R) of this rule shall apply to all sources that meet either of the following:

(i) For which the construction or modification commenced on or after October 19, 1979.

(ii) Which are located at a facility having the potential to emit a total of one hundred tons or more of VOC per calendar year.

(b) Paragraphs (T), and (W) to (AA) of this rule shall apply to all sources that meet either of the following:

(i) For which the construction or modification commenced on or after March 27, 1981.

(ii) Which are located at a facility having the potential to emit a total of one hundred tons or more of VOC per calendar year.

(c) Paragraphs (BB) to (EE) of this rule shall apply to all sources that meet either of the following:

(i) For which the construction or modification commenced on or after May 9, 1986.

- (ii) Which are located at a facility having the potential to emit a total of one hundred tons or more of VOC per calendar year.
- (4) Paragraph (DDD) of this rule shall apply to all sources, regardless of date of construction or modification, that are located in Ashtabula, Butler, Clark, Clermont, Cuyahoga, Geauga, Greene, Hamilton, Lake, Lorain, Medina, Miami, Montgomery, Portage, Summit, or Warren county.
- (5) Paragraph (O)(2)(e) of this rule shall apply to any facility that has sources regardless of date of construction or modification that are located in Ashtabula, Butler, Clark, Clermont, Cuyahoga, Geauga, Greene, Hamilton, Lake, Lorain, Medina, Miami, Montgomery, Portage, Summit, or Warren county.
- (6) Paragraph (U) of this rule shall apply to all sources that meet ~~either~~any of the following:
- (a) That are located in ~~Butler, Clark, Clermont,~~ Delaware, Franklin, Greene, ~~Hamilton,~~ Licking, Lucas, Mahoning, Miami, Montgomery, Stark, Trumbull, ~~Warren~~ and Wood counties, regardless of date of construction or modification.
- (b) Are not in Ashtabula, Butler, Clermont, Cuyahoga, Geauga, Hamilton, Lake, Lorain, Medina, Portage, Summit, Warren or any of the counties listed in paragraph (A)(6)(a) of this rule, and the sources meet either of the following:
- (i) For which the construction or modification commenced on or after March 27, 1981.
- (ii) Which are located at a facility having the potential to emit a total of one hundred tons or more of VOC per calendar year.
- (c) For any source located in Butler, Clermont, Hamilton, or Warren counties subject to paragraph (U) of this rule prior to the effective date of this rule regardless of the date of construction or modification, the requirement to comply with paragraph (U) of this rule continues until the source becomes subject to and complies with rule 3745-21-26 of the Administrative Code.
- (7) Paragraph (C) of this rule applies to all sources that meet any of the following:
- (a) That are located in Clark, Delaware, Franklin, Greene, Licking, Lucas, Mahoning, Miami, Montgomery, Stark, Trumbull, and Wood counties, regardless of date of construction or modification.

(b) Are not in Ashtabula, Butler, Clermont, Cuyahoga, Geauga, Hamilton, Lake, Lorain, Medina, Portage, Summit, Warren or any of the counties listed in paragraph (A)(6)(a) of this rule, and the sources meet either of the following:

(i) For which the construction or modification commenced on or after October 19, 1979.

(ii) Which are located at a facility having the potential to emit a total of one hundred tons or more of VOC per calendar year.

(c) For any source located in Butler, Clermont, Hamilton or Warren counties subject to paragraph (C) of this rule prior to the effective date of this rule regardless of the date of construction or modification, the requirement to comply with paragraph (C) of this rule continues until the source becomes subject to and complies with rule 3745-21-29 of the Administrative Code.

~~(7)~~(8) Additional requirements or requirements which are more stringent than those specified in this rule may be applicable to new sources pursuant to rule 3745-31-05 of the Administrative Code.

(B) General provisions.

(1) Except as otherwise provided by this rule, compliance with the limitations specified in paragraphs (C) to (K), (S), (U), (Y), (FF), (OO) and (PP) of this rule is based upon a weighted average by volume of all coating materials employed in the coating line or printing line in any one day. The VOC contents and densities of the coating materials subject to paragraphs (C) to (K), (S), (U), (Y), (FF), (OO) and (PP) of this rule shall be determined in accordance with paragraph (B) of rule 3745-21-10 of the Administrative Code. The VOC emission rate, capture efficiency and control efficiency for coating lines or printing lines subject to paragraphs (C) to (K), (S), (U), (Y), (FF), (NN) and (PP) of this rule shall be determined in accordance with paragraph (C) of rule 3745-21-10 of the Administrative Code. The averaging of VOC emissions over two or more coating lines or printing lines in order to demonstrate compliance with an applicable emission limitation (i.e., cross-line averaging) is prohibited except as otherwise provided in this rule.

(2) Any approval granted by the director in accordance with paragraphs (I)(2), (K)(3), (L)(1)(a)(ii), (O)(2)(c)(iii), (O)(3)(c)(v), (O)(4)(a)(iii), (T)(4), (W)(1)(a)(ii), (W)(1)(c)(ii), (Z)(1)(a)(vii), (Z)(1)(b)(ii)(e), (Z)(1)(b)(iii)(c), (DD)(3)(e), (DD)(16), and (DD)(17)(b)(iii) of this rule shall be approved by the USEPA as a revision of the state implementation plan.

(3) Recordkeeping and reporting for coating lines and printing lines.

- (a) Except as otherwise provided by this rule, the owner or operator of a coating line or printing line subject to paragraphs (C) to (K), (S), (U), (Y), (FF) or (NN) to (PP) of this rule, or subject to rule 3745-21-26 of the Administrative Code shall demonstrate the ongoing status of compliance with the applicable emissions limitations or control requirements by means of one of the recordkeeping and reporting requirement alternatives specified in paragraph (B)(3) of this rule.
- (b) Any owner or operator of a coating line which is exempt from the emission limitations specified in paragraph (I) or (U) of this rule because the combined VOC emissions from all such coating lines at the facility are less than fifteen pounds of VOC per day (before add-on controls) shall collect and record the information each day and maintain the information at the facility for a period of three years:
- (i) The name and identification number of each coating, as applied.
 - (ii) The mass of VOC per volume (including water and exempt solvents) and the volume of each coating (including water and exempt solvents), as applied, used each day.
 - (iii) The total VOC emissions at the facility, as calculated using the following equation:

$$T = \sum_{i=1}^n A_i B$$

where:

T = Total VOC emissions from the combined coating lines before the application of capture systems and control devices, in units of pounds per day.

n = Number of different coatings applied in the coating lines at the facility.

i = Subscript denoting an individual coating.

A_i = Mass of VOC per volume of coating (i) (including water and exempt solvents), as applied, used at the facility, in units of pounds VOC per gallon.

B_i = Volume of coating (i) (including water and exempt solvents), as applied, used at the facility, in units of gallons per day. The instrument or method by which the owner or operator accurately measured or calculated the volume of each coating, as applied, shall also be described in the certification to the director.

- (c) Any owner or operator of a coating line referenced in paragraph (B)(3)(b) of this rule shall notify the director within forty-five days after the exceedance occurs, of any daily record showing that the combined VOC emissions from all such coating lines at the facility are equal to or greater than fifteen pounds of VOC per day (before add-on controls). ~~A copy of such record shall be sent to the director within forty-five days after the exceedance occurs.~~
- (d) Any owner or operator of a coating line which is exempt from the emission limitations specified in paragraph (U)(1) of this rule, pursuant to paragraph (U)(2)(e) of this rule, shall collect and record the following information each day for each such coating line and maintain the information at the facility for a period of three years:
- (i) The name and identification number of each coating employed in the coating line.
 - (ii) The volume, in gallons, of each coating employed in the coating line.
 - (iii) The total volume, in gallons, of all of the coatings employed in the coating line.
- (e) Any owner or operator of a coating line referenced in paragraph (B)(3)(d) of this rule shall notify the director within forty-five days of the exceedance occurring of any daily record showing that the coating line employs more than the applicable maximum daily coating usage limit. ~~A copy of such record shall be sent to the director within forty-five days after the exceedance occurs.~~
- (f) Any owner or operator of a coating line or printing line who elects to demonstrate the ongoing status of compliance with the applicable emission limitation by means of the use of complying coatings (i.e., each coating complies with the applicable emission limitation as applied) shall

collect and record the following information each month and maintain the information at the facility for a period of three years:

- (i) The name and identification number of each coating, as applied.
- (ii) The mass of VOC per volume of each coating (excluding water and exempt solvents), as applied.

This information does not have to be kept on a line-by-line basis. Also, if an owner or operator mixes complying coatings at a coating line, it is not necessary to record the VOC content of the resulting mixture.

- (g) Any owner or operator of a coating line or printing line referenced in paragraph (B)(3)(f) of this rule shall notify the director within thirty days of the end of the calendar month of any monthly record showing the use of noncomplying coatings. ~~A copy of such record shall be sent to the director within thirty days following the end of the calendar month.~~
- (h) Any owner or operator of a coating line or printing line who elects to demonstrate the ongoing status of compliance with the applicable emission limitation by means of a daily volume-weighted average VOC content shall collect and record the following information each day for the coating line or printing line and maintain the information at the facility for a period of three years:
 - (i) The name and identification number of each coating, as applied.
 - (ii) The mass of VOC per volume (excluding water and exempt solvents) and the volume of each coating (excluding water and exempt solvents), as applied.
 - (iii) The daily volume-weighted average VOC content of all coatings, as applied, calculated in accordance with the equation specified in paragraph (B)(9) of rule 3745-21-10 of the Administrative Code for $C_{\text{voc},2}$.
- (i) Any owner or operator of a coating line or printing line referenced in paragraph (B)(3)(h) of this rule shall notify the director within forty-five days after the exceedance occurs of any daily record showing that the daily volume-weighted average VOC content exceeds the applicable emission limitation. ~~A copy of such record shall be sent to the director within forty-five days after the exceedance occurs.~~

- (j) Any owner or operator of a coating line who elects to demonstrate the ongoing status of compliance with the applicable pounds of VOC per gallon of solids limitation by means of control equipment shall collect and record the following information each day for the coating line and maintain the information at the facility for a period of three years:
- (i) The name and identification number of each coating used.
 - (ii) The mass of VOC per unit volume of coating solids, as applied, the volume solids content, as applied, and the volume, as applied, of each coating.
 - (iii) The maximum VOC content (mass of VOC per unit volume of coating solids, as applied) or the daily volume-weighted average VOC content (mass of VOC per unit volume of coating solids, as applied) of all the coatings.
 - (iv) The calculated, controlled VOC emission rate, in mass of VOC per unit volume of coating solids, as applied. The controlled VOC emission rate shall be calculated using the following:
 - (a) Either the maximum VOC content or the daily volume-weighted VOC content recorded in accordance with paragraph (B)(3)(j)(iii) of this rule.
 - (b) The overall control efficiency for the control equipment as determined during the most recent emission test that demonstrated that the source was in compliance.
 - (v) A log or record of operating time for the capture (collection) system, control device, monitoring equipment, and the associated coating line.
 - (vi) For thermal incinerators, all three-hour periods of operation during which the average combustion temperature was more than fifty degrees Fahrenheit below the average combustion temperature during the most recent performance test that demonstrated that the source was in compliance.
 - (vii) For catalytic incinerators, all three-hour periods of operation during which the average temperature of the process vent stream immediately before the catalyst bed is more than fifty degrees Fahrenheit below the average temperature of the process vent

stream during the most recent performance test that demonstrated that the source was in compliance, and one of the following:

- (a) All three-hour periods of operation during which the average temperature difference across the catalyst bed is less than eighty per cent of the average temperature differences during the most recent performance test that demonstrated that the source was in compliance.
 - (b) Records required by an inspection and maintenance plan for the catalytic incinerator that meets paragraph (S) of rule 3745-21-10 of the Administrative Code.
- (viii) For carbon adsorbers, all three-hour periods of operation during which the average VOC concentration or reading of organics in the exhaust gases is more than twenty per cent greater than the average exhaust gas concentration or reading measured by the organics monitoring device during the most recent determination of the recovery efficiency of the carbon adsorber that demonstrated that the source was in compliance.
- (k) Any owner or operator of a coating line referenced in paragraph (B) (3)(j) of this rule shall notify the director within forty-five days after the exceedance occurs of any daily record showing that the calculated, controlled VOC emission rate exceeds the applicable pounds of VOC per gallon of solids limitation. ~~A copy of such record shall be sent to the director within forty-five days after the exceedance occurs.~~
- (l) Any owner or operator of a coating line or printing line who elects to demonstrate the ongoing status of compliance with the applicable capture and control efficiency requirements or overall control efficiency requirements contained in paragraph (B)(6), (H), (Y), (NN), (PP), or (XX) of this rule shall collect and record the following information each day for the control equipment and maintain the information at the facility for a period of three years:
- (i) A log of operating time for the capture (collection) system, control device, monitoring equipment, and the associated coating line or printing line.
 - (ii) For thermal incinerators, all three-hour periods of operation during which the average combustion temperature was more than fifty degrees Fahrenheit below the average combustion temperature

during the most recent performance test that demonstrated that the source was in compliance.

- (iii) For catalytic incinerators, all three-hour periods of operation during which the average temperature of the process vent stream immediately before the catalyst bed is more than fifty degrees Fahrenheit below the average temperature of the process vent stream during the most recent performance test that demonstrated that the source was in compliance, and one of the following:
 - (a) All three-hour periods of operation during which the average temperature difference across the catalyst bed is less than eighty per cent of the average temperature differences during the most recent performance test that demonstrated that the source was in compliance.
 - (b) Records required by an inspection and maintenance plan for the catalytic incinerator that meets paragraph (S) of rule 3745-21-10 of the Administrative Code.
- (iv) For carbon adsorbers, all three-hour periods of operation during which the average VOC concentration or reading of organics in the exhaust gases is more than twenty per cent greater than the average exhaust gas concentration or reading measured by the organics monitoring device during the most recent determination of the recovery efficiency of the carbon adsorber that demonstrated that the source was in compliance.
- (m) Any owner or operator of a coating line or printing line referenced in paragraphs (B)(3)(j) and (B)(3)(l) of this rule shall submit to the director by April thirtieth, July thirty-first, October thirty-first, and January thirty-first, that cover the records for the previous calendar quarter, quarterly summaries of the records required by paragraphs (B)(3)(j)(v) to (B)(3)(j)(viii) and (B)(3)(l) of this rule. ~~These quarterly reports shall be submitted by April thirtieth, July thirty-first, October thirty-first, and January thirty-first, and shall cover the records for the previous calendar quarters.~~
- (n) Any owner or operator of a coating line or printing line referenced in paragraphs (B)(3)(j) and (B)(3)(l) of this rule shall install and operate continuous monitoring and recording devices (i.e., for temperature or VOC concentration) and, if necessary, perform emission tests for the coating line or printing line to enable the recordkeeping required by paragraphs (B)(3)(j)(vi) to (B)(3)(j)(viii) and (B)(3)(l)(ii) to (B)(3)(l)

(iv) of this rule. The continuous monitoring and recording devices shall be installed and placed in operation either within one hundred eighty days of March 31, 1993 or by the date of operation of any new control equipment installed for the coating line or printing line after March 31, 1993 to achieve compliance with the VOC control requirements of this rule. The continuous monitoring and recording devices shall be capable of accurately measuring the desired parameter. The owner or operator shall properly operate and maintain the devices in accordance with the manufacturer's recommendations.

(4) Recordkeeping and reporting for sources other than coating lines and printing lines.

(a) Except as otherwise provided by this rule, the owner or operator of a source other than a coating line or printing line that is subject to paragraphs (O), (W), (X), (CC), (EE), (KK) to (MM), (SS) to (VV), or (YY) to (BBB) of this rule shall demonstrate the ongoing status of compliance with the applicable emissions limitations or control requirements by means of one of the recordkeeping and reporting requirement alternatives specified in paragraph (B)(4) of this rule.

(b) Any owner or operator of a source referenced in paragraph (B)(4)(a) of this rule who elects to demonstrate the ongoing status of compliance with the applicable emission limitation or control requirement by means of control equipment shall collect and record the following information each day for the source and maintain the information at the facility for a period of three years:

(i) A log or record of operating time for the capture (collection) system, control device, monitoring equipment, and the associated source.

(ii) For thermal incinerators, all three-hour periods of operation during which the average combustion temperature was more than fifty degrees Fahrenheit below the average combustion temperature during the most recent performance test that demonstrated that the source was in compliance.

(iii) For catalytic incinerators, all three-hour periods of operation during which the average temperature of the process vent stream immediately before the catalyst bed is more than fifty degrees Fahrenheit below the average temperature of the process vent stream during the most recent performance test that demonstrated that the source was in compliance, and one of the following:

- (a) All three-hour periods of operation during which the average temperature difference across the catalyst bed is less than eighty per cent of the average temperature differences during the most recent performance test that demonstrated that the source was in compliance.
 - (b) Records required by an inspection and maintenance plan for the catalytic incinerator that meets paragraph (S) of rule 3745-21-10 of the Administrative Code.
- (iv) Where an absorber is the final control device and an organic monitoring device is used, all three-hour periods of operation during which the average concentration level or reading of organic compounds in the exhaust gases is more than twenty per cent greater than the exhaust gas organic compound concentration level or reading measured by the most recent performance test that demonstrated that the source was in compliance.
- (v) Where an absorber is the final control device and an organic monitoring device is not used, either of the following:
 - (a) All three-hour periods of operation during which the average absorbing liquid temperature was more than twenty degrees Fahrenheit above the average absorbing liquid temperature during the most recent performance test that demonstrated that the source was in compliance.
 - (b) All three-hour periods of operation during which the average absorbing liquid specific gravity was more than 0.1 unit above, or more than 0.1 unit below the average absorbing liquid specific gravity during the most recent performance test that demonstrated that the source was in compliance (unless monitoring of an alternative parameter, which is a measure of the degree of absorbing liquid saturation, is approved by the director, in which case the director will define appropriate parameter boundaries and periods of operation during which they are exceeded).
- (vi) Where a carbon adsorber is the final control device and an organic monitoring device is used, all three-hour periods of operation during which the average concentration level or reading of organic compounds in the exhaust gases is more than twenty per cent greater than the exhaust gas organic compound concentration level

or reading measured by the most recent performance test that demonstrated that the source was in compliance.

(vii) Where a carbon adsorber is the final control device and an organic monitoring device is not used, either of the following:

(a) All carbon bed regeneration cycles during which the total mass steam flow rate was more than ten per cent below the total mass steam flow during the most recent performance test that demonstrated that the source was in compliance.

(b) All carbon bed regeneration cycles during which the temperature of the carbon bed after regeneration (and after completion of any cooling cycle) was more than ten per cent greater than the carbon bed temperature (in degrees Celsius) during the most recent performance test that demonstrated that the source was in compliance.

(viii) Where a condenser is the final control device and an organic monitoring device is used, all three-hour periods of operation during which the average concentration level or reading of organic compounds in the exhaust gases is more than twenty per cent greater than the exhaust gas organic compound concentration level or reading measured by the most recent performance test that demonstrated that the source was in compliance.

(ix) When a condenser is the final control device and an organic monitoring device is not used, all three-hour periods of operation during which the average exit (product side) condenser operating temperature was more than eleven degrees Fahrenheit above the average exit (product side) operating temperature during the most recent performance test that demonstrated that the source was in compliance.

(x) For flares, all periods during which the electric arc ignition system or pilot flame is not functioning properly.

(c) Any owner or operator of a source referenced in paragraph (B)(4)(a) of this rule shall submit to the director by April thirtieth, July thirty-first, October thirty-first, and January thirty-first, that cover the records for the previous calendar quarters, quarterly summaries of the records required by paragraph (B)(4)(b) of this rule. ~~These quarterly reports shall be submitted by April thirtieth, July thirty-first, October thirty-first, and~~

~~January thirty-first, and shall cover the records for the previous calendar quarters.~~

- (d) Any owner or operator of a source referenced in paragraph (B)(4)(a) of this rule shall either within one hundred eighty days of March 31, 1993 or by the date of operation of any new control equipment installed for the source after March 31, 1993 install and operate continuous monitoring and recording devices (i.e., for temperature, VOC concentration, arcing of an electric arc ignition system, or presence of a pilot flame) and, if necessary, perform emission tests for the source to enable the recordkeeping required by paragraph (B)(4)(b) of this rule. ~~The continuous monitoring and recording devices shall be installed and placed in operation either within one hundred eighty days of March 31, 1993 or by the date of operation of any new control equipment installed for the source after March 31, 1993 to achieve compliance with the VOC control requirements of this rule.~~ The continuous monitoring and recording devices shall be capable of accurately measuring the desired parameter, and the owner or operator shall properly operate and maintain the devices in accordance with the manufacturer's recommendations.
- (5) Any owner or operator of a coating line, printing line, or other source that is subject to the recordkeeping and reporting requirements contained in paragraph (B)(3) or (B)(4) of this rule may propose to the director an alternative recordkeeping and reporting program. If the alternative recordkeeping and reporting program is approved by the director and USEPA as a revision to the state implementation plan, the alternative recordkeeping and reporting program shall supersede paragraph (B)(3) or (B)(4) of this rule and ~~shall~~ be specified in the terms and conditions of the permit, variance, or order issued by the director for the coating line, printing line, or other source. ~~Any alternative recordkeeping and reporting program approved by the director shall also be approved by the USEPA as a revision to the state implementation plan.~~
- (6) In lieu of complying with the pounds of VOC per gallon of solids limitations contained in paragraphs (D), (E), (F)(1), (G), (I)(1), (J), (K)(1), and (U) of this rule, any owner or operator of a coating line that employs a control system may choose to demonstrate that the capture and control equipment provide not less than an eighty one per cent reduction, by weight, in the overall VOC emissions from the coating line and that the control equipment has an efficiency of not less than ninety per cent, by weight, for the VOC emissions vented to the control equipment. In such cases, the owner or operator shall comply with the certification and permit application requirements specified in paragraph (B)(3) of rule 3745-21-04 of the Administrative Code and shall achieve compliance with the overall VOC emission reduction and control efficiency requirements

in accordance with the applicable compliance schedules contained in paragraph (C) of rule 3745-21-04 of the Administrative Code. Also, in such cases, the owner or operator of the coating line shall be subject to the recordkeeping and reporting requirements contained in paragraph (B)(3)(l) of this rule.

- (7) In lieu of complying with the pounds of VOC per gallon of solids limitations contained in paragraphs (I)(4) and (K)(6) of this rule, any owner or operator of a coating line that employs a control system may choose to demonstrate that the capture and control equipment provide not less than a ninety per cent reduction, by weight, in the overall VOC emissions from the coating line and that the control equipment has an efficiency of not less than ninety per cent, by weight, for the VOC emissions vented to the control equipment. In such cases, the owner or operator shall comply with the certification and permit application requirements specified in paragraph (B)(3)(b) of rule 3745-21-04 of the Administrative Code and shall achieve compliance with the overall VOC emission reduction and control efficiency requirements in accordance with the applicable compliance schedules contained in paragraph (C) of rule 3745-21-04 of the Administrative Code. Also, in such cases, the owner or operator of the coating line shall be subject to the recordkeeping and reporting requirements contained in paragraph (B)(3)(l) of this rule.

(C) Surface coating of automobiles and light-duty trucks.

~~For any source located in Ashtabula, Cuyahoga, Geauga, Lake, Lorain, Medina, Portage, or Summit county subject to paragraph (C) of this rule, the requirement to comply with paragraph (C) of this rule shall terminate at such time the source becomes subject to and complies with rule 3745-21-29 of the Administrative Code.~~

- (1) Except as otherwise provided in paragraphs (C)(2), (C)(3) and (C)(6) of this rule, no owner or operator of an automobile or light-duty truck assembly plant ~~may~~ shall cause, allow or permit the discharge into the ambient air of any VOC after the dates specified in rule 3745-21-04 of the Administrative Code in excess of the following:
- (a) For a prime coat coating line employing electrodeposition, one of the following:
- (i) 1.2 pounds of VOC per gallon of coating, excluding water and exempt solvents, or, if a control system is employed, 1.4 pounds of VOC per gallon of solids from the electrodeposition coating line.

- (ii) 1.4 pounds of VOC per gallon of solids from any electrodeposition (EDP) coating line when the solids turnover ratio (R_T) is 0.16 or greater. R_T shall be calculated as follows:

$$R_T = T_E / L_E$$

where:

T_E = total volume of coating solids that is added to the EDP coating line in a calendar month (gallons).

L_E = volume design capacity of the EDP system, which is the total liquid volume contained in the EDP system's tanks, pumps, recirculating lines, filters, etc. at the system's designed liquid operating level (gallons).

- (iii) 1.4 # $350^{(0.160-R_T)}$ pounds of VOC per gallon of solids from any EDP coating line when R_T , calculated according to the equation in paragraph (C)(1)(a)(ii) of this rule, is greater than or equal to 0.040 and less than 0.160.
- (iv) When R_T , calculated according to the equation in paragraph (C)(1)(a)(ii) of this rule, is less than 0.040 for any EDP coating line, there is no emission limit.
- (v) 2.8 pounds of VOC per gallon of coating, excluding water and exempt solvents, or 15.1 pounds VOC per gallon of deposited solids from the guidecoat or surfacer coating line. (Antichip coatings applied to automobile and light-duty truck components such as rocker panels, the bottom edges of doors and fenders, and the leading edge of the roof, are considered to be guidecoat or surfacer coatings.)
- (b) For a prime coat coating line not employing electrodeposition, 1.9 pounds of VOC per gallon of coating, excluding water and exempt solvents, or, if a control system is employed, 2.6 pounds of VOC per gallon of solids.
- (c) For a topcoat coating line, 2.8 pounds of VOC per gallon of coating, excluding water and exempt solvents, or 15.1 pounds VOC per gallon of deposited solids.
- (d) For a final repair coating line, 4.8 pounds of VOC per gallon of coating, excluding water and exempt solvents, or, if a control system is employed, 13.8 pounds of VOC per gallon of solids.

- (2) The emission limitations specified in paragraph (C)(1) of this rule shall apply to the application of surface coatings, except sound-proofing materials, to the frame, main body, interior panels and exterior sheet metal such as the hood, trunk lid, fenders, cargo boxes, doors and grill openings of an automobile or light-duty truck and to other parts that are coated along with these bodies or body parts. The emission limitation specified in paragraph (C)(1)(c) of this rule is a daily volume-weighted average of the entire topcoat operation (i.e., all spray booths, flash-off areas and bake ovens where topcoat coatings are applied, dried, and cured, except those spray booths, flash-off areas and bake ovens in the final repair coating line). The emission limitation specified in paragraph (C)(1)(a)(v) of this rule is a daily volume-weighted average of the entire guidecoat and surfacer operation (i.e., all spray booths, flash-off areas and bake ovens where guidecoat and surfacer coatings are applied, dried, and cured, except those spray booths, flash-off areas and bake ovens in the final repair topcoat coating line).
- (3) When an owner or operator of an automobile or light-duty truck assembly plant chooses to comply with the pounds VOC per gallon of deposited solids limitation specified in paragraphs (C)(1)(a)(v) and (C)(1)(c) of this rule, the test method for determining the transfer efficiency of the coating line and for determining compliance of the coating line with applicable emission limitations shall be in accordance with the publication specified in paragraph (C)(4) of this rule.
- (4) As expeditiously as practicable but not later than December 1, 1990 for any topcoat coating line and not later than July 1, 1995 for any guidecoat or surfacer coating line, any owner or operator of an automobile or light-duty truck assembly plant shall maintain daily records for the guidecoat or surfacer coating line and for the topcoat coating line and shall demonstrate compliance with paragraphs (C)(1)(a)(v) and (C)(1)(c) of this rule in accordance with the USEPA publication entitled "Protocol for Determining the Daily Volatile Organic Compound Emission Rate of Automobile and Light-Duty Truck Topcoat Operations". A copy of records indicating an exceedance of paragraphs (C)(1)(a)(v) and (C)(1)(c) of this rule limitations shall be sent to the director within thirty days following the end of the calendar month. These recordkeeping and reporting requirements are in lieu of those contained in paragraph (B)(3) of this rule.
- (5) Compliance with the limitation specified in paragraph (C)(1)(d) of this rule is based upon a weighted average by volume of all coating materials employed in the final repair coating line in any one month. Any owner or operator of a final repair coating line who elects to demonstrate the ongoing status of compliance

by means of a monthly volume-weighted average VOC content shall meet the following recordkeeping and reporting requirements:

(a) Recordkeeping.

The owner or operator shall collect and record the following information each month for the final repair coating line and maintain the information at the facility for a period of three years:

- (i) The name and identification number of each coating, as applied.
- (ii) The mass of VOC per volume (excluding water and exempt solvents) and the volume of each coating (excluding water and exempt solvents), as applied.
- (iii) The monthly volume-weighted average VOC content of all coatings, as applied, calculated in accordance with the equation specified in paragraph (B)(9) of rule 3745-21-10 of the Administrative Code for $(C_{VOC,2})_A$.

(b) Reporting.

The owner or operator shall notify the director and submit a copy of such notification within thirty days following the end of the calendar month of any monthly record showing that the monthly volume-weighted average VOC content exceeds the applicable emission limitation. ~~A copy of such monthly record shall be sent to the director within thirty days following the end of the calendar month.~~

- (6) An owner or operator of an automobile or light-duty truck assembly plant may choose to comply with the following in lieu of paragraphs (C)(1)(a) to (C)(1)(d) of this rule if the maximum number of motor vehicles assembled is less than thirty-five per day:

No owner or operator of an automobile or light-duty truck assembly plant may cause, allow, or permit the discharge into the ambient air of any VOC in excess of the following:

- (a) 5.0 pounds of VOC per gallon of coating, excluding water and exempt solvents, for guidecoats, automotive primer-sealers and automotive primer-surfacers, or, if a control system is employed, 15.6 pounds of VOC per gallon of solids, as applied.

(b) 5.4 pounds of VOC per gallon of coating, excluding water and exempt solvents, for automotive topcoats or, if a control system is employed, 20.3 pounds VOC per gallon of solids, as applied.

(7) An owner or operator of the applicable coating line who elects to demonstrate the ongoing status of compliance with paragraph (C)(6) by means of a monthly volume-weighted average VOC content shall meet the following:

(a) Recordkeeping.

The owner or operator shall collect and record the following information each month for the coating line and maintain the information at the facility for a period of three years:

(i) The name and identification number of each coating, as applied.

(ii) The mass of VOC per volume (excluding water and exempt solvents) and the volume of each coating (excluding water and exempt solvents), as applied.

(iii) The monthly volume-weighted average VOC content of all coatings, as applied, calculated in accordance with the equation specified in paragraph (B)(9) of rule 3745-21-10 of the Administrative Code for $(C_{voc,2})_A$.

(b) Reporting.

The owner or operator shall notify the director and submit a copy of each notification within thirty days of the end of the calendar month of any monthly record showing that the monthly volume-weighted average VOC content exceeds the applicable emission limitation. ~~A copy of such monthly record shall be sent to the director within thirty days following the end of the calendar month.~~

(8) Any owner or operator of a coating line who elects to demonstrate the ongoing status of compliance with the applicable pounds of VOC per gallon of solids limitation as specified in paragraph (C)(1)(d), (C)(6)(a), or (C)(6)(b) of this rule by means of control equipment shall collect and record the following information each month for the coating line and maintain the information at the facility for a period of three years:

(a) The name and identification number of each coating used.

- (b) The mass of VOC per unit volume of coating solids, as applied, the volume solids content, as applied, and the volume, as applied, of each coating.
- (c) The maximum VOC content (mass of VOC per unit volume of coating solids, as applied) or the monthly volume-weighted average VOC content (mass of VOC per unit volume of coating solids, as applied) of all the coatings.
- (d) The calculated, controlled VOC emission rate, in mass of VOC per unit volume of coating solids, as applied. ~~The controlled VOC emission rate shall be,~~ calculated using the following:
 - (i) Either the maximum VOC content or the monthly volume-weighted VOC content recorded in accordance with paragraph (B)(3)(j)(iii) of this rule.
 - (ii) The overall control efficiency for the control equipment as determined during the most recent emission test that demonstrated that the source was in compliance.
- (e) A log or record of operating time for the capture (collection) system, control device, monitoring equipment, and the associated coating line.
- (f) For thermal incinerators, all three-hour periods of operation during which the average combustion temperature was more than fifty degrees Fahrenheit below the average combustion temperature during the most recent performance test that demonstrated that the source was in compliance.
- (g) For catalytic incinerators, all three-hour periods of operation during which the average temperature of the process vent stream immediately before the catalyst bed is more than fifty degrees Fahrenheit below the average temperature of the process vent stream during the most recent performance test that demonstrated that the source was in compliance, and one of the following:
 - (i) All three-hour periods of operation during which the average temperature difference across the catalyst bed is less than eighty per cent of the average temperature differences during the most recent performance test that demonstrated that the source was in compliance.
 - (ii) Records required by an inspection and maintenance plan for the catalytic incinerator that meets paragraph (S) of rule 3745-21-10 of the Administrative Code.

- (h) For carbon adsorbers, all three-hour periods of operation during which the average VOC concentration or reading of organics in the exhaust gases is more than twenty per cent greater than the average exhaust gas concentration or reading measured by the organics monitoring device during the most recent determination of the recovery efficiency of the carbon adsorber that demonstrated that the source was in compliance.
- (9) Any owner or operator of a coating line referenced in paragraph ~~(C)(7)~~(C)(8) of this rule shall notify the director and submit a copy of such notification within thirty days following the end of the calendar month of any monthly record showing that the calculated, controlled VOC emission rate exceeds the applicable pounds of VOC per gallon of solids limitation. A copy of such monthly record shall be sent to the director within thirty days following the end of the calendar month.
- (10) The following coatings are excluded from the emission limitations specified in paragraphs (C)(1) and (C)(6) of this rule:
 - (a) Aerosol coatings.
 - (b) Coatings supplied in containers with a net volume of sixteen ounces or less, or a net weight of one pound or less.
- (D) Surface coating of cans.
 - (1) Except as otherwise provided in paragraph (B)(6) of this rule, no owner or operator of a two-piece can coating operation may cause, allow, or permit the discharge into the ambient air of any volatile organic compounds after the date specified in paragraph (C)(3) of rule 3745-21-04 of the Administrative Code in excess of the following:
 - (a) 2.8 pounds of VOC per gallon of coating, excluding water and exempt solvents, or, if a control system is employed, 4.5 pounds of VOC per gallon of solids from a basecoat coating line.
 - (b) 2.8 pounds of VOC per gallon of coating, excluding water and exempt solvents, or, if a control system is employed, 4.5 pounds of VOC per gallon of solids from an overvarnish coating line.
 - (c) 4.2 pounds of VOC per gallon of coating, excluding water and exempt solvents, or, if a control system is employed, 9.8 pounds of VOC per gallon of solids from an interior body coating line.

- (d) 4.2 pounds of VOC per gallon of coating, excluding water and exempt solvents, or, if a control system is employed, 9.8 pounds of VOC per gallon of solids from an exterior bottom end coating line.
 - (e) 3.7 pounds of VOC per gallon of coating, excluding water and exempt solvents, or, if a control system is employed, 7.4 pounds of VOC per gallon of solids from an end sealing compound coating line.
- (2) Except as otherwise provided in paragraph (B)(6) of this rule, no owner or operator of a three-piece can coating operation may cause, allow, or permit the discharge into the ambient air of any volatile organic compounds after the date specified in paragraph (C)(3) of rule 3745-21-04 of the Administrative Code in excess of the following:
- (a) 2.8 pounds of VOC per gallon of coating, excluding water and exempt solvents, or, if a control system is employed, 4.5 pounds of VOC per gallon of solids from a basecoat coating line.
 - (b) 2.8 pounds of VOC per gallon of coating, excluding water and exempt solvents, or, if a control system is employed, 4.5 pounds of VOC per gallon of solids from an overvarnish coating line.
 - (c) 4.2 pounds of VOC per gallon of coating, excluding water and exempt solvents, or, if a control system is employed, 9.8 pounds of VOC per gallon of solids from an interior body coating line.
 - (d) 5.5 pounds of VOC per gallon of coating, excluding water and exempt solvents, or, if a control system is employed, 21.7 pounds of VOC per gallon of solids from a side-seam coating line.
 - (e) 3.7 pounds of VOC per gallon of coating, excluding water and exempt solvents, or, if a control system is employed, 7.4 pounds of VOC per gallon of solids from an end sealing compound coating line.
- (3) Alternative daily emission limitation:
- (a) Any owner or operator of a two-piece or three-piece can coating operation may obtain from the director an alternative daily emission limitation for the emission limitations specified in paragraph (D)(1) or (D)(2) of this rule. The alternative daily emission limitation shall be determined according to paragraph (D)(3)(b) of this rule and the actual daily emission shall be determined according to paragraph (D)(3)(c) of this rule. Prior to obtaining the alternative daily emission limitation, the owner or operator shall demonstrate to the satisfaction of the director that the

actual daily emission will not exceed the alternative daily emission limitation after the date specified in paragraph (C)(3) of rule 3745-21-04 of the Administrative Code and that the record-keeping requirements of paragraph (D)(3)(d) of this rule shall be met.

- (b) The alternative daily emission limitation (A_d) shall be determined on a daily basis as follows:

$$A_d = \sum_{i=1}^n V_i L_i \frac{(D_i - C_i)}{(D_i - L_i)}$$

Where A_d = pounds of VOC emissions allowed for the day.

C = VOC content of surface coating employed, in pounds of VOC per gallon of coating, excluding water and exempt solvents.

D = density of VOC content of surface coating employed, in pounds of VOC per gallon of VOC (a standard density of 7.36 may be used if it is used for all surface coatings employed).

V = volume of surface coating employed for the day, in gallons (excluding water and exempt solvents).

L = emission limitation for the surface coating employed as specified in paragraph (D)(1) or (D)(2) of this rule, in pounds of VOC per gallon of coating (excluding water and exempt solvents).

i = subscript denoting a specific surface coating employed.

n = total number of surface coatings employed in can coating operation.

- (c) The actual daily emission (E_d) shall be determined on a daily basis as follows:

$$E_d = \sum_{i=1}^n V_i C_i (1 - F_i)$$

Where E_d = actual pounds of VOC emissions for the day.

F = fraction by weight of VOC emissions from the surface coating reduced or prevented from being emitted by control equipment, and V, C, i and n are defined as in paragraph (D)(3)(b) of this rule.

(d) Record-keeping:

(i) Daily records shall be maintained for a period of not less than two years which list the usage of surface coatings or which list other data, as authorized by the director, that approximate the usage of surface coatings. The following data shall be listed for each surface coating being recorded: VOC content (in pounds of VOC per gallon of coating, excluding water and exempt solvents), density of VOC content of coating (in pounds of VOC per gallon of VOC) unless the standard density of 7.36 is recorded, and the type of surface coating according to the classification contained within paragraphs (D)(1) and (D)(2) of this rule.

(ii) Daily records shall be maintained for a period of not less than two years which include the following for any control equipment designed to reduce or prevent the emission of VOC: downtime, any operational problems or malfunctions which reduce the effective control efficiency, and the average control efficiency, if less than the normally expected control efficiency.

(iii) Other records shall be maintained, as deemed necessary by the director, in order to provide information on VOC emissions or compliance with the alternative daily emission limitation.

(E) Except as otherwise provided in paragraphs (B)(6) and (D) of this rule, no owner or operator of a coil coating line may cause, allow or permit the discharge into the ambient air of any VOCs after the date specified in paragraph (C)(4) of rule 3745-21-04 of the Administrative Code in excess of 2.6 pounds of VOC per gallon of coating, excluding water and exempt solvents, or, if a control system is employed, 4.0 pounds of VOC per gallon of solids from a prime coat, topcoat, or single coat coating line.

(F) Paper coating lines.

(1) Except as otherwise provided in paragraph (B)(6) of this rule, no owner or operator of a paper coating line which has a maximum application of coating materials greater than three gallons in any one day may cause, allow or permit the

discharge into the ambient air of any volatile organic compounds after the date specified in paragraph (C)(5) of rule 3745-21-04 of the Administrative Code in excess of 2.9 pounds of VOC per gallon of coating, excluding water and exempt solvents, or, if a control system is employed, 4.8 pounds of VOC per gallon of solids from such paper coating line.

(2) In addition to paragraph (F)(1) of this rule, the following are applicable to all paper coating lines located in Ashtabula, Butler, Clermont, Cuyahoga, Geauga, Hamilton, Lake, Lorain, Medina, Portage, and Summit, and Warren counties:

(a) Any owner or operator of a paper coating line with potential emissions that are equal to or greater than 25.0 tons per year of VOC before the application of capture and control devices shall comply with either of the following for the coating line:

(i) Employ a control system in order to reduce VOC emissions from the paper coating line by at least ninety per cent or maintain a maximum VOC outlet concentration of twenty ppmv on a dry basis, whichever is less stringent.

(ii) Employ coatings in the paper coating line that comply with the following VOC content limitations:

VOC content limitations

Coating Type	Pound of VOC/Pound of Coating
paper, film and foil surface coatings (not including pressure sensitive tape and labels)	0.08
pressure sensitive tape and label surface coatings	0.067

(b) Work practice standards for cleaning materials.

Unless emissions to the atmosphere are controlled by an approved emission control system with an overall control efficiency of at least ninety per cent, any person using an organic solvent for cleanup shall do the following:

(i) Store all VOC containing cleaning materials and used shop towels in closed containers.

- (ii) Ensure that mixing and storage containers used for VOC-containing cleaning materials are kept closed at all times except when depositing or removing these materials.
 - (iii) Minimize spills of VOC-containing cleaning materials.
 - (iv) Convey VOC-containing cleaning materials from one location to another in closed containers or pipes.
 - (v) Minimize VOC emission from cleaning of storage, mixing, and conveying equipment.
- (G) Except as otherwise provided in paragraph (B)(6) of this rule, no owner or operator of a fabric coating line may cause, allow or permit the discharge into the ambient air of any VOCs after the date specified in paragraph (C)(6) of rule 3745-21-04 of the Administrative Code in excess of 2.9 pounds of VOC per gallon of coating, excluding water and exempt solvents, or, if a control system is employed, 4.8 pounds of VOC per gallon of solids from a fabric coating line.
- (H) No owner or operator of a vinyl coating line may cause, allow or permit the discharge into the ambient air of any VOCs from such coating line after the date specified in paragraph (C)(7) of rule 3745-21-04 of the Administrative Code, unless either paragraph (H)(1) or (H)(2) of this rule is satisfied.
- (1) The VOC content of the coatings employed in the vinyl coating line, as determined under paragraph (B) of rule 3745-21-10 of the Administrative Code, does not exceed either of the following limitations:
 - (a) 4.8 pounds of VOC per gallon of vinyl coating, excluding water and exempt solvents.
 - (b) Twenty-five per cent VOC by volume of the volatile matter of the vinyl coating.
 - (2) The vinyl coating line is equipped with a capture system and associated control system which are designed and operated to achieve the following efficiencies for VOCs, as determined under paragraph (C) of rule 3745-21-10 of the Administrative Code:
 - (a) A capture efficiency which is at least seventy-five per cent by weight.
 - (b) A control efficiency which is at least ninety per cent by weight.

- (3) ~~Paragraphs (H)(1) and (H)(2) of this rule shall not apply to the~~ The application of organisol or plastisol coatings are exempt from paragraphs (H)(1) and (H)(2) of this rule.

(I) Surface coating of metal furniture.

- (1) Except as otherwise provided in paragraphs (B)(6), (I)(2) and (I)(3) of this rule, no owner or operator of a prime coat, topcoat, or single coat coating line for metal furniture may cause, allow or permit the discharge into the ambient air of any VOCs after the date specified in paragraph (C)(8) of rule 3745-21-04 of the Administrative Code in excess of 3.0 pounds of VOC per gallon of coating, excluding water and exempt solvents, or, if a control system is employed, 5.1 pounds of VOC per gallon of solids from such prime coat, topcoat, or single coat coating line.
- (2) Any owner or operator of a prime coat, topcoat, or single coat coating line for metal furniture may obtain from the director an alternative emission limitation for the limitation specified in paragraph (I)(1) of this rule. The owner or operator shall demonstrate to the satisfaction of the director, prior to obtaining an alternative emission limitation, that the alternative emission limitation is, at a minimum, equivalent in terms of total daily emissions of VOCs to the applicable requirement of paragraph (I)(1) of this rule. For purposes of this demonstration, the director shall recognize that the emission limitation in paragraph (I)(1) of this rule is equivalent to 8.4 pounds VOC per gallon of deposited solids and is based upon a coating applicator transfer efficiency of sixty per cent. If the director approves an alternative emission limitation for a prime coat, topcoat, or single coat coating line for metal furniture, said limitation and the associated transfer efficiency shall be specified in the special terms and conditions of a operating permit or variance issued by the director for the coating line. If the test method for determining the transfer efficiency for a coating line has not been approved by the USEPA as part of the state implementation plan, the permit to operate or variance issued by the director for the coating line shall be approved by the USEPA as a revision to the state implementation plan.
- (3) Exemptions.
- (a) Exempted from paragraph (I)(1) of this rule are the prime coat, topcoat, or single coat coating lines for metal furniture at a facility, only if all such lines, in combination, emit less than fifteen pounds of VOC per day (before add-on controls).

(b) Exempted from paragraph (I)(1) of this rule is any application of a coating to a part not defined as metal furniture.

(4) In addition to paragraph (I)(1) of this rule the following requirements are applicable to all metal furniture coating lines located in Ashtabula, Butler, Clermont, Cuyahoga, Geauga, Hamilton, Lake, Lorain, Medina, Portage, ~~and~~ Summit, and Warren counties.

(a) Except as otherwise provided in paragraph (I)(4)(b) of this rule, no owner or operator of a coating line for metal furniture may cause, allow or permit the discharge into the ambient air of any VOCs after the date specified in paragraph (C)(8) of rule 3745-21-04 of the Administrative Code in excess of the VOC limitations specified in the following table:

VOC content (pound per gallon of coating, less water and exempt solvents)

Coating	Air-Dried Coating (controls not employed)	Baked Coating (controls not employed)
general one-component	2.3	2.3
general multi-component	2.8	2.3
solar-absorbent	3.5	3.0
heat-resistant	3.5	3.0
extreme high-gloss	2.8	3.0
metallic	3.5	3.5
extreme performance	3.5	3.0
pretreatment coatings	3.5	3.5

The recommended emission limits can also be expressed in terms of mass of VOC per volume of coating solids, as applied. A facility could use low-VOC coatings or a combination of coatings and add-on control equipment on a coating unit to meet the recommended mass of VOC per volume of coating solids limits. Using an assumed VOC density of 7.36 pounds per gallon, the equivalent limits in terms of mass of VOC per volume of solids, as applied, are as follows:

VOC content (pound per gallon of coating solids, as applied)

Coating	Air-Dried Coating (controls employed)	Baked Coating (controls employed)
general one-component	3.3	3.3
general multi-component	4.5	3.3
extreme high gloss	4.5	5.1
extreme performance	6.7	5.1
heat resistant	6.7	5.1
metallic	6.7	6.7
pretreatment coatings	6.7	6.7
solar absorbent	6.7	5.1

(b) Exemptions.

- (i) Exempted from paragraph (I)(4) of this rule are the coating lines for metal furniture at a facility, only if all such lines, in combination, emit less than fifteen pounds of VOC per day (before add-on controls).
- (ii) Exempted from paragraph (I)(4) of this rule is any application of coating to a part not defined as metal furniture.
- (iii) Paragraphs (I)(4)(a) and (I)(4)(d) of this rule ~~shall not apply~~ are not applicable to the following:
 - (a) Stencil coatings.
 - (b) Safety-indicating coatings.
 - (c) Solid-film lubricants.
 - (d) Touch-up and repair coatings.
 - (e) Coating application utilizing hand-held aerosol cans.

(c) Operating equipment.

A person shall not apply VOC-containing coatings to metal furniture unless the coating is applied with equipment operated according to the equipment manufacturer specifications, and by the use of one of the following methods:

- (i) Electrostatic application.
- (ii) Flow coat.
- (iii) Dip coat.
- (iv) Roll coat.
- (v) HVLP spray.
- (vi) Hand application methods.
- (vii) Such other coating application methods as are demonstrated to the director to be capable of achieving a transfer efficiency equivalent or better to the method listed in paragraph (I)(4)(c)(v) of this rule and for which written approval of the director has been obtained.

(d) Work practices for coating-related activities.

Unless emissions to the atmosphere are controlled by an approved emission control system with an overall control efficiency of at least ninety per cent, any person performing coating related activities shall do the following:

- (i) Store all VOC-containing coatings, thinners, and coating-related waste materials in closed containers.
- (ii) Ensure that mixing and storage containers used for VOC-containing coatings, thinners, and coating-related waste materials are kept closed at all times except when depositing or removing these materials.
- (iii) Minimize spills of VOC-containing coatings, thinners, and coating-related waste materials.
- (iv) Convey VOC-containing coatings, thinners, and coating-related waste materials from one location to another in closed containers or pipes.

(e) Work practice standards for cleaning materials.

Unless emissions to the atmosphere are controlled by an approved emission control system with an overall control efficiency of at least ninety per cent, any person using an organic solvent for cleanup shall do the following:

- (i) Store all VOC containing cleaning materials and used shop towels in closed containers.
- (ii) Ensure that mixing and storage containers used for VOC-containing cleaning materials are kept closed at all times except when depositing or removing these materials.
- (iii) Minimize spills of VOC-containing cleaning materials.
- (iv) Convey VOC-containing cleaning materials from one location to another in closed containers or pipes.
- (v) Minimize VOC emission from cleaning of storage, mixing, and conveying equipment.

(J) Except as otherwise provided in paragraph (B)(6) of this rule, no owner or operator of a magnet wire coating line may cause, allow or permit the discharge into the ambient air of any VOCs after the date specified in paragraph (C)(9) of rule 3745-21-04 of the Administrative Code in excess of 1.7 pounds of VOC per gallon of coating, excluding water and exempt solvents, or, if a control system is employed, 2.2 pounds of VOC per gallon of solids from a magnet wire coating line.

(K) Surface coating of large appliances.

- (1) Except as otherwise provided in paragraphs (B)(6), and (K)(2) to (K)(4) of this rule, no owner or operator of a prime coat, single coat or topcoat coating line for large appliances may cause, allow or permit the discharge into the ambient air of any VOCs after the date specified in paragraph (C)(10) of rule 3745-21-04 of the Administrative Code in excess of 2.8 pounds of VOC per gallon of coating, excluding water and exempt solvents, or, if a control system is employed, 4.5 pounds of VOC per gallon of solids from such prime coat, single coat, or topcoat coating line.
- (2) The emission limit under paragraph (K)(1) of this rule ~~shall~~ does not apply to the use of quick-drying lacquers for repair of scratches and nicks that occur during assembly, provided that the maximum usage of such lacquers does not exceed one quart in any eight-hour period.

- (3) Any owner or operator of a prime coat, single coat or topcoat coating line for large appliances may obtain from the director an alternative emission limitation for the limitation specified in paragraph (K)(1) of this rule. The owner or operator shall demonstrate to the satisfaction of the director, prior to obtaining an alternative emission limitation, that the alternative emission limitation is, at a minimum, equivalent in terms of total daily emissions of VOCs to the applicable requirement of paragraph (K)(1) of this rule. For purposes of this demonstration, the director shall recognize that the emission limitation in paragraph (K)(1) of this rule is equivalent to 7.5 pounds VOC per gallon of deposited solids and is based upon a coating applicator transfer efficiency of sixty per cent. If the director approves an alternative emission limitation for a prime coat, single coat or topcoat coating line for large appliances, said limitation and the associated transfer efficiency shall be specified in the special terms and conditions of an operating permit or variance issued by the director for the coating line. If the test method for determining the transfer efficiency for a coating line has not been approved by the USEPA as part of the state implementation plan, the permit to operate or variance issued by the director for the coating line shall be approved by the USEPA as a revision to the state implementation plan.
- (4) The emission limit under paragraph (K)(1) of this rule ~~shall~~does not apply to any large appliance coating line for which construction commenced prior to October 19, 1979 and which is located at the following facilities, unless a modification for any such coating line has commenced on or after October 19, 1979:
- (a) The "Whirlpool Findlay Division" (facility ID 0332010170) facility located at 4901 North Main street, Findlay, Ohio.
 - (b) The "Whirlpool Corporation (Marion Division)" (facility ID 0351010012) facility located at 1300 Marion-Agosta road, Marion, Ohio.
- (5) The emission limit under paragraph (K)(1) of this rule ~~shall~~does not apply to large appliance coatings that are subject to in-use temperatures in excess of two hundred fifty degrees Fahrenheit.
- (6) In addition to paragraph (K)(1) of this rule, the following are applicable to all surface coatings operations for large appliances located in Ashtabula, Butler, Clermont, Cuyahoga, Geauga, Hamilton, Lake, Lorain, Medina, Portage~~and~~, Summit, and Warren counties:
- (a) Except as otherwise provided in paragraph (K)(6)(b) of this rule, no owner or operator of a coating line for large appliances may cause, allow or permit the discharge into the ambient air of any VOCs after the date specified

in paragraph (C)(10) of rule 3745-21-04 of the Administrative Code in excess of the VOC limitations specified in the following table:

VOC content emission limitations (pounds per gallon of coating, less water and exempt solvents)

Coating Type	Air-Dried (controls not employed)	Baked Coating (controls not employed)
general one-component	2.3	2.3
general multi-component	2.8	2.3
solar-absorbent	3.5	3.0
heat-resistant	3.5	3.0
extreme high-gloss	2.8	3.0
metallic	3.5	3.5
extreme performance	3.5	3.0
pretreatment coatings	3.5	3.5

The recommended emission limits can also be expressed in terms of mass of VOC per volume of coating solids, as applied. A facility could use low-VOC coatings or a combination of coatings and add-on control equipment on a coating unit to meet the recommended mass of VOC per volume of coating solids limits. Using an assumed VOC density of 7.36 pounds per gallon, the equivalent limits in terms of mass of VOC per volume of solids, as applied, are as follows:

VOC content (pounds per gallon of coating solids, as applied)

Coating	Air-Dried Coating (controls employed)	Baked Coating (controls employed)
general one-component	3.3	3.3
general multi-component	4.5	3.3
extreme high gloss	4.5	5.1
extreme performance	6.7	5.1

heat resistant	6.7	5.1
metallic	6.7	6.7
pretreatment coatings	6.7	6.7
solar absorbent	6.7	5.1

(b) Exemptions.

- (i) Exempted from paragraph (K)(6) of this rule are coating lines for large appliances at a facility, only if all such lines, in combination, emit less than fifteen pounds of VOC per day (before add-on controls).
- (ii) Paragraphs (K)(6)(a) and (K)(6)(e) of this rule ~~shall~~ do not apply to the following:
 - (a) Stencil coatings.
 - (b) Safety-indicating coatings.
 - (c) Solid-film lubricants.
 - (d) Electric-insulating and thermal-conducting coatings.
 - (e) Touch-up and repair coatings.
 - (f) Coating application utilizing hand-held aerosol cans.

(c) Operating equipment.

A person shall not apply VOC-containing coatings to a large appliance unless the coating is applied with equipment operated according to the equipment manufacturer specifications, and by the use of one of the following methods:

- (i) Electrostatic application.
- (ii) Flow coat.
- (iii) Dip coat.
- (iv) Roll coat.
- (v) HVLP spray.

- (vi) Hand application methods.
- (vii) Such other coating application methods as are demonstrated to the director to be capable of achieving a transfer efficiency equivalent or better to the method listed in paragraph (K)(6)(c)(v) of this rule and for which written approval of the director has been obtained.

(d) Work practices for coating-related activities.

Unless emissions to the atmosphere are controlled by an approved emission control system with an overall control efficiency of at least ninety per cent, any person performing coating related activities shall do the following:

- (i) Store all VOC-containing coatings, thinners, and coating-related waste materials in closed containers.
- (ii) Ensure that mixing and storage containers used for VOC-containing coatings, thinners, and coating-related waste materials are kept closed at all times except when depositing or removing these materials.
- (iii) Minimize spills of VOC-containing coatings, thinners, and coating-related waste materials.
- (iv) Convey VOC-containing coatings, thinners, and coating-related waste materials from one location to another in closed containers or pipes.

(e) Work practice standards for cleaning materials.

Unless emissions to the atmosphere are controlled by an approved emission control system with an overall control efficiency of at least ninety per cent, any person using an organic solvent for cleanup shall do the following:

- (i) Store all VOC containing cleaning materials and used shop towels in closed containers.
- (ii) Ensure that mixing and storage containers used for VOC-containing cleaning materials are kept closed at all times except when depositing or removing these materials.
- (iii) Minimize spills of VOC-containing cleaning materials.

- (iv) Convey VOC-containing cleaning materials from one location to another in closed containers or pipes.
- (v) Minimize VOC emission from cleaning of storage, mixing, and conveying equipment.

(L) Storage of petroleum liquids in fixed roof tanks.

(1) No person shall place, store, or hold in a fixed roof tank any petroleum liquid with a true vapor pressure which is greater than 1.52 pounds per square inch absolute after the date specified in paragraph (C)(11) of rule 3745-21-04 of the Administrative Code unless such tank, is designed or equipped as follows, except where exempted under paragraph (L)(2) of this rule:

(a) Vapor control equipment which is one of the following:

(i) Internal floating roof.

(ii) Alternative equivalent control for VOC emissions as may be approved by the director.

(b) If equipped with an internal floating roof, the automatic bleeder vents are to be closed at all times except when the roof is floated off or landed on the roof leg supports, and the rim vents, if provided, are to be set to open when the roof is being floated off the roof leg supports or is at the manufacturer's recommended setting.

(c) All openings, except stub drains, are to be equipped with a cover, seal or lid which is to be in a closed position at all times except when in actual use for tank gauging or sampling.

(d) Other means for reducing the emission of VOC into the ambient air as may be required by the director.

(2) The following tanks are exempted from paragraph (L)(1) of this rule:

(a) Fixed roof tank with a capacity less than forty thousand gallons.

(b) Fixed roof tank with a capacity less than four hundred twenty-two thousand gallons and used to store produced crude oil and condensate prior to lease custody transfer.

(3) Any owner or operator of a fixed roof tank that is not exempted pursuant to paragraph (L)(2) of this rule shall maintain records of the following information

in a readily accessible location for at least five years and ~~shall~~ make copies of the records available to the director upon verbal or written request:

- (a) The types of petroleum liquids stored in the tank.
 - (b) The maximum true vapor pressure (in pounds per square inch absolute), as stored, of each liquid that has a maximum true vapor pressure greater 1.0 pound per square inch absolute.
- (4) If an owner or operator places, stores, or holds in a fixed roof tank, that is not exempted pursuant to paragraph (L)(2) of this rule, any petroleum liquid with a true vapor pressure which is greater than 1.52 pounds per square inch absolute and such tank does not comply with paragraph (L)(1) of this rule, the owner or operator shall ~~so~~ notify the director within thirty days of becoming aware of the occurrence.
- (M) Refinery vacuum producing systems, wastewater separators, and process unit turnarounds.
- (1) Each owner or operator of a petroleum refinery shall control the emissions of VOC from any vacuum producing systems no later than the date specified in paragraph (C)(12) of rule 3745-21-04 of the Administrative Code by piping the vapors to an appropriate firebox or incinerator, or by compressing the vapors and adding them to the refinery fuel gas system.
 - (2) Except for any wastewater separator which is used solely for once-through, noncontact cooling water or for intermittent tank farm drainage resulting from accumulated precipitation, each owner or operator of a petroleum refinery shall control the emissions of VOC from any wastewater separator no later than the date specified in paragraph (C)(13) of rule 3745-21-04 of the Administrative Code by equipping all forebay sections and other separator sections with covers and seals which minimize the amount of oily water exposed to the ambient air. In addition, all covers and forebay and separator sections shall be equipped with lids and seals which are kept in a closed position at all times except when in actual use.
 - (3) Process unit turnarounds.
 - (a) Each owner or operator of a petroleum refinery shall control the emissions of VOC from process unit turnarounds no later than the date specified in paragraph (C)(14) of rule 3745-21-04 of the Administrative Code by combusting the vapors as fuel gas or by flaring the vapors until the

pressure in the process vessel is 19.7 pounds per square inch absolute or less.

(b) Each owner or operator of a petroleum refinery shall maintain records for a minimum of two years for each process unit turnaround. ~~Such records shall include~~ including the following:

(i) The date the unit was shut down.

(ii) The approximate pressure of the vapors in the process vessel when the VOC emissions were first discharged to the ambient air.

(iii) The approximate total quantity of VOC emitted to the ambient air.

(N) Use of cutback asphalts and emulsified asphalts in road construction and maintenance.

(1) Except where exempted under paragraph (N)(3) of this rule, no person may allow or permit the use or application of cutback asphalts in road construction and maintenance after the date specified in paragraph (C)(15) of rule 3745-21-04 of the Administrative Code.

(2) Except where exempted under paragraph (N)(3) of this rule, no person may allow or permit the use or application of any emulsified asphalt in road construction and maintenance after the date specified in paragraph (C)(15) of rule 3745-21-04 of the Administrative Code unless the oil distillate content of such emulsified asphalt, as determined by ASTM ~~D244-09~~ D244, "Standard Test Methods and Practices for Emulsified Asphalt," is less than or equal to the following:

(a) 8.0 per cent by volume for an open-graded mix.

(b) 12.0 per cent by volume for a dense-graded mix.

(c) 3.0 per cent by volume for any use or application not regulated under paragraphs (N)(2)(a) and (N)(2)(b) of this rule.

(3) Paragraphs (N)(1) and (N)(2) of this rule ~~shall~~ do not apply to the following:

(a) During the period from October fifteenth through April fifteenth.

(b) To the use or application of a prime coat.

(c) To the use or application of any maintenance mix which is to be stockpiled for at least thirty days.

(d) To the use or application of any cutback asphalt or emulsified asphalt on an unpaved road for the purpose of dust control.

(4) Recordkeeping requirements.

(a) Any person using or applying a cutback asphalt or emulsified asphalt in road construction or maintenance during the period from April fifteenth through October fifteenth shall maintain the following records for each cutback asphalt or emulsified asphalt used or applied during that period:

(i) The type and quantity employed.

(ii) If an emulsified asphalt, the oil distillate content.

(iii) The date of application.

(iv) An identification of the road segments where applied.

(v) The type of application (e.g., prime coat, tack coat, seal coat, maintenance mix, crack sealing, dust control, etc.).

(vi) If the application is by hand for crack sealing, the quantity employed each day per work crew.

(b) The records required by paragraph (N)(4)(a) of this rule shall be maintained for a minimum of two years and ~~shall be made~~ available for review by the director or authorized representative during normal business hours.

(O) Solvent metal cleaning.

(1) Except where exempted under paragraph (O)(6) of this rule, paragraphs (O)(2); ~~(O)(3), and to~~ (O)(4) of this rule shall be satisfied no later than the dates specified in paragraph (C)(16) of rule 3745-21-04 of the Administrative Code.

(2) Each owner or operator of a cold cleaner shall do the following:

(a) Equip the cold cleaner with either of the following:

(i) A cover; and if the solvent has a vapor pressure greater than 0.3 pound per square inch absolute measured at one hundred degrees Fahrenheit, or the solvent is heated or agitated, the cover shall be designed and constructed so that ~~it~~ the cover can be easily operated with one hand.

- (ii) A remote solvent reservoir from which solvent is pumped through a nozzle suspended over a sink-like work area which drains back to the reservoir, provided the sink-like work area has an open drain area of less than sixteen square inches and provided the solvent neither is heated above one hundred twenty degrees Fahrenheit nor has a vapor pressure greater than 0.6 pound per square inch absolute, measured at one hundred degrees Fahrenheit.
- (b) Equip the cold cleaner with a device for draining the cleaned parts; and if the solvent has a vapor pressure greater than 0.6 pound per square inch absolute, measured at one hundred degrees Fahrenheit, the drainage facility shall be constructed internally so that parts are enclosed under the cover during draining unless an internal type drainage device cannot fit into the cleaning system.
- (c) Install one of the following devices if the solvent vapor pressure is greater than 0.6 pound per square inch absolute measured at one hundred degrees Fahrenheit, or if the solvent is heated above one hundred twenty degrees Fahrenheit:
 - (i) Freeboard that gives a freeboard ratio greater than or equal to 0.7.
 - (ii) Water cover (solvent shall be insoluble in and heavier than water).
 - (iii) Other systems of equivalent control, such as refrigerated chiller or carbon adsorption, approved by the director.
- (d) Operate and maintain the cold cleaner in accordance with the following practices to minimize solvent evaporation from the unit:
 - (i) Provide a permanent, legible, conspicuous label, summarizing the operating requirements.
 - (ii) Store waste solvent in covered containers.
 - (iii) Close the cover whenever parts are not being handled in the cleaner.
 - (iv) Drain the cleaned parts until dripping ceases.
 - (v) If used, supply a solvent spray that is a solid fluid stream (not a fine, atomized, or shower-type spray) at a pressure that does not exceed ten pounds per square inch gauge.
 - (vi) Clean only materials that are neither porous nor absorbent.

- (e) Notwithstanding the exemption specified in paragraph (O)(6)(b) of this rule, for each cold cleaner located in Ashtabula, Butler, Clark, Clermont, Cuyahoga, Geauga, Greene, Hamilton, Lake, Lorain, Medina, Miami, Montgomery, Portage, Summit, and Warren counties, comply with the following:
 - (i) The solvent material employed in the cold cleaner shall have a vapor pressure that does not exceed 1.0 mmHg (0.019 psi) measured at twenty degrees Celsius (sixty-eight degrees Fahrenheit).
 - (ii) The owner or operator of each cold cleaner shall maintain records for a minimum of five years that include the following information for each solvent purchased:
 - (a) The date of the purchase.
 - (b) The name, company identification, and chemical composition of the solvent.
 - (c) The vapor pressure of the solvent measured in mmHg at twenty degrees Celsius (sixty-eight degrees Fahrenheit), as determined by ASTM ~~D2879-10~~D2879, "Standard Test Method for Vapor Pressure-Temperature Relationship and Initial Decomposition Temperature of Liquids by Isoteniscope."
 - (iii) The cleaning of electronic components as defined in paragraph (G)(3) of rule 3745-21-01 of the Administrative Code are exempt from paragraph (O)(2)(e) of this rule.
 - (iv) The cleaning of paint gun parts, through the use of cold cleaners as defined in paragraph (G)(1) of rule 3745-21-01 of the Administrative Code, for the removal of paint and coatings, is exempt from paragraph (O)(2)(e) of this rule.
- (3) Each owner or operator of an open top vapor degreaser shall do the following:
- (a) Equip the open top vapor degreaser with a cover that can be opened and closed easily without disturbing the vapor zone.
 - (b) Install the following safety switches:
 - (i) A condenser thermostat or any other device which shuts off the sump heat if the condenser coolant is either not circulating or too warm.

- (ii) A spray safety switch which shuts off the spray pump if the vapor level drops below any fixed spray nozzle.
 - (iii) A vapor level control thermostat or any other device which shuts off the sump heat when the vapor level rises too high.
 - (iv) A water flow switch, water pressure switch or any other device which shuts off the sump heat if the water in a water-cooled condenser has no flow or no pressure, whichever is being monitored.
- (c) Install one of the following devices:
- (i) A freeboard with a freeboard ratio greater than or equal to 0.75, and if the open top vapor degreaser opening is greater than ten square feet, the cover shall be powered or equipped with mechanical features whereby it can be readily closed when the degreaser is not in use.
 - (ii) Refrigerated chiller.
 - (iii) Enclosed design (cover or door opens only when the dry part is actually entering or exiting the open top vapor degreaser).
 - (iv) Carbon adsorption system, with ventilation greater than or equal to fifty cubic feet per minute per square foot of air/solvent interface (when cover is open), and exhausting less than twenty-five parts per million of solvent averaged over one complete adsorption cycle.
 - (v) A control system, demonstrated to have control efficiency equivalent to or greater than any of the above, and approved by the director.
- (d) Operate and maintain the open top vapor degreaser in accordance with the following practices to minimize solvent evaporation from the unit:
- (i) Keep the cover closed at all times except when processing work loads through the degreaser.
 - (ii) Minimize solvent carryout by doing the following:
 - (a) Racking parts so that solvent drains freely and is not trapped.
 - (b) Moving parts in and out of the degreaser at less than eleven feet per minute.

- (c) Holding the parts in the vapor zone at least thirty seconds or until condensation ceases, whichever is longer.
 - (d) Tipping out any pools of solvent on the cleaned parts before removal from the vapor zone.
 - (e) Allowing parts to dry within the degreaser for at least fifteen seconds or until visually dry, whichever is longer.
- (iii) Clean only materials that are neither porous nor absorbent.
 - (iv) Occupy no more than one-half of the degreaser's open-top area with a workload.
 - (v) Always spray within the vapor level.
 - (vi) Repair solvent leaks immediately, or shut down the degreaser.
 - (vii) Store waste solvent only in covered containers.
 - (viii) Operate the cleaner such that water cannot be visually detected in solvent exiting the water separator.
 - (ix) ~~Use no~~Do not use ventilation fans near the degreaser opening.
 - (x) When the cover is open, do not expose the open top vapor degreaser to drafts greater than one hundred thirty-one feet per minute, as measured between three and six feet upwind and at the same elevation as the tank lip.
 - (xi) If a lip exhaust is used on the open top vapor degreaser, do not use a ventilation rate that exceeds sixty five cubic feet per minute per square foot of degreaser open area, unless a higher rate is necessary to meet occupational safety and health administration requirements.
 - (xii) Provide permanent, conspicuous label, summarizing the operating procedures.
- (4) Each owner or operator of a conveyORIZED degreaser shall do the following:
- (a) Install one of the following devices on all conveyORIZED degreasers having an air/solvent interface greater than twenty-two square feet:
 - (i) Refrigerated chiller.

- (ii) Carbon adsorption system, with ventilation greater than or equal to fifty cubic feet per minute per square foot of air/solvent interface (when downtime covers are open), and exhausting less than twenty-five parts per million of solvent by volume averaged over a complete adsorption cycle.
 - (iii) A system, demonstrated to have a control efficiency equivalent to or greater than paragraph (O)(4)(a)(i) or (O)(4)(a)(ii) of this rule, and approved by the director.
- (b) Equip the conveyORIZED degreaser with equipment, such as a drying tunnel or rotating (tumbling) basket, sufficient to prevent cleaned parts from carrying out solvent liquid or vapor.
- (c) Install the following safety switches, if the solvent is heated to its boiling point:
 - (i) A condenser flow switch and thermostat or any other device which shuts off the sump heat if the condenser coolant is either not circulating or too warm.
 - (ii) A spray safety switch which shuts off the spray pump if the vapor level drops below any fixed spray nozzle.
 - (iii) A vapor level control thermostat or any other device which shuts off the sump heat when the vapor level rises too high.
- (d) Equip the conveyORIZED degreaser with covers for closing off the entrance and exit when not in use, unless the conveyORIZED degreaser is equipped with a refrigerated chiller or carbon adsorption system that is always in use except during maintenance.
- (e) Operate and maintain the conveyORIZED degreaser in accordance with the following practice to minimize solvent evaporation from the unit:
 - (i) ~~Use no~~ Do not use workplace fans near the degreaser opening, and ensure that exhaust ventilation does not exceed sixty-five cubic feet per minute per square foot of degreaser opening, unless a higher rate is necessary to meet occupational safety and health administration requirements.
 - (ii) Minimize openings during operation so that entrances and exits silhouette workloads with an average clearance between the parts

and the edge of the degreaser opening of less than ten per cent of the width of the opening.

- (iii) Provide downtime covers for closing off the entrance and exit during shutdown hours.
 - (iv) Minimize carryout emission by doing the following:
 - (a) Racking parts so that solvent drains freely from parts and is not trapped.
 - (b) Maintaining the vertical conveyor speed at less than eleven feet per minute.
 - (v) Store waste solvent only in covered containers.
 - (vi) Repair solvent leaks immediately, or shut down the degreaser.
 - (vii) Operate the cleaner such that water cannot be visually detected in solvent exiting the water separator.
 - (viii) Place downtime covers over entrances and exits of the conveyORIZED degreaser at all times when the conveyors and exhausts are not being operated.
 - (ix) Clean only materials that are neither porous nor absorbent.
- (5) Any owner or operator of a solvent metal cleaning operation shall maintain records of the following information in a readily accessible location for at least five years and shall make these records available to the director upon verbal or written request:
- (a) All control equipment maintenance such as replacement of the carbon in a carbon adsorption unit.
 - (b) The results of all emission tests conducted to demonstrate compliance with paragraph (O)(3)(c)(iv), (O)(3)(c)(v), (O)(4)(a)(ii), or (O)(4)(a)(iii) of this rule.
 - (c) For cold cleaners, the types of solvents employed and the vapor pressure of each solvent (pounds per square inch absolute) measured at one hundred degrees Fahrenheit.
- (6) Exemptions:

- (a) Paragraph (O)(2)(d)(v) of this rule ~~shall~~ does not apply to cold cleaners that are research and development sources, as defined under section 3704.01 of the Revised Code, provided that the owner or operator maintains records which demonstrate that the combined VOC emissions from the exempted research and development sources are less than five tons per calendar year.
- (b) After June 15, 1999, except as provided in paragraph (O)(2)(e), paragraphs (O)(2) to (O)(5) of this rule ~~shall~~ do not apply to any solvent metal cleaning operation which is subject to 40 CFR part 63, subpart T, provided subpart T is specified in the terms and conditions of installation or operating permit issued by the director.
- (c) Where VOC-containing cleaners that exceed the vapor pressure requirements of paragraph (O)(2)(e)(i) of this rule are used to clean cured resin from application equipment, the cleaning of resin application equipment at facilities subject to and complying with 40 CFR part 63, subpart WWWW, is exempt from paragraph (O)(2)(e)(i) of this rule.
- (d) The cleaning of medical parts subject to regulation by the food and drug administration and metal parts subject to federal aviation administration and department of defense cleaning solvent specifications is exempt from paragraph (O)(2)(e)(i) of this rule provided a documented conflict between said specification and the vapor pressure requirements of paragraph (O)(2)(e)(i) of this rule occurs. ~~Such and~~ documentation ~~shall be~~ is provided to the appropriate Ohio EPA district office or local air agency.

(P) Bulk gasoline plant.

- (1) No owner or operator of a bulk gasoline plant may cause, allow or permit the transfer of gasoline at a bulk gasoline plant after the date specified in paragraph (C)(17) of rule 3745-21-04 of the Administrative Code unless the following are met, except where exempted under paragraph (P)(5) of this rule:
 - (a) Each stationary storage tank which stores gasoline at the bulk gasoline plant is loaded by means of a submerged fill pipe.
 - (b) For any transfer of gasoline from a delivery vessel to a stationary storage tank located at the bulk gasoline plant, the vapors displaced from the stationary storage tank are processed by one of the following systems:

- (i) A vapor balance system which is equipped with a vapor tight vapor line from the stationary storage tank to the delivery vessel and a means to ensure that the vapor line is connected before gasoline can be transferred and which is designed and operated to route at least ninety per cent by weight of the VOC in the displaced vapors to the delivery vessel.
 - (ii) A vapor control system which is designed and operated to recover at least ninety per cent by weight of the VOC in the displaced vapors.
- (c) Any loading rack at the bulk gasoline plant which transfers gasoline to a delivery vessel is equipped for top submerged filling or bottom filling for the transfer of gasoline.
- (d) For any transfer of gasoline from a loading rack located at the bulk gasoline plant to a delivery vessel, the vapors displaced from delivery vessel are processed by one of the following systems:
- (i) A vapor balance system which is equipped with a vapor tight vapor line from the delivery vessel to the stationary storage tank being unloaded and a means to ensure that the vapor line is connected before gasoline can be transferred and which is designed and operated to route at least ninety per cent by weight of the VOC in the displaced vapors to the stationary storage tank.
 - (ii) A vapor control system which is designed and operated to recover at least ninety per cent by weight of the VOC in the displaced vapors.
- (e) All gasoline loading lines, unloading lines and vapor lines are equipped with fittings which are vapor tight.
- (2) When a vapor balance system is employed to meet paragraph (P)(1)(b) or (P)(1)(d) of this rule, the following operating practices ~~shall be followed~~ are applicable:
- (a) The vapor balance system shall be kept in good working order and ~~shall be~~ used at all times during the transfer of gasoline.
 - (b) The delivery vessel hatches shall be closed at all times during the loading of the delivery vessel.
 - (c) There shall be no leaks in the delivery vessel pressure/vacuum relief valves and hatch covers.

- (d) There shall be no leaks in the vapor and liquid lines during the transfer of gasoline.
 - (e) The pressure relief valves on the stationary storage tanks and delivery vessels shall be set to release at no less than 0.7 pound per square inch gauge or the highest possible pressure (in accordance with state or local fire codes, or the "National Fire Protection Association" guidelines).
- (3) No owner or operator of a bulk gasoline plant may permit gasoline to be spilled, discarded in sewers, stored in open containers or handled in any other manner that would result in evaporation.
- (4) Any owner or operator of a bulk gasoline plant shall repair within fifteen days any leak from the vapor balance system or vapor control system which is employed to meet paragraph (P)(1) of this rule when such leak is equal to or greater than one hundred per cent of the lower explosive limit as propane, as determined under paragraph (K) of rule 3745-21-10 of the Administrative Code.
- (5) Exemptions.
- (a) Paragraphs (P)(1) to (P)(4) of this rule ~~shall not apply~~ are not applicable to a bulk gasoline plant which has an average daily throughput, based upon the number of days during a calendar year when the bulk plant was actually in operation, of less than four thousand gallons of gasoline.
 - (b) Paragraph (P)(1)(b) of this rule ~~shall not apply~~ is not applicable to any stationary storage tank which is equipped with either an internal floating roof or external floating roof.
- (6) Any owner or operator of a bulk gasoline plant shall maintain records of the following information in a readily accessible location for at least five years and ~~shall~~ immediately make these records available to the director upon verbal or written request:
- (a) The daily quantity of all gasoline loaded into gasoline tank trucks.
 - (b) The results of any leak checks, including, at a minimum, the following information:
 - (i) Date of inspection.
 - (ii) Findings (may indicate no leaks discovered or location, nature, and severity of each leak).

- (iii) Leak determination method.
- (iv) Corrective action (date each leak repaired and reasons for any repair interval in excess of fifteen calendar days).
- (v) Inspector's name and signature.

(7) Reporting requirements.

- (a) For any bulk gasoline plant that is exempted pursuant to paragraph (P)(5)(a) of this rule and has an average daily throughput equal to or greater than four thousand gallons per day, the owner or operator shall so notify the director within thirty days of becoming aware of the occurrence.
- (b) Any leaks in vapor or liquid lines that are not repaired within fifteen days after identification shall be reported to the director within thirty days after the repair is completed.

(Q) Bulk gasoline terminal.

- (1) Except where exempted under paragraph (Q)(4) of this rule, no owner or operator of a bulk gasoline terminal may cause, allow or permit the transfer of gasoline at a bulk gasoline terminal after the date specified in paragraph (C)(18) of rule 3745-21-04 of the Administrative Code unless the following are met:
 - (a) The loading rack is equipped with a vapor collection system whereby during the transfer of gasoline to any delivery vessel the following occurs:
 - (i) All vapors displaced from the delivery vessel during loading are vented only to the vapor collection system.
 - (ii) The pressure in the vapor collection system is maintained between minus six and plus eighteen inches of water gauge pressure.
 - (b) The loading rack is equipped with a vapor control system whereby the following occurs:
 - (i) All vapors collected by the vapor collection system are vented to the vapor control system.
 - (ii) The mass emissions of VOC from the vapor control system do not exceed 0.67 pound of VOC per thousand gallons (eighty milligrams of VOC per liter) of gasoline loaded into the delivery vessel.

- (iii) Any liquid gasoline returned to a stationary storage tank from the vapor control system is free of entrained air to the extent possible with good engineering design.
 - (c) A means is provided to prevent drainage of gasoline from the loading device when it is not in use or to accomplish complete drainage before the loading device is disconnected.
 - (d) All gasoline loading lines and vapor lines are equipped with fittings which are vapor tight.
 - (2) No owner or operator of a bulk gasoline terminal may permit gasoline to be spilled, discarded in sewers, stored in open containers or handled in any other manner that would result in evaporation.
 - (3) Any owner or operator of a bulk gasoline terminal shall repair within fifteen days any leak from the vapor collection system and vapor control system which are employed to meet paragraph (Q)(1) of this rule when such leak is equal to or greater than one hundred per cent of the lower explosive limit as propane, as determined under paragraph (K) of rule 3745-21-10 of the Administrative Code.
 - (4) Paragraph (Q)(1) of this rule ~~shall~~ does not apply to a bulk gasoline terminal which has a maximum daily throughput equal to or less than twenty thousand gallons of gasoline, provided either of the following:
 - (a) The gasoline is supplied to the loading rack only from stationary storage tanks, each of which is equipped with an internal floating roof or external floating roof.
 - (b) The loading rack is equipped with a vapor balance system that meets paragraphs (P)(1)(d)(i), (P)(2) and (P)(4) of this rule.
- (R) Gasoline dispensing facilities (stage I vapor control systems).
- (1) No owner or operator of a gasoline dispensing facility may cause, allow or permit the transfer of gasoline at a gasoline dispensing facility after the date specified in paragraph (C)(19) of rule 3745-21-04 of the Administrative Code unless the following are met, except where exempted under paragraph (R)(4) of this rule:
 - (a) Any stationary storage tank which stores gasoline at the gasoline dispensing facility is equipped with a submerged fill pipe.

- (b) For any transfer of gasoline from a delivery vessel to a stationary storage tank located at the gasoline dispensing facility, the vapors displaced from the stationary storage tank are processed by one of the following systems:
- (i) A vapor balance system which is designed and operated to route at least ninety per cent by weight of the VOC in the displaced vapors to the delivery vessel and which is equipped with a means to prevent the discharge of displaced vapors from an unconnected vapor line.
 - (ii) A vapor control system which is designed and operated to recover at least ninety per cent by weight of the VOC in the displaced vapors.
- (2) When a vapor balance system is employed to meet paragraph (R)(1)(b) of this rule, the following operating practices ~~shall be followed~~ are applicable:
- (a) ~~The~~ A vapor balance system ~~shall be~~ kept in good working order and ~~shall be~~ used at all times during the transfer of gasoline.
 - (b) ~~There shall be no leaks in the~~ Secure delivery vessel pressure/vacuum relief valves and hatch covers which do not leak.
 - (c) ~~There shall be no leaks in the~~ Secure vapor and liquid lines which do not leak during the transfer of gasoline.
- (3) Any owner or operator of a gasoline dispensing facility shall repair within fifteen days any leak from the vapor balance system or vapor control system which is employed to meet paragraph (R)(1) of this rule when such leak is equal to or greater than one hundred per cent of the lower explosive limit as propane, as determined under paragraph (K) of rule 3745-21-10 of the Administrative Code.
- (4) Paragraphs (R)(1) to (R)(3) of this rule ~~shall~~ do not apply to the following:
- (a) Any gasoline dispensing facility which has an annual throughput of less than one hundred twenty thousand gallons of gasoline.
 - (b) Transfers made to a stationary storage tank which is equipped with an internal floating roof or external floating roof.
- (5) Any owner or operator of a gasoline dispensing facility that is exempted from paragraphs (R)(1) to (R)(3) of this rule pursuant to paragraph (R)(4)(a) of this rule shall do the following: ~~maintain records of the quantity of gasoline delivered to the facility during each calendar month. The records shall be maintained at the facility for a period of three years. The owner or operator~~

~~shall notify the director if the annual gasoline throughput for any rolling twelve-month period is equal to or greater than one hundred twenty thousand gallons. The director shall be notified within forty-five days after the exceedance occurs.~~

(a) Maintain records of the quantity of gasoline delivered to the facility during each calendar month.

(b) Maintain records at the facility for a period of three years.

(c) Notify the director within forty-five days after the exceedance occurs if the annual gasoline throughput for any rolling twelve-month period is equal to or greater than one hundred twenty thousand gallons.

(S) "~~Alside, Inc. Associated Materials~~" (facility ID 1677000053) or any subsequent owner or operator of the "~~Alside, Inc. Associated Materials~~" facility located at 3773 State road, Cuyahoga Falls, Ohio shall not cause, allow or permit the discharge into the ambient air of any VOCs after the date specified in paragraph (C)(20) of rule 3745-21-04 of the Administrative Code in excess of the following:

- (1) 3.5 pounds of VOC per gallon of coating, excluding water and exempt solvents, from a siding (spray) coating line.
- (2) 3.5 pounds of VOC per gallon of coating, excluding water and exempt solvents, from a corner coating line.

(T) Leaks from petroleum refinery equipment.

(1) Except as otherwise provided in paragraphs (T)(1)(b) and (T)(1)(c) of this rule, each owner or operator of a petroleum refinery shall comply with the following monitoring, recordkeeping and reporting requirements no later than the date specified in paragraph (C)(27) of rule 3745-21-04 of the Administrative Code:

(a) Except as otherwise indicated in paragraph (T)(1)(b) of this rule, a monitoring program shall be developed and implemented which incorporates the following provisions:

- (i) Yearly monitoring of all pump seals, pipeline valves in liquid service and process drains in accordance with the method specified in paragraph (F) of rule 3745-21-10 of the Administrative Code.
- (ii) Quarterly monitoring of all compressor seals, pipeline valves in gas service and pressure relief valves in gas service in accordance with the method specified in paragraph (F) of rule 3745-21-10 of the Administrative Code.

- (iii) Monthly monitoring of all pump seals by visual methods.
 - (iv) Monitoring of any pump seal in accordance with the method specified in paragraph (F) of rule 3745-21-10 of the Administrative Code within five working days after any liquids are observed dripping from the seal.
 - (v) Monitoring of any relief valve in accordance with the method specified in paragraph (F) of rule 3745-21-10 of the Administrative Code within five working days after the valve has vented to the atmosphere.
 - (vi) Monitoring of any component in accordance with the method specified in paragraph (F) of rule 3745-21-10 of the Administrative Code within five working days after the repair of a leak.
- (b) Pressure relief devices which are connected to an operating flare header, vapor recovery devices, valves which are located in pipelines containing kerosene or heavier liquids, storage tank valves and valves which are not externally regulated are exempt from the monitoring requirements contained in paragraph (T)(1)(a) of this rule.
- (c) For any pipeline or pressure relief valves in gas or liquid service, an alternative monitoring schedule may be employed in lieu of the monitoring schedule specified in paragraph (T)(1)(a) of this rule as follows:
- (i) The valve is designated as difficult to monitor and is monitored each calendar year, provided the following conditions are met:
 - (a) Construction of the process unit commenced prior to March 27, 1981.
 - (b) The owner or operator of the valve demonstrates that the valve cannot be monitored without elevating the monitoring personnel more than six feet above a support surface.
 - (c) The owner or operator of the valve has a written plan that requires monitoring of the valve at least once per year.
 - (ii) The valve is designated as unsafe to monitor and is monitored as frequently as practical during safe to monitor times, provided the following conditions are met:

- (a) The owner or operator of the valve demonstrates that the valve is unsafe to monitor because monitoring personnel would be exposed to an immediate danger as a consequence of monitoring on a quarterly or yearly basis as specified in paragraph (T)(1)(a) of this rule.
- (b) The owner or operator of the valve adheres to a written plan that requires monitoring of the valve as frequently as practical during process unit turnarounds and other safe to monitor times.
- (d) All pipeline valves in gas service and pressure relief valves in gas service shall be clearly marked and identified in such a manner that they will be obvious to both refinery personnel performing monitoring and to the director.
- (e) If a leak is identified as a result of the monitoring program required by paragraph (T)(1)(a) of this rule and the concentration of VOC exceeds ten thousand parts per million by volume, a tag shall immediately be placed on the leaking component meeting the following: ~~The tag shall be readily visible and weatherproof; it shall bear an identification number; and it shall clearly indicate the date the leak was detected. The tag shall remain in place until the leaking component is repaired.~~
- (i) Readily visible and weatherproof.
- (ii) Bears an identification number.
- (iii) Clearly indicates the date the leak was detected.
- (iv) Remains in place until the leaking component is repaired.
- (f) A monitoring log shall be maintained for all leaking components which are tagged in accordance with paragraph (T)(1)(e) of this rule. ~~The monitoring log shall contain~~ containing, at a minimum, the following data:
- (i) The name of the process unit where the leaking component is located.
- (ii) The type of leaking component (such as valve, seal, or other component).
- (iii) The tag number of the leaking component.

- (iv) The date on which the leaking component was detected.
 - (v) The date on which the leaking component was repaired.
 - (vi) The date and results of the monitoring performed within five working days after the leaking component was repaired.
 - (vii) A record of the calibration of the monitoring instrument.
 - (viii) A list of those leaking components which cannot be repaired until the next process unit turnaround.
 - (ix) The total number of components monitored and the total number of components found leaking during the calendar year.
- (g) A copy of any monitoring log shall be retained by the owner or operator for a minimum of two years after the date on which the record was made or the report was prepared.
- (h) A copy of any monitoring log shall immediately be made available to the director or an authorized representative of the director, upon verbal or written request, at any reasonable time.
- (i) A report shall be submitted to the director by the fifteenth day of January, April, July and October that gives the total number of components monitored during the previous three calendar months, gives the total number of components found leaking during the previous three calendar months, identifies all components which were found leaking during the previous three calendar months but which were not repaired within fifteen days and identifies all leaking components which cannot be repaired until the next process unit turnaround.
- (2) Any owner or operator of a petroleum refinery shall repair and retest any leaking component, which is tagged and identified in accordance with paragraph (T) (1)(e) of this rule, as soon as possible but no later than fifteen days after the leak is found unless the leaking component cannot be repaired until a process unit turnaround occurs.
- (3) The director may require a process unit turnaround to occur earlier than the normally scheduled date if the number and severity of leaking components awaiting a turnaround warrant such action. Any such process unit turnaround shall be required by means of an order issued by the director to the owner or operator of the petroleum refinery pursuant to division (R) of section 3704.03 of the Revised Code.

- (4) The director may accept an alternative monitoring, recordkeeping and reporting program in lieu of paragraph (T)(1) of this rule if the owner or operator of a petroleum refinery can demonstrate to the satisfaction of the director that the alternative program is at least as effective in identifying, documenting and reporting leaks from petroleum refinery equipment as the program outlined in paragraph (T)(1) of this rule. For purposes of this paragraph, any proposed alternative monitoring, recordkeeping and reporting program that the director finds comparable to paragraph (DD)(12) or (DD)(13) of this rule or for any individual equipment component, finds equivalent to the federal requirements specified in 40 CFR part 60, subparts VV, VVa, GGG, GGGa and QQQ or 40 CFR part 63, subparts H and CC ~~shall be~~ acceptable to the director.

- (a) The alternative monitoring, recordkeeping and reporting program entitled "Lima Refining Company, LDAR Plan" and dated November 19, 2002 is approved by the director as an acceptable alternative program for the "Lima Refining Company" (facility ID 0302020012).

~~Pursuant to this paragraph, the alternative monitoring, recordkeeping and reporting program entitled "Lima Refining Company, LDAR Plan" and dated November 19, 2002 is approved by the director as an acceptable alternative program for the "Lima Refining Company" (facility ID 0302020012).~~

~~Pursuant to this paragraph, the alternative monitoring, recordkeeping and reporting program entitled "Request for Waiver of OAC 3745-21-09(T)(1)(a)(i) for Process Drains at BP-Husky Refining LLC, Toledo Refinery, Facility ID 04-48-02-0007" and dated November 23, 2015 is approved by the director as an acceptable alternative program for the "BP-Husky Refining LLC, Toledo Refinery" (facility ID 0448020007).~~

- (b) The alternative monitoring, recordkeeping and reporting program entitled "Request for Waiver of OAC 3745-21-09(T)(1)(a)(i) for Process Drains at BP-Husky Refining LLC, Toledo Refinery, Facility ID 04-48-02-0007" and dated November 23, 2015 is approved by the director as an acceptable alternative program for the "BP-Husky Refining LLC" (facility ID 0448020007).

(U) Surface coating of miscellaneous metal parts and products.

- (1) Except where exempted under paragraph (U)(2) of this rule, or otherwise provided in paragraph (B)(6) of this rule, no owner or operator of a miscellaneous metal part or product coating line ~~may~~shall cause, allow or permit the discharge into the ambient air of any VOCs from such coating line after the date specified in

paragraph (C)(28) of rule 3745-21-04 of the Administrative Code in excess of the following:

- (a) 4.3 pounds of VOC per gallon of coating, excluding water and exempt solvents, or, if a control system is employed, 10.3 pounds of VOC per gallon of solids for a clear coating.
- (b) 4.0 pounds of VOC per gallon of coating, excluding water and exempt solvents, or, if a control system is employed, 8.8 pounds of VOC per gallon of solids for a zinc rich primer coating.
- (c) 3.5 pounds of VOC per gallon of coating, excluding water and exempt solvents, or, if a control system is employed, 6.7 pounds of VOC per gallon of solids for an extreme performance coating.
- (d) 3.5 pounds of VOC per gallon of coating, excluding water and exempt solvents, or, if a control system is employed, 6.7 pounds of VOC per gallon of solids for any coating that is dried at temperatures not exceeding two hundred degrees Fahrenheit.
- (e) 4.3 pounds of VOC per gallon of coating, excluding water and exempt solvents, or, if a control system is employed, 10.3 pounds of VOC per gallon of solids for the interior coating of a steel pail or drum.
- (f) 3.5 pounds of VOC per gallon of coating, excluding water and exempt solvents, or, if a control system is employed, 6.7 pounds of VOC per gallon of solids for the exterior coating of a steel pail or drum.
- (g) 4.9 pounds of VOC per gallon of coating, excluding water and exempt solvents, for a glass adhesion body primer coating used for the installation of any glass windows during the assembly of automobiles and trucks.
- (h) 6.2 pounds of VOC per gallon of coating, excluding water and exempt solvents, or, if a control system is employed, 39.2 pounds of VOC per gallon of solids for a high performance architectural aluminum coating.
- (i) 3.0 pounds of VOC per gallon of coating, excluding water and exempt solvents, or, if a control system is employed, 5.1 pounds of VOC per gallon of solids for any coating that is not regulated under paragraphs (U)(1)(a) to (U)(1)(h) of this rule.

If a miscellaneous metal parts or products coating is subject to two or more limits as listed in paragraphs (U)(1)(a) to (U)(1)(i) of this rule, the limit which is least restrictive ~~shall apply~~ applies.

(2) Paragraph (U)(1) of this rule ~~shall not apply~~ is not applicable to the following:

- (a) The application of an exterior coating to marine vessels.
- (b) The application of an exterior coating to airplanes.
- (c) The repainting (refinishing) of used motor vehicles and trailers.
- (d) The application of a customized topcoat and any related customized single coat to motor vehicles, if the maximum number of motor vehicles is less than thirty-five per day.
- (e) Any miscellaneous metal parts or products coating line which never uses more than the following:
 - (i) For Clark, Greene, Miami, and Montgomery counties, eight gallons per day.
 - (ii) ~~For Butler, Clermont, Hamilton, and Warren counties, three gallons per day.~~ [Reserved.]
 - (iii) For all other counties, ten gallons per day.

The daily usage applicability levels specified in paragraphs (U)(2)(e)(i) to (U)(2)(e)(iii) of this rule ~~shall not apply~~ is not applicable to coatings employed by the metal parts or products coating line on parts or products which are not metal.

- (f) Any coating line that is a new source, as defined by rule 3745-31-01 of the Administrative Code and meets the following:
 - (i) The construction or modification of the coating line commenced on or after March 27, 1981.
 - (ii) The director has determined that the otherwise applicable emission limitation in paragraph (U)(1) of this rule is technically or economically infeasible and has established an alternative reasonably available control technology emission limitation. ~~The alternative limitation shall be~~ provided the alternative limit is the lowest emission limitation that the coating line is capable of meeting by the application of control technology that is reasonably available considering technological and economic feasibility. ~~The alternative limitation shall be~~ and is expressed as an emissions rate

(e.g., pounds VOC per gallon) or overall per cent reduction but ~~shall~~ not ~~be~~ in terms of mass per time (e.g., pounds per hour).

(iii) A final installation permit has been issued for the coating line pursuant to Chapter 3745-31 of the Administrative Code. ~~The installation permit shall contain~~ containing terms and conditions that specify the control requirement or emission limitation that is the basis for the director's alternative limitation determination for the coating line, as described in paragraph (U)(2)(f)(ii) of this rule.

(iv) USEPA has approved the alternative limitation as a revision to the Ohio state implementation plan.

(g) The application of a coating which is subject to paragraph (C), (D), (E), (I), (J), (K), (S), (FF) or (OO) of this rule.

(h) Any facility which always emits less than fifteen pounds of VOC per day (before add-on controls) from all miscellaneous metal parts or products coating lines within the facility (pounds of VOC attributed to metal parts or products coating lines in which non-metal parts or products were being coated ~~shall not count~~ is exempt from counting towards this daily limit).

(3) At automobile and light-duty truck assembly plants, paragraph (U)(1) of this rule also shall apply to the application of underbody antichip materials (e.g., underbody plastisol) and to metal surface coating operations other than prime, prime surfacer, topcoat, and final repair operations.

(V) Gasoline tank trucks.

(1) Except where exempted under paragraph (V)(3) of this rule, each owner or operator of a gasoline tank truck shall comply with the following by the date specified in paragraph (C)(29) of rule 3745-21-04 of the Administrative Code:

(a) No gasoline tank truck is to be used for the transfer of gasoline, unless within the previous twelve months it was tested for leaks in accordance with the applicable method specified in paragraph (G) of rule 3745-21-10 of the Administrative Code.

(b) Any gasoline tank truck which, when last tested for leaks, failed to meet all requirements of the applicable method specified in paragraph (G) of rule 3745-21-10 of the Administrative Code is not to be used for the transfer of gasoline.

- (c) A record is to be maintained of all gasoline tank trucks which are tested in accordance with paragraph (G) of rule 3745-21-10 of the Administrative Code, and such record is to contain, at a minimum, the following data:
- (i) The tank identification number (manufacturer's serial number or owner's identification number).
 - (ii) The calendar year during which the tank was manufactured.
 - (iii) The date and location of the test.
 - (iv) The name, title and telephone number of the person who conducted the test, and the name and address of the company where the person is employed.
 - (v) The following information from the test:
 - (a) The tank pressure for the start of the pressure test.
 - (b) The tank pressure for the end of the pressure test.
 - (c) The tank pressure for the start of the vacuum test.
 - (d) The tank pressure for the end of the vacuum test.
 - (e) The resultant pressure changes for the pressure test and the vacuum test.
 - (vi) A list of all repairs which were made ~~to the gasoline tank truck~~ to enable the gasoline tank truck to pass all applicable requirements of the test.
- (d) A copy of the test record required in paragraph (V)(1)(c) of this rule is to be retained by the owner or operator of the tank truck for a minimum of two years after the date on which the test was conducted.
- (e) A copy of the test record required in paragraph (V)(1)(c) of this rule is to immediately be made available to the director, or an authorized representative of the director, upon verbal or written request, at any reasonable time.
- (f) No gasoline tank truck is to be used for the transfer of gasoline, unless paragraphs (V)(1)(a) and (V)(1)(b) of this rule can be readily verified by means of either of the following:

- (i) A copy of the test record required in paragraph (V)(1)(c) of this rule is kept in the gasoline tank truck.
 - (ii) A sticker, which contains the tank identification number, the calendar year during which the tank was manufactured, the date the tank last passed the applicable test method specified in paragraph (G) of rule 3745-21-10 of the Administrative Code and the name and location of the testing company or department, is prominently displayed on the right side of the front of the tank.
- (g) Any gasoline tank truck which has a leak which is equal to or greater than one hundred per cent of the lower explosive limit as propane, as determined under paragraph (K) of rule 3745-21-10 of the Administrative Code, is not to be used for the transfer of gasoline after fifteen days from the detection of such leak unless the leak is repaired.
- (h) Whenever any gasoline tank truck is removed from service for routine maintenance and repairs, ~~the gasoline tank truck shall also be inspected/ repaired in accordance with~~ the following inspection and repair procedures apply:
- (i) Inspect all dome cover gaskets to ensure they will properly seal against vapor releases. Any dome cover gasket shall be replaced if ~~its~~the integrity is in doubt.
 - (ii) Open and close all dome covers to ensure that the latch tension is such that the cover will be held securely closed to prevent vapor releases. Any dome covers with inadequate latch tension shall be repaired or replaced.
 - (iii) Inspect the fusible plugs in each dome cover assembly to ensure proper tightness. Any fusible plugs which are found to be loose or defective shall be tightened or replaced.
 - (iv) Inspect each vapor vent hood and sealing band for defects. If any defects are found, the defective vapor vent hood or sealing band shall be replaced with new components.
 - (v) Inspect all vapor return hoses and any associated fittings and adaptors for defects that could allow vapor releases. If defects are found, the defective equipment shall be repaired or replaced.
 - (vi) Inspect any pressure and vacuum relief vents located on the vapor recovery line to ensure that they are clean and in proper working

order. If a relief vent is found to be defective, it shall be repaired or replaced.

- (i) No gasoline tank truck is to be used for the transfer of gasoline at a bulk gasoline terminal, bulk gasoline plant or gasoline dispensing facility that employs a vapor balance system or vapor control system unless the transfer is done in a manner that ensures the proper operation of the vapor balance system or vapor control system.
- (2) The director may require any gasoline tank truck to be tested in accordance with the applicable method specified in paragraph (G) of rule 3745-21-10 of the Administrative Code within a reasonable period of time. Any such test shall be required by means of an order issued by the director to the owner or operator of the gasoline tank truck pursuant to division (R) of section 3704.03 of the Revised Code.
- (3) Exempted from paragraphs (V)(1) and (V)(2) of this rule is any gasoline tank truck which has a capacity of less than five thousand gallons, unless the gasoline tank truck does either of the following:
 - (a) Receives gasoline from any loading rack which is equipped with a vapor balance system or vapor control system.
 - (b) Delivers gasoline to any stationary storage tank which is equipped with a vapor balance system.

(W) Synthesized pharmaceutical manufacturing facility.

- (1) Except where exempted under paragraph (W)(2) of this rule, each owner or operator of a synthesized pharmaceutical manufacturing facility shall comply with the following no later than the date specified in paragraph (C)(30) of rule 3745-21-04 of the Administrative Code:
 - (a) Except for any VOC emissions which are collected by a production equipment exhaust system, the discharge of VOC emissions into the ambient air from any reactor, distillation operation, crystallizer, centrifuge or vacuum dryer is to be controlled by one of the following devices:
 - (i) A surface condenser which has an outlet gas concentration of VOC not exceeding fifty thousand parts per million by volume.

- (ii) A device or system which is, in the judgment of the director, at least as effective in controlling VOC emissions as the above-mentioned surface condenser.
- (b) The discharge of VOC emissions into the ambient air from any air dryer or production equipment exhaust system is not to exceed thirty-three pounds in any one day, unless said discharge has been reduced by at least ninety per cent on a weight basis by control equipment.
- (c) Except as otherwise provided in paragraph (L) of this rule, any storage tank which holds a VOC that has a vapor pressure greater than 1.5 pounds per square inch absolute at sixty-eight degrees Fahrenheit is to be equipped with one of following devices:
 - (i) A conservation vent which opens at a pressure of 0.5 ounce per square inch or higher and at a vacuum of 0.5 ounce per square inch or higher.
 - (ii) A device or system which is, in the judgment of the director, at least as effective in controlling VOC emissions as the above-mentioned conservation vent.
- (d) During any transfer of a VOC, which has a vapor pressure greater than 4.1 pounds per square inch absolute at sixty-eight degrees Fahrenheit, from a truck or railcar to a fixed roof tank which has a capacity greater than two thousand gallons, the vapors displaced from said tank are to be processed by one of the following systems:
 - (i) A vapor balance system which is designed and operated to route at least ninety per cent by weight of the VOC in the displaced vapors to the truck or railcar.
 - (ii) A vapor control system which is designed and operated to recover at least ninety per cent by weight of the VOC in the displaced vapors.
- (e) Any centrifuge containing a VOC, any rotary vacuum filter processing a VOC and any other filter having an exposed liquid VOC surface, are to be enclosed if the VOC has a vapor pressure greater than 0.5 pound per square inch absolute at sixty-eight degrees Fahrenheit.
- (f) Any in-process tank which contains a VOC is to be equipped with a cover which remains closed, except when production, sampling, maintenance or inspection procedures require access to said tank.

(g) Any leak in which a VOC is observed to be running or dripping from a vessel or other equipment is to be repaired as soon as possible, but no later than the first time said equipment is off line for a period of time long enough to complete the repair.

(2) Exempted from paragraph (W)(1) of this rule is any operation or equipment not associated with the production of drugs.

(X) Rubber tire manufacturing facility.

(1) Except where exempted under paragraph (X)(2) of this rule, each owner or operator of a rubber tire manufacturing facility shall comply with the following no later than the date specified in paragraph (C)(31) of rule 3745-21-04 of the Administrative Code:

(a) Each undertread cementing, tread end cementing and bead dipping operation is to be equipped with a capture system and associated control system which are designed and operated with the following efficiencies for VOCs, as determined under paragraph (C) of rule 3745-21-10 of the Administrative Code:

(i) A capture efficiency which is at least eighty-five per cent by weight.

(ii) A control efficiency which is at least ninety per cent by weight.

(b) Except as otherwise provided in paragraph (X)(1)(c) of this rule, each green tire spraying operation is to be equipped with a capture system and associated control system which are designed and operated with the following efficiencies for VOCs, as determined under paragraph (C) of rule 3745-21-10 of the Administrative Code:

(i) A capture efficiency which is at least ninety per cent by weight.

(ii) A control efficiency which is at least ninety per cent by weight.

(c) Paragraph (X)(1)(b) of this rule does not apply to any green tire spraying operation in which the VOC content of the material sprayed, as determined in accordance with paragraph (B) of rule 3745-21-10 of the Administrative Code, is a maximum daily weighted average of six per cent or less by weight for material sprayed on the inside of a tire and eleven per cent or less by weight for material sprayed on the outside of a tire.

(2) The following operations are exempt from the requirements of paragraph
~~Paragraph (X)(1) of this rule; shall not apply to the following operations:~~

(a) Any operation not associated with rubber tires of the following size:

(i) A bead diameter less than or equal to 20.0 inches.

(ii) A cross-sectional dimension less than or equal to 12.8 inches.

(b) Any operation for which construction commenced prior to March 27, 1981 at the "The Cooper Tire Company - Findlay" (facility ID 0332010003) facility located at 701 Lima avenue, Findlay, Ohio, unless a modification for any such operation has commenced on or after March 27, 1981.

(c) Any operation that produces specialty tires for antique or other vehicles when produced on an irregular basis or with short production runs. (This exemption applies only to tires produced on equipment separate from normal production lines for passenger-type tires.)

(d) Any operation subject to the federal "Standards of performance for new stationary sources, 40 CFR part 60, subpart BBB."

(Y) Flexographic, packaging rotogravure and publication rotogravure printing lines.

(1) Except where exempted under paragraph (Y)(2) of this rule, no owner or operator of a flexographic printing line, packaging rotogravure printing line or publication rotogravure printing line may cause, allow or permit the discharge into the ambient air of any VOCs from such printing line after the date specified in paragraph (C)(32) of rule 3745-21-04 of the Administrative Code unless either paragraph (Y)(1)(a) or (Y)(1)(b) of this rule are satisfied.

(a) The VOC content of the coatings and inks employed in said printing line, as determined under paragraph (B) of rule 3745-21-10 of the Administrative Code, does not exceed either of the following limitations:

(i) Forty per cent VOC by volume of the coating and ink, excluding water and exempt solvents.

(ii) Twenty-five per cent VOC by volume of the volatile matter in the coating and ink.

(b) Said printing line is equipped with a capture system and associated control system which are designed and operated to achieve the following

efficiencies for volatile organic compounds, as determined under paragraph (C) of rule 3745-21-10 of the Administrative Code:

(i) A capture efficiency, as follows:

(a) At least sixty-five per cent by weight, for a flexographic printing line.

(b) At least seventy per cent by weight, for a packaging rotogravure printing line.

(c) At least eighty per cent by weight, for a publication rotogravure printing line.

(ii) A control efficiency which is at least ninety per cent by weight.

(2) Paragraph (Y)(1) of this rule ~~shall not apply~~ is not applicable to the following:

(a) Any printing line that is subject to and in compliance with the emission limitations in paragraph (H) of this rule, which pertains to vinyl coating.

(b) Any printing line which is located at a facility in which the total maximum usage of coatings and inks in all flexographic, packaging rotogravure and publication rotogravure printing lines is less than or equal to one hundred forty-eight tons per year; except as otherwise provided under paragraph (Y)(3) of this rule.

(c) Any printing line which is used solely to check the quality of the image formation of newly engraved or etched cylinders.

(d) Any printing line which is located at a facility in which the total maximum usage of VOC in all coatings and inks employed in all flexographic, packaging rotogravure and publication rotogravure printing lines within the facility is less than or equal to one hundred tons per year, except as otherwise provided under paragraph (Y)(3) of this rule.

(3) Once paragraph (Y)(1) of this rule applies to a facility or a flexographic, packaging rotogravure and publication rotogravure printing line within the facility, the facility is not eligible for an exemption under paragraphs (Y)(2)(b) and (Y)(2)(d) of this rule.

(4) In addition to paragraph (Y)(1) of this rule the following are applicable to all packaging rotogravure printing lines and flexographic packaging printing lines

located in Ashtabula, Butler, Clermont, Cuyahoga, Hamilton, Geauga, Lake, Lorain, Medina, Portage ~~and Summit~~ or Warren counties:

(a) Any owner or operator of a packaging rotogravure printing line or flexographic packaging printing line with potential emissions that are equal to or greater than 25.0 tons per year of VOC before the application of capture and control devices shall comply with either of the following for the printing line:

(i) Employ a control system in order to reduce VOC emissions from the packaging rotogravure printing line that meets one of the following:

(a) For a packaging rotogravure printing line, publication rotogravure printing line, or flexographic printing line located in Ashtabula, Cuyahoga, Geauga, Lake, Lorain, Medina, Portage, or Summit county:

~~(a)~~(i) Sixty-five per cent overall control for a press that was first installed prior to March 14, 1995 and that is controlled by an add-on air pollution control device whose first installation date was prior to April 2, 2009.

~~(b)~~(ii) Seventy per cent overall control for a press that was first installed prior to March 14, 1995 and that is controlled by an add-on air pollution control device whose first installation date was on or after April 2, 2009.

~~(c)~~(iii) Seventy-five per cent overall control for a press that was first installed on or after March 14, 1995 and that is controlled by an add-on air pollution control device whose first installation date was prior to April 2, 2009.

~~(d)~~(iv) Eighty per cent overall control for a press that was first installed on or after March 14, 1995 and that is controlled by an add-on air pollution control device whose first installation date was on or after April 2, 2009.

(b) For a packaging rotogravure printing line, publication rotogravure printing line, or flexographic printing line located in Butler, Clermont, Hamilton or Warren county:

(i) Sixty-five per cent overall control for a press that was first installed prior to March 14, 1995 and that is controlled by an add-on air pollution control device whose first installation date was prior to the effective date of this rule.

(ii) Seventy per cent overall control for a press that was first installed prior to March 14, 1995 and that is controlled by an add-on air pollution control device whose first installation date was on or after the effective date of this rule.

(iii) Seventy-five per cent overall control for a press that was first installed on or after March 14, 1995 and that is controlled by an add-on air pollution control device whose first installation date was prior to the effective date of this rule.

(iv) Eighty per cent overall control for a press that was first installed on or after March 14, 1995 and that is controlled by an add-on air pollution control device whose first installation date was on or after the effective date of this rule.

(ii) Employ coatings in the packaging rotogravure printing line or flexographic packaging printing line that comply with either of the following VOC content limitations:

(a) 0.8 pound of VOC per pound of solids applied.

(b) 0.16 pound of VOC per pound of coating or ink applied.

The VOC content limits specified above can be met by averaging the VOC content of materials used on a single press, within a single printing line.

(b) Work practice standards for cleaning materials.

Any person or facility subject to this rule that uses VOC-containing clean-up materials shall ensure that VOC emissions are minimized by incorporating the following procedures:

(i) Keep cleaning materials and used shop towels in closed containers.

- (ii) Convey cleaning materials from one location to another in closed containers or pipes.

(Z) Storage of petroleum liquids in external floating roof tanks.

(1) Except where exempted under paragraph (Z)(3) of this rule, no owner or operator of an external floating roof tank shall place, store, or hold any petroleum liquid in any such tank after the date specified in paragraph (C)(33) of rule 3745-21-04 of the Administrative Code, unless the tank is designed or equipped as follows:

(a) The tank is equipped with one of the following:

- (i) A liquid-mounted primary seal and a rim-mounted secondary seal.
- (ii) A mechanical shoe primary seal and a rim-mounted secondary seal.
- (iii) A mechanical shoe primary seal and a shoe-mounted secondary seal, provided the shoe-mounted secondary seal was installed prior to January 1, 1981.
- (iv) A vapor-mounted primary seal and a rim-mounted secondary seal.
- (v) A flexible wiper primary seal and a rim-mounted secondary seal.
- (vi) A liquid-mounted primary seal or a mechanical shoe primary seal, provided the petroleum liquid is crude oil with a pour point of fifty degrees Fahrenheit or higher as determined by ASTM ~~D97-11~~D97.
- (vii) A seal, closure or device which is, in the judgment of the director, equivalent to either of the following seals in controlling the emission of VOC into the ambient air:
 - (a) The dual seals specified in paragraph (Z)(1)(a)(i) or (Z)(1)(a)(ii) of this rule.
 - (b) Either of the seals specified in paragraph (Z)(1)(a)(vi) of this rule, provided the petroleum liquid is crude oil with a pour point of fifty degrees Fahrenheit or higher as determined by ASTM ~~D97-11~~D97.

(b) Each seal meets the following:

- (i) There are no visible holes, tears, or other openings in the seal or seal fabric.

- (ii) If the tank is of welded construction, the total seal gap area, as determined under paragraph (I) of rule 3745-21-10 of the Administrative Code, does not exceed any of the following:
 - (a) 10.0 square inches per foot of tank diameter for a liquid-mounted primary seal or mechanical shoe primary seal.
 - (b) 10.0 square inches per foot of tank diameter for a vapor-mounted primary seal or flexible wiper primary seal, if said seal was installed prior to January 1, 1981.
 - (c) 1.0 square inch per foot of tank diameter for a vapor-mounted primary seal or flexible wiper primary seal, if said seal was installed on or after January 1, 1981.
 - (d) 1.0 square inch per foot of tank diameter for a rim-mounted secondary seal or shoe-mounted secondary seal.
 - (e) The amount which is assigned by the director for any seal which is equivalent under paragraph (Z)(1)(a)(vii) of this rule.
- (iii) If the tank is of riveted construction, the maximum seal gap width, as determined under paragraph (I) of rule 3745-21-10 of the Administrative Code, does not exceed the following:
 - (a) 2.5 inches for a mechanical shoe primary seal.
 - (b) 1.5 inches for a liquid-mounted primary seal, vapor-mounted primary seal, flexible wiper primary seal, shoe-mounted secondary seal or rim-mounted secondary seal.
 - (c) The amount which is assigned by the director for any seal which is equivalent under paragraph (Z)(1)(a)(vii) of this rule.
- (c) Any opening in the external floating roof, except automatic bleeder vents, rim space vents, leg sleeves, stub drains and slotted gauging/sampling wells, is equipped with the following:
 - (i) A cover, seal or lid which remains in the closed position at all times without any visible gaps, except when the opening is in actual use.
 - (ii) A projection into the tank below the liquid surface.

- (d) Any automatic bleeder vent remains in the closed position, except when the external floating roof is floated off or landed on the roof leg supports.
 - (e) Any rim vent is set to open only at the manufacturer's recommended setting, except when the external floating roof is being floated off the roof leg supports.
 - (f) Any emergency roof drain is equipped with a slotted membrane fabric cover or other device which covers at least ninety per cent of the area of the opening.
 - (g) Any stub drain is equipped with a projection into the tank below the liquid surface.
 - (h) Any slotted gauging/sampling well is equipped with an object which floats on the liquid surface within the well and which covers at least ninety per cent of the area of the well opening.
- (2) Except where exempted under paragraph (Z)(3) of this rule, each owner or operator of an external floating roof tank which contains a petroleum liquid shall meet the following inspection, recordkeeping and reporting requirements:
- (a) Inspect annually and seal and seal fabric for compliance with paragraph (Z)(1)(b)(i) of this rule.
 - (b) Measure annually, in accordance with the method specified in paragraph (I) of rule 3745-21-10 of the Administrative Code, the secondary seal gap or the primary seal gap, if there is no secondary seal, for compliance with the seal gap requirements of paragraph (Z)(1)(b)(ii) or (Z)(1)(b)(iii) of this rule.
 - (c) Measure at least once every five years, in accordance with the method specified in paragraph (I) of rule 3745-21-10 of the Administrative Code, the primary seal gap, if there is a secondary seal, for compliance with the seal gap requirements of paragraph (Z)(1)(b)(ii) or (Z)(1)(b)(iii) of this rule.
 - (d) Maintain for at least two years a record of the following:
 - (i) The dates and results of any inspections or measurements performed in accordance with paragraphs (Z)(2)(a) to (Z)(2)(c) of this rule.
 - (ii) The annual throughput of any petroleum liquid stored in the tank.

- (e) Provide immediately to the director or an authorized representative of the director, upon written or verbal request at any reasonable time, a copy of the record required under paragraph (Z)(2)(d) of this rule.
- (3) The following external floating roof tanks ~~shall be~~ are exempted from paragraphs (Z)(1) and (Z)(2) of this rule:
- (a) Any tank which has a capacity of less than forty thousand gallons.
 - (b) Any tank which has a capacity of less than four hundred twenty thousand gallons and which is used to store produced crude oil or condensate prior to custody transfer.
 - (c) Any tank which contains a petroleum liquid which, as stored, has a maximum true vapor pressure less than 1.5 pounds per square inch absolute.
- (4) Any owner or operator of an external floating roof tank that is not exempted pursuant to paragraph (Z)(3)(a) or (Z)(3)(b) of this rule shall maintain records of the following information in a readily accessible location for at least five years and ~~shall~~ make copies of the records available to the director upon verbal or written request:
- (a) The types of petroleum liquids stored in the tank.
 - (b) The maximum true vapor pressure (pounds per square inch absolute), as stored, of each liquid that has a maximum true vapor pressure greater than 1.0 pound per square inch absolute.
- (5) If an owner or operator places, stores, or holds in an external floating roof tank, that is not exempted pursuant to paragraph (Z)(3)(a) or (Z)(3)(b) of this rule, any petroleum liquid with a true vapor pressure which is greater than 1.5 pounds per square inch absolute and such tank does not comply with paragraph (Z)(1) of this rule, the owner or operator shall so notify the director within thirty days of becoming aware of the occurrence.

(AA) Perchloroethylene dry cleaning facility.

- (1) Except where exempted under paragraph (AA)(2) of this rule, no owner or operator of a perchloroethylene dry cleaning facility may cause, allow or permit the cleaning of articles in perchloroethylene on or after June 14, 1991 unless the following is met:

- (a) Any dryer which contains articles cleaned in perchloroethylene is to be equipped and operated in accordance with one of the following:
 - (i) Any exhaust from the dryer is vented through a carbon adsorber which emits no more than one hundred parts per million by volume of perchloroethylene at any time.
 - (ii) The dryer is equipped with or vented to a refrigerated vapor condenser whereby there is no exhaust of perchloroethylene vapors to the ambient air throughout the drying cycle, except for when the dryer's door is momentarily opened during loading or unloading.
- (b) The waste from any diatomaceous earth filter which has been used to filter perchloroethylene is to contain no more than twenty-five per cent by weight perchloroethylene, as determined under paragraph (J) of rule 3745-21-10 of the Administrative Code.
- (c) The waste from any distillation operation (solvent still) which has been used to distill perchloroethylene is to contain no more than sixty per cent by weight perchloroethylene, as determined under paragraph (J) of rule 3745-21-10 of the Administrative Code.
- (d) Any disposable filter cartridge which has been used to filter perchloroethylene is to be drained in the filter housing for at least twenty-four hours before being discarded.
- (e) All equipment shall be maintained so as to prevent the leaking of perchloroethylene liquid and prevent perceptible vapor leaks from gaskets, seals, ducts, and related equipment. Any equipment which is leaking perchloroethylene liquid or has a perceptible vapor leak is not to be operated until the leak is repaired.

(2) Exemptions.

- (a) Paragraphs (AA)(1)(a) to (AA)(1)(e) of this rule ~~shall not apply~~ are not applicable to any dry cleaning operation which is coin-operated.
- (b) Paragraph (AA)(1)(a) of this rule ~~shall not apply~~ is not applicable to any facility in which the owner or operator has satisfactorily demonstrated that a carbon adsorber or refrigerated condenser cannot be installed because of inadequate space.

- (c) Paragraph (AA)(1)(a) of this rule ~~shall not apply~~ is not applicable to any facility in which the annual amount of fabric dry cleaned with perchloroethylene is less than sixty thousand pounds.
- (3) Compliance with paragraph (AA)(1)(e) of this rule shall be determined by means of visual inspection of the following components:
- (a) Hose connections, unions, couplings, and valves.
 - (b) Machine door gaskets and seatings.
 - (c) Filter head gasket and seating.
 - (d) Pumps.
 - (e) Base tanks and storage containers.
 - (f) Water separators.
 - (g) Filter sludge recovery.
 - (h) Distillation unit.
 - (i) Diverter valves.
 - (j) Saturated lint from lint basket.
 - (k) Cartridge filters.
- (4) Each owner or operator of a perchloroethylene dry cleaning facility shall maintain the following records in a readily accessible location for at least three years and ~~shall~~ make these records available to the director or an authorized representative of the director at any reasonable time:
- (a) A record of control equipment maintenance, such as replacement of the carbon in a carbon adsorption unit.
 - (b) A record of the results of visual leak inspections conducted in accordance with paragraph (AA)(3) of this rule.
 - (c) The results of all tests conducted to determine compliance with the limitations contained in paragraphs (AA)(1)(a)(i), (AA)(1)(b), and (AA)(1)(c) of this rule.

- (d) The annual usage of perchloroethylene, in gallons, and the annual amount of fabric dry cleaned with perchloroethylene, in pounds.

(BB) Petroleum dry cleaning facility.

(1) Except where exempted under paragraph (BB)(3) of this rule, no owner or operator of a petroleum dry cleaning facility may cause, allow or permit the cleaning of articles in petroleum solvent after the date specified in paragraph (C)(36) of rule 3745-21-04 of the Administrative Code unless the following is met:

(a) Any dryer for articles cleaned in petroleum solvent shall comply with one of the following:

(i) The dryer is a solvent recovery dryer which is operated in a manner such that the dryer remains closed and the solvent recovery phase continues until a final recovered solvent flow rate of 1.7 ounces per minute (fifty milliliters per minute) or less is attained.

(ii) The emission of VOC into the ambient air from the dryer does not exceed 3.5 pounds of VOC per one hundred pounds dry weight of articles cleaned, as determined under paragraph (L) of rule 3745-21-10 of the Administrative Code.

(b) Any solvent filter for petroleum solvent shall comply with one of the following:

(i) The solvent filter is a cartridge filter which is drained for at least eight hours in ~~its~~the filter's sealed housing before removal of any cartridge.

(ii) The filtration waste contains, before disposal and exposure to the ambient air, no more than 1.0 pound of VOC per one hundred pounds dry weight of articles cleaned, as determined under paragraph (M) of rule 3745-21-10 of the Administrative Code.

(c) Any bucket or barrel which contains petroleum solvent or petroleum solvent-laden waste shall be covered to minimize solvent evaporation.

(d) Any equipment associated with the use of petroleum solvent shall be visually inspected weekly to identify any liquid leaks of petroleum solvent.

(e) Any liquid or vapor leak of petroleum solvent shall be repaired within fifteen days after identifying the source of the leak, unless a necessary repair part

is not on hand. If a repair part is not on hand, ~~it~~ the repair part shall be ordered within three working days after identifying the source of the leak. ~~The leak shall be~~ and the leak repaired within fifteen days following the delivery of the necessary repair part.

- (2) Any owner or operator of a solvent recovery dryer subject to paragraph (BB)(1)(a) of this rule shall perform a test, in accordance with paragraph (N) of rule 3745-21-10 of the Administrative Code, to demonstrate the minimum length of time for operating the recovery cycle of the dryer.
- (3) Paragraphs (BB)(1)(a), (BB)(1)(b), and (BB)(2) of this rule ~~shall~~ do not apply to any petroleum dry cleaning facility that meets either of the following:
 - (a) The total manufacturer's rated capacity of all petroleum solvent dryers is less than or equal to eighty-three pounds of articles, dry basis.
 - (b) The total annual consumption of petroleum solvent is less than or equal to four thousand seven hundred gallons.
- (4) Recordkeeping.
 - (a) Any owner or operator of a petroleum solvent dry cleaning facility that is exempted pursuant to paragraph (BB)(3)(b) of this rule shall maintain records of annual solvent consumption in a readily accessible location for at least five years and ~~shall~~ make these records available to the director upon verbal or written request.
 - (b) Any owner or operator of a petroleum solvent dry cleaning facility shall maintain records of the following information in a readily accessible location for at least five years and ~~shall~~ make these records available to the director upon verbal or written request:
 - (i) Documentation of the results of any tests performed to determine compliance with the emission limitation specified in paragraph (BB)(1)(a)(ii) of this rule.
 - (ii) Documentation of the results of any tests performed to determine compliance with the limitation specified in paragraph (BB)(1)(b)(ii) of this rule.
 - (iii) The results of any measurements to determine compliance with the limitation specified in paragraph (BB)(1)(a)(i) of this rule.

(iv) The results of any leak checks, including, at a minimum, the following information:

(a) Date of inspection.

(b) Findings (may indicate no leaks discovered or location, nature, and severity of each leak).

(c) Leak determination method.

(d) Corrective action (date each leak repaired and reasons for any repair interval in excess of fifteen calendar days).

(e) Inspector's name and signature.

(5) Reporting.

(a) Any test result that shows an exceedance of the limitation specified in paragraph (BB)(1)(a)(i), (BB)(1)(a)(ii), or (BB)(1)(b)(ii) of this rule shall be reported to the director within thirty days after the occurrence.

(b) Any leaks in vapor or liquid lines that are not repaired within fifteen days after identification shall be reported to the director within thirty days after the repair is completed.

(c) For any petroleum dry cleaning facility that is exempted pursuant to paragraph (BB)(3)(b) of this rule and has an annual consumption of petroleum solvent greater than four thousand seven hundred gallons, the owner or operator shall so notify the director within thirty days of becoming aware of the occurrence.

(CC) No owner or operator of a continuous, polystyrene resin manufacturing process may cause, allow, or permit the discharge into the ambient air of any VOC from the material recovery section of the process after the date specified in paragraph (C)(37) of rule 3745-21-04 of the Administrative Code in excess of 0.12 pound of VOC per one thousand pounds of polystyrene resin produced.

(DD) Leaks from process units that produce organic chemicals.

(1) Except where exempted under paragraph (DD)(17) of this rule, each owner or operator of a process unit that produces as an intermediate or final product one or more of the organic chemicals identified in appendix A to this rule shall comply with paragraphs (DD)(2) to (DD)(6) of this rule no later than the date specified in paragraph (C)(38) of rule 3745-21-04 of the Administrative Code.

(2) Leak detection and repair program.

(a) A leak detection and repair program for equipment in the process unit shall be developed and implemented in accordance with paragraphs (DD)(2)(b) to (DD)(2)(m) of this rule.

(b) Except as otherwise provided in paragraphs (DD)(2)(c) and (DD)(2)(d) of this rule, equipment shall be monitored for leaks in accordance with the method specified in paragraph (F) of rule 3745-21-10 of the Administrative Code, as follows:

(i) ~~Any Monthly for any pump in light liquid service shall be monitored monthly.~~

(ii) ~~Any Monthly for any valve in gas/vapor service or in light liquid service shall be monitored monthly,~~ except that quarterly monitoring may be employed anytime after no leaks are detected during two consecutive months. ~~The quarterly monitoring shall begin beginning~~ with the next calendar quarter following the two consecutive months of no detected leaks and shall be conducted in the first month of each calendar quarter. The quarterly monitoring may continue until a leak is detected, at which time monthly monitoring shall be employed again.

(iii) Any of the following equipment shall be monitored within five calendar days after evidence of a leak or potential leak from the equipment by visual, audible, olfactory, or other detection method:

(a) Any pump in heavy liquid service.

(b) Any valve in heavy liquid service.

(c) Any pressure relief device in light liquid service or in heavy liquid service.

(d) Any flange or other connector.

(iv) Any equipment in which a leak is detected as described in paragraph (DD)(2)(g) of this rule shall be monitored within five working days after each attempt to repair, unless the owner or operator believes that the equipment was not successfully repaired.

- (c) For any valve in gas/vapor service or in light liquid service, an alternative monitoring schedule may be employed in lieu of the monitoring schedule specified in paragraph (DD)(2)(b)(ii) of this rule as follows:
- (i) The valve is designated as difficult to monitor and is monitored each calendar year, provided the following conditions are met:
 - (a) Construction of the process unit commenced prior to May 9, 1986.
 - (b) The owner or operator of the valve demonstrates that the valve cannot be monitored without elevating the monitoring personnel more than six feet above a support surface.
 - (c) The owner or operator of the valve has a written plan that requires monitoring of the valve at least once per year.
 - (ii) The valve is designated as unsafe to monitor and is monitored as frequently as practical during safe to monitor times, provided the following conditions are met:
 - (a) The owner or operator of the valve demonstrates that the valve is unsafe to monitor because monitoring personnel would be exposed to an immediate danger as a consequence of monitoring on a monthly basis.
 - (b) The owner or operator of the valve adheres to a written plan that requires monitoring of the valve as frequently as practical during safe to monitor times.
 - (iii) The valve is subject to an alternative monitoring schedule based on a skip period as specified in paragraph (DD)(12) of this rule.
- (d) Excluded from the monitoring requirements of paragraph (DD)(2)(b) of this rule are the following equipment:
- (i) Any pump that has no externally actuated shaft penetrating the pump housing and that is designated for no detectable emissions as provided in paragraph (DD)(7) of this rule.
 - (ii) Any pump that is equipped with a dual mechanical seal which has a barrier fluid system and sensor that comply with the requirements specified in paragraph (DD)(8) of this rule.

- (iii) Any pump that is equipped with a closed vent system capable of capturing and transporting any leakage from the pump seal to control equipment, provided the closed vent system and the control equipment comply with paragraphs (DD)(9) and (DD)(10) of this rule.
 - (iv) Any valve that has no externally actuated stem penetrating the valve and that is designated for no detectable emissions as provided in paragraph (DD)(7) of this rule.
 - (v) Any valve that is subject to the alternative monitoring standard for valves based on the percentage of valves leaking as provided in paragraph (DD)(13) of this rule.
- (e) Any pump in light liquid service shall be checked by visual inspection each calendar week for indications of liquids dripping from the pump seal, unless the pump is equipped with a closed vent system capable of transporting any leakage from the pump seal to control equipment, and the closed vent system and control equipment comply with paragraphs (DD)(9) and (DD)(10) of this rule.
- (f) Any sensor employed pursuant to paragraph (DD)(2)(d)(ii) or (DD)(3)(b) of this rule shall be checked daily, unless the sensor is equipped with an audible alarm.
- (g) A leak is detected when any of the following occurs:
- (i) A concentration of ten thousand ppmv or greater is measured from a potential leak interface of any equipment that is monitored for leaks using the method in paragraph (F) of rule 3745-21-10 of the Administrative Code.
 - (ii) There is an indication of liquids dripping from the seal of a pump in light liquid service.
 - (iii) A sensor employed pursuant to paragraph (DD)(2)(d)(ii) or (DD)(3)(b) of this rule indicates failure of the seal system, the barrier fluid system, or both.
- (h) When a leak is detected as described in paragraph (DD)(2)(g) of this rule, the following procedures shall be followed:

- (i) A weatherproof and readily visible identification tag, marked with the equipment identification number, is immediately attached to the leaking equipment.
 - (ii) A record of the leak and any attempt to repair the leak is entered into the leak repair log kept pursuant to paragraph (DD)(2)(k) of this rule.
 - (iii) The identification tag attached to the leaking equipment, other than a valve that is monitored pursuant to paragraph (DD)(2)(b)(ii) of this rule, may be removed after the leaking equipment is repaired.
 - (iv) The identification tag attached to a leaking valve that is monitored pursuant to paragraph (DD)(2)(b)(ii) of this rule may be removed after the leaking valve is repaired, monitored for leaks for two consecutive months as specified in paragraph (DD)(2)(b)(ii) of this rule, and found to have no detected leaks during those two consecutive months.
- (i) When a leak is detected as described in paragraph (DD)(2)(g) of this rule, the leaking equipment shall be repaired as soon as practicable, but no later than fifteen calendar days after the leak is detected, except for a delay of repair as provided in paragraph (DD)(11) of this rule. Leaking equipment shall be deemed repaired if the maximum concentration measured pursuant to paragraph (DD)(2)(b)(iv) of this rule is less than ten thousand ppmv.
- (j) When a leak is detected as described in paragraph (DD)(2)(g) of this rule, a first attempt at repair shall be made no later than five calendar days after the leak is detected; ~~and the first attempts at repair shall include~~ including, but ~~are~~ not limited to, the following best practices where practicable:
- (i) Tightening of bonnet bolts.
 - (ii) Replacement of bonnet bolts.
 - (iii) Tightening of packing gland nuts
 - (iv) Injection of lubricant into lubricated packing.
- (k) When a leak is detected as described in paragraph (DD)(2)(g) of this rule, the following information shall be recorded in a leak repair log:

- (i) The identification number of the leaking equipment and, for leaks based on monitoring, the identification numbers of the leak detection instrument and ~~its~~the operator.
- (ii) The basis for the detection of the leak; for example, monitoring, visual inspection, or sensor.
- (iii) The date on which the leak was detected and the date of each attempt to repair the leaking equipment.
- (iv) The methods of repair applied in each attempt to repair the leaking equipment.
- (v) One of the following entries within five working days after each attempt to repair the leaking equipment:
 - (a) "Not monitored," denoting the leaking equipment was presumed to still be leaking and it was not monitored.
 - (b) If the leaking equipment was monitored with a leak detection instrument, the maximum concentration that was measured as follows:
 - (i) The actual reading in ppmv.
 - (ii) "Below 10,000," denoting less than ten thousand ppmv.
 - (iii) "Above 10,000," denoting not less than ten thousand ppmv.
- (vi) If the leak is not repaired within fifteen calendar days after the date on which it was detected, the following:
 - (a) "Repair delayed" and the reason for the delay.
 - (b) If repair is being delayed until the next process unit shutdown due to technical infeasibility of repair, the signature of the owner or operator ~~whose decision it was~~who decided that the repair is technically infeasible without a process unit shutdown.
 - (c) The expected date of successful repair of the leak.

- (d) The dates of process unit shutdowns that occur while the leaking equipment is unrepaired.
 - (vii) The date on which the leak was successfully repaired.
- (l) The leak repair log shall be retained by the owner or operator of the process unit in a readily accessible location for a minimum of two years after the date on which the record was made.
- (m) Semiannual reports shall be submitted to the director by the first day of February and August and ~~shall~~ include the following information for the preceding semiannual periods:
 - (i) The process unit identification.
 - (ii) The number of pumps in light liquid service excluding those pumps designated for no detectable emissions under the provision of paragraph (DD)(2)(d)(i) of this rule and those pumps complying with paragraph (DD)(2)(d)(iii) of this rule.
 - (iii) The number of valves in gas/vapor service or in light liquid service excluding those valves designated for no detectable emission under paragraph (DD)(2)(d)(iv) of this rule and those valves subject to the alternative standard for monitoring under paragraph (DD)(2)(d)(v) of this rule.
 - (iv) The number of compressors excluding those compressors designated for no detectable emissions under paragraph (DD)(3)(c) of this rule and those compressors complying with paragraph (DD)(3)(d) or (DD)(3)(e) of this rule.
 - (v) For each month during the semiannual period, the following:
 - (a) The number of pumps in light liquid service for which leaks were detected as described in paragraph (DD)(2)(g) of this rule.
 - (b) The number of pumps in light liquid service for which leaks were not repaired within fifteen calendar days after the date of leak detection.
 - (c) The number of valves in gas/vapor service or in light liquid service for which leaks were detected as described in paragraph (DD)(2)(g) of this rule.

- (d) The number of valves in gas/vapor service or in light liquid service for which leaks were not repaired within fifteen calendar days after the date of leak detection.
 - (e) The number of compressors for which leaks were detected as described in paragraph (DD) of this rule.
 - (f) The number of compressors for which leaks were not repaired within fifteen calendar days after the date of leak detection.
 - (g) The facts that explain each delay of repair allowed pursuant to paragraph (DD)(11) of this rule.
- (vi) The dates of process unit shutdowns that occurred within the semiannual period.

(3) Compressors.

- (a) Except as otherwise provided in paragraphs (DD)(3)(c) to (DD)(3)(e) of this rule, any compressor in the process unit shall comply with paragraph (DD)(3)(b) of this rule.
- (b) The compressor shall be equipped with a seal that has a barrier fluid system and sensor which comply with paragraph (DD)(8) of this rule.
- (c) Excluded from paragraph (DD)(3)(b) of this rule is any compressor that is designated for no detectable emissions as provided in paragraph (DD)(7) of this rule.
- (d) Excluded from paragraph (DD)(3)(b) of this rule is any compressor that is equipped with a closed vent system capable of capturing and transporting any leakage from the compressor seal to control equipment, provided the closed vent system and the control equipment comply with paragraphs (DD)(9) and (DD)(10) of this rule.
- (e) Excluded from paragraph (DD)(3)(b) of this rule is any reciprocating compressor that meets the following conditions:
 - (i) The compressor was installed prior to May 9, 1986.
 - (ii) The owner or operator of the compressor demonstrates to the satisfaction of the director that recasting the compressor distance piece or replacing the compressor are the only options available to

bring the compressor into compliance with paragraph (DD)(3)(b) of this rule.

(4) Pressure relief devices in gas/vapor service.

- (a) Except as otherwise provided in paragraph (DD)(4)(e) of this rule, any pressure relief device in gas/vapor service in the process unit shall comply with paragraphs (DD)(4)(b) to (DD)(4)(d) of this rule.
- (b) Except during pressure releases, the pressure relief device shall be operated with no detectable emissions, as indicated by an instrument reading of less than five hundred ppmv above background, as measured by the method specified in paragraph (F) of rule 3745-21-10 of the Administrative Code.
- (c) No later than five calendar days after a pressure release, the pressure relief device shall be tested to confirm the condition of no detectable emissions in accordance with the method specified in paragraph (F) of rule 3745-21-10 of the Administrative Code.
- (d) After each pressure release, the pressure relief device shall be returned to a condition of no detectable emissions as soon as practicable, but no later than five calendar days after the pressure release, except for a delay of repair as provided in paragraph (DD)(11) of this rule.
- (e) Excluded from paragraphs (DD)(4)(b) to (DD)(4)(d) of this rule is any pressure relief device that is equipped with a closed vent system capable of capturing and transporting leakage through the pressure relief device to control equipment, provided the closed vent system and control equipment comply with paragraphs (DD)(9) and (DD)(10) of this rule.

(5) Sampling connection system.

- (a) Except as otherwise provided in paragraph (DD)(5)(c) of this rule, any sampling connection system in the process unit shall comply with paragraph (DD)(5)(b) of this rule.
- (b) The sampling connection system shall be equipped with a closed purge system or a closed vent system that meets one of the following:
 - (i) The purged process fluid is returned directly to the process line with zero VOC emissions to the ambient air.
 - (ii) The purged process fluid is collected and recycled with zero VOC emissions to the ambient air.

(iii) The closed purge system or closed vent system is designed and operated to capture and transport all the purged process fluid to control equipment that meets paragraph (DD)(10) of this rule.

(c) Excluded from paragraph (DD)(5)(b) of this rule is any sampling connection system that is an in-situ sampling system.

(6) Open-ended valves or lines.

(a) Any open-ended valve or line in the process unit shall be equipped with a cap, blind flange, plug, or second valve and shall comply with paragraphs (DD)(6)(b) to (DD)(6)(d) of this rule.

(b) Except during operations requiring the flow of process fluid through the open-ended valve or line, the cap, blind flange, plug, or second valve shall seal the open end of the open-ended valve or line.

(c) If equipped with a second valve, the open-ended valve or line shall be operated in a manner such that the valve on the process fluid end is closed before the second valve is closed.

(d) If a double block and bleed system is being used, the bleed valve or line may remain open during operations that require venting the line between the block valves, but shall comply with paragraph (DD)(6)(b) of this rule at all other times.

(7) Equipment designated for no detectable emissions.

(a) Any equipment (pump, valve, or compressor) designated for no detectable emissions pursuant to paragraph (DD)(2)(d)(i), (DD)(2)(d)(iv) or (DD)(3)(c) of this rule shall comply with paragraphs (DD)(7)(b) to (DD)(7)(d) of this rule.

(b) The equipment shall be operated with no detectable emissions as indicated by an instrument reading of less than five hundred ppmv above background as measured by paragraph (F) of rule 3745-21-10 of the Administrative Code.

(c) The equipment shall be tested for compliance with paragraph (DD)(7)(b) of this rule initially upon designation and annually.

(d) The designation of the equipment shall be signed by the owner or operator of the equipment in the log kept pursuant to paragraph (DD)(14)(b) of this rule.

(8) Barrier fluid systems and sensors for pumps and compressors.

- (a) When a pump or compressor is equipped with a seal that has a barrier fluid system and sensor which are employed to meet paragraph (DD)(2)(d)(ii) or (DD)(3)(a) of this rule, paragraphs (DD)(8)(b) to (DD)(8)(d) of this rule shall be met.
- (b) The barrier fluid system shall meet one of the following conditions:
 - (i) The barrier fluid system is operated with a barrier fluid at a pressure that is at all times greater than the stuffing box pressure of the pump or compressor.
 - (ii) The barrier fluid system is equipped with a barrier fluid degassing reservoir that is connected by a closed vent system to control equipment and the closed vent system and control equipment comply with paragraphs (DD)(9) and (DD)(10) of this rule.
 - (iii) The barrier fluid system is equipped with a system that purges the barrier fluid into a process stream with zero VOC emissions to the ambient air.
- (c) The barrier fluid system shall be in heavy liquid service or ~~shall~~ not be in VOC service.
- (d) The barrier fluid system shall be equipped with a sensor that will detect failure of the seal system, the barrier fluid system, or both based on criteria determined by the owner or operator from design considerations and operating experience.

(9) Closed vent systems.

- (a) Any closed vent system that is used to comply with paragraph (DD)(2)(d)(iii), (DD)(3)(d), (DD)(4)(e), or (DD)(8)(b)(ii) of this rule shall comply with paragraphs (DD)(9)(b) to (DD)(9)(d) of this rule.
- (b) The closed vent system shall be designed and operated with no detectable emissions, as indicated by an instrument reading of less than five hundred ppmv above background, as measured by the method specified in paragraph (F) of rule 3745-21-10 of the Administrative Code.
- (c) The closed vent system shall be tested for compliance with paragraph (DD)(9)(b) of this rule initially and annually.

- (d) The closed vent system shall be operated at all times when emissions may be vented to it.

(10) Control equipment.

- (a) Any control equipment that is used to comply with paragraph (DD)(2)(d)(iii), (DD)(3)(d), (DD)(4)(e), (DD)(5)(b)(iii), (DD)(8)(b)(ii), or (DD)(11)(d)(ii) of this rule shall comply with paragraphs (DD)(10)(b) to (DD)(10)(f) of this rule.
- (b) If the control equipment is a vapor recovery system, the vapor recovery system shall be designed and operated to recover VOC emissions vented to the vapor recovery system with an efficiency of at least ninety-five per cent by weight.
- (c) If the control equipment is an enclosed combustion device, the enclosed combustion device shall be designed and operated to reduce the VOC emissions vented to the enclosed combustion device with an efficiency of at least ninety-five per cent by weight, or to provide a minimum residence time of 0.75 second at a minimum temperature of fifteen hundred degrees Fahrenheit.
- (d) If the control equipment is a flare, the flare shall meet the following:
- (i) ~~The flare shall be designed~~ Designed for and operated with no visible emissions as determined by USEPA method 22, except for periods not to exceed a total of five minutes during any one hundred twenty consecutive minutes.
- (ii) ~~The flare shall be operated~~ Operated with either an electric arc ignition system or a pilot flame. If a pilot flame is employed, the flame shall be present at all times and ~~shall~~ be monitored with a thermocouple or any other equivalent device to detect the presence of the pilot flame. If an electric arc ignition system is employed, the arcing shall pulse continually and ~~shall~~ be monitored to detect any failure.
- (iii) ~~The flare shall be~~ Be steam-assisted, air-assisted or nonassisted.
- (iv) The net heating value of the gas being combusted in the flare, as determined by the method specified in paragraph (P)(2) of rule 3745-21-10 of the Administrative Code, shall be three hundred Btu/scf or greater if the flare is steam-assisted or air-assisted, or ~~shall be~~ two hundred Btu/scf or greater if the flare is nonassisted.

- (v) Except as provided in paragraph (DD)(10)(d)(vi) of this rule, ~~the flare shall~~ be designed and operated with an actual exit velocity, as determined by the method specified in paragraph (P)(3) of rule 3745-21-10 of the Administrative Code, less than sixty feet per second if the flare is steam-assisted or nonassisted, or less than the maximum permitted velocity, as determined in paragraph (P)(4) of rule 3745-21-10 of the Administrative Code, if the flare is air-assisted.
- (vi) Excluded from paragraph (DD)(10)(d)(v) of this rule is any steam-assisted or nonassisted flare that meets both of the following:
 - (a) The net heating value of the gas being combusted in the flare, as determined by the method specified in paragraph (P)(2) of rule 3745-21-10 of the Administrative Code, ~~shall be~~ greater than one thousand Btu/scf.
 - (b) The flare ~~shall be~~ designed and operated with an actual exit velocity, as determined by the method specified in paragraph (P)(3) of rule 3745-21-10 of the Administrative Code, less than four hundred feet per second.
- (e) The owner or operator of the control equipment shall monitor the control equipment to ensure ~~that it is operated~~operation and ~~maintained~~maintenance are in conformance with ~~its~~the design.
- (f) The control equipment shall be operated at all times when emissions may be vented to ~~it~~the control equipment.

(11) Delay of repair.

- (a) A delay of repair that is employed pursuant to paragraph (DD)(2)(i) or (DD)(4)(d) of this rule shall be allowed only as provided in paragraphs (DD)(11)(b) to (DD)(11)(f) of this rule.
- (b) ~~A delay of repair shall be allowed if~~If the repair is technically infeasible without a process unit shutdown. ~~However, the repair shall occur~~providing the repair occurs before the end of the next process unit shutdown.
- (c) ~~A delay of repair shall be allowed for~~For a piece of equipment that is isolated from the process and that does not remain in VOC service (for example, isolated from the process and properly purged).

- (d) ~~A delay of repair for~~ For a valve ~~shall be allowed~~ if the following occurs:
- (i) The owner or operator of the valve demonstrates that the emission of purged material resulting from immediate repair is greater than the emission likely to result from delay of repair.
 - (ii) When repair procedures are effected, the purged material is collected and destroyed or recovered in control equipment that meets paragraph (DD)(10) of this rule.
- (e) ~~A delay of repair for~~ For a pump ~~shall be allowed~~ if the following occurs:
- (i) The repair requires the use of a dual mechanical seal system and associated barrier fluid system.
 - (ii) The repair is completed as soon as practicable, but no later than six months after the leak was detected.
- (f) ~~A delay of repair beyond~~ Beyond a process unit shutdown ~~shall be allowed~~ for a valve ~~if~~ provided a valve assembly replacement is necessary during the process unit shutdown, valve assembly supplies have been depleted, and valve assembly supplies had been sufficiently stocked before the supplies were depleted. A delay of repair beyond the next process unit shutdown shall not be allowed for that valve unless the next process unit shutdown occurs sooner than six months after the first process unit shutdown.

(12) Alternative monitoring schedule for valves based on a skip period.

- (a) Any owner or operator of a process unit may elect to implement an alternative monitoring schedule in lieu of the monitoring requirements specified in paragraph (DD)(2)(b)(ii) of this rule, as provided in paragraph (DD)(2)(c)(iii) of this rule. The alternative monitoring schedule shall be based on skipping quarterly monitoring periods provided the percentage of valves leaking is no more than 2.0. Any owner or operator who elects to implement an alternative monitoring schedule shall comply with paragraphs (DD)(12)(b) to (DD)(12)(h) of this rule.
- (b) The owner or operator shall notify the director prior to implementing this alternative monitoring schedule. Such notification shall identify which valves will be subject to this alternative monitoring schedule and which work practice within paragraph (DD)(12)(e) of this rule will be implemented. Any valve in vacuum service, in heavy liquid service, or

not in VOC service, shall be excluded from this alternative monitoring schedule.

- (c) Any valve subject to this alternative monitoring schedule shall comply initially with the monitoring requirements specified in paragraph (DD)(2)(b)(ii) of this rule.
- (d) Any valve subject to this alternative monitoring schedule shall continue to be subject to paragraphs (DD)(2)(g) to (DD)(2)(m) of this rule.
- (e) One of the following two alternative work practices for skipping monitoring periods may be implemented:
 - (i) After two consecutive quarterly leak detection periods with the percentage of valves leaking equal to or less than 2.0, a monitoring program may begin in which the first quarter of every two consecutive quarterly leak detection periods is skipped.
 - (ii) After five consecutive quarterly leak detection periods with the percentage of valves leaking equal to or less than 2.0, a monitoring program may begin in which the first three quarters of every four consecutive quarterly periods is skipped.
- (f) If the percentage of valves leaking is greater than 2.0, the owner or operator shall comply with the monitoring requirements as specified in paragraph (DD)(2)(b)(ii) of this rule, but may again elect to use this alternative monitoring schedule.
- (g) The percentage of valves leaking shall be determined for the valves subject to this alternative monitoring schedule as the sum of the number of those valves found leaking during any portion of the current monitoring period and the number of those valves found leaking during a previous monitoring period for which repair has been delayed during the current monitoring period, divided by the total number of valves, and multiplied by one hundred.
- (h) The following information pertaining to valves subject to this alternative monitoring schedule shall be recorded in a log that is kept in a readily accessible location:
 - (i) A schedule of monitoring.
 - (ii) The percentage of valves leaking during each monitoring period.

- (13) Alternative monitoring standard for valves based on the allowable percentage of valves leaking.
- (a) Any owner or operator of a process unit may elect to implement an alternative monitoring standard based on maintaining the percentage of valves leaking at 2.0 or less in lieu of the monitoring requirements specified in paragraph (DD)(2)(b)(ii) of this rule, as provided in paragraph (DD)(2)(d)(v) of this rule. ~~The alternative monitoring standard shall be based on maintaining the percentage of valves leaking at 2.0 or less.~~ Any owner or operator who elects to implement an alternative monitoring standard shall comply with paragraphs (DD)(13)(b) to (DD)(13)(g) of this rule.
 - (b) The owner or operator shall notify the director prior to implementing this alternative monitoring standard.
 - (c) All valves in gas/vapor service or in light liquid service in the process unit shall be subject to this alternative monitoring standard, except for those valves which are designated as unsafe to monitor as provided in paragraph (DD)(2)(c)(ii) of this rule, those valves not in VOC service, and those valves in vacuum service.
 - (d) The percentage of valves leaking, as determined in accordance with paragraph (DD)(13)(f) of this rule, shall not exceed 2.0. If the percentage of valves leaking is greater than 2.0, the owner or operator shall comply with the monitoring requirements as specified in paragraph (DD)(2)(b)(ii) of this rule, but may again elect to use this alternative monitoring standard.
 - (e) All valves subject to this alternative monitoring standard shall be tested for compliance with paragraph (DD)(13)(d) of this rule initially upon implementation and annually.
 - (f) A compliance test shall be conducted in the following manner:
 - (i) ~~All~~ Monitor valves subject to this alternative monitoring standard ~~shall be monitored~~ for leaks within a one-week period by the method specified in paragraph (F) of rule 3745-21-10 of the Administrative Code.
 - (ii) If an instrument reading of ten thousand ppmv or greater is measured, a leak is detected.

(iii) ~~The~~ Determine the percentage of valves leaking shall be determined as the number of valves for which a leak is detected, divided by the number of valves monitored, and multiplied by one hundred.

(g) When a leak is detected as described in paragraph (DD)(13)(f)(ii) of this rule, the leaking valve shall be repaired in accordance with paragraphs (DD)(2)(h) and (DD)(2)(i) of this rule.

(14) Recordkeeping.

(a) Each owner or operator of a process unit as described in paragraph (DD)(1) of this rule shall comply with the recordkeeping requirements of paragraphs (DD)(14)(b) to (DD)(14)(g) of this rule. An owner or operator of more than one process unit may use one recordkeeping system to comply with the recordkeeping requirements, provided the system identifies each record by each process unit.

(b) The following information shall be recorded in a log that is kept in a readily accessible location:

(i) A list of identification numbers for equipment subject to paragraphs (DD)(2) to (DD)(10) of this rule.

(ii) A list of identification numbers for equipment designated for no detectable emissions as provided in paragraph (DD)(7) of this rule, and a signature of the owner or operator authorizing such designation.

(iii) A list of identification numbers for pressure relief devices subject to paragraph (DD)(4) of this rule.

(iv) A list of identification numbers for closed vent systems subject to paragraph (DD)(9) of this rule.

(v) For compliance tests required under paragraphs (DD)(4)(c), (DD)(7)(c), and (DD)(9)(c) of this rule, the following:

(a) The date of each compliance test.

(b) The background level measured during each compliance test.

(c) The maximum instrument reading measured at the equipment during each compliance test.

- (c) The following information pertaining to valves subject to an alternative monitoring schedule, as provided in paragraph (DD)(2)(c) of this rule, shall be recorded in a log that is kept in a readily accessible location:
 - (i) A list of identification numbers for valves designated as unsafe to monitor, an explanation for each valve stating why the valve is unsafe to monitor, and the plan for monitoring each valve.
 - (ii) A list of identification numbers for valves designated as difficult to monitor, an explanation for each valve stating why the valve is difficult to monitor, and the schedule for monitoring each valve.
 - (iii) A list of identification numbers for valves subject to the alternative monitoring schedule based on a skip period, a schedule for monitoring, and the percentage of valves leaking during each monitoring period.
- (d) The following information pertaining to closed vent systems and control equipment described in paragraphs (DD)(9) and (DD)(10) of this rule shall be recorded and kept in a readily accessible location:
 - (i) Detailed schematics, design specifications, and piping and instrumentation diagrams.
 - (ii) The dates and descriptions of any changes in the design specifications.
 - (iii) A description of the parameter or parameters monitored, as required in paragraph (DD)(10)(d) of this rule, to ensure that the control equipment is operated and maintained in conformance with its design, and an explanation of the reason for selecting such parameter or parameters.
 - (iv) Periods when the closed vent systems and control equipment are not operated as designed, including periods when a flare pilot light does not have a flame.
 - (v) Dates of startups and shutdowns of the closed vent systems and control equipment.
- (e) The following information pertaining to barrier fluid systems and sensors described in paragraph (DD)(8) of this rule shall be recorded in a log that is kept in a readily accessible location:

- (i) A list of identification numbers of pumps and compressors equipped with such barrier fluid systems and sensors.
 - (ii) The criteria that indicate failure of the seal system, the barrier fluid system, or both, as required in paragraph (DD)(8)(d) of this rule and an explanation of the criteria.
 - (iii) Any changes to such criteria and the reasons for the changes.
- (f) One of the following information for use in determining an exemption for the process unit as provided in paragraph (DD)(17)(a) of this rule shall be recorded in a log that is kept in a readily accessible location:
- (i) An analysis demonstrating the design capacity of the process unit.
 - (ii) A statement listing the feed and raw materials and products from the process unit and an analysis demonstrating whether these chemicals are heavy liquids or beverage alcohols.
 - (iii) An analysis demonstrating that no equipment is in VOC service.
- (g) The following information pertaining to specific equipment that are exempt as provided in paragraph (DD)(17)(b) of this rule shall be recorded in a log that is kept in a readily accessible location:
- (i) A list of identification numbers of equipment in vacuum service.
 - (ii) A list of identification numbers of equipment not in VOC service and the information or data used to demonstrate that the equipment is not in VOC service.
 - (iii) A list of equipment subject to an equivalent emission requirement that is approved by the director pursuant to paragraph (DD)(16) of this rule.

(15) Reporting.

- (a) Each owner or operator of a process unit as described in paragraph (DD)(1) of this rule shall comply with the reporting requirements specified in paragraphs (DD)(15)(b) to (DD)(15)(d) of this rule.
- (b) For compliance tests required under paragraphs (DD)(7)(c) and (DD)(9)(c) of this rule, paragraphs (A)(3) and (A)(4) of rule 3745-21-10 of the Administrative Code (pertaining to notification of intent to test) shall be

met. ~~The and the~~ results of such compliance tests ~~shall be~~ reported to the appropriate Ohio EPA district office or local air agency within thirty days after the test date.

- (c) The results of compliance tests required under paragraph (DD)(4)(c) of this rule shall be reported semiannually to the appropriate Ohio EPA district office or local air agency. ~~The semiannual reports shall be~~ and submitted by the first day of February and August and ~~shall~~ include information for the preceding semiannual period.
- (d) Any semiannual reports required under paragraph (DD)(2)(m) of this rule may be sent to the appropriate Ohio EPA district office or local air agency.

(16) Equivalent requirement.

- (a) Any owner or operator of a process unit may apply to the director for determination of an equivalent requirement in lieu of paragraphs (DD) (2) to (DD)(10) of this rule. The determination of equivalence will be evaluated by paragraphs (DD)(16)(b) to (DD)(16)(d) of this rule. If the director approves an equivalent requirement for a process unit, said requirement shall be specified in the special terms and conditions of an operating permit or variance issued by the director for the process unit.
- (b) The owner or operator applying for a determination of equivalency shall be responsible for collecting and verifying test data to demonstrate the proposed equivalence.
- (c) The equivalent requirement shall achieve a reduction in emissions of VOC at least equivalent to the reduction in emissions of VOC that would be achieved by compliance with the applicable requirements of paragraph (DD) of this rule.
- (d) The director may condition the approval of equivalence as necessary to ensure the same emission reduction as the applicable requirements of paragraph (DD) of this rule.

(17) Exemptions.

- (a) Exempted from paragraphs (DD)(2) to (DD)(6) of this rule are the following process units:
 - (i) Any process unit that has a design capacity to produce less than one thousand one hundred tons per year.

- (ii) Any process unit that produces only heavy liquid chemicals from heavy liquid feed or raw materials.
- (iii) Any process unit that produces beverage alcohol.
- (iv) Any process unit that has no equipment in VOC service as determined in accordance with paragraph (O)(2) of rule 3745-21-10 of the Administrative Code.
- (v) Any process unit at a petroleum refinery, as defined in paragraph (E)(15) of rule 3745-21-01 of the Administrative Code.

(b) Exempted from paragraphs (DD)(2) to (DD)(6) of this rule are the following equipment:

- (i) Any equipment not in VOC service, as determined in accordance with paragraph (O)(2) of rule 3745-21-10 of the Administrative Code.
- (ii) Any equipment in vacuum service.
- (iii) Any equipment subject to an equivalent emission limitation as provided in paragraph (DD)(16) of this rule.

(EE) Air oxidation processes that produce organic chemicals.

(1) Except where exempted under paragraph (EE)(2) of this rule, no owner or operator of an air oxidation process that produces an organic chemical identified in appendix A to this rule may cause, allow or permit the discharge into the ambient air of VOC from any process vent stream after the date specified in paragraph (C)(39) of rule 3745-21-04 of the Administrative Code unless the process vent stream is vented to a combustion device that is designed and operated to do either of the following:

- (a) To reduce the VOC emissions vented to ~~it~~ the combustion device with an efficiency of at least ninety-eight per cent by weight.
- (b) To emit VOC at a concentration less than twenty parts per million by volume, dry basis.

(2) Exemptions.

- (a) Any process vent stream which is vented to a combustion device for which construction commenced prior to May 9, 1986, ~~shall be~~ is exempt from paragraph (EE)(1) of this rule, provided the combustion device is

operated and maintained in accordance with design specifications and good engineering practices. This exemption ~~shall terminate~~ terminates for such process vent stream if the combustion device is replaced with new control equipment for which construction commenced on or after May 9, 1986.

- (b) Any process vent stream or combination of process vent streams which has a total resource effectiveness value greater than 1.0 ~~shall be~~ is exempt from paragraph (EE)(1) of this rule. If an air oxidation process has more than one process vent stream, the total resource effectiveness ~~shall be~~ is based upon a combination of the process vent streams.

(3) Total resource effectiveness value.

- (a) The total resource effectiveness value for an air oxidation process shall be calculated in accordance with the following equations:

- (i) For nonchlorinated process vent streams with a net heating value less than or equal to 3.6 and for all chlorinated process vent streams:

$$\text{TRE} = [a + bW^{0.88} + cW + dWH + eW^{0.88}H^{0.88} + fW^{0.5}] / E$$

where:

TRE = total resource effectiveness value.

E = maximum hourly VOC emission rate at the vent stream design flowrate (W), in kilograms of VOC per hour (kg/hr).

W = vent stream design flowrate at a standard temperature of twenty degrees Celsius, in standard cubic meters per minute (scm/min).

H = vent stream net heating value, as determined in accordance with paragraph (P)(2) of rule 3745-21-10 of the Administrative Code; in mega joules per standard cubic meter (10^6 J/scm); and a, b, c, d, e, and f = applicable coefficients from appendix B to this rule.

- (ii) For nonchlorinated process vent streams with a net heating value greater than 3.6:

$$\text{TRE} = [a + bW^{0.88} + cW + dWH + eW^{0.88}H^{0.88} + f(WH / 3.6)^{0.5}] / E$$

where TRE, E, W, H, a, b, c, d, e and f are defined as in paragraph (EE)(3)(a)(i) of this rule.

- (b) The parameters used in the total resource effectiveness equations shall be measured at the outlet of the final product recovery device where VOC is reclaimed for beneficial reuse (recycle, sale or use in another part of the process).
- (4) The exhaust gases from any combustion device installed to meet paragraph (EE)(1) of this rule for a process vent stream containing chlorinated VOC shall be controlled by a scrubber which is designed and operated to remove at least ninety-nine per cent, by weight, of the hydrogen chloride formed during combustion, unless the owner or operator of the air oxidation process demonstrates to the satisfaction of the director that a lesser control efficiency limitation is warranted based upon good engineering practices.
- (FF) "Steelcraft Manufacturing Company" (facility ID 1431050879) or any subsequent owner or operator of "Steelcraft Manufacturing Company" facility located at 9017 Blue Ash road, Cincinnati, Ohio ~~shall comply with~~ is subject to the following by no later than the dates specified in paragraph (C)(40) of rule 3745-21-04 of the Administrative Code:
- (1) The VOC content of the adhesive coatings employed in the adhesive coating line for steel door panels and in the adhesive coating line for honeycomb paper shall not exceed 0.7 pound of VOC per gallon of adhesive coating, excluding water and exempt solvents.
- (2) The uncontrolled VOC emissions from the steel door wipe cleaning operation shall be reduced and maintained below fourteen tons per year. The owner or operator shall keep monthly records, maintained at the facility for a period of three years, which document the quantity and composition of the solvents used in the door wiping operation. ~~These records shall be maintained at the facility for a period of three years.~~ The owner or operator shall notify the director within thirty days after occurrence of any annual VOC emission rate that exceeds fourteen tons per year. ~~A copy of the record showing the exceedance shall be submitted to the director within thirty days after the exceedance occurs.~~
- (GG) [Reserved.]
- (HH) [Reserved.]
- (II) [Reserved.]

(JJ) "OMNOVA Solutions Inc" (facility ID 1677010195) or any subsequent owner or operator of "OMNOVA Solutions Inc" facility located at 1380 Tech Way drive, Akron, Ohio ~~shall comply~~ is subject to the following, on and after May 25, 1988, ~~with the following:~~

(1) The VOC emissions from the nitrile-butadiene rubber production operation shall be controlled by employing a continuous steam stripper following the degassing vessels to maximize the removal of residual monomers (acrylonitrile and butadiene). The continuous steam stripper shall be designed and operated to achieve a residual monomer content, as determined by "Goodyear Method E-826," of not greater than nine hundred parts per million by weight (total acrylonitrile and butadiene) in the polymer (rubber) blend tanks immediately following the stripper, and all exhaust gases from the stripper shall be vented to the butadiene recovery operation or to a flare system which complies with paragraphs (DD)(10)(d), (DD)(10)(e), and (DD)(10)(f) of this rule. The owner or operator shall perform daily analyses of the residual monomer content in the polymer blend tanks and shall maintain records of the results of the analyses at the facility for a period of three years. An alternative method or procedure to that in "Goodyear Method E-826" may be used to demonstrate compliance with the above limitation provided that such method or procedure is in accordance with good engineering practice, authorized in writing by the director, and approved by the U.S. environmental protection agency as a revision to the state implementation plan. The owner or operator shall notify the director of any residual monomer content that exceeds nine hundred parts per million by weight. A copy of the record showing the exceedance shall be submitted to the director within forty-five days after the exceedance occurs.

(2) The VOC emissions from the butadiene recovery operation shall be vented to a flare system which complies with paragraphs (DD)(10)(d), (DD)(10)(e), and (DD)(10)(f) of this rule.

(KK) "PMC Cincinnati, Inc." (facility ID 1431380075) or any subsequent owner or operator of the "PMC Cincinnati, Inc." facility located at 2000 West street, Cincinnati, Ohio ~~shall comply~~, on and after May 25, 1988, with this subject to the following requirements for VOC emissions from the production of methyltin intermediates:

(1) Each process used for the production of methyltin intermediates shall be equipped with a VOC recovery system which is designed and operated to achieve a control efficiency of at least seventy per cent, by weight, as a weekly average for the seven-day period from Monday through Sunday, for the VOC emissions in the process vent gas, as determined under paragraph (C) of rule 3745-21-10 of the Administrative Code. The owner or operator shall on a daily basis determine the amount of VOC vented to the VOC vapor recovery system

from the processes and the amount of VOC recovered. The overall recovery efficiency shall be calculated each week as the ratio of the total recovered VOC for the seven-day period from Monday through Sunday to the total VOC vented to the VOC recovery system for the same seven-day period. The ratio shall be expressed as a percentage. The ratio shall be calculated not later than the Monday following each seven-day period, and the owner or operator shall maintain records of the calculations at the facility for a period of three years. The owner or operator shall notify the director of any weekly average control efficiency that is less than seventy per cent, by weight. A copy of the record showing the noncomplying weekly average control efficiency shall be submitted to the director within thirty days of the occurrence.

- (2) The railcar unloading operation shall be a closed-loop system that uses compressed VOC from storage, rather than nitrogen, to unload the VOC in the railcar.
- (LL) "The Lubrizol Corporation" (facility ID 0243000024) or any subsequent owner or operator of "The Lubrizol Corporation" facility located at 155 Freedom road, Painesville, Ohio ~~shall comply with~~ is subject to the following requirements for VOC emissions from reactor processes no later than the date specified in paragraph (C)(46) of rule 3745-21-04 of the Administrative Code:
- (1) Except where exempted under paragraph (LL)(3) of this rule, any reactor process vent stream shall be vented to one of the following control equipment:
 - (a) The control equipment is an enclosed combustion device that is designed and operated to do either of the following:
 - (i) Reduce the VOC emissions vented to it with an efficiency of at least ninety-eight per cent by weight or to emit VOC at a concentration not exceeding twenty parts per million by volume (dry basis), either of which is determined under paragraph (C) of rule 3745-21-10 of the Administrative Code.
 - (ii) Provide a minimum residence time of 0.75 second at a minimum temperature of sixteen hundred degrees Fahrenheit.
 - (b) The control equipment is a flare that meets paragraphs (DD)(10)(d), (DD)(10)(e), and (DD)(10)(f) of this rule.
 - (2) Any process wastewater stream from a reactor process shall be discharged to a wastewater separator that has all separator sections equipped with covers and seals which minimize the amount of VOC exposed to the ambient air.

(3) Exempted from paragraph (LL)(1) of this rule are the following reactor process vent streams:

- (a) The reactor process vent stream is not vented to an enclosed combustion device or flare and has a VOC emission rate less than five tons per year. If the reactor process has more than one of these reactor process vent streams, the VOC emission rate shall be based upon a combination of such reactor process vent streams. In such cases, the owner or operator shall calculate the calendar month and rolling twelve-month VOC emissions from the reactor process vent streams and maintain records of the results of the calculations at the facility for a period of three years. The owner or operator shall notify the director of any rolling twelve-month VOC emission calculation that exceeds five tons. A copy of the record showing the exceedance shall be submitted to the director within thirty days after the exceedance occurs.
- (b) The reactor process vent stream is vented to an enclosed combustion device or a flare for which construction commenced prior to May 25, 1988, provided the enclosed combustion device or flare is operated and maintained in accordance with design specifications. This exemption shall terminate for such reactor process vent stream if the enclosed combustion device or flare is replaced with new control equipment for which construction commenced on or after May 25, 1988.
- (c) The reactor process vent stream is an air bearing vent stream which has a VOC concentration between the lower explosive limit and the upper explosive limit and which has a total resource effectiveness value greater than 1.0, as determined under paragraph (EE)(3) of this rule. If the reactor process has more than one of these air bearing process vent streams, the total resource effectiveness value shall be based upon a combination of such reactor process vent streams.

(MM) "PPG Industries, Inc. - Cleveland" (facility ID 1318000101) or any subsequent owner or operator of the "PPG Industries, Inc. - Cleveland" facility located at 3800 West 143rd street, Cleveland, Ohio shall comply, on and after May 25, 1988, with the following requirements for the VOC emissions from the paint manufacturing operations and associated paint laboratory operations:

- (1) ~~The paint manufacturing operations shall include the following equipment for the processing or use of solvent based or waterbased paint materials: mixing tanks for paint liquids and pigments, grinding mills, paint thinning and tinting tanks, paint filling equipment for shipping containers, cleaning equipment for paint processing equipment, and recovery equipment for the cleaning solvents.~~

~~The paint laboratory operations shall include the following equipment for the processing or use of solvent based or waterbased paint materials: paint spray booths and associated ovens within the paint manufacturing quality control laboratory and the paint research laboratory.~~ The following equipment for processing or use of solvent-based or water-based paint materials shall be included:

- (a) For paint manufacturing operations: mixing tanks for paint liquids and pigments, grinding mills, paint thinning and tinting tanks, paint filling equipment for shipping containers, cleaning equipment for paint processing equipment, and recovery equipment for the cleaning solvents.
 - (b) For paint laboratory operations: paint spray booths and associated ovens within the paint manufacturing quality control laboratory and the paint research laboratory.
- (2) Except as otherwise provided in paragraph (MM)(4) of this rule, the VOC emissions from the equipment included within the paint manufacturing operations shall be vented either directly or by means of a building or local area exhaust to a control system which shall maintain compliance with any of the following:
- (a) A minimum control efficiency of 98.0 per cent by weight for the VOC emissions.
 - (b) A maximum outlet VOC concentration of twenty parts per million by volume (dry basis).
 - (c) A minimum incineration temperature of one thousand five hundred degrees Fahrenheit.
- (3) Except as otherwise provided in paragraph (MM)(4) of this rule, the VOC emissions from the equipment included within the paint laboratory operations shall be vented to a control system which shall maintain compliance with a minimum control efficiency of ninety per cent by weight for the VOC emissions or a maximum outlet VOC concentration of twenty parts per million by volume (dry basis).
- (4) Paragraphs (MM)(2) and (MM)(3) of this rule shall not apply to any specific piece of equipment included within the paint manufacturing operations or the paint laboratory operations during each of the following situations:
- (a) During any period in which there is no production activity or laboratory activity at said equipment.

- (b) During the processing or use of a waterbased paint material in said equipment, provided the following three conditions are met:
 - (i) The equipment is dedicated solely to the production of waterbased paint materials.
 - (ii) The VOC content of the waterbased paint material is less than or equal to 12.0 per cent VOC by weight, as determined under paragraph (B) of rule 3745-21-10 of the Administrative Code.
 - (iii) Any VOC emissions from the processing or use of the waterbased paint material that are not vented to the control systems specified in paragraphs (MM)(2) and (MM)(3) of this rule are included (accounted for) in a permit-to-install issued by the director after August 22, 1990 pursuant to Chapter 3745-31 of the Administrative Code.
- (5) The VOC control efficiency or outlet VOC concentrations shall be determined in accordance with paragraph (C) of rule 3745-21-10 of the Administrative Code.
- (6) For a control system identified in paragraph (MM)(2) or (MM)(3) of this rule that employs incineration, the incineration temperature shall be determined by means of a continuous measurement and recording of such temperature.
- (7) Any mixing or blending tank containing a paint material shall be equipped with a cover or lid that completely covers the opening of the tank, except for an opening no larger than necessary to allow for safe clearance for the mixer's shaft. Such tank shall be covered at all times in which the tank contains a paint material except when operator access is necessary to add ingredients or take samples.
- (8) For any specific piece of equipment included within the paint manufacturing operations or the paint laboratory operations, for which the owner or operator claims an exemption from paragraphs (MM)(2) and (MM)(3) of this rule, pursuant to paragraph (MM)(4) of this rule, the owner or operator shall keep daily records of the following information:
 - (a) The periods of time during which there is no production activity or laboratory activity.
 - (b) The VOC content of the waterbased paint material (in per cent VOC, by weight), and, if applicable, the application number for the permit to install which authorizes the use of the waterbased paint materials.

(9) The owner or operator shall maintain the records required by paragraphs (MM)(6) and (MM)(8) of this rule at the facility for a period of three years.

(NN) "Von Roll Isola USA, Inc." (facility ID 1318002663) or any subsequent owner or operator of the "Von Roll Isola USA, Inc." facility located at 4853 West 130th street, Cleveland, Ohio shall not cause, allow or permit the discharge into the ambient air of any VOC from any mica coating or laminating line after the date specified in paragraph (C)(48) of rule 3745-21-04 of the Administrative Code unless the following are met:

- (1) Except as provided in paragraph (NN)(2) of this rule, each mica coating or laminating line shall be equipped with a VOC emission control system that is designed and operated to achieve a capture efficiency of one hundred per cent and a control destruction efficiency of at least ninety-five per cent, by weight, for all the VOC emissions from the mica coating or laminating line. To meet the one hundred per cent capture efficiency requirement, each mica coating or laminating line shall employ a permanent total enclosure that complies with USEPA method 204 and paragraph (NN)(3) of this rule. For the VOC control device, the VOC control (destruction) efficiency shall be determined in accordance with paragraph (C) of rule 3745-21-10 of the Administrative Code.
- (2) Paragraph (NN)(1) of this rule shall not apply to any mica coating or laminating line which employs less than five tons of VOC per year. In such case, the owner or operator shall keep monthly records that document the VOC emissions from the mica coating or laminating line. These records shall be maintained at the facility for a period of three years. The owner or operator shall notify the director of any annual VOC emission rate that equals or exceeds five tons per year. A copy of the record showing the exceedance shall be submitted to the director within thirty days after the exceedance occurs.
- (3) Each permanent total enclosure shall be maintained under negative pressure at a minimum differential pressure of 0.007 inch of water, as a three-hour average, at all times when the mica coating or laminating line is in operation.
- (4) Monitoring devices and a recorder shall be employed to simultaneously and continuously measure and record the pressure inside and outside each permanent total enclosure. The monitoring and recording devices shall be calibrated, operated and maintained in accordance with the manufacturer's recommendations, with any modifications deemed necessary by the permittee.
- (5) The owner or operator shall submit quarterly, deviation (excursion) reports that identify all three-hour blocks of time during which each permanent total

enclosure was not maintained at the minimum pressure differential of 0.007 inch of water, as a three-hour average.

(OO) "AK Steel Corporation" (facility ID 1409010006) or any subsequent owner or operator of the "AK Steel Corporation" facility at 1801 Crawford street, Middletown, Ohio shall comply, on and after May 25, 1988, with the following VOC content limitations for the metal coil treatment operations, as determined under paragraph (B) of rule 3745-21-10 of the Administrative Code:

- (1) The VOC content of any rolling oil employed in the temper mills shall not exceed 6.9 pounds of VOC per gallon of oil, excluding water and exempt solvents.
- (2) The VOC content of any rust preventive oil employed in the temper mills, shears, corrective rewinds, slitters, coating lines, and the pickle lines shall not exceed 3.3 pounds of VOC per gallon of oil, excluding water and exempt solvents.
- (3) The VOC content of any anti-galling material employed in the aluminum coating operation shall not exceed 1.2 pounds of VOC per gallon of material, excluding water and exempt solvents.
- (4) The VOC content of any prelube oil employed at the facility shall not exceed 0.8 pound of VOC per gallon of oil, excluding water and exempt solvents.

(PP) "Formica Corporation - Evendale" (facility ID 1431150801) or any subsequent owner or operator of the "Formica Corporation - Evendale" facility located at 10155 Reading road, Cincinnati, Ohio shall comply, on and after May 25, 1988, with the either of the following requirements for the VOC emissions from each paper treater:

- (1) The VOC content of any coating employed in the paper treater shall not exceed 0.9 pound of VOC per gallon of coating, excluding water and exempt solvents, as determined under paragraph (B) of rule 3745-21-10 of the Administrative Code.
- (2) The paper treater shall be equipped with a capture system and control system which are designed and operated to achieve an overall control efficiency of at least eighty-five per cent by weight for the VOC emissions, as determined under paragraph (C) of rule 3745-21-10 of the Administrative Code.

(QQ) "Day-Glo Color Corp" (facility ID 1318006552) or any subsequent owner or operator of "Day-Glo Color Corp" facility located at 4515 St. Clair avenue, Cleveland, Ohio, shall comply with the following requirements by no later than the date specified in paragraph (C)(51) of rule 3745-21-04 of the Administrative Code:

- (1) The filtration process which separates the methanol from the solid dye shall be a vacuum system which consists of a vacuum pump and condenser.
 - (2) Each mixing vessel having a capacity of four hundred gallons or less shall be equipped with a lid that remains in place at all times unless the vessel is empty or being emptied. The lid shall maintain contact along the entire perimeter of the vessel's rim and shall have no openings except as follows:
 - (a) The opening for the mixer shaft shall be no larger than three inches in diameter.
 - (b) Any opening used for the addition of materials to the vessel shall be no more than one-fourth of the lid area in size and shall remain open only during the addition of materials.
- (RR) On and after March 12, 2006, "Sherwin-Williams Co." (facility ID 1318040267) or any subsequent owner or operator of the "Sherwin-Williams Co." facility located at 26300 Fargo avenue, Bedford Heights, Ohio shall comply with the following:
- (1) For the liquid mixing tanks, can liquid filling operations, gasser (gashouse) operations (can propellant filling operations and propellant line purging operations), can brushing operations (manual can cleaning operations), and can piercing operations at this facility, the total VOC emissions in any rolling twelve-month period shall not exceed 0.75 pound of VOC per one thousand aerosol cans produced.
 - (2) When a gashouse production line is in VOC operation, all VOC emissions from the gashouse production line, except during a safety diversion or emergency described under paragraph (RR)(8) of this rule, shall be vented to a thermal incinerator that is designed and operated with a destruction efficiency greater than or equal to ninety per cent by weight for VOC. A gashouse production line is in VOC operation when either the propellant being used to fill the aerosol cans contains VOC or the propellant being purged from the propellant line contains VOC. The VOC propellant being purged shall be recovered and stored in a fuel tank of the thermal incinerator.
 - (3) The average combustion temperature within the thermal incinerator, for any three-hour block of time when the gashouse is vented to the thermal incinerator, shall not be more than fifty degrees Fahrenheit below the average combustion temperature during the most recent emissions test of the thermal incinerator that demonstrated compliance with the VOC destruction efficiency specified in paragraph (RR)(2) of this rule.

(4) Monitoring and recordkeeping.

(a) Continuous monitoring devices.

(i) The owner or operator shall install, operate, and maintain a continuous temperature monitor and recorder that measures and records the combustion temperature within the thermal incinerator. The temperature monitor shall have a minimum accuracy of plus or minus one per cent of the temperature being monitored expressed in degrees Fahrenheit or plus or minus one degree Fahrenheit, whichever is greater. The temperature monitor and recorder shall be installed, calibrated, operated and maintained in accordance with the manufacturer's recommendations, with any modifications deemed necessary by the owner or operator.

(ii) The owner or operator shall install, operate, and maintain a lower explosive limit (LEL) monitoring system that continuously measures and records the concentration of VOC and percent LEL within each gashouse line and the inlet vent to the thermal incinerator. The LEL detectors shall have a minimum accuracy of plus or minus two per cent. The LEL detectors shall be installed, calibrated, operated and maintained in accordance with the manufacturer's recommendations. The owner or operator shall calibrate the LEL detectors once per month following the manufacturer's protocol and shall record the date and results of each calibration.

(iii) The owner or operator shall install, operate, and maintain mass flow meter that continuously measures and records the flow rate within each gashouse line. The mass flow meters shall have a minimum accuracy of plus or minus 1.5 per cent. The mass flow meters shall be installed, calibrated, operated and maintained in accordance with the manufacturer's recommendations. The owner or operator shall check the mass flow meters once every six months for accuracy using a pilot tube and shall record the date and results of each accuracy check.

(b) The owner or operator shall collect and record the following information for each day of gashouse operation:

(i) A log of operating time for each of the following: gashouse production line ventilation to the thermal incinerator, gashouse production line ventilation directly to ambient air, thermal incinerator operation,

temperature monitoring equipment operation, gashouse production line in VOC operation, and gashouse production line not in VOC operation.

- (ii) A log of all three-hour blocks of time during which the average combustion temperature within the thermal incinerator, when the gashouse was vented to the thermal incinerator, was more than fifty degrees Fahrenheit below the average combustion temperature during the most recent emissions test of the thermal incinerator that demonstrated compliance with the VOC destruction efficiency requirement specified in paragraph (RR)(2) of this rule.
 - (iii) A log of the dates and times of the bypass venting of gashouse emissions to ambient air and any downtime for the thermal incinerator and temperature monitoring equipment, when any gashouse production line is in VOC operation. Additional records on bypass venting due to safety diversions are specified under paragraph (RR)(4)(h) of this rule.
- (c) The owner or operator shall collect and record for each aerosol can production line at this facility the following production information each month:
- (i) Number of aerosol cans produced.
 - (ii) Name and amount (pounds) of each VOC liquid charged to the mixing tanks and filled into aerosol cans.
 - (iii) Number of aerosol cans filled with a VOC propellant by name of propellant, type of propellant filler (under-the-cup fill, needle fill, or Sepro fill), and type of emissions venting (vented to thermal incinerator or not vented to thermal incinerator).
 - (iv) Number of VOC propellant line purges by name of propellant, type of recovery (recovered for fuel tank of thermal incinerator or not recovered), and type of emissions venting (vented to thermal incinerator or not vented to thermal incinerator).
 - (v) Name and amount (pounds) of each VOC liquid (solvent) used in the manual aerosol can cleaning operation (can brushing operation).
 - (vi) Number of safety diversion events and number of emergency events, as described in paragraph (RR)(8)(a) of this rule.

- (d) The owner or operator shall collect and record the following chemical and physical properties for the VOC liquids and VOC propellants used in the aerosol can production lines of this facility:
- (i) For any VOC liquid used in liquid mixing and liquid filling of aerosol cans, the liquid name, the liquid density (pounds per gallon), and the vapor pressure (mmHg) at seventy degrees Fahrenheit and eighty degrees Fahrenheit.
 - (ii) For any VOC liquid used in manual aerosol can cleaning, the liquid name and the liquid density (pounds per gallon).
 - (iii) For any VOC propellant, the liquid density (pounds per gallon) under usual propellant storage temperature and pressure, the vapor density (pounds per cubic centimeter) at propellant filler temperature, the fraction VOC by weight, the molecular weight, and the lower explosive limit (LEL) concentration (ppmv).
- (e) The owner or operator shall calculate and record for each aerosol can production line at this facility the following information each month:
- (i) Monthly amount of VOC emissions (pounds) from the liquid mixing operations, as determined in accordance with paragraph (RR)(6)(a) of this rule.
 - (ii) Monthly amount of VOC emissions (pounds) from the can liquid filling operations, as determined in accordance with paragraph (RR)(6)(b) of this rule.
 - (iii) Monthly amount of VOC emissions (pounds) from the gashouse operations (propellant filling, propellant line purging, and safety diversions), as determined in accordance with paragraph (RR)(6)(c) of this rule.
 - (iv) Monthly amount of VOC emissions (pounds) from the manual aerosol can cleaning operations (can brushing operations), as determined in accordance with paragraph (RR)(6)(d) of this rule.
 - (v) Monthly amount of VOC emissions (pounds) from the aerosol can production line, which is the sum of data recorded under paragraphs (RR)(4)(e)(i) to (RR)(4)(e)(iv) of this rule.
- (f) The owner or operator shall collect and record for each can piercing operation at this facility the following information each month:

- (i) The monthly operation of aerosol cans pierced, categorized by type of product/propellant and size.
 - (ii) For each category of aerosol can identified under paragraph (RR)(4)(f)(i) of this rule, the name and amount (pounds per can) of VOC liquid (solvent) and VOC propellant contained within the aerosol can.
 - (iii) For each VOC liquid, the vapor pressure (mmHg) at eighty degrees Fahrenheit and the molecular weight (pounds per pound mole).
 - (iv) The monthly amount of VOC emissions (pounds) from can piercing operations, as determined in accordance with paragraph (RR)(6)(e) of this rule.
- (g) The owner or operator shall record for all aerosol can production lines and can piercing operations combined at this facility the following information each month:
- (i) The monthly amount of VOC emissions (pounds), which is a sum of the monthly VOC emissions recorded under paragraphs (RR)(4)(e)(v) and (RR)(4)(f)(iv) of this rule for each aerosol can production line and each can piercing operation, respectively.
 - (ii) The monthly number of aerosol cans produced, which is a sum of the monthly aerosol can production recorded under paragraph (RR)(4)(c)(i) of this rule for each aerosol can production line.
 - (iii) The amount of VOC emissions (pounds) during the rolling twelve-month period, which is the sum of the values recorded under paragraph (RR)(4)(g)(i) of this rule for this month and the previous eleven consecutive months.
 - (iv) The number of aerosol cans produced during the rolling twelve-month period, which is the sum of the values recorded under paragraph (RR)(4)(g)(ii) of this rule for this month and the previous eleven consecutive months.
 - (v) The VOC emissions rate during the rolling twelve-month period in pounds per one thousand cans, which is one thousand times the value from paragraph (RR)(4)(g)(iii) of this rule divided by the value from paragraph (RR)(4)(g)(iv) of this rule, and rounded to two decimal places.

- (h) The owner or operator shall collect and record for each aerosol can production line at this facility, the following information for each safety diversion event, as described in paragraph (RR)(8) of this rule:
 - (i) Twenty per cent LEL stamp, which indicates that a concentration between twenty per cent and forty per cent of the LEL occurred.
 - (ii) Date and time of the twenty per cent LEL stamp.
 - (iii) Event length (seconds).
 - (iv) Type of VOC propellant being employed in the gashouse.
 - (v) Average concentration of LEL detectors in gashouse line (ppmv).
 - (vi) Average flow rate (cfm).
 - (vii) Amount of VOC emissions (pounds).
- (i) The records required by paragraphs (RR)(4)(a) to (RR)(4)(h) of this rule shall be maintained for a minimum of five years and shall be available for review by the director or any authorized representative of the director during normal business hours.

(5) Reporting.

- (a) The owner or operator shall submit quarterly compliance status reports that include the following:
 - (i) Identify any emission rate violation in which the emission rate recorded under paragraph (RR)(4)(g)(v) of this rule exceeds the VOC emission limitation specified in paragraph (RR)(1) of this rule.
 - (ii) Identify any deviations from paragraphs (RR)(2) and (RR)(3) of this rule, as recorded under paragraphs (RR)(4)(b)(iii) and (RR)(4)(b)(ii) of this rule, respectively.
 - (iii) Provide summaries of the records specified under paragraphs (RR)(4)(a) to (RR)(4)(h) of this rule.
- (b) The owner or operator shall submit to the appropriate Ohio EPA district office or local air agency the quarterly compliance status reports specified in paragraph (RR)(5)(a) of this rule. These quarterly compliance status

reports shall be submitted by April thirtieth, July thirty-first, October thirty-first, and January thirty-first and shall cover the records for the previous calendar quarters.

(6) Determination of VOC emissions.

(a) VOC emissions from liquid mixing operations.

- (i) For liquid mixing operations, the monthly VOC emissions (pounds), E(mixing), shall be calculated as follows:

$$E(\text{mixing}) = E(\text{loading}) + (E)\text{venting}$$

where:

E(loading) = monthly VOC emissions from loading VOC liquids into mixing tanks

E(venting) = monthly VOC emissions from venting VOC liquids during mixing

- (ii) For loading VOC liquid into a mixing tank, the monthly VOC emissions shall be calculated, based on the ideal gas law and displacement of saturated vapors at seventy degrees Fahrenheit (twenty-one degrees Celsius), as follows:

E(loading) = monthly sum of $E_i(\text{loading})$ for all VOC liquid "i" loaded into mixing tanks

$$E_i(\text{loading}) = (P_i * X_i * V_i * MW_i) / (R * T)$$

where:

$E_i(\text{loading})$ = pounds of VOC emissions during the month from loading VOC liquid "i" into mixing tanks

P_i = vapor pressure of VOC liquid "i" at seventy degrees Fahrenheit, in mmHg

X_i = mole fraction of VOC liquid "i" in liquid mix (value of one is used for this emissions estimate)

V_i = volume of VOC liquid "i" charged to mixing tanks during the month in cubic feet (equals monthly gallons of liquid "i" divided by 7.48 gallons per cubic foot)

R = nine hundred ninety-nine mmHg-cubic feet per pound mole-degrees Kelvin

T = temperature in degrees Kelvin (equals two hundred seventy-three plus twenty-one degrees Celsius)

MW_i = molecular weight of VOC liquid "i", in pounds per pound mole

- (iii) For venting of VOC liquids during mixing, the monthly VOC emissions shall be calculated, based on the ideal gas law and venting of saturated vapors at eighty degrees Fahrenheit (twenty-seven degrees Celsius), as follows:

E(venting) = monthly sum of E_i(venting) for all VOC liquid "i" loaded into mixing tanks

$$E_i(\text{venting}) = (P_i * X_i * V_{i,v} * MW_i) / (R * T)$$

where:

E_i(venting) = pounds of VOC emissions during the month for venting a VOC liquid "i" during mixing

P_i = vapor pressure of VOC liquid "i" at eighty degrees Fahrenheit, in mmHg

X_i = mole fraction of VOC liquid "i" in liquid mix (a value of one is used for this emissions estimate)

V_{i,v} = volume (cubic feet) of saturated vapors removed by the ventilation system during mixing of VOC liquid "i" (equals monthly gallons of VOC liquid "i" times five times thirty divided by three hundred fifty based on five per cent of the total ventilation flow rate or five cubic feet per minute, an average mixing time of thirty minutes per batch, and a typical batch size of three hundred and fifty gallons)

R = nine hundred ninety-nine mmHg-cubic feet per pound mole-degrees Kelvin

T = temperature in degrees Kelvin (equals two hundred seventy-three plus twenty-seven degrees Celsius)

MW_i = molecular weight of VOC liquid "i", in pounds per pound mole

(iv) Alternative method.

An alternative method for calculating the monthly emissions rate for liquid mixing operations shall be as follows:

$$E(\text{mixing}) = EFM * V(\text{mixing})$$

where:

EFM = emission factor of 0.00131 pound VOC per pound VOC liquid throughput (this emission factor is based on the highest annual average emission factor for mixing operations during 1997 to 2000)

$V(\text{mixing})$ = monthly throughput of VOC liquid employed for mixing, in pounds

- (v) If for any month in which the use of the alternative method described in paragraph (RR)(6)(a)(iv) of this rule shows noncompliance with the VOC emission limit, the method described in paragraphs (RR)(6)(a)(i) to (RR)(6)(a)(iii) of this rule shall be used to calculate monthly emissions for liquid mixing operations. The compliance determination will then be based on these more detailed calculations.

(b) VOC emissions from liquid filling of aerosol cans.

- (i) For the liquid filling of aerosol cans, the monthly VOC emissions (pounds) shall be calculated, based on the ideal gas law and displacement of saturated vapors at seventy degrees Fahrenheit (twenty-one degrees Celsius) as follows:

$E(\text{filling})$ = monthly sum of $E_i(\text{filling})$ for all VOC liquid "i" filling of aerosol cans

$$E_i(\text{filling}) = (P_i * X_i * V_i * MW_i) / (R * T)$$

where:

$E_i(\text{filling})$ = pounds of VOC emissions during the month for VOC liquid "i" filling of aerosol cans

P_i = vapor pressure of VOC liquid "i" at seventy degrees Fahrenheit, in mmHg

X_i = mole fraction of VOC liquid "i" in liquid fill (a value of one is used for this emissions estimate)

V_i = volume of VOC liquid "i" filled into aerosol cans during the month in cubic feet (equals monthly gallons of VOC liquid "i" divided by 7.48 gallons per cubic foot)

R = nine hundred ninety-nine mmHg-cubic feet per pound mole-degrees Kelvin

T = temperature in degrees Kelvin (equals two hundred seventy-three plus twenty-one degrees Celsius)

MW_i = molecular weight of VOC liquid "i", in pounds per pound mole

(ii) Alternative method.

An alternative method for calculating the monthly emissions for liquid can filling operations shall be as follows:

$$E(\text{filling}) = \text{EFF} * V(\text{filling})$$

where:

EFF = emission factor of 0.00026 pound VOC per pound VOC liquid throughput (this emission factor is based on the highest annual average emission factor for liquid can filling operations during 1997 to 2000)

$V(\text{filling})$ = monthly throughput of VOC liquid employed for can filling, in pounds

- (iii) If for any month in which the use of the alternative method described in paragraph (RR)(6)(b)(ii) of this rule shows noncompliance with the VOC emission limit, the method described in paragraph (RR)(6)(b)(ii) of this rule shall be used to calculate monthly emissions for liquid filling of aerosol cans. The compliance determination will then be based on these more detailed calculations.

(c) VOC emissions from gasser (gashouse) operations.

- (i) For the gasser operations, the monthly VOC emissions in pounds), EG(total), shall be calculated as follows:

$$EG(\text{total}) = EG(\text{filling}) + EG(\text{purging}) + EG(\text{safety diversions})$$

where:

EG(fill) = monthly VOC emissions from filling aerosol cans with VOC propellant

EP(purging) = monthly VOC emissions from purging of lines containing VOC propellant

EG(safety diversions) = monthly VOC emissions from safety diversions of VOC control equipment

- (ii) For the filling of aerosol cans with VOC propellant and the purging of lines containing VOC propellant, the monthly VOC emissions for filling and line purging shall be calculated as follows:

$$EG(\text{filling}) = \text{monthly sum of } (NC_{p,f,v}) \times (EF_{p,f}) \times (K_p) \times (1 - CE_{p,v}/100) \times (VOC_p)$$

$$EP(\text{purging}) = \text{monthly sum of } (NP_{p,v}) \times (V_p) \times (LD_p) \times (1 - R_p) \times (1 - CE_{p,v}/100) \times (VOC_p)$$

where:

CE_{p,v} = control efficiency for propellant "p" VOC emissions and type of venting "v" for those emissions, based on venting of VOC propellant emissions to thermal incinerator or not and the overall control efficiency of the thermal incinerator for VOC

CE_{p,v} = zero per cent if propellant "p" VOC emissions are not vented to the thermal incinerator

CE_{p,v} = overall VOC control efficiency from most recent compliance test of the thermal incinerator, if propellant "p" VOC emissions are vented to the thermal incinerator

EF_{p,f} = emission factor for VOC propellant gas loss when filling cans with VOC propellant "p", based on propellant filler type "f" (under-the-cup fill, needle fill, or Sepro fill)

$EF_{p,f} = 0.2$ cubic centimeters per can for needle filling of VOC propellant "p"

$EF_{p,f} = 1.00$ cubic centimeters per can for Sepro filling of VOC propellant "p"

$EF_{p,f} = 1.75$ cubic centimeters per can for under-the-cup filling of VOC propellant "p"

K_p = conversion factor for gaseous VOC propellant "p" expressed in pounds per cubic centimeter at standard conditions

LD_p = liquid density of VOC propellant "p" at storage temperature and pressure, in pounds per gallon

$NC_{p,f,v}$ = number of cans produced with VOC propellant "p" and filling type "f" during the month by type of venting "v" (vented to thermal incinerator or not vented to thermal incinerator)

$NP_{p,v}$ = number of propellant line purges during the month for VOC propellant "p" by type of venting "v" (vented to thermal incinerator or not vented to thermal incinerator)

R_p = fraction by weight of purged VOC propellant "p" which is recovered and stored in a pressure tank

V_p = volume of propellant line purged for VOC propellant "p", in gallons

VOC_p = fraction VOC by weight for VOC propellant "p" (usually one for a VOC containing propellant)

(iii) Alternative method for filling and line purging.

For gasser operations equipped with a thermal incinerator in which the VOC emissions from the filling of aerosol cans with VOC propellant are vented to the thermal incinerator and the line purging of VOC propellant is recovered for use as a fuel in the thermal incinerator, the monthly VOC emissions for filling and line purging shall be calculated as follows:

$$EG(\text{filling}) + EG(\text{purging}) = EF * (NC/1000)$$

where:

EF = VOC emissions factor from most recent compliance test of the thermal incinerator, expressed in pounds VOC per thousand aerosol cans produced (based on the September 24, 2002 compliance test, EF equals 0.16 pound VOC per thousand aerosol cans)

NC = number of aerosol cans produced with VOC propellant during the month

- (iv) EG(safety diversions) is the sum of the VOC emissions for each safety diversion event during the month, as determined in accordance with paragraph (RR)(8) of this rule. The amount of VOC emissions in pounds for a safety diversion event EG(event) shall be calculated as follows:

$$EG(\text{event}) = C_{\text{avg}} * MW * \text{Flow} * \text{Time} * (4.256 \times 10^{-11})$$

where:

C_{avg} = average concentration of VOC propellant in gas stream being vented to ambient air during safety diversion event, in parts per million by volume

MW = molecular weight of VOC propellant being employed in gashouse at time of safety diversion event, in pounds per pound-mole

Flow = average flow rate of gas stream being vented to ambient air during safety diversion event, in cubic feet per minute

Time = length of safety diversion event, in seconds

4.256×10^{-11} = constant value based on various unit conversions and division by the Universal Gas Constant at standard conditions

- (d) VOC emissions from manual aerosol can cleaning operations.

For the manual aerosol can cleaning operations (can brushing operations), VOC emissions shall be equal to the mass of VOC solvent consumed in the operation. The monthly VOC emissions from can brushing shall be calculated as the sum of VOC emissions for all solvents consumed during that month. The VOC emissions from each VOC solvent consumed is calculated as the number of VOC solvent gallons consumed during the month times the VOC solvent density (pounds per gallon).

(e) VOC emissions from can piercing operations.

- (i) For the can piecing operations, monthly VOC emissions shall be the total VOC emissions from propellants plus the total VOC emissions from liquid recovery.
- (ii) The total VOC emissions (pounds) from propellants is the sum of the amount of VOC propellant within all cans pierced during that month. For a grouping of pierced cans by type and size, the monthly amount of VOC propellant is calculated as the amount of propellant VOC per can (pounds VOC per can), which is based on the type and size category, times the number of cans pierced during the month for that type and size category.
- (iii) The total VOC emissions (pounds) from liquid recovery for all cans pierced during a month is the sum of VOC emissions from the liquids (solvents) within all cans pierced during that month. The VOC emissions from the liquids shall be calculated, based on the ideal gas law and displacement of saturated vapors at eighty degrees Fahrenheit (twenty-seven degrees Celsius) for liquid flowing into a recovery drum or vessel, using the following formulas:

$E(\text{piercing}) = \text{sum of } E_i(\text{piercing}) \text{ for all VOC liquid "i" within the cans pierced in the month}$

$$E_i(\text{piercing}) = (P_i * X_i * V_i * MW_i) / (R * T)$$

$$V_i = W_i / (7.48 * D_i)$$

$W_i = \text{sum of } (W_{i,c} * N_c) \text{ for VOC liquid "i" for all cans pierced (by can type and size category "c") during the month}$

where:

$D_i = \text{density of VOC liquid "i", in pounds per gallon}$

$E(\text{piercing}) = \text{total VOC emissions from liquid recovery for all cans pierced in the month, in pounds}$

$E_i(\text{piercing}) = \text{pounds of VOC emissions from VOC liquid "i" recovered from cans pierced in the month}$

$MW_i = \text{molecular weight of VOC liquid "i", in pounds per pound mole}$

N_c = number of cans pierced during the month for can type and size category "c"

P_i = vapor pressure of VOC liquid "i" at eighty degrees Fahrenheit, in mmHg

R = nine hundred ninety-nine mmHg-cubic feet per pound mole-degrees Kelvin

T = temperature in degrees Kelvin (equals two hundred seventy-three plus twenty-seven degrees Celsius)

X_i = mole fraction of VOC liquid "i" in liquid of pierced cans (value of one is used for this emissions estimate)

V_i = volume of VOC liquid "i" within pierced cans for the month, in cubic feet

W_i = amount of VOC liquid "i" within the pierced cans for the month, in pounds

$W_{i,c}$ = amount of VOC liquid "i" for can type and size category "c", in pounds per can

7.48 = conversion factor in gallons per cubic foot

(7) VOC emissions testing.

The owner or operator shall conduct, or have conducted, emissions testing for the thermal incinerator to demonstrate the thermal incinerator's mass emission rate, destruction efficiency, and overall control efficiency for VOC emissions from this facility's gashouse operations in accordance with the following:

- (a) The emissions testing shall be conducted within six months of March 12, 2006, unless emissions testing had been conducted within three years prior to March 12, 2006 and the emissions testing demonstrated compliance with paragraph (RR)(2) of this rule.
- (b) For the emissions testing, the owner or operator shall meet the general provisions of paragraph (A) of rule 3745-21-10 of the Administrative Code.
- (c) The emissions testing shall be conducted in accordance with the test methods in paragraph (C) of rule 3745-21-10 of the Administrative Code with the

concentration of VOC in the thermal incinerator's inlet and outlet gas streams determined by means of USEPA method 25 or USEPA method 25A.

- (d) The emission testing to determine the VOC capture efficiency of the vapor collection system used to transport VOC emissions from the facility's gashouse operations (propellant filling of aerosol cans and propellant line purging) to the thermal incinerator shall be conducted by means of the test methods specified in paragraph (C)(3)(c) of rule 3745-21-10 of the Administrative Code.
 - (e) The emission testing shall be conducted while the facility's gashouse is operating at or near its maximum capacity, unless otherwise specified or approved by the appropriate Ohio EPA district office or local air agency.
 - (f) The overall control efficiency of the thermal incinerator for VOC shall be the destruction efficiency times the capture efficiency divided by one hundred.
 - (g) The mass emission rate of the thermal incinerator, expressed in pounds VOC per thousand aerosol cans produced, shall be the hourly mass emission rate (pounds VOC per hour) divided by the hourly production rate (one thousand cans per hour).
 - (h) Additional testing of the gashouse and the thermal incinerator may be required by the director to ensure continued compliance with the applicable requirements.
- (8) Safety diversion events and emergency events for gasser operations being vented to a thermal incinerator.
- (a) A safety diversion is the venting of gasser operations directly to ambient air, instead of being vented to the thermal incinerator, in order to meet requirements of NFPA 30B: "Code for the Manufacturing and Storage of Aerosol Products." A safety diversion occurs when any of the lower explosive limit (LEL) detectors in the gashouse detects a concentration between twenty per cent and forty per cent of the LEL. Under a safety diversion, as described in NFPA 30B, Section 5.4.2(E), the ventilation rate of the affected gashouse line is quickly increased, the gashouse line is vented immediately to ambient air (i.e. thermal incinerator is bypassed), and production activities usually continue. Safety diversion events are less than five minutes and shall be included in the determination of compliance with the monthly VOC emission limitation of 0.75 pound

VOC per thousand aerosol cans produced. A safety diversion event is not be a malfunction under paragraph (B) of rule 3745-15-06 of the Administrative Code.

- (b) An emergency event is a condition that shuts down the line, releases propellant in the gasser to atmosphere and vents the gashouse directly to ambient air, instead of being vented to the thermal incinerator as required by NFPA 30B, Section 5.12. Emergency events include safety diversions greater than five minutes, detected LEL concentrations greater than forty per cent, low flow alarms, power loss, fire alarms, explosion suppression systems discharge, gashouse and thermal oxidizer safety system monitoring device fault and emergency stops (E-Stops). An E-Stop occurs when a gashouse operator shuts down the line due to an observed safety issue caused by the gashouse operation such as employee injury, damage to equipment, or operation problems such as shredding of cans. The owner or operator shall maintain a record of the emergency events.
 - (c) The VOC emissions for a safety diversion event shall be calculated based on the average concentration of the LEL detectors associated with the gashouse line, the flow rate of the gashouse line (measured with a mass flow meter), the propellant being filled, and the length of the event (seconds).
 - (d) The owner or operator shall calibrate the LEL detectors once per month following the manufacturer's protocol and shall check the flow meters once every six months for accuracy using a pilot tube.
- (SS) On and after March 31, 1993, "Ritrama Duramark" (facility ID 1318007355) or any subsequent owner or operator of the "Ritrama Duramark" facility located at 341 Eddy road, Cleveland, Ohio shall not cause, allow or permit the discharge into the ambient air of any VOC from the vinyl film casting line unless all of the VOC emissions are vented to an incinerator that is designed and operated to achieve a control efficiency of at least ninety-eight per cent, by weight, as determined under paragraph (C) of rule 3745-21-10 of the Administrative Code.
- (TT) [Reserved.]
- (UU) "BP-Husky Refining LLC" (facility ID 0448020007) or any subsequent owner or operator of the "BP-Husky Refining LLC" facility located at 4001 Cedar Point road, Oregon, Ohio shall comply with the following requirements for VOC emissions:

- (1) On and after the date specified in paragraph (C)(55)(a) of rule 3745-21-04 of the Administrative Code, all VOC emissions from the SPOP waterwash tower spentwash flash drum and the POLY waterwash tower spentwash flash drum shall be vented to a flare that complies with paragraphs (DD)(10)(d) to (DD)(10)(f) of this rule.
 - (2) On and after the date specified in paragraph (C)(55)(b) of rule 3745-21-04 of the Administrative Code, all VOC emissions from the alkyl 1 blowdown drum and the alkyl 2 blowdown drum shall be vented to a flare that complies with paragraphs (DD)(10)(d) to (DD)(10)(f) of this rule.
 - (3) On and after the date specified in paragraph (C)(55)(b) of rule 3745-21-04 of the Administrative Code, all VOC emissions from the cokers 1 and 2 blowdown drum shall be vented to a flare that complies with paragraphs (DD)(10)(d) to (DD)(10)(f) of this rule.
 - (4) On and after the date specified in paragraph (C)(55)(c) of rule 3745-21-04 of the Administrative Code, all process wastewater from the crude desalter shall be discharged to a steam stripper for the recovery of condensable hydrocarbons, and all VOC emissions from the steam stripper shall be vented to a flare that complies with paragraphs (DD)(10)(d) to (DD)(10)(f) of this rule.
 - (5) On and after the date specified in paragraph (C)(55)(d) of rule 3745-21-04 of the Administrative Code, the barometric condensers and hot wells serving crude vacuum unit 1 and associated with cooling tower cell 6 shall be replaced with surface condensers (shell and tube heat exchangers).
 - (6) On and after the date specified in paragraph (C)(55)(e) of rule 3745-21-04 of the Administrative Code, the barometric condensers and hot wells serving crude vacuum unit 2 and associated with cooling tower cell 7 shall be replaced with surface condensers (shell and tube heat exchangers).
- (VV) "Marathon Petroleum Company LP - Canton Refinery" (facility ID 1576002006) or any subsequent owner or operator of the "Marathon Petroleum Company LP - Canton Refinery" facility located at 2408 Gambirinus road, S.W., Canton, Ohio shall comply with the following requirements for VOC emissions:
- (1) [Reserved].
 - (2) On and after March 31, 1993, all VOC emissions from the asphalt oxidizer shall be vented to an enclosed combustion device that is operated to reduce the VOC emissions by at least ninety-five per cent, by weight, as determined under paragraph (C) of rule 3745-21-10 of the Administrative Code.

(WW) [Reserved.]

(XX) [Reserved.]

(YY) "PMC Specialties Group" (facility ID 1431390137) or any subsequent owner or operator of the "PMC Specialties Group" facility located at 501 Murray road, Cincinnati, Ohio shall comply with the following requirements by no later than the dates specified in paragraph (C)(59) of rule 3745-21-04 of the Administrative Code:

- (1) Any VOC emissions from the reactor process vent streams from the methyl anthranilate and anthranilic acid manufacturing operations shall be vented to an enclosed combustion device that is designed and operated to reduce the VOC emissions by at least ninety-five per cent, by weight, as determined under paragraph (C) of rule 3745-21-10 of the Administrative Code.
- (2) For the OCBS fine chemicals system II process, the VOC emissions from the centrifuge vent shall not exceed twelve pounds of VOC per six thousand pounds of product, as determined under paragraph (C) of rule 3745-21-10 of the Administrative Code.

(ZZ) "Firestone Polymers" (facility ID 1677010000) or any subsequent owner or operator of the "Firestone Polymers" facility located at 381 West Wilbeth road, Akron, Ohio shall comply with the following requirements for the VOC emissions from the reactor processes no later than the date specified in paragraph (C)(60) of rule 3745-21-04 of the Administrative Code:

- (1) Except where exempted under paragraph (ZZ)(2) of this rule, each reactor process vent stream shall be vented to one of the following control equipment:
 - (a) An enclosed combustion device that is designed and operated to reduce the VOC emissions by at least ninety-eight per cent, by weight, as determined under paragraph (C) of rule 3745-21-10 of the Administrative Code.
 - (b) A flare that meets paragraphs (DD)(10)(d) to (DD)(10)(f) of this rule.
- (2) Exempted from paragraph (ZZ)(1) of this rule are the following reactor process vent streams:
 - (a) Any reactor process vent stream which is vented to an enclosed combustion device or a flare for which construction commenced prior to March 31, 1993, provided the enclosed combustion device or flare is operated and maintained in accordance with design specifications. This exemption shall terminate if the enclosed combustion device or flare is replaced with

new control equipment for which construction commenced on or after March 31, 1993.

- (b) Any reactor process vent stream which is an air-bearing vent stream, which has a VOC concentration between the lower explosive limit and the upper explosive limit, and which has a total resource effectiveness value greater than 1.0, as determined under paragraph (EE)(3) of this rule. If the reactor process has more than one of these air-bearing process vent streams, the total resource effectiveness value shall be based upon a combination of those air-bearing reactor process vent streams.

(AAA) [Reserved.]

(BBB) "Emerald Performance Materials, LLC" (facility ID 1677010029) or any subsequent owner or operator of the "Emerald Performance Materials, LLC" facility located at 240 West Emerling avenue, Akron, Ohio shall comply with the following requirements by no later than the date specified in paragraph (C)(62) of rule 3745-21-04 of the Administrative Code:

- (1) For the agerite resin D process, the VOC emissions from the recovery system vents and product neutralization and distillation system vents, except wash kettles (or still feed) condenser vents, stills vacuum jet tailpipe vents, and process emergency safety relief devices, shall be vented to a flare that meets paragraphs (DD)(10)(d) to (DD)(10)(f) of this rule.
- (2) For the superlite (trademark) process, the VOC emissions from the reactor process vent streams, except the process emergency safety relief devices, shall be vented to a control device that is designed and operated to achieve a control efficiency of at least ninety-five per cent, by weight, as determined under paragraph (C) of rule 3745-21-10 of the Administrative Code.
- (3) For the diphenylamine-based antioxidants process, the VOC emissions from the reactor process vent streams, except the emulsion recovery system tank vent, recovered MND tank vent, and process emergency safety relief devices, shall be vented to a control device that is designed and operated to achieve a control efficiency of at least ninety-five per cent, by weight, as determined under paragraph (C) of rule 3745-21-10 of the Administrative Code.
- (4) For the DPPD/PHDA process, the VOC emissions from the reactor process vent streams, except the north and south still jet vents and process emergency safety relief devices, shall be vented to a control device that is designed and operated to achieve a control efficiency of at least ninety-four per cent, by weight, as determined under paragraph (C) of rule 3745-21-10 of the Administrative Code.

(CCC) [Reserved.]

(DDD) Gasoline dispensing facilities (stage II vapor control systems).

- (1) Except where exempted under paragraph (DDD)(4) of this rule, no owner or operator of a gasoline dispensing facility may cause, allow, or permit the transfer of gasoline from a stationary storage tank at a gasoline dispensing facility into a motor vehicle after the dates specified in paragraph (C)(64) of rule 3745-21-04 of the Administrative Code unless the following requirements are met:
 - (a) All vapors displaced from the motor vehicle are vented to a vapor control system which is designed and operated to maintain an overall control efficiency of not less than ninety-five per cent, by weight, for the VOC in the displaced vapors and which is CARB certified. The vapor control system shall employ only coaxial hoses, and the use of remote check valves shall be prohibited.
 - (b) The vapor control system is installed, operated and maintained in accordance with the manufacturer's specifications and the applicable CARB certification, and is free of the following defects:
 - (i) Any component, that is required to be employed at all times pursuant to the system CARB certification, is absent or disconnected.
 - (ii) A vapor hose is crimped or flattened such that the vapor passage is blocked, or the pressure drop through the vapor hose exceeds by a factor of two or more the requirements in the CARB certification.
 - (iii) A nozzle boot is torn in one or more of the following manners:
 - (a) A triangular-shaped or similar tear one half inch or more to a side, or a hole one half inch or more in length.
 - (b) A slit one inch or more in length.
 - (iv) A faceplate or flexible cone is damaged in the following manner:
 - (a) For balance nozzles and for nozzles for aspirator and educator assist type systems, the capability to achieve a seal with a fill pipe interface is affected for one fourth of the circumference of the faceplate (accumulated).

- (b) For nozzles for vacuum assist-type systems, more than one fourth of the flexible cone is missing.
 - (v) Nozzle shutoff mechanisms are malfunctioning in any manner.
 - (vi) Vapor return lines, including such components as swivels, antirecirculation valves and underground piping are malfunctioning or are blocked, or restricted such that the pressure drop through the lines exceeds by a factor of two or more the requirements specified in the system CARB certification.
 - (vii) A vapor processing unit is inoperative or malfunctioning.
 - (viii) A vacuum producing device is inoperative or malfunctioning.
 - (ix) Pressure/vacuum relief valves, vapor check valves, or dry breaks are inoperative.
 - (x) Any vapor recovery equipment is leaking liquid gasoline or gasoline vapors.
 - (xi) Any other equipment defect identified in the CARB certification as one which substantially impairs the effectiveness of the vapor control system.
- (c) The vapor control system has successfully passed the testing requirements contained in paragraph (DDD)(2) of this rule.
- (d) Operating instructions for the vapor control system are conspicuously posted in each gasoline dispensing area. The operating instructions shall clearly describe how to properly fuel motor vehicles and shall specifically prohibit the topping off of the motor vehicle fuel tank.

(2) Testing:

- (a) Except as otherwise provided in paragraph (DDD)(2)(h) of this rule, within sixty days after the installation or modification of a vapor control system required pursuant to paragraph (DDD)(1) of this rule, the owner or operator of the gasoline dispensing facility shall perform and comply with the following tests:
 - (i) A leak test shall be performed in accordance with the test procedures contained in paragraph (Q) of rule 3745-21-10 of the Administrative Code to quantify the vapor tightness of the vapor

control system. The vapor control system shall comply with the leak rate criteria specified in the test procedures.

- (ii) A dynamic pressure performance test shall be performed in accordance with the test procedures contained in paragraph (R) of rule 3745-21-10 of the Administrative Code to determine the pressure drop through the vapor control system at prescribed flow rates. The vapor recovery system shall comply with the dynamic back pressures shown in the following table:

Nitrogen flowrate (standard cubic feet per hour)	Maximum dynamic back pressure (inches of water)
40	0.16
60	0.35
80	0.62

- (b) For purposes of paragraph (DDD)(2)(a) of this rule, the modification of a vapor control system shall include the following:
- (i) Any change, such as the removal of certified components and the addition or removal of piping or fittings, which may cause the vapor control system to be incapable of maintaining an overall control efficiency of not less than ninety-five per cent, by weight, for the VOC emissions.
- (ii) Any change which requires an installation permit pursuant to rule 3745-31-02 of the Administrative Code.
- (c) Not later than thirty days prior to any tests required pursuant to paragraphs (DDD)(2)(a) and (DDD)(2)(d) of this rule, the owner or operator of the gasoline dispensing facility shall submit a test notification to the appropriate Ohio EPA district office or local air agency. The test notification shall describe the proposed test methods and procedures, the time and date of the tests, and the person who will be conducting the tests. Failure to submit such notification prior to the tests may result in the Ohio EPA's refusal to accept the results of the tests. Personnel from the appropriate Ohio EPA district office or local air agency shall be permitted to witness the tests, examine the testing equipment, and acquire data and information during the tests. After completion of any tests, the owner or operator shall complete the post test inspection form

contained in appendix C to rule 3745-21-10 of the Administrative Code, and a comprehensive written report on the results of the tests shall be submitted to the appropriate Ohio EPA district office or local air agency within thirty days following the completion of the tests.

- (d) At intervals not to exceed five years, the owner or operator of the gasoline dispensing facility shall repeat and demonstrate compliance with the tests specified in paragraph (DDD)(2) of this rule.
- (e) The director may require the owner or operator of a gasoline dispensing facility to perform other tests that have been authorized by the USEPA if such tests are necessary to demonstrate the adequacy of a vapor control system.
- (f) The owner or operator of the gasoline dispensing facility shall perform and comply with any vapor control system tests specified in the applicable CARB certification. The tests shall be performed at the frequency specified in such certification.
- (g) Any vapor control system test conducted in accordance with the previous test procedures and specifications that were effective on March 31, 1993 and subsequently amended or deleted may be used, where appropriate, in lieu of the test procedures and specifications currently contained in this rule, provided such vapor control system test was not conducted after January 17, 1995.
- (h) Any vapor control system required by paragraph (DDD)(1) of this rule at an automobile or light-duty truck assembly plant that has not been tested in accordance with paragraph (DDD)(2)(a) of this rule as of January 17, 1995, shall be tested in accordance with paragraph (DDD)(2)(a) of this rule by July 17, 1995.

(3) Recordkeeping:

- (a) Any owner or operator of a gasoline dispensing facility which is subject to paragraph (DDD)(1) of this rule shall maintain the following records:
 - (i) The quantity of gasoline delivered to the facility during each calendar month.
 - (ii) The results of any tests performed pursuant to paragraph (DDD)(2) of this rule.

- (iii) A log of the date and description of all repair and maintenance work performed (including, but not limited to, work performed to meet manufacturer's specifications or CARB certification requirements), or any other modifications made to the vapor control system.
 - (iv) A copy of the most recent operating permit application (including emissions activity category form or appendix form) submitted to the Ohio EPA.
 - (v) A copy of the most recent operating permit issued by the Ohio EPA.
 - (vi) Proof of attendance and completion of the training required by the Ohio EPA for the operator or local manager of the gasoline dispensing facility.
 - (vii) Copies of all completed post test inspection forms.
- (b) All records shall be retained by the owner or operator for a period of not less than three years and shall be made available to the director or any authorized representative of the director for review during normal business hours.

(4) Exemptions:

- (a) Paragraph (DDD)(1) of this rule shall not apply to any gasoline dispensing facility which has a monthly gasoline throughput of less than ten thousand gallons per month or to any gasoline dispensing facility which is owned by an independent small business marketer and which has a monthly gasoline throughput of less than fifty thousand gallons per month. The monthly gasoline throughput shall be based upon the average monthly sales of gasoline during the period from November 16, 1990 through November 15, 1992; however, if a gasoline dispensing facility was inactive for any portion of this two year calculation period, the calculation period may be extended to include a total of twenty-four months of activity. This exemption shall cease to apply to a facility if during any calendar month after November 15, 1992, the gasoline throughput equals or exceeds ten thousand gallons or fifty thousand gallons, whichever is applicable. Furthermore, this exemption shall not apply to any facility which installed a vapor control system pursuant to paragraph (DDD)(1) of this rule and the monthly gasoline throughput subsequently falls below ten thousand gallons per month or, if owned by an independent small business marketer, fifty thousand gallons per month.

- (b) Paragraph (DDD)(1) of this rule shall not apply to marinas and aircraft refueling stands.
- (c) Paragraphs (DDD)(1)(a) and (DDD)(1)(b) of this rule that refer to a CARB certification shall not apply to any vapor control system at an automobile or light-duty truck assembly plant. In cases where it has been determined that the test procedures specified in paragraph (DDD)(2)(a)(i) or (DDD)(2)(a)(ii) of this rule are not appropriate for a vapor control system at an automobile or light-duty truck assembly plant, alternative test procedures may be employed and alternative testing deadlines may be established provided that written, prior approval has been obtained from the Ohio EPA.
- (d) Paragraph (DDD)(1) of this rule shall not apply to any motor vehicle fueling or refueling operation which is located at an automobile or light-duty truck assembly plant or heavier vehicle assembly facility and which, considered alone, has a monthly gasoline throughput of less than ten thousand gallons per month. Any gasoline dispensers located within two hundred feet from each other shall be considered as one operation for the purpose of this exemption.
- (e) Paragraph (DDD)(1) of this rule shall not apply to any gasoline dispensing pump that is used solely for the dispensing of E85, a gasoline with an ethanol content of fifty-one to eighty-three per cent by volume.
- (f) Paragraph (DDD)(1) of this rule shall not apply to any gasoline dispensing facility where gasoline is dispensed to a fleet of motor vehicles in which ninety-five per cent or more of the fleet of motor vehicles being fueled with gasoline is equipped with onboard refueling vapor recovery. If the gasoline dispensing facility is located at a motor vehicle assembly plant, the fleet of produced motor vehicles being initially fueled with gasoline shall be considered separate from any fleet of motor vehicles being refueled with gasoline. The owner or operator of a gasoline dispensing facility claiming this exemption shall maintain records documenting that at least ninety-five per cent of the fleet of motor vehicle being fueled with gasoline are equipped with onboard refueling vapor recovery. These records shall be retained by the owner or operator for a period of not less than five years and shall be made available to the director or any authorized representative of the director for review.

[Comment: This exemption is appropriate for gasoline dispensing facilities located at a facility or site serving a known fleet of motor vehicle rental agency, governmental agency, or motor vehicle assembly plant.]

(g) "New gasoline dispensing facility" exemption.

(i) For the purposes of this rule, a "new gasoline dispensing facility" is defined as one of the following:

(a) A facility that has not been operated as a gasoline dispensing facility at the location and after October 1, 2012, new underground storage tank systems and dispensers are installed that are compatible with onboard vapor recovery systems in vehicles.

(b) A gasoline dispensing facility which ~~loses its~~ exemption status has ceased under paragraph (DDD)(4)(a) of this rule, and does the following:

(i) Ensures that all existing dispensers, nozzles, hanging hardware, and piping above the shear valve are compatible with onboard vapor recovery systems in vehicles and replaces all existing hoses with low permeation hoses.

(ii) Conducts a leak test in accordance with the test procedures contained in paragraph (Q) of rule 3745-21-10 of the Administrative Code to quantify the vapor tightness of the system. The system shall comply with the leak rate criteria specified in the test procedures.

(iii) Submits a certification statement, signed by an authorized representative, to the appropriate Ohio EPA district office or local air agency that confirms that the gasoline dispensing facility has complied with paragraph (DDD)(4)(g)(i)(b) of this rule. The certification statement shall be submitted within thirty days after the leak test is conducted.

(ii) Paragraph (DDD)(1) of this rule shall not apply to a "new gasoline dispensing facility" if the facility does both of the following:

(a) Installs low permeation hoses by October 1, 2013 or within thirty days of starting operations, whichever occurs later.

(b) Notifies Ohio EPA in writing that owner or operator intends to comply with the provisions of paragraph (DDD)(4)(g) of this rule by May 29, 2013 or the commencement of construction.

(5) Suspension of control:

- (a) If, as a result of the development of a redesignation request prepared in accordance with requirements of the USEPA and Section 107(d)(3)(D) of the Clean Air Act contained in 42 USC 7407 (d)(3)(D), the director determines that the stage II vapor control program is not necessary in an area to ensure the maintenance of the ambient air quality standard for ozone and subsequently submits an official redesignation request to the USEPA for approval, the director may suspend the requirements of this paragraph in that area. This suspension shall remain in effect until a violation of the ambient air quality standard for ozone is measured in the area or the USEPA disapproves the redesignation request.
- (b) The director also may suspend the requirements of this paragraph in the event that the USEPA promulgates or a federal court of last resort requires the USEPA to promulgate onboard (on-the-vehicle) refueling control standards pursuant to Section 202(a)(6) of the Clean Air Act contained in 42 USC 7521(a)(6), unless the director determines that the stage II vapor control program is necessary for the attainment or maintenance of the ambient air quality standard for ozone and this determination is issued by the director as final findings and orders subject to public hearing requirements. If the director determines that the stage II vapor control program is not required for the maintenance of the ambient air quality standard for ozone after the promulgation of onboard control requirements, the director may suspend the requirements of this paragraph.
- (c) The director may extend the compliance date in paragraph (DDD)(4)(g) (ii) of this rule to install low permeation hoses, if the director determines that the equipment is not readily available or if the equipment does not adequately control permeation.
- (d) Beginning January 7, 2014, gasoline dispensing facilities equipped with stage II vapor control systems may start decommissioning the stage II vapor control systems in accordance with the following procedures:
 - (i) Not later than fourteen days prior to decommissioning the stage II vapor recovery system, notify Ohio EPA or the local air agency, in writing, that the gasoline dispensing facility intends to

decommission the stage II vapor recovery system and on what date the decommissioning will occur.

- (ii) Decommission the stage II vapor recovery system in accordance with the Petroleum Equipment Institute's guidance, "Recommended Practices for Installation and Testing of Vapor Recovery Systems at Vehicle Refueling Sites, ~~PEI/RP300-09~~PEI/RP300".
- (iii) Decommissioning shall be conducted in accordance with Petroleum Equipment Institute's guidance, "Recommended Practices for Installation and Testing of Vapor Recovery Systems at Vehicle Refueling Sites, ~~PEI/RP300-09~~PEI/RP300", by professional technicians who have received appropriate training, have all of the required tools, and possess applicable regulatory or equipment-manufacturer certifications, if such certifications are available.
- (iv) Prior to dispensing gasoline after the decommissioning has been completed, install low permeation hoses on all dispensers. Documentation of the use of low permeation hoses shall be retained for a period of not less than three years and shall be made available to the director or the director's authorized representative for review within seven business days of a request.
- (v) Within thirty days after the decommissioning has been completed, apply for a permit-by-rule or permit-to-install and operate for the stage I system in accordance with Chapter 3745-31 of the Administrative Code and submit a certification statement, signed by an authorized representative, to the appropriate Ohio EPA district office or local air agency that confirms that the gasoline dispensing facility has been decommissioned in accordance with petroleum equipment institute's guidance, "Recommended Practices for Installation and Testing of Vapor Recovery Systems at Vehicle Refueling Sites, ~~PEI/RP300-09~~PEI/RP300" and low permeation hoses have been installed on all dispensers.

[Comment: This rule specifies that, after decommissioning, a facility apply for either a permit-by-rule or permit-to-install and operate. In the event that Ohio EPA has not developed a permit-by-rule for decommissioned stage II facilities, the source owner or operator may apply for a permit-by-rule that conforms to the conditions of the appropriate permit-by-rule form consistent with the requirements of the rule. Ohio EPA will hold the applications in abeyance while the agency finalizes the amendments to rule

3745-31-03 of the Administrative Code to reflect the option of a decommissioned stage II facility.]

- (e) No later than January 1, 2017, all gasoline dispensing facilities equipped with stage II vapor control systems shall have decommissioned the stage II vapor control systems in accordance with the procedures outlined in paragraph (DDD)(5)(d) of this rule. The director may extend this deadline one year on an individual gasoline dispensing facility basis, if the gasoline dispensing facility can demonstrate that it is technically infeasible to comply with paragraph (DDD)(5)(d) of this rule or can demonstrate substantial economic hardship that prevents the decommissioning. The gasoline dispensing facility shall receive written authorization from the director in order to extend the decommissioning deadline.

(EEE) Portable oil and gas sources. Portable oil and gas sources relocating to Butler, Clermont, Cuyahoga, Geauga, Hamilton, Lake, Lorain, Medina, Portage, or Summit or Warren county may be subject to the USEPA CTG "Control Techniques Guidelines for the Oil and Natural Gas Industry". Sources subject to the requirements of this CTG shall submit an application for a federally enforceable installation permit in accordance with Chapter 3745-31 of the Administrative Code to incorporate applicable requirements of the CTG into a federally enforceable permit prior to relocation. The applicable requirements will be submitted to USEPA for incorporation into the Ohio state implementation plan.

Effective: 3/27/2022
Five Year Review (FYR) Dates: 11/29/2021 and 11/29/2026

CERTIFIED ELECTRONICALLY

Certification

03/17/2022

Date

Promulgated Under: 119.03
Statutory Authority: 3704.03(E)
Rule Amplifies: 3704.03(A), 3704.03(E)
Prior Effective Dates: 10/19/1979, 03/27/1981, 06/21/1982, 01/24/1983,
05/09/1986, 05/25/1988, 08/22/1990, 06/14/1991,
03/31/1993, 01/17/1995, 06/15/1999, 11/05/2002,
03/12/2006, 08/25/2008, 04/02/2009, 05/12/2011,
04/29/2013, 01/17/2014, 10/15/2015, 02/16/2019

Appendix A

**List of Organic Chemicals for which
Paragraphs (DD) and (EE) of
Rule 3745-21-09 of the Administrative Code are Applicable**

Organic Chemical

Acetal
Acetaldehyde
Acetaldol
Acetamide
Acetanilide
Acetic acid
Acetic Anhydride
Acetone
Acetone cyanohydrin
Acetonitrile
Acetophenone
Acetyl chloride
Acetylene
Acrolein
Acrylamide
Acrylic acid
Acrylonitrile
Adipic acid
Adiponitrile
Alkyl naphthalenes
Allyl alcohol
Allyl chloride
Aminobenzoic acid
Aminoethylethanolamine
p-aminophenol
Amyl acetates
Amyl alcohols
Amyl amine
Amyl chloride
Amyl mercaptans
Amyl phenol
Aniline
Aniline hydrochloride
Anisidine
Anisole
Anthranilic acid
Anthraquinone
Butyronitrile

Organic Chemical

Benzaldehyde
Benzamide
Benzene
Benzenedisulfonic acid
Benzenesulfonic acid
Benzil
Benzilic acid
Benzoic acid
Benzoin
Benzonitrile
Benzophenone
Benzotrichloride
Benzoyl chloride
Benzyl alcohol
Benzylamine
Benzyl benzoate
Benzyl chloride
Benzyl dichloride
Biphenyl
Bisphenol A
Bromobenzene
Bromonaphthalene
Butadiene
1-butene
n-butyl acetate
n-butyl acrylate
n-butyl alcohol
s-butyl alcohol
t-butyl alcohol
n-butylamine
s-butylamine
t-butylamine
p-tertbutyl benzoic acid
1,3-butylene glycol
n-butyraldehyde
Butyric acid
Butyric anhydride
Caprolactam

Carbon disulfide	Cyclohexene
Carbon tetrabromide	Cyclohexylamine
Carbon tetrachloride	Cyclooctadiene
Cellulose acetate	Decanol
Chloroacetic acid	Diacetone alcohol
m-chloroaniline	Diaminobenzoic acid
o-chloroaniline	Dichloroaniline
p-chloroaniline	m-dichlorobenzene
Chlorobenzaldehyde	o-dichlorobenzene
Chlorobenzene	p-dichlorobenzene
Chlorobenzoic acid	Dichlorodifluoromethane
Chlorobenzotrichloride	Dichloroethyl ether
Chlorobenzoyl chloride	1,2-dichloroethane (EDC)
Chlorodifluoromethane	Dichlorohydrin
Chlorodifluoroethane	Dichloropropene
Chloroform	Dicyclohexylamine
Chloronaphthalene	Diethylamine
o-chloronitrobenzene	Diethylene glycol
p-chloronitrobenzene	Diethylene glycol diethyl ether
Chlorophenols	Diethylene glycol dimethyl ether
Chloroprene	Diethylene glycol monobutyl ether
Chlorosulfonic acid	Diethylene glycol monobutyl ether acetate
m-chlorotoluene	Diethylene glycol monoethyl ether
o-chlorotoluene	Diethylene glycol monoethyl ether acetate
p-chlorotoluene	Diethylene glycol monomethyl ether
Chlorotrifluoromethane	Diethyl sulfate
m-cresol	Difluoroethane
o-cresol	Diisobutylene
p-cresol	Diisodecyl phthalate
Cresols (mixture)	Diisooctyl phthalate
Cresylic acid	Diketene
Crotonaldehyde	Dimethylamine
Crotonic acid	N,N-dimethylaniline
Cumene	N,N-dimethyl ether
Cumene hydroperoxide	N,N-dimethylformamide
Cyanoacetic acid	Dimethylhydrazine
Cyanogen chloride	Dimethyl sulfate
Cyanuric acid	Dimethyl sulfide
Cyanuric chloride	Dimethyl sulfoxide
Cyclohexane	Dimethyl terephthalate
Cyclohexanol	3,5-dinitrobenzoic acid
Cyclohexanone	Dinitrophenol
Dinitrotoluene	Diphenylamine
Dioxane	Diphenyl oxide
Dioxilane	Diphenyl thiourea

Dipropylene glycol	Formamide
Dodecene	Formic acid
Dodecylaniline	Fumaric acid
Dodecylphenol	Furfural
Epichlorohydrin	Glycerol
Ethanol	Glycerol dichlorohydrin
Ethanolamines	Glycerol triether
Ethyl acetate	Glycine
Ethyl acetoacetate	Glyoxal
Ethyl acrylate	Hexachlorobenzene
Ethylamine	Hexachloroethane
Ethylbenzene	Hexadecyl alcohol
Ethyl bromide	Hexamethylenediamine
Ethylcellulose	Hexamethylene glycol
Ethyl chloride	Hexamethylenetetramine
Ethyl chloroacetate	Hydrogen cyanide
Ethylcyanoacetate	Hydroquinone
Ethylene	p-hydroxybenzoic acid
Ethylene carbonate	Isoamylene
Ethylene chlorohydrin	Isobutanol
Ethylenediamine	Isobutyl acetate
Ethylene dibromide	Isobutylene
Ethylene glycol	Isobutyraldehyde
Ethylene glycol diacetate	Isobutyric acid
Ethylene glycol dimethyl ether	Isodecanol
Ethylene glycol monobutyl ether	Isoctyl alcohol
Ethylene glycol monobutyl ether acetate	Isopentane
Ethylene glycol monoethyl ether	Isophorone
Ethylene glycol monoethyl ether acetate	Isophthalic acid
Ethylene glycol monomethyl ether	Isoprene
Ethylene glycol monomethyl ether acetate	Isopropanol
Ethylene glycol monophenyl ether	Isopropyl acetate
Ethylene glycol monopropyl ether	Isopropylamine
Ethylene oxide	Isopropyl chloride
Ethyl ether	Isopropylphenol
2-ethylhexanol	Ketene
Ethyl orthoformate	Linear alkyl sulfonate
Ethyl oxalate	Linear alkylbenzene (linear dodecylbenzene)
Ethyl sodium oxalacetate	Maleic acid
Formaldehyde	Maleic anhydride
Malic acid	Methanol
Mesityl oxide	Methyl acetate
Metanilic acid	Methyl acetoacetate
Methacrylic acid	Methylamine
Methallyl chloride	n-methylaniline

Methyl bromide	n-pentane
Methyl butynol	1-pentene
Methyl chloride	Perchloroethylene
Methylcyclohexane	Perchloromethyl mercaptan
Methylcyclohexanone	o-phenetidine
Methylene chloride	p-phenetidine
Methylene dianiline	Phenol
Methylene diphenyl diisocyanate	Phenolsulfonic acids
Methyl ethyl ketone	Phenyl anthranilic acid
Methyl formate	Phenylenediamine
Methyl isobutyl carbinol	Phosgene
Methyl isobutyl ketone	Phthalic anhydride
Methyl methacrylate	Phthalimide
Methylpentynol	b-picoline
a-methylstyrene	Piperazine
Methyl tert-butyl ether	Polybutenes
Morpholine	Polyethylene
a-naphthalene sulfonic acid	Polyethylene glycol
b-naphthalene sulfonic acid	Polypropylene
a-naphthol	Polypropylene glycol
b-naphthol	Polystyrene
Neopentanoic acid	Propionaldehyde
o-nitroaniline	Propionic acid
p-nitroaniline	n-propyl alcohol
o-nitroanisole	Propylamine
p-nitroanisole	Propyl chloride
Nitrobenzene	Propylene
Nitrobenzoic acid (o, m, and p)	Propylene chlorohydrin
Nitroethane	Propylene dichloride
Nitromethane	Propylene glycol
2-nitrophenol	Propylene oxide
Nitropropane	Pyridine
Nitrotoluene	Quinone
Nonene	Resorcinol
Nonylphenol	Resorcylic acid
Octylphenol	Salicylic acid
Paraldehyde	Sodium acetate
Pentaerythritol	Sodium benzoate
Sodium carboxymethyl cellulose	Succinonitrile
Sodium chloroacetate	Sulfanilic acid
Sodium formate	Sulfolane
Sodium phenate	Tannic acid
Sorbic acid	Terephthalic acid
Styrene	Tetrachloroethanes
Succinic acid	Tetrachlorophthalic anhydride

Tetraethyl lead
Tetrahydronaphthalene
Tetrahydrophthalic anhydride
Tetramethyl lead
Tetramethylenediamine
Tetramethylethylenediamine
Toluene
Toluene-2,4-diamine
Toluene-2,4-diisocyanate
Toluene diisocyanates (mixture)
Toluenesulfonamide
Toluenesulfonic acids
Toluenesulfonyl chloride
Toluidines
Trichlorobenzenes
1,1,1-trichloroethane
1,1,2-trichloroethane
Trichloroethylene
Trichlorofluoromethane
1,2,3-trichloropropane
1,1,2-trichloro-1,2,2-trifluoroethane
Triethylamine
Triethylene glycol
Triethylene glycol dimethyl ether
Triisobutylene
Trimethylamine
Urea
Urea-formaldehyde
Vinyl acetate
Vinyl chloride
Vinylidene chloride
Vinyl toluene
o-xylene
p-xylene
Xylenes (mixture)
Xylenol
Xylidine

3745-21-09, Appendix B

1

Appendix B**Coefficients for the Total Resource Effectiveness Equations**

FOR CHLORINATED PROCESS VENT STREAMS, IF $0 \leq$ NET HEATING VALUE (MJ/scm)
 ≤ 3.5 :

W = Vent Stream Flowrate (scm/min)	a	b	c	d	e	f
W < 13.5	48.73	0	0.404	-0.1632	0	0
13.5 < W ≤ 700	42.35	0.624	0.404	-0.1632	0	0.0245
700 < W ≤ 1400	84.38	0.678	0.404	-0.1632	0	0.0346
1400 < W ≤ 2100	126.41	0.712	0.404	-0.1632	0	0.0424
2100 < W ≤ 2800	168.44	0.747	0.404	-0.1632	0	0.0490
2800 < W ≤ 3500	210.47	0.758	0.404	-0.1632	0	0.0548

FOR CHLORINATED PROCESS VENT STREAMS, IF $3.5 <$ NET HEATING VALUE
(MJ/scm) :

W = Vent Stream Flowrate (scm/min)	a	b	c	d	e	f
W < 13.5	47.76	0	-0.292	0	0	0
13.5 < W ≤ 700	41.58	0.605	-0.292	0	0	0.0245
700 < W ≤ 1400	82.84	0.658	-0.292	0	0	0.0346
1400 < W ≤ 2100	123.10	0.691	-0.292	0	0	0.0424
2100 < W ≤ 2800	165.36	0.715	-0.292	0	0	0.0490
2800 < W ≤ 3500	206.62	0.734	-0.292	0	0	0.0548

FOR NONCHLORINATED PROCESS VENT STREAMS, IF $0 \leq$ NET HEATING VALUE
(MJ/scm) ≤ 0.48 :

W = Vent Stream Flowrate (scm/min)	a	b	c	d	e	f
W < 13.5	19.05	0	0.113	-0.214	0	0
13.5 < W ≤ 1350	16.61	0.239	0.113	-0.214	0	0.0245
1350 < W ≤ 2700	32.91	0.260	0.113	-0.214	0	0.0346
2700 < W ≤ 4050	49.21	0.273	0.113	-0.214	0	0.0424

FOR NONCHLORINATED PROCESS VENT STREAMS, IF $0.48 < \text{NET HEATING VALUE (MJ/scm)} \leq 1.9$:

W = Vent Stream Flowrate (scm/min)	a	b	c	d	e	f
W < 13.5	19.74	0	0.400	-0.202	0	0
13.5 < W ≤ 1350	18.30	0.138	0.400	-0.202	0	0.0245
1350 < W ≤ 2700	36.28	0.150	0.400	-0.202	0	0.0346
2700 < W ≤ 4050	54.26	0.158	0.400	-0.202	0	0.0424

FOR NONCHLORINATED PROCESS VENT STREAMS, IF $1.9 < \text{NET HEATING VALUE (MJ/scm)} \leq 3.6$:

W = Vent Stream Flowrate (scm/min)	a	b	c	d	e	f
W < 13.5	15.24	0	0.033	0	0	0
13.5 < W ≤ 1190	13.63	0.157	0.033	0	0	0.0245
1190 < W ≤ 2380	26.95	0.171	0.033	0	0	0.0346
2380 < W ≤ 3570	40.27	0.179	0.033	0	0	0.0424

FOR NONCHLORINATED PROCESS VENT STREAMS, IF $3.6 < \text{NET HEATING VALUE (MJ/scm)}$:

W' = Vent Stream Flowrate (scm/min) HT/3.6	a	b	c	d	e	f
W' < 13.5	15.24	0	0	0.0090	0	0
13.5 < W' ≤ 1190	13.63	0	0	0.0090	0.0503	0.0245
1190 < W' ≤ 2380	26.95	0	0	0.0090	0.0546	0.0346
2380 < W' ≤ 3570	40.27	0	0	0.0090	0.0573	0.0424

3745-21-10

Compliance test methods and procedures.

[Comment: For dates and availability of non-regulatory government publications, publications of recognized organizations and associations, federal rules, and federal statutory provisions referenced in this rule, see paragraph (JJ) of rule 3745-21-01 of the Administrative Code titled "referenced materials."]

(A) General provisions.

- (1) The methods and procedures of this rule apply to sources governed by rule 3745-21-09 of the Administrative Code.
- (2) Use of an alternative test method, in lieu of one of the USEPA's approved test methods or in lieu of other methods specified in this rule, shall be approved by the USEPA as a revision of the state implementation plan.
- (3) The results of any compliance testing required by the director for tests conducted pursuant to paragraphs (C) to (F) and (L) of this rule shall not be accepted unless the Ohio EPA district office or local air agency has been notified of the intent to test in accordance with paragraph (A)(4) of this rule not less than thirty days before the proposed initiation of the testing.
- (4) Any person notifying the Ohio EPA district office or local air agency of a proposed emissions compliance test shall include as part of the notification the following information:
 - (a) A statement indicating the purpose of the proposed test and the applicable paragraph of rule 3745-21-09 of the Administrative Code.
 - (b) A detailed description of the facility to be tested.
 - (c) A detailed description of the test procedures, equipment and sampling sites.
 - (d) A timetable, setting forth the dates on which the following will occur:
 - (i) The testing will be conducted.
 - (ii) The final test report will be submitted (not later than thirty days after completion of on-site sampling).
- (5) For any source compliance determination, the owner or operator of the source shall be responsible for providing the following:
 - (a) Sampling ports, pipes, lines, or appurtenances for the collection of samples and data required by the test procedures.

(b) Safe access to the sample and data collection locations.

(c) Light, electricity, and other utilities required for sample and data collection.

(B) Method for the determination of volatile organic compound content, solids content, and density of surface coatings and inks.

(1) This method applies to coatings, inks or other coating materials employed in a coating line, printing line or other operation. For purposes of this method "coating" shall also mean "ink" or other coating material.

(2) Any determination of VOC content, solids content, or density of a coating shall be based on the coating as employed (as applied), including the addition of any thinner or viscosity reducer to the coating.

(3) When a sample of a coating is obtained for analysis by any of the procedures described in this method, the amount of the sample shall be at least one quart. The sample shall be placed in an air-tight container. When multiple package coatings are sampled, separate samples of each component shall be obtained.

(4) Using either the procedures set forth in USEPA method 24 (for coatings), USEPA method 24A (for flexographic and rotogravure printing inks and related coatings) and 40 CFR Part 63, Subpart PPPP, Appendix A (for reactive adhesives), or the coating formulation data from the coating manufacturer and coating user, the following shall be determined, where appropriate:

D_C = density of coating, in pounds of coating per gallon of coating.

D_{VM} = density of volatile matter in coating, in pounds of volatile matter per gallon of volatile matter.

V_S = volume fraction of solids (nonvolatile matter) in coating, in gallon of solids per gallon of coating.

V_{VM} = volume fraction of volatile matter in coating, in gallon of volatile matter per gallon of coating.

V_W = volume fraction of water in coating, in gallon of water per gallon of coating.

W_S = weight fraction of solids (nonvolatile matter) in coating, in pound of solids per pound of coating.

W_{VM} = weight fraction of volatile matter in coating, in pound of volatile matter per pound of coating. If this weight fraction is determined by ASTM ~~D2369-04~~D2369, "Standard Test Method for Volatile Content of Coatings," the drying conditions shall be one hundred ten degrees Celsius for one hour, except where otherwise authorized by the director based on an alternate analytical procedure that is satisfactorily demonstrated to the director by the coating manufacturer to be more representative of the actual cure mechanism of the coating.

W_W = weight fraction of water in coating, in pound of water per pound of coating.

- (5) If the coating contains a volatile matter other than VOC or water, the identity and content of such volatile matter may be determined using either standard gas chromatographic techniques or coating formulation data from the coating manufacturer and coating user. The density of such volatile matter may be determined using either the procedures set forth in ASTM ~~D1475-98~~(2012)D1475 or data from reference texts. For purposes of this method, such volatile matter shall be referred to as exempt solvent. The following may be determined, where appropriate:

D_{ES} = density of exempt solvent, in pounds of exempt solvent per gallon of exempt solvent.

V_{ES} = volume fraction of exempt solvent in coating, in gallon of exempt solvent per gallon of coating.

W_{ES} = weight fraction of exempt solvent in coating, in pound of exempt solvent per pound of coating.

- (6) The weight fraction W_{VOC} of VOC in a coating and the volume fraction V_{VOC} of VOC in a coating shall be calculated as follows, where appropriate:

$$W_{VOC} = W_{VM} - W_W - W_{ES}$$

$$V_{VOC} = V_{VM} - V_W - V_{ES}$$

- (7) The VOC content of a coating can be expressed as follows:

$C_{VOC,1}$ = VOC content in pounds of VOC per gallon of coating.

$C_{VOC,2}$ = VOC content in pounds of VOC per gallon of coating, excluding water and exempt solvents.

$C_{VOC,3}$ = VOC content in pounds of VOC per gallon of solids.

$C_{VOC,4}$ = VOC content in pounds of VOC per pound of solids.

$C_{VOC,5}$ = VOC content in percentage VOC by volume of the coating, excluding water and exempt solvents.

$C_{VOC,6}$ = VOC content in percentage VOC by volume of the volatile matter.

$C_{VOC,7}$ = VOC content in percentage VOC by weight of the coating.

(8) The VOC content of a coating shall be calculated as follows, where appropriate:

$$C_{VOC,1} = (D_C)(W_{VOC})$$

$$C_{VOC,2} = (D_C)(W_{VOC}) / (V_S + V_{VOC})$$

$$C_{VOC,3} = (D_C)(W_{VOC}) / V_S$$

$$C_{VOC,4} = W_{VOC} / W_S$$

$$C_{VOC,5} = (100)(V_{VOC}) / (V_S + V_{VOC})$$

$$C_{VOC,6} = (100)(V_{VOC}) / V_{VM}$$

$$C_{VOC,7} = (100)(W_{VOC})$$

(9) The weighted average VOC content of the coatings employed during a specified time period t shall be calculated as follows, where appropriate:

$$(C_{\text{VOC},1})_A = \frac{\sum_{i=1}^n C_{\text{VOC},1i} L_{Ci}}{\sum_{i=1}^n L_{Ci}}$$

$$(C_{\text{VOC},2})_A = \frac{\sum_{i=1}^n C_{\text{VOC},2i} L_{Ci} (V_{Si} + V_{\text{VOC}i})}{\sum_{i=1}^n L_{Ci} (V_{Si} + V_{\text{VOC}i})}$$

$$(C_{\text{VOC},3})_A = \frac{\sum_{i=1}^n C_{\text{VOC},3i} L_{Ci} V_{Si}}{\sum_{i=1}^n L_{Ci} V_{Si}}$$

$$(C_{\text{VOC},4})_A = \frac{\sum_{i=1}^n C_{\text{VOC},4i} L_{Ci} D_C W_{Si}}{\sum_{i=1}^n L_{Ci} D_C W_{Si}} \quad \text{or} \quad = \frac{\sum_{i=1}^n C_{\text{VOC},4i} M_{Ci}}{\sum_{i=1}^n M_{Ci}}$$

$$(C_{\text{VOC},5})_A = \frac{\sum_{i=1}^n C_{\text{VOC},5i} L_{Ci} (V_{Si} + V_{\text{VOC}i})}{\sum_{i=1}^n L_{Ci} (V_{Si} + V_{\text{VOC}i})}$$

$$(C_{\text{VOC},6})_A = \frac{\sum_{i=1}^n C_{\text{VOC},6i} L_{Ci} V_{\text{VM}i}}{\sum_{i=1}^n L_{Ci} V_{\text{VM}i}}$$

$$(C_{\text{VOC},7})_A = \frac{\sum_{i=1}^n C_{\text{VOC},7i} L_{Ci} D_{Ci}}{\sum_{i=1}^n L_{Ci} D_{Ci}} \quad \text{or} \quad = \frac{\sum_{i=1}^n C_{\text{VOC},7i} M_{Ci}}{\sum_{i=1}^n M_{Ci}}$$

where:

A = subscript denoting that the indicated VOC content is a weighted average of the coatings employed during time period t.

L_C = liquid volume of coating employed during time period t, in gallons of coating.

M_C = mass (weight) of coating employed during time period t, in pounds of coating.

i = subscript denoting a specific coating employed during time period t.

n = total number of coatings employed during time period t.

t = time period specified for the weighted average VOC content.

- (10) The density of the VOC content of a coating may be determined using either the procedures set forth in ASTM ~~D1475-98(2012)~~D1475 or data from reference texts. If ASTM ~~D1475-98(2012)~~D1475 is employed, the density shall be the arithmetic average of three determinations.
- (11) In the event of a dispute between coating formulation data and data obtained by analytical procedures, the data obtained by analytical procedures shall be employed, except as otherwise provided in paragraph (B)(12) of this rule.
- (12) If a VOC content value obtained by analytical procedures is higher than a VOC content value obtained by formulation data due to any VOC that is formed during baking or curing (i.e., cure volatiles), then the VOC content of the portion of the coating not subject to curing or baking shall be based on formulation data and the VOC content of the portion of the coating subject to curing or baking shall be based on analytical procedures. The portion of the coating subject to curing or baking shall be equal to the measured transfer efficiency for the coating applicator and object being coated. The approach described in this paragraph for determining the VOC content of a coating may be used only when the applicable VOC limitation is expressed in terms of pounds of VOC per gallon of deposited solids and the transfer efficiency test method is specified in this rule or rule 3745-21-09 of the Administrative Code. Also, in cases where analytical results and formulation data are combined for a waterborne coating, the interlaboratory precision adjustments specified in the analytical procedures shall not be applied to the analytical results.
- (C) Method for the determination of VOC concentration, VOC mass emission rate and VOC control equipment efficiency.

- (1) The provisions of this paragraph are generally applicable to the test methods employed to determine the VOC concentration and VOC mass emission rate for a gas stream or exhaust vent and the collection or control efficiency for any control equipment designed, installed, and operated for the purpose of reducing the emission of VOC. For purposes of this paragraph, "vapor collection system" also means capture system and "vapor control system" also means control system or control device.
- (2) The concentration of VOC in a gas stream or exhaust vent shall be determined by utilizing the following methods:
 - (a) USEPA method 25 or USEPA method 25A, as appropriate, for sources specified in paragraphs (C) to (L), (P), (R), (S), (U), (W) to (Y), (FF), (GG), (LL) to (NN) [if the control efficiency compliance option in (LL), (MM) or (NN) is chosen] and, (PP), (SS), (VV)(2), (XX)(1), (YY), (ZZ) (1)(a), (AAA)(1), and (BBB) of rule 3745-21-09 of the Administrative Code; or
 - (b) USEPA method 18 or USEPA method 25A, as appropriate, for sources specified in paragraphs (O)(3)(c)(iv), (O)(4)(a)(ii), (CC) to (EE), and (LL) to (NN) [if the ppmv compliance option in (LL), (MM) or (NN) is chosen] of rule 3745-21-09 of the Administrative Code.
- (3) The following procedures shall be included in any source testing or determination where applicable:
 - (a) The source shall be operated at or near maximum operating capacity during any testing and the measurement of the operating rate shall be made in a manner acceptable to the Ohio EPA.
 - (b) The VOC content of any coatings employed shall be sampled and analyzed in accordance with paragraph (B) of this rule.
 - (c) The capture efficiency of any vapor collection system used to transport the VOC emissions from their point of origin to the vapor control system shall be determined in accordance with USEPA methods 204 to 204F or the alternative capture efficiency testing protocols specified in the USEPA, Office of Air Quality Planning and Standards document entitled "Guidelines for determining capture efficiency."
 - (d) The control efficiency of any vapor control system used to reduce the emission of VOC shall be based upon an emissions test or a recovery test. For a vapor control system that destroys VOC (e.g., an incineration

system), either the streams entering and leaving the vapor control system shall be tested or, if acceptable to the director, the amount of VOC employed shall be measured and the gas stream leaving the vapor control system shall be tested. For a vapor control system that recovers VOC (e.g., a carbon adsorption system), either the gas streams entering and leaving the vapor control system shall be tested or, if acceptable to the director, the amounts of VOC employed and recovered or, employed and emitted, shall be measured or tested.

- (e) For the testing of a gas stream vented to a vapor control system, samples shall be taken simultaneously at the inlet and the outlet of the vapor control system.
- (f) For the testing of a gas stream, the sampling location, volumetric flow rate, molecular weight, carbon dioxide and oxygen contents, excess air, and water vapor content shall be determined in accordance with USEPA methods 1, 1A, 2, 2A, 2C, 2D, 3 and 4.
- (g) For gas streams tested by USEPA method 25 or 25A, the VOC emission rate shall be based upon the average of three test runs. Each run shall have a minimum duration of one hour and a minimum sample volume of .003 dry standard cubic meter, except that shorter sampling times or smaller volumes, when necessitated by process variables, may be found acceptable.
- (h) The control efficiency of the vapor control system shall be the per cent reduction in mass emissions of VOC between the inlet and the outlet of the vapor control system. If this efficiency is based upon an emissions test utilizing USEPA method 25 or 25A, the mass emissions of VOC as carbon shall be employed in the efficiency determination.
- (i) The capture efficiency of the vapor collection system shall be the per cent of total mass emissions of VOC emitted from the source which are vented to the vapor control system. If this efficiency is based upon an emissions test utilizing USEPA method 25 or 25A, the mass emissions of VOC as carbon shall be employed in the efficiency determination.
- (j) The overall control efficiency (in per cent) of any control equipment for VOC emissions shall be the vapor capture efficiency multiplied by the vapor control efficiency and divided by one hundred.
- (k) The total mass emission rate of VOC from a source equipped with control equipment shall be the sum of VOC emissions from the vapor control

system, VOC emissions not collected by the vapor collection system and VOC emissions from any losses associated with the vapor collection system and vapor control system.

- (4) The VOC mass emissions rate for a gas stream tested by USEPA method 18 shall be calculated as follows:

$$E_s = K Q_s \sum_{i=1}^n C_i M_i$$

where:

E_s = VOC mass emission rate for the gas stream, in kilograms of VOC per hour (kg VOC/hr).

$K = 2.494 \times 10^{-6}$ (gram mole-kilogram-minute per standard cubic meter-gram-ppmv-hour).

where the standard temperature for gram-mole per standard cubic meter is twenty degrees Celsius.

Q_s = volumetric flow rate of gas stream, in dry standard cubic meters per minute, at a standard temperature of twenty degrees Celsius.

C_i = concentration of sample component i , in ppmv, dry basis.

M_i = molecular weight of sample component i , in grams per gram-mole.

i = subscript denoting a specific sample component, which is a VOC, in the gas stream.

n = total number of sample components, which are VOC, in the gas stream.

- (5) The mass emission rate of VOC as carbon for a gas stream tested by USEPA method 25 shall be calculated as follows:

$$E_s = K C_s Q_s$$

where:

E_s = mass emission rate of VOC as carbon for the gas stream, in kilograms of carbon per hour (kg C/hr).

$K = 1 \times 10^{-6}$ kilograms per milligram.

C_s = concentration of VOC as carbon in the gas stream, in milligrams of carbon per dry standard cubic meter.

Q_s = volumetric flow rate of the gas stream, in dry standard cubic meters per hour.

- (6) To convert a mass emission rate from kilograms per hour to pounds per hour, multiply the mass emission rate in kilograms per hour by 2.2046.
- (7) To convert a mass emission value from VOC as carbon to VOC, divide the mass emission value of VOC as carbon by the weight fraction of carbon in the average molecular weight of the VOC emission. The determination of this weight fraction of carbon may be based on standard analytical techniques or material formulation data.

(D) Method for the determination of VOC emissions from solvent metal cleaning:

- (1) This method is applicable to determining VOC emissions from solvent metal cleaning equipment.
- (2) The purpose of this method is to quantify, by material balance, the amount of solvent input into a degreaser over a sufficiently long period of time so that an average emission rate can be computed.
- (3) The following procedure shall be followed to perform a material balance test:
 - (a) Clean the degreaser sump before testing.
 - (b) Record the amount of initial and make-up solvent added to the tank with a flow meter or other means.
 - (c) Record the type and amount or weight of work load degreased each day.
 - (d) At the end of the test run, pump out the used solvent and measure the amount with a flow meter or other means. Also, estimate the volume of metal chips and other material remaining in emptied sump, if significant.
 - (e) Bottle a sample of the used solvent and analyze it to find the per cent that is oil and other contaminants. The oil and solvent proportions can be estimated by weighing samples of used solvent before and after boiling off the solvent. Compute the volume of oils in the used solvent. The

volume of solvent displaced by this oil along with the volume of make-up solvent added during operations is equal to the amount of VOC emissions.

- (4) The following procedure can be followed to perform a material balance test in lieu of the procedure in paragraph (D)(3) of this rule:
 - (a) Clean the degreaser sump before testing.
 - (b) Record the amount of initial and make-up solvent added to the tank as measured with a flow meter or other means.
 - (c) Record the type and amount or weight of work load degreased over the period of the test.
 - (d) Record the amount of used solvent pumped out of the tank for disposal as measured with a flow meter or other means.
 - (e) Bottle a sample of the used solvent and analyze it to find the per cent that is oil and other contaminants.
 - (f) The VOC emissions from solvent metal cleaning equals the total solvent added to the tank minus the solvent contained in the used solvent being disposed.
- (E) Method for the determination of VOC emissions from bulk gasoline terminals.
 - (1) This method is applicable to determining the VOC emission rates at a bulk gasoline terminal employing a vapor collection system and either a continuous or intermittent vapor control system at a loading rack.
 - (2) The VOC emission rates shall be determined in accordance with the methods and procedures contained in 40 CFR 60.503(b), (c), (e) and (f) of "Subpart XX - Standards of Performance for Bulk Gasoline Terminals."
 - (3) During any test, all loading racks shall be open for each product line which is controlled by the system under test. Simultaneous use of more than one loading rack shall occur to the extent that such use would normally occur.
 - (4) Simultaneous use of more than one dispenser on each loading rack shall occur to the extent that such use would normally occur.
 - (5) Dispensing rates shall be set at the maximum rate at which the equipment is typically operated. Automatic product dispensers are to be used according to normal operating practices.

- (6) Applicable operating parameters of the vapor control system shall be monitored to demonstrate that the control unit is operating at design levels. Delivery devices shall be leak free.
 - (7) For each gasoline tank truck loaded during the test period, all potential sources of leaks shall be checked in accordance with the method specified in paragraph (K) of this rule. The tank identification number, the latest leak check certification date, and the location and highest detector reading for each incident of leakage shall be recorded.
 - (8) During each test, all potential sources of leaks in the vapor collection and control systems shall be monitored in accordance with the method specified in paragraph (K) of this rule. The location and highest detector reading for each incident of leakage shall be recorded.
- (F) Method for the detection of leaks of VOC from petroleum refinery equipment and organic chemical manufacturing equipment.
- (1) This method is applicable to the detection of leaks of VOC into the ambient air from petroleum refinery equipment and any chemical manufacturing equipment subject to paragraph (T) or (DD) of rule 3745-21-09 of the Administrative Code.
 - (2) The detection of leaks shall be determined in accordance with the test procedure set forth in USEPA method 21.
 - (3) The calibration gases shall conform to the following:
 - (a) Zero air, which consists of less than ten ppmv of hydrocarbon in air.
 - (b) A mixture of air and methane or n-hexane at a concentration of approximately, but less than, ten thousand ppmv of methane or n-hexane.
 - (4) The leak detection instrument shall be calibrated before use on each day of its use.
- (G) Standard method for the determination of the leak tightness of gasoline tank trucks (method G).
- (1) This method is applicable to determining the leak tightness of gasoline tank trucks which are equipped with piping, hoses and other devices for the collection or return of gasoline vapors during the transfer of gasoline at a gasoline dispensing facility, bulk gasoline plant or bulk gasoline terminal.

- (2) The leak tightness of a gasoline tank truck shall be determined in accordance with the test procedure set forth in USEPA method 27. For the pressure test, the initial pressure shall be 18.0 inches of water. For the vacuum test, the initial vacuum shall be 6.0 inches of water.
- (3) If any gasoline tank truck or compartment of a gasoline tank truck sustains either a pressure decrease greater than 3.0 inches of water over five consecutive minutes for the pressure test or a pressure increase greater than 3.0 inches of water over five consecutive minutes for the vacuum test, the tank truck is not leak tight. If not leak tight, repair the tank truck as necessary and repeat the entire test procedure specified in paragraph (G)(2) of this rule until the gasoline tank truck or compartment passes the test.

(H) [Reserved.]

(I) Method for the determination of seal gaps in an external floating roof tank.

- (1) This method is applicable to determining the width and area of any gaps between the wall of an external floating roof tank and a seal which is around the circumference of the external floating roof.
- (2) The width of any seal gap is the distance between the seal and the tank wall. It is determined by using probes of various widths to accurately measure the actual distance from the seal to the tank wall.
- (3) The area of any seal gap is determined by multiplying the width of the seal gap, as determined in paragraph (I)(2) of this rule, by the circumferential length of the gap.
- (4) The total seal gap area is the accumulated area of all gaps which are greater than 0.125 inch in width.

(J) Method for the determination of the perchloroethylene content of wastes at a dry cleaning facility which uses perchloroethylene.

- (1) The method is applicable to determining the perchloroethylene content in per cent by weight for waste at a dry cleaning facility from any distillation operation which distills perchloroethylene and from any diatomaceous earth filter which filters perchloroethylene.
- (2) The perchloroethylene content of the waste in per cent by volume is determined in accordance with the procedure in ASTM ~~D322-97(2012)~~D322, and is calculated as the diluent content in that procedure.

- (3) The density of the waste is determined by weighing a known volume of the waste and is calculated as the net weight of the waste in pounds divided by the volume of the waste in gallons.
 - (4) The perchloroethylene content of the waste in per cent by weight is calculated as the product of the waste diluent content and 13.55, divided by the waste density.
- (K) Method for the detection of leaks of gasoline vapors from vapor control systems, vapor collection systems, vapor balance systems, gasoline barges and gasoline tank trucks.
- (1) This method is applicable to the detection of leaks of gasoline vapors into the ambient air from the following:
 - (a) Vapor control systems, vapor collection systems, and vapor balance systems at barge loading facilities (for gasoline), bulk gasoline terminals, bulk gasoline plants, and gasoline dispensing facilities.
 - (b) Gasoline barges and gasoline tank trucks during loading, providing the vapor control system, vapor collection system, or vapor balance system which is connected to the gasoline barge or gasoline tank truck does not create a back pressure greater than eighteen inches of water gauge pressure.
 - (2) This method describes the procedures to be followed for detecting leaks of gasoline vapors by means of a portable hydrocarbon gas analyzer, which is calibrated to read in per cent of the lower explosive limit as propane.
 - (3) The following equipment are to be used:
 - (a) A liquid manometer, or equivalent device, capable of measuring up to twenty-five inches of water gauge pressure with a precision of plus or minus 0.1 inch of water.
 - (b) A portable hydrocarbon gas analyzer which conforms to the following:
 - (i) Is equipped with a sampling line of sufficient length for easy maneuverability during testing and a sampling probe having an internal diameter of 0.25 inch.
 - (ii) Is certified as safe for operation in explosive atmospheres.
 - (iii) Has a minimum range of zero to one hundred per cent of the lower explosive limit as propane.

- (iv) Has a response time for full-scale deflection of less than eight seconds with sampling line and probe attached.
- (4) The portable hydrocarbon gas analyzer is calibrated with 2.2 per cent propane by volume in air (or equivalent calibration gas) for one hundred per cent of the lower explosive limit according to the procedures and frequency specified by the manufacturer.
- (5) The test procedures for detecting leaks are the following:
- (a) Connect the liquid manometer to a pressure tap in the vapor control system, vapor collection system, or vapor balance system as close as possible to the connection with the gasoline barge or gasoline tank truck.
 - (b) Record the pressure periodically during loading of the gasoline barge or gasoline tank truck.
 - (c) Check with the portable hydrocarbon gas analyzer all potential leak sources on the gasoline barge or gasoline tank truck during loading and on the vapor control system, vapor collection system, or vapor balance system by doing the following:
 - (i) Maintaining the probe's inlet about one inch from the potential leak source in the path of (parallel to) the vapor flow from a leak.
 - (ii) Moving the probe slowly around the periphery of the potential leak source to locate the point of highest meter response.
 - (iii) Blocking as much as possible the wind from the area being monitored.
 - (d) Record the location of leakage and the highest detector reading for each incidence of leakage.
- (L) Method for the determination of the emission of volatile organic compounds from a dryer at a petroleum dry cleaning facility.
- (1) This method is applicable to determining the volatile organic compound emission rate of a dryer containing articles cleaned in petroleum solvent at a dry cleaning facility.
 - (2) The dryer shall be tested under normal operating conditions for at least thirty dryer loads that total not less than four thousand pounds dry weight of articles cleaned. The dryer loads shall represent a normal range of variations in fabrics,

solvents, load weights, temperatures, flow rates, and process deviations. Each dryer load shall be tested in accordance with paragraph (L)(3) or (L)(4) of this rule.

(3) For each dryer load the following shall be conducted and recorded:

- (a) Determine the average stack gas dry volumetric flow rate V (in dry standard cubic feet per hour) in accordance with USEPA methods 1 and 2.
- (b) Determine the average organic concentration C in the stack (in ppmv as propane) in accordance with USEPA method 25A in which the flame ionization analyzer is calibrated with propane standards.
- (c) Determine the ratio R of the flame ionization analyzer's response to a given parts per million by volume concentration of propane to ~~its~~the response to the same parts per million by volume concentration of the volatile organic compounds present in the stack gas.
- (d) Determine the molecular weight M (in pounds per pound-mole) of the volatile organic compounds present in the stack gas. Such determination shall be based on data from the manufacturer of the cleaning solvent or on standard analytical techniques.
- (e) Measure and record the weight W_a (in pounds dry weight) of the articles to be cleaned.
- (f) Calculate the weight W_{voc} (in pounds) of the volatile organic compounds emitted into the ambient air using the following equation:

$$W_{voc} = V \times C \times R \times M$$

(4) For each dryer load the following shall be conducted and recorded:

- (a) All weights shall be measured to the nearest 0.5 pound or less on a scale that is accurate to 0.5 pound at weights of up to two hundred pounds.
- (b) Measure and record the weight W_a (in pounds) of the articles to be cleaned.
- (c) Measure and record the initial weight W_i (in pounds) of the articles to be dried after the washing cycle.
- (d) Measure and record the final weight W_f (in pounds) of the articles removed from the dryer after the drying cycle.

- (e) Measure and record the weight W_r (in pounds) of any recovered liquid materials.
- (f) Calculate the weight W_{VOC} (in pounds) of the volatile organic compounds emitted into the ambient air using the following equation:

$$W_{VOC} = W_i - W_f - W_r$$

- (5) The dryer's volatile organic compound emission rate (in pounds per one hundred pounds dry weight of articles cleaned) shall be calculated for the combined dryer loads tested under this method as equal to one hundred multiplied by the sum total of W_{VOC} and divided by the sum total of W_a .
- (M) Method for the determination of the amount of volatile organic compounds contained in filtration waste at a petroleum dry cleaning facility.
- (1) This method is applicable to determining the amount of volatile organic compounds contained in the waste from a solvent filter used to filter petroleum solvent at a dry cleaning facility.
 - (2) The solvent filter shall be tested under normal operating conditions for at least three time periods according to the procedures specified in paragraph (M)(3) of this rule.
 - (3) The test procedures for each time period are as follows:
 - (a) A time period consists of the time immediately after the removal of waste from the solvent filter up to the next removal of waste.
 - (b) Record the date and time of the start of the time period.
 - (c) Record during the time period the weight of articles being cleaned in any washer connected to the solvent filter.
 - (d) Record the weight of the waste from the solvent filter at the end of the time period, in pounds.
 - (e) Collect in a sealed container, which is impervious to petroleum solvent, about two pounds of the waste from the solvent filter at the end of the time period.
 - (f) Record the date and time of the end of the time period.

- (g) Conduct a laboratory analysis of the waste collected in the sealed container according to the procedures specified in paragraph (M)(4) of this rule.
- (4) The procedures for the laboratory analysis of the collected filtration waste are as follows:
- Determine the weight W_s (in grams of a sample of approximately fifty milliliters of the filtration waste).
 - Determine the volume V_s (in milliliters) of the diluent content of that sample in accordance with ASTM ~~D322-97(2012)~~D322.
 - Calculate the sample's diluent content D_s (fraction diluent by weight) using the following equation:

$$D_s = (0.78 \times V_s) / W_s$$

STRIKE OLD

$$D_s = \frac{0.78 \times V_s}{W_s}$$

where 0.78 is the typical density of petroleum solvent in grams per milliliter.

- (5) For the test conducted under paragraphs (M)(2), (M)(3) and (M)(4) of this rule, the amount of VOCs contained in the filtration waste is calculated using the following equation:

$$X = ((W_1D_1 + W_2D_2 + W_3D_3) / (A_1 + A_2 + A_3)) \times 100$$

STRIKE OLD

$$X = \frac{W_1D_1 + W_2D_2 + W_3D_3}{A_1 + A_2 + A_3} \times 100$$

where:

X = amount of VOCs in the filtration waste, in pounds of VOC per one hundred pounds dry weight of articles cleaned.

A = total weight of articles cleaned during the time period indicated, in pounds dry weight.

D = diluent content of the sample of filtration waste for the time period indicated, in fraction diluent by weight (pounds of diluent per pound of filtration waste).

W = total weight of filtration waste for the time period indicated.

Subscripts 1, 2, and 3 identify the time period of the test.

(N) Method for the determination of the length of time to operate the recovery cycle of a solvent recovery dryer at a petroleum dry cleaning facility.

- (1) This method is applicable to determining the length of time for operating the solvent recovery cycle of a solvent recovery dryer at a petroleum dry cleaning facility in order to assure that the flow rate of recovered petroleum solvent at the termination of solvent recovery cycle is no greater than fifty milliliters per minute.
- (2) The dryer shall be tested under normal operating conditions for a duration of no less than two weeks during which no less than one-half of the dryer loads shall be monitored for their final recovered solvent flow rate.
- (3) The suggested point for measuring the flow rate of recovered solvent is from the outlet of the solvent-water separator. Near the end of the recovery cycle, the entire flow of recovered solvent is diverted to a graduated cylinder. As the recovered solvent collects in the graduated cylinder, the elapsed time is monitored and recorded in periods greater than or equal to one minute. At the same time, the volume of solvent in the graduated cylinder is monitored and recorded to determine the volume of recovered solvent that is collected during each time period. The recovered solvent flow rate is calculated by dividing the volume of solvent collected per period by the length of time elapsed during the period and converting the result with appropriate factors into units of milliliters per minute. The recovery cycle and the monitoring procedure is continued until the flow rate of solvent is less than or equal to fifty milliliters per minute. The date, the type of articles cleaned, and the total length of the recovery cycle shall be recorded for each dryer load being monitored.

(O) Method for the determination of equipment in VOC service and in light liquid service.

- (1) This method is applicable to equipment at a petroleum refinery or a process unit subject to paragraph (T) or (DD) of rule 3745-21-09 of the Administrative Code.

- (2) Any piece of equipment is presumed to be in VOC service, unless the owner or operator demonstrates that the piece of equipment is not in VOC service according to the following provisions:
- (a) The piece of equipment is considered not in VOC service if it can be determined that the VOC content of the process fluid, which is contained in or contacts the piece of equipment, can be reasonably expected never to exceed ten per cent by weight.
 - (b) For purposes of determining the VOC content of a process fluid, procedures that conform to the general methods described in ASTM ~~E168-06~~E168, ASTM ~~E169-04(2009)~~E169, and ASTM ~~E260-96(2011)~~E260 shall be used.
 - (c) The owner or operator may use engineering judgment rather than the procedures contained in paragraph (O)(2)(b) of this rule to demonstrate that the VOC content of a process fluid does not exceed ten per cent by weight, provided the VOC content clearly does not exceed ten per cent by weight. In the event the Ohio EPA or the USEPA has a disagreement with an engineering judgment, paragraph (O)(2)(b) of this rule shall be used to resolve the disagreement.
- (3) A piece of equipment is in light liquid service if it contains or is in contact with a process fluid that meets all of the following conditions:
- (a) The process fluid is a liquid at operating conditions.
 - (b) The vapor pressure of one or more of the pure components within the process fluid is greater than 0.04 pound per square inch at sixty-eight degrees Fahrenheit. Vapor pressures may be obtained from standard reference texts or may be determined by the method in ASTM ~~D2879-10~~D2879.
 - (c) The total concentration of the pure components having a vapor pressure greater than 0.04 pound per square inch at sixty-eight degrees Fahrenheit is equal to or greater than twenty per cent by weight.
- (P) Method for the determination of the net heating value of a gas, the actual exit velocity for a flare, and the maximum permitted velocity for an air-assisted flare.
- (1) This method is applicable to the following:
- (a) Any flare subject to paragraph (DD) of rule 3745-21-09 of the Administrative Code.

(b) Any process vent stream subject to paragraph (EE) of rule 3745-21-09 of the Administrative Code.

- (2) The net heating value of gas being combusted in a flare or being vented from a process vent stream shall be calculated using the following equation:

where:

$$H_T = k \sum_{i=1}^n C_i H_i$$

H_T = net heating value of the sample, in mega joules per standard cubic meter (MJ/scm), where the net enthalpy per mole of offgas is based on combustion at twenty-five degrees Celsius and seven hundred sixty millimeters of mercury, but the standard temperature for determining the volume corresponding to one mole is twenty degrees Celsius.

k = constant, 1.740×10^{-7} (megajoule-gram mole per parts per million-standard cubic meter-kilocalorie), where the standard temperature for gram-mole per standard cubic meter (g mole/scm) is twenty degrees Celsius.

C_i = concentration of sample component i in ppmv, as measured by the procedures in USEPA method 18, and ASTM ~~D1946-90~~(2011)D1946 reported on a wet basis.

H_i = net heat of combustion of sample component i , in kilocalories per gram-mole. The heat of combustion may be determined using the procedures in ASTM ~~D2382-76~~D2382 if published values are not available or cannot be calculated.

i = subscript denoting a specific component in the sample.

n = total number of components within the sample.

- (3) The actual exit velocity of a flare shall be calculated by dividing the volumetric flow rate (in units of standard temperature and pressure) of the flare header or headers that feed the flare, as determined by USEPA methods 2, 2A, 2C, or 2D as appropriate, by the unobstructed (free) cross-sectional area of the flare tip, as determined by design and engineering principles.
- (4) The maximum permitted velocity of an air-assisted flare shall be determined by the following equation:

$$V_{\max} = 8.706 + 0.7084 (H_T)$$

where:

V_{\max} = maximum permitted velocity of an air-assisted flare, in meters per second (m/sec).

H_T = the net heating value as determined in paragraph (P)(2) of this rule.

- (5) To express the net heating value of a gas in Btu per standard cubic foot, multiply H_T by 26.84.
 - (6) To express a velocity in feet per second, multiply the velocity in meters per second by 3.281.
- (Q) Method for the detection of leaks of gasoline vapors from a vapor control system installed at a gasoline dispensing facility (static leak test).
- (1) This method is applicable to quantifying the vapor tightness of a vapor balance system or a vacuum assist control system installed at a gasoline facility.
 - (2) This method describes the procedures to be followed for detecting leaks of gasoline vapors by pressurizing the entire vapor recovery control system to two inches of water column and then allowing the system pressure to decay for five minutes. The acceptability of the final pressure is based upon the vapor system volume or ullage space. The allowable five minute final pressure is based upon the gasoline tank ullage, pressure decay equations, and the number of affected nozzles.
 - (3) The equipment, procedures, and pressure decay leak criteria are specified in appendix A to this rule.
- (R) Method for the determination of the dynamic pressure performance for a vapor control system installed at a gasoline dispensing facility (dynamic pressure performance test).
- (1) This method is applicable to determining the dynamic pressure at known dispensing flow rates for a vapor control system installed at a gasoline dispensing facility. This method is used to quantify the back pressure and detect liquid obstructions in the vapor path leading from the dispensing nozzle to the gasoline storage tank.
 - (2) This method describes the procedures to be followed in simulating the dynamic back pressures associated with known gasoline dispensing rates and liquid

blockages by passing nitrogen through the vapor control system at three flow rates after liquid gasoline has been introduced into the vapor return piping.

- (3) The equipment, procedures, and dynamic pressure performance criteria are identified in appendix B to this rule. The post test inspection form, as required by paragraph (DDD)(2)(c) of rule 3745-21-09 of the Administrative Code, is contained in appendix C to this rule.
- (S) Inspection and maintenance requirements for catalytic incinerators. An inspection and maintenance plan shall be developed, maintained on-site, and made readily available upon the request of the appropriate Ohio EPA district office or local air agency. At a minimum, the plan shall include the following:
- (1) Annual sampling and analysis of the catalyst activity (i.e., conversion efficiency) following the manufacturer's or catalyst supplier's recommended procedures.
 - (2) Monthly inspection of the oxidizer system including the burner assembly and fuel supply lines for problems.
 - (3) Annual internal and monthly external visual inspection of the catalyst bed to check for channeling, abrasion, and settling. If problems are found, corrective action consistent with the manufacturer's recommendations shall be implemented and a new performance test to determine destruction efficiency in accordance with paragraph (C) of this rule shall be conducted.
 - (4) Records, and a description of the results of each inspection and catalyst activity analysis.

Effective: 3/27/2022
Five Year Review (FYR) Dates: 11/29/2021 and 11/29/2026

CERTIFIED ELECTRONICALLY

Certification

03/17/2022

Date

Promulgated Under: 119.03
Statutory Authority: 3704.03(E)
Rule Amplifies: 3704.03(A), 3704.03(E)
Prior Effective Dates: 10/19/1979, 03/27/1981, 06/21/1982, 01/24/1983,
05/09/1986, 05/25/1988, 08/22/1990, 03/31/1993,
01/17/1995, 06/15/1999, 11/05/2002, 08/25/2008,
10/15/2015, 02/16/2019

3745-21-10

Appendix A

1

-STATIC LEAK TEST

(taken from BAAQMD test procedure ST-30)

1. Applicability

- 1.1** This test procedure is used to quantify the vapor tightness of vapor control systems installed at any gasoline dispensing facility (GDF) equipped with pressure/vacuum (P/V) valves, provided that the designed pressure setting of the P/V valves is a minimum of 2.5 inches of water column (inches H₂O). Excessive leaks in the vapor control system will increase the quantity of fugitive hydrocarbon emissions and lower the overall efficiencies of both the Stage I and Stage II vapor control systems.
- 1.2** For those systems equipped with a P/V valve allowed to have a designed cracking pressure less than 2.5 inches H₂O, the valve shall be bagged to eliminate, from the test results, any flow contribution through the valve assembly. The valve/vent pipe connection, however, shall remain unobstructed during this test.
- 1.3** For those facilities not required to be equipped with a P/V valve, the vent pipe shall be capped. For these installations, the test may be conducted at the vent pipe.

2. Principle

- 2.1** The entire vapor control system is pressurized with nitrogen to two (2.0) inches H₂O. The system pressure is then allowed to decay and the pressure after five (5) minutes is compared with an allowable value. The minimum allowable five-minute final pressure is based on the system ullage and pressure decay equations. For the purpose of compliance determination, this test shall be conducted after all back-filling, paving, and installation of all Stage I and Stage II components, including P/V valves, has been completed.
- 2.2** For a GDF equipped with a coaxial Stage I system this test shall be conducted at a Stage II vapor riser. For a GDF which utilizes a two-point Stage I system this test shall be conducted at the Stage I vapor coupler, provided that the criteria set forth in Section 6.7 have been met. If the integrity criteria for two-point systems specified in Section 6.7 are met, this test shall be conducted at the Stage I vapor coupler unless the vapor control system possesses a design which is incompatible with testing at this location.

3. Range

- 3.1** If mechanical pressure gauges are employed, the full-scale range of the pressure gauges shall be 0-2.0, 0-1.0, and 0-0.50 inches H₂O column. Maximum incremental graduations of the pressure gauge shall be 0.05 inches H₂O and the minimum accuracy of the gauge shall be three percent of full scale. The minimum diameter of the pressure gauge face shall be 4 inches.
- 3.2** If an electronic pressure measuring device is used, the full-scale range of the device shall not exceed 0-10 inches H₂O with a minimum accuracy of 0.5 percent of full-scale. A 0-20 inches H₂O device may be used, provided the equivalent accuracy is not less than 0.25 percent of full scale.
- 3.3** The minimum ullage during the test shall be 25 percent of the tank capacity (total of **all** tanks if manifolded) or 500 gallons, whichever is greater. The maximum total ullage shall be 25,000 gallons. These values are exclusive of all vapor piping volumes.
- 3.4** The minimum and maximum nitrogen feed-rates, into the system, shall be one (1) and five (5) CFM, respectively.

4. Interferences

- 4.1** Nitrogen shall not be introduced into the system at flowrates exceeding five (5) CFM as this may bias the results of the test toward non-compliance.
- 4.2** For vacuum-assist Stage II systems which utilize an incinerator, power to the collection unit shall be turned off during testing.
- 4.3** For vacuum-assist systems which locate the vacuum producing device in-line, between the Stage II vapor riser and the storage tank, the following shall apply:
 - 4.3.1** A valve shall be installed at the vacuum producing device. When closed, this valve shall isolate the vapor passage downstream of the vacuum producing device.
 - 4.3.2** The storage tank side of the vacuum producing device shall be tested in accordance with the procedures outlined in Section 7 of this method. Compliance shall be determined by comparing the final five-minute pressure with the allowable minimum five-minute final pressure from the first column (1-6 affected nozzles) in Table IB or use the corresponding equation in Section 9.2.

4.3.3 The upstream vapor passage (nozzle to vacuum producing device) shall also be tested. Methodology for this test shall be submitted to the Ohio EPA, Division of Air Pollution Control for approval prior to submission of test results or shall be conducted in accordance with the procedures set forth in the applicable CARB Executive Order.

5. Apparatus

- 5.1** Nitrogen. Use commercial grade nitrogen in a high pressure cylinder, equipped with a two-stage pressure regulator and a one psig pressure relief valve. A one psig (maximum) pressure relief valve is required and **must** be present. In addition, the cylinder of nitrogen **must** be grounded.
- 5.2** Pressure Measuring Device. Use 0-2.0, 0-1.0, and 0-0.50 inches H₂O pressure gauges connected in parallel, a 0-2 inches H₂O manometer, or an electronic pressure measuring device to monitor the pressure decay in the vapor control system. The pressure measuring device shall, at a minimum, be readable to the 0.05 inches H₂O.
- 5.3** "T" Connector Assembly. See Figure 1 for example.

Figure 1

"T" Connector Assembly

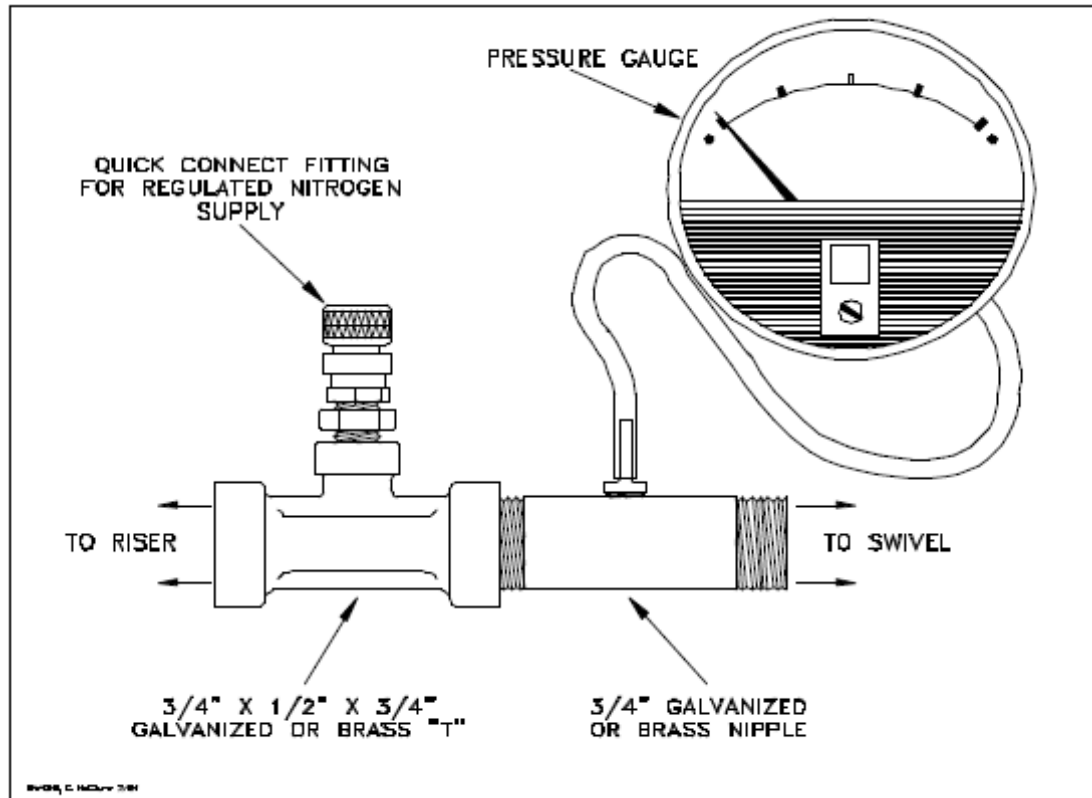

- 5.4 Vapor Coupler Integrity Assembly. Assemble OPW 633-A, 633-B, AND 634-A adapters, or equivalent, as shown in Figure 2. If the test is to be conducted at the storage tank Stage I vapor coupler, this assembly shall be used prior to conducting the static leak test in order to verify the pressure integrity of the vapor poppet. The internal volume of this assembly shall not exceed 0.1 cubic feet.

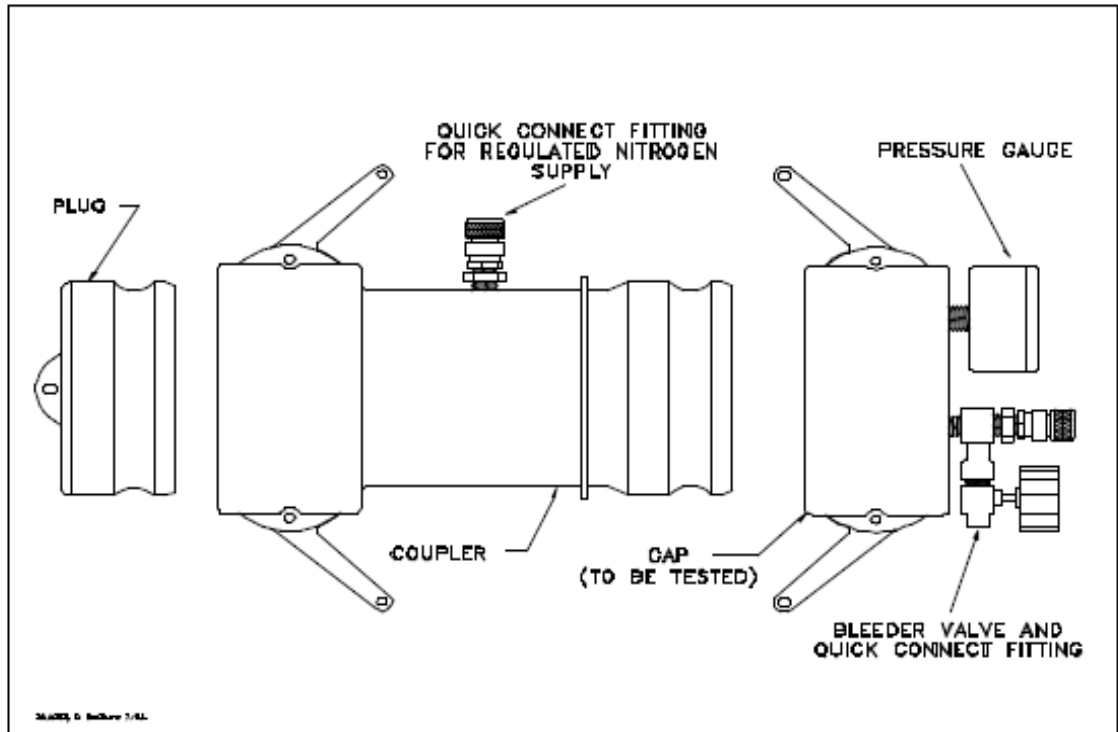
Figure 2**Vapor Coupler Integrity Assembly**

- 5.5** Vapor Coupler Test Assembly. Use a compatible OPW 634-B cap, or equivalent, equipped with a center probe to open the poppet, the appropriate pressure measuring device to monitor the pressure decay, and a connection for the introduction of nitrogen into the system. See Figure 3 for example.

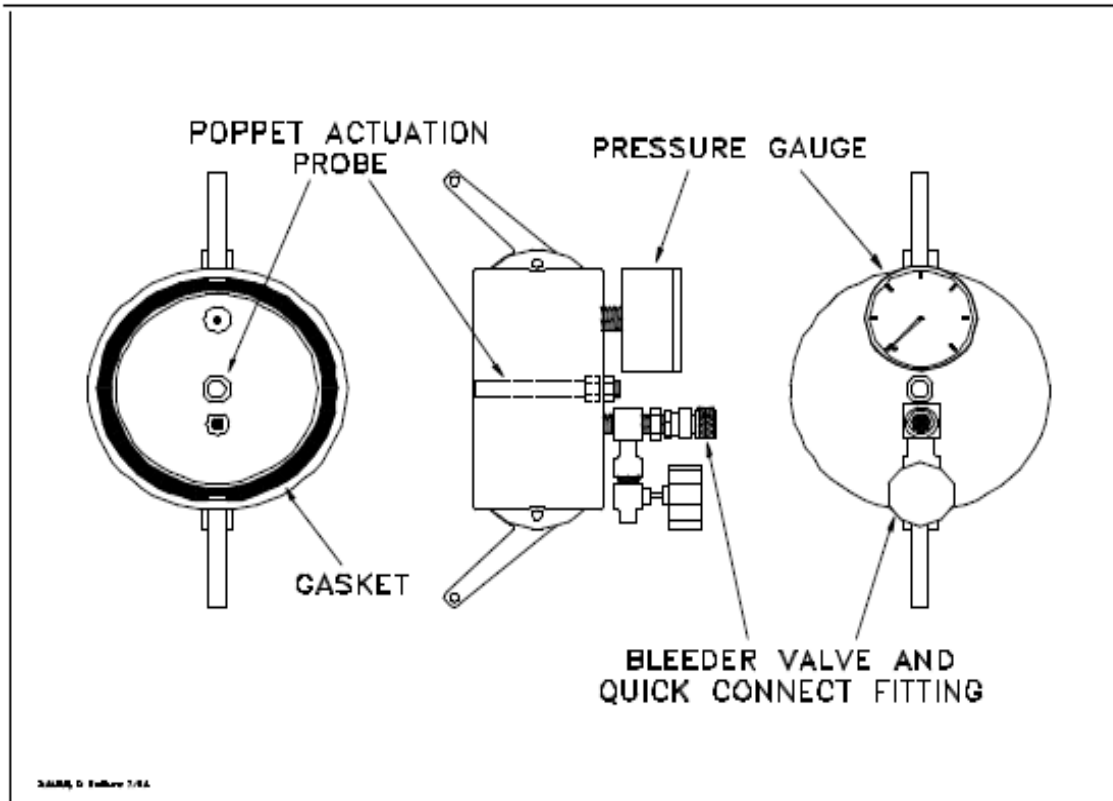
Figure 3**Vapor Coupler Test Assembly**

- 5.6** Stopwatch. Use a stopwatch accurate to within 0.2 seconds.
- 5.7** Flowmeter. Use a Dwyer flowmeter, Model RMC-104, or equivalent, to determine the required pressure setting of the delivery pressure gauge on the nitrogen supply pressure regulator. This pressure shall be set such that the nitrogen flowrate is between 1.0 and 5.0 CFM.
- 5.8** Combustible Gas Detector. A Bacharach Instrument Company, Model 0023-7356, or equivalent, may be used to verify the pressure integrity of system components during this test.
- 5.9** Leak Detection Solution. Any liquid solution designed to detect vapor leaks may be used to verify the pressure integrity of system components during this test.

6. Pre-Test Procedures

- 6.1** The following safety precautions shall be followed:
 - 6.1.1** Only grounded nitrogen shall be used to pressurize the system.
 - 6.1.2** A one psig relief valve shall be installed to prevent the possible over-pressurizing of the storage tank.
- 6.2** Product dispensing shall not occur during the test. There shall have been no Stage I deliveries into or out of the storage tanks within the three hours prior to the test. For vacuum-assist Stage II systems, product dispensing shall not occur during the thirty minutes immediately prior to the test.
- 6.3** Measure the gallons of gasoline present in each underground storage tank and determine the actual capacity of each storage tank from facility records. Calculate the ullage space for each tank by subtracting the gasoline gallonage present from the actual tank capacity. The minimum ullage during the test shall be 25 percent of the tank capacity (total of **all** tanks if manifolded) or 500 gallons, whichever is greater. The total ullage shall not exceed 25,000 gallons.
- 6.4** For two-point Stage I systems, this test shall be conducted with the dust cap removed from the vapor coupler. This is necessary to determine the vapor tightness of the Stage I vapor poppet. See Section 6.7 if this test is to be conducted at the Stage I vapor coupler.
 - 6.4.1** For coaxial Stage I systems this test shall be conducted with the dust cap removed from the Stage I coupler. This is necessary to insure the vapor tightness of the Stage I vapor poppet.
 - 6.4.2** Verify that the liquid level in the storage tank is at least four (4) inches above the highest opening at the bottom of the submerged drop tube.
- 6.5** If the Stage I containment box is equipped with a drain valve, the valve assembly may be cleaned and lubricated prior to the test. This test shall, however, be conducted with the drain valve installed and the manhole cover removed. See subsection 7.4.1 for further details regarding containment box drain valves.
- 6.6** If the test is to be conducted at a Stage II vapor riser, disconnect the dispenser end of one vapor control hose and install the "T" connector assembly (see Figure 1).

Connect the nitrogen gas supply (do not use air) and the pressure measuring device to the "T" connector.

- 6.6.1** For those Stage II systems utilizing a dispenser mounted remote vapor check valve, the "T" connector assembly shall be installed on the vapor riser side of the check valve.
- 6.7** If this test is to be conducted at the Stage I vapor coupler on a two-point Stage I system, the procedures set forth in subsections 6.7.1 and 6.7.2 shall be successfully completed prior to testing. The static leak test shall not be conducted at the Stage I coupler at facilities equipped with coaxial Stage I systems.
- 6.7.1** Connect the Vapor Coupler Integrity Assembly to the Stage I vapor coupler. Connect the Vapor Coupler Test Assembly. Connect the nitrogen supply to the assembly and carefully pressurize the internal volume of the assembly to two (2.0) inches H₂O. Start the stopwatch. Record the final pressure after one minute.
- 6.7.2** If the pressure after one minute is less than 0.25 inches H₂O, the leak rate through the Stage I vapor poppet precludes conducting the static leak test at this location. Repair or replace the faulty component(s) as necessary and restart the test pursuant to Section 6.7.1. If the pressure after one minute is greater than or equal to 0.25 inches H₂O, the static leak test may be conducted at this location. This criteria assures a maximum leak rate through the Stage I vapor poppet of less than 0.0004 cubic feet per minute.
- 6.7.3** Disconnect the Vapor Coupler Integrity Assembly from the Stage I vapor coupler. If the requirements of subsection 6.7.2 were met, install the Vapor Coupler Test Assembly to the Stage I vapor coupler.
- 6.8** All pressure measuring device shall be bench calibrated using either a reference gauge or incline manometer. Calibration shall be performed at 20, 50, and 80 percent of full scale. Accuracy shall be within two percent at each of these calibration points. Calibrations shall be conducted on a frequency not to exceed 90 days. The individual conducting the test shall supply to the Ohio EPA or its designated local air agency with proof of equipment calibration meeting the requirements of this Section.
- 6.9** Use the flowmeter to determine the nitrogen regulator delivery pressures which correspond to nitrogen flowrates of 1.0 and 5.0 CFM. These pressures define the allowable range of delivery pressures acceptable for this test procedure. Also

record which regulator delivery pressure setting, and the corresponding nitrogen flowrate, will be used during the test.

- 6.10** Use Equation 9.3 to calculate the approximate time required to pressurize the system ullage to the initial starting pressure of two (2.0) inches H₂O. This will allow the tester to minimize the quantity of nitrogen introduced into those systems which cannot comply with the static leak standards.
- 6.11** Attach the Vapor Coupler Test assembly to the Stage I poppet or the "T" connector assembly to the Stage II vapor riser. Read the initial pressure of the storage tank and underground piping. If the initial pressure is greater than 0.5 inches H₂O, carefully bleed off the pressure, in accordance with all applicable safety procedures, in the storage tank and underground piping to less than 0.5 inches H₂O column.

7. Testing

- 7.1** Open the nitrogen gas supply valve and set the regulator delivery pressure within the allowable range determined in Section 6.9, and start the stopwatch. Pressurize the vapor system (or subsystem for individual vapor return line systems) to **at least** 2.2 inches H₂O initial pressure. It is critical to maintain the nitrogen flow until the pressure stabilizes, indicating temperature and vapor pressure stabilization in the tanks. Check the test equipment using leak detecting solution or a combustible gas detector to verify that all test equipment is leak tight.
 - 7.1.1** If the time required to achieve the initial pressure of two (2.0) inches H₂O exceeds twice the time derived from Equation 9.3, stop the test and use liquid leak detector, or a combustible gas detector, to find the leak in the system. Repair or replace the faulty component and restart the test pursuant to Section 7.1.
- 7.2** Close and disconnect the nitrogen supply. Start the stopwatch when the pressure has decreased to the initial starting pressure of two (2.0) inches H₂O.
- 7.3** At one-minute intervals during the test, record the system pressure. After five minutes, record the final system pressure. See the applicable of Table IA (or Equation 9.1) or IB (or Equation 9.2) to determine the acceptability of the final system static pressure results. For intermediate values of ullage in Table IA and IB, linear interpolation may be employed.
- 7.4** If the system failed to meet the criteria set forth in Table I (or the appropriate equation in Section 9), repressurize the system and check all accessible vapor

connections using leak detector solution or a combustible gas detector. If vapor leaks in the system are encountered, repair or replace the defective component and repeat the test. Potential sources of leaks include nozzle check valves, pressure/vacuum relief valves, containment box drain valve assemblies, and plumbing connections at the risers.

7.4.1 If the facility fails to comply with the static leak test standards and the Stage I system utilizes a non-CARB-certified drain valve equipped containment box, which was installed prior to July 1, 1992, for which a CARB-certified replacement drain valve assembly is not marketed, the following two subsections shall apply:

7.4.1.1 The drain valve may be removed and the port plugged. Retest the system. If the facility complies with the static leak test standards under these conditions, the facility shall be considered complying with the requirements, provided that the manufacturer and model number of the containment box and the date of installation are submitted with the test results.

7.4.1.2 The criteria set forth in subsection 7.4.1.1 shall not apply after July 1, 1996.

7.5 After the remaining system pressure has been relieved, remove the Vapor Coupler Test Assembly or "T" connector assembly and reconnect the vapor control hose, if applicable.

7.6 If the vapor control system utilizes individual vapor return lines, repeat the leak test for each gasoline grade. Avoid leaving any vapor return line open longer than is necessary to install or remove the "T" connector assembly.

8. Post-Test Procedures

8.1 Use the applicable of Table IA or IB, or the applicable of Equations 9.1 or 9.2, to determine the compliance status of the facility by comparing the final five-minute pressure with the minimum allowable final pressure.

8.1.1 For balance Stage II systems use Table IA or the applicable of Equation 9.1 to determine compliance.

8.1.2 For vacuum-assist Stage II systems use Table IB or the applicable of Equation 9.2 to determine compliance.

9. Calculations

9.1 For Stage II Balance Systems, the minimum allowable five-minute final pressure, with an initial pressure of two (2.0) inches H₂O, shall be calculated as follows:

[Equation 9-1]

$$P_f = 2 e^{\frac{-760.490}{V}} \quad \text{if } N = 1-6$$

$$P_f = 2 e^{\frac{-792.196}{V}} \quad \text{if } N = 7-12$$

$$P_f = 2 e^{\frac{-824.023}{V}} \quad \text{if } N = 13-18$$

$$P_f = 2 e^{\frac{-855.974}{V}} \quad \text{if } N = 19-24$$

$$P_f = 2 e^{\frac{-888.047}{V}} \quad \text{if } N > 24$$

Where:

N = The number of affected nozzles. For manifolded systems, N equals the total number of nozzles. For dedicated plumbing configurations, N equals the number of nozzles serviced by the tank being tested.

P_f = The minimum allowable five-minute final pressure, inches H₂O

e = A dimensionless constant approximately equal to 2.718

2 = The initial starting pressure, inches H₂O

V = The total ullage affected by the test, gallons

9.2 For Stage II Vacuum Assist Systems, the minimum allowable five-minute final pressure, with an initial pressure of two (2.0) inches H₂O, shall be calculated as follows:

[Equation 9-2]

$$P_f = 2 e^{\frac{-500.887}{V}} \quad \text{if } N = 1-6$$

$$P_f = 2e^{\frac{-531.614}{V}} \quad \text{if } N = 7-12$$

$$P_f = 2e^{\frac{-562.455}{V}} \quad \text{if } N = 13-18$$

$$P_f = 2e^{\frac{-593.412}{V}} \quad \text{if } N = 19-24$$

$$P_f = 2e^{\frac{-624.483}{V}} \quad \text{if } N > 24$$

Where:

N = The number of affected nozzles. For manifolded systems, N equals the total number of nozzles. For dedicated plumbing configurations, N equals the number of nozzles serviced by the tank being tested.

P_f = The minimum allowable five-minute final pressure, inches H₂O

e = A dimensionless constant approximately equal to 2.718

2 = The initial starting pressure, inches H₂O

V = The total ullage affected by the test, gallons

- 9.3** The minimum time required to pressure the system ullage to two (2.0) inches H₂O shall be calculated as follows:

[Equation 9-3]

$$t_2 = V / (1522)F$$

Where:

t_2 = The minimum time to pressurize the ullage to two inches H₂O, minutes

V = The total ullage affected by the test, gallons

F = The nitrogen flowrate into the system, CFM

1522 = The conversion factor for pressure and gallons

- 9.4** If the policy of the local district requires an allowable tolerance for testing error, the minimum allowable five-minute final pressure, including testing error, shall be calculated as follows:

[Equation 9-4]

$$P_{f-E} = 2 - \left[1 + \left(\frac{E}{100} \right) \right] [408.9 - (P_f + 406.9)]$$

Where:

- P_{f-E} = The minimum allowable five-minute final pressure including allowable testing error, inches H₂O
 E = The allowable testing error, percent
 P_f = The minimum allowable five-minute final pressure calculated in Equations 9-1 or 9-2, inches H₂O
 2 = The initial starting pressure, inches H₂O
 408.9 = Atmospheric pressure plus the initial starting pressure, inches H₂O
 406.9 = Atmospheric pressure, inches H₂O

10. Reporting

- 10.1** The calculated ullage and system pressures for each five-minute vapor control system test shall be reported as shown in Form 1. Be sure to include the Stage I system type (two-point or coaxial), the Stage II system type, whether the system is manifolded, and the one-minute pressures during the test. The tester may either provide all information listed in Form 1 in the comprehensive test report or include a copy of this form along with the comprehensive written report.

Form 1

Source Test Results
Static Leak Test

Date: _____ Time: _____ Application No. _____

GDF Name and address: _____

Stage II system (check one): Vapor Balance Vacuum Assist Type: _____

Stage I type (check one): Two point Coaxial Manifolder? Yes No

Tank #				
Product grade				
Actual tank capacity (gallons)				
Gasoline volume (gallons)				
Ullage (gallons)				
Initial pressure of UST, inches H ₂ O				
Number of nozzles served by tank				
Test location: (A) Stage I vapor coupler or (B) Stage II riser				
Initial Pressure, inches H ₂ O (2.0)				
Pressure after 1 min. (inches H ₂ O)				
Pressure after 2 min. (inches H ₂ O)				
Pressure after 3 min. (inches H ₂ O)				
Pressure after 4 min. (inches H ₂ O)				
Final Pressure after 5 min. (inches H₂O)				
Allowable Final Pressure: Table IA, Table 1B, Equations 9.1, 9.2				
Test Status [Pass or Fail]				

Tests Conducted By: _____

Test Company: _____

Date of Tests: _____

Tests Witnessed By: _____

TABLE IA**STAGE II BALANCE SYSTEMS****PRESSURE DECAY LEAK RATE CRITERIA****INITIAL PRESSURE OF 2 INCHES OF H₂O****MINIMUM PRESSURE AFTER 5 MINUTES, INCHES OF H₂O**

<u>ULLAGE, GALLONS</u>	NUMBER OF AFFECTED NOZZLES				
	<u>01-06</u>	<u>07-12</u>	<u>13-18</u>	<u>19-24</u>	<u>≥ 24</u>
500	0.44	0.41	0.38	0.36	0.34
550	0.50	0.47	0.45	0.42	0.40
600	0.56	0.53	0.51	0.48	0.46
650	0.62	0.59	0.56	0.54	0.51
700	0.67	0.64	0.62	0.59	0.56
750	0.73	0.70	0.67	0.64	0.61
800	0.77	0.74	0.71	0.69	0.66
850	0.82	0.79	0.76	0.73	0.70
900	0.86	0.83	0.80	0.77	0.75
950	0.90	0.87	0.84	0.81	0.79
1,000	0.93	0.91	0.88	0.85	0.82
1,200	1.06	1.03	1.01	0.98	0.95
1,400	1.16	1.14	1.11	1.09	1.06
1,600	1.24	1.22	1.19	1.17	1.15
1,800	1.31	1.29	1.27	1.24	1.22
2,000	1.37	1.35	1.32	1.30	1.28
2,200	1.42	1.40	1.38	1.36	1.34
2,400	1.46	1.44	1.42	1.40	1.38
2,600	1.49	1.47	1.46	1.44	1.42
2,800	1.52	1.51	1.49	1.47	1.46
3,000	1.55	1.54	1.52	1.50	1.49
3,500	1.61	1.59	1.58	1.57	1.55
4,000	1.65	1.64	1.63	1.61	1.60
4,500	1.69	1.68	1.67	1.65	1.64
5,000	1.72	1.71	1.70	1.69	1.67
6,000	1.76	1.75	1.74	1.73	1.72
7,000	1.79	1.79	1.78	1.77	1.76
8,000	1.82	1.81	1.80	1.80	1.79
9,000	1.84	1.83	1.83	1.82	1.81
10,000	1.85	1.85	1.84	1.84	1.83
15,000	1.90	1.90	1.89	1.89	1.89
20,000	1.93	1.92	1.92	1.92	1.91
25,000	1.94	1.94	1.94	1.93	1.93

Note:For manifolded Stage II Balance Systems, the "Number of Affected Nozzles" shall be the total of all gasoline nozzles. For dedicated return configurations, the "Number of Affected Nozzles" shall be the total of those nozzles served by the tank being tested.

TABLE IB**STAGE II ASSIST SYSTEMS****PRESSURE DECAY LEAK RATE CRITERIA****INITIAL PRESSURE OF 2 INCHES OF H₂O****MINIMUM PRESSURE AFTER 5 MINUTES, INCHES OF H₂O**

<u>ULLAGE, GALLONS</u>	NUMBER OF AFFECTED NOZZLES				
	<u>01-06</u>	<u>07-12</u>	<u>13-18</u>	<u>19-24</u>	<u>> 24</u>
500	0.73	0.69	0.65	0.61	0.57
550	0.80	0.76	0.72	0.68	0.64
600	0.87	0.82	0.78	0.74	0.71
650	0.93	0.88	0.84	0.80	0.77
700	0.98	0.94	0.90	0.86	0.82
750	1.03	0.98	0.94	0.91	0.87
800	1.07	1.03	0.99	0.95	0.92
850	1.11	1.07	1.03	1.00	0.96
900	1.15	1.11	1.07	1.03	1.00
950	1.18	1.14	1.11	1.07	1.04
1,000	1.21	1.18	1.14	1.10	1.07
1,200	1.32	1.28	1.25	1.22	1.19
1,400	1.40	1.37	1.34	1.31	1.28
1,600	1.46	1.43	1.41	1.38	1.35
1,800	1.51	1.49	1.46	1.44	1.41
2,000	1.56	1.53	1.51	1.49	1.46
2,200	1.59	1.57	1.55	1.53	1.51
2,400	1.62	1.60	1.58	1.56	1.54
2,600	1.65	1.63	1.61	1.59	1.57
2,800	1.67	1.65	1.64	1.62	1.60
3,000	1.69	1.68	1.66	1.64	1.62
3,500	1.73	1.72	1.70	1.69	1.67
4,000	1.76	1.75	1.74	1.72	1.71
4,500	1.79	1.78	1.77	1.75	1.74
5,000	1.81	1.80	1.79	1.78	1.77
6,000	1.84	1.83	1.82	1.81	1.80
7,000	1.86	1.85	1.85	1.84	1.83
8,000	1.88	1.87	1.86	1.86	1.85
9,000	1.89	1.89	1.88	1.87	1.87
10,000	1.90	1.90	1.89	1.88	1.88
15,000	1.93	1.93	1.93	1.92	1.92
20,000	1.95	1.95	1.94	1.94	1.94
25,000	1.96	1.96	1.96	1.95	1.95

Note: For manifolded Stage II Assist Systems, the "Number of Affected Nozzles" shall be the total of all gasoline nozzles. For dedicated return configurations, the "Number of Affected Nozzles" shall be the total of those nozzles served by the tank being tested.

3745-21-10

Appendix B

1

DYNAMIC PRESSURE PERFORMANCE TEST

(taken from BAAQMD test procedure ST-27)

1. Applicability

1.1 This procedure is used to verify compliance with the applicable dynamic back pressure limits imposed on any Stage II vapor control system. The applicability of the following Alternate Methods is dependent upon the regulatory requirements imposed by the California Air Resources Board (CARB) Executive Order.

1.1.1 Alternate Method 1. This procedure is applicable if the dynamic back pressure standards are imposed from the nozzle to the gasoline storage tank, provided remote vapor check valves are not part of the Stage II system.

1.1.2 Alternate Method 2. This procedure is applicable if the dynamic back pressure standards are imposed from the Stage II riser to the gasoline storage tank, provided there is no vacuum-producing device located between the riser and tank.

1.1.3 Alternate Method 3. This procedure is applicable if the dynamic back pressure standards are imposed at the nozzle/vehicle interface during vehicle fueling.

1.1.4 Alternate Method 4. This procedure shall be conducted, in conjunction with the applicable of Alternate Methods 1, 2, or 3 if the Stage II system utilizes an incinerator.

1.2 Alternate Methods 1 and 2 shall be conducted with the Stage I vapor poppet **open**. Alternate Methods 3 and 4 shall be conducted with the poppet **closed**.

1.3 Other Alternate Methods may be used provided that written approval has been granted by the Ohio EPA, Division of Air Pollution Control. Such approval shall be based upon demonstrated equivalency of any proposed methodology.

2. Principle

2.1 Using Alternate Methods 1, 2, or 4, the dynamic back pressure during vehicle fueling is simulated by passing nitrogen through the Stage II vapor control system at specified rates. The resultant dynamic back pressure is measured using a pressure gauge, or equivalent device. Alternate Method 3 is a direct measurement of the pressure at the nozzle/fillpipe interface during gasoline dispensing. Liquid blockages in the vapor return lines are also detected using these Methods.

3. RANGE

3.1 The minimum and maximum dynamic back pressures that can be measured are dependent upon the range of the pressure gauges used. Required gauge ranges are as follows:

- | | | |
|--------------|----------------------------|---|
| 3.1.1 | Alternate Method 1. | 0-0.5 and 0-2 inches H ₂ O. |
| 3.1.2 | Alternate Method 2. | 0-0.25, 0-1, and 0-2 inches H ₂ O. |
| 3.1.3 | Alternate Method 3. | -1.0-+1.0 inches H ₂ O. |
| 3.1.4 | Alternate Method 4. | 0-0.5 and 0-1 inches H ₂ O. |

3.2 If mechanical pressure gauges are employed, the minimum diameter of the gauge face shall be four inches, and the minimum accuracy of the gauge shall be three percent of full scale.

3.3 If an electronic pressure measuring device is used, the full-scale range of the device shall not exceed 0-10 inches H₂O with a minimum accuracy of 0.5 percent of full scale. A 0-20 inches H₂O device may be used provided that the equivalent accuracy is not less than 0.25 percent of full-scale.

4. Interferences

4.1 Any leaks in the nozzle vapor path, vapor hose, or underground vapor return piping may result in erroneously low dynamic back pressure measurements.

4.2 For those Stage II systems possessing a design incompatible with this test procedure, testing shall be conducted in accordance with the procedures specified in the applicable CARB Executive Order.

5. Apparatus

5.1 Nitrogen High Pressure Cylinder with Pressure Regulator. Use a high pressure nitrogen cylinder capable of maintaining a pressure of 2000 psig and equipped with a compatible two-stage pressure regulator and a one psig relief valve. The nitrogen cylinder **must** be grounded and the one psig (maximum) relief valve **must** be present during the test.

- 5.2 Rotameter. Use a calibrated rotameter capable of accurately measuring nitrogen flowrate applicable for the imposed dynamic back pressure limits.
- 5.3 Pressure Gauges. Use differential pressure gauges, or equivalent, as specified in the applicable subsection of Section 3.1.
- 5.4 Automobile fillpipe. Use an automobile fillpipe, if applicable, known to be compatible with all bellows-equipped vapor control nozzles, and equipped with a pressure tap. See Figure 1.
- 5.5 Nitrogen. Use commercial grade nitrogen.
- 5.6 Hand Pump. Use a gasoline compatible hand pump, if applicable, to drain any gasoline from condensate pots.
- 5.7 Stopwatch. For Alternate Method 3, use a stopwatch, or equivalent, accurate to within 0.5 seconds.

6. Pre-test Procedures

- 6.1 **Alternate Method 1.** The following subsections are applicable for those Stage II systems where a limitation is imposed on the dynamic back pressure between the nozzle and the gasoline storage tank, provided that remote vapor check valves are not employed. For those Stage II systems which **do not** utilize a remote vapor check valve, assemble the apparatus as shown in Figure 1, ensuring that the riser shut-off valve on the test equipment is closed. If a Hirt Stage II system is used, the vacuum producing device shall be turned off during this test.
 - 6.1.1 Assemble the Dynamic Pressure Performance Test Assembly as shown in Figure 1.
 - 6.1.2 The test equipment **must** be leak-checked prior to use. Plug the nozzle end of the auto fillpipe and open the nitrogen cylinder. Adjust the flow meter control valve until a pressure of 50 percent of full scale is indicated on the high range pressure gauge. Close the nitrogen cylinder valve and any toggle valves. A pressure decay of less than 0.2 inches H₂O, in five minutes, is considered acceptable.
 - 6.1.3 Perform an initial visual examination for vapor leaks at the nozzles and hoses of the Stage II system to be tested. All leak sources shall be repaired or the component removed and replaced prior to testing.

6.1.4 The Stage I vapor poppet shall be propped open in such a manner that the valve is not damaged. This may be accomplished using a Dynamic Pressure Release Assembly as shown in Figure 2.

6.1.5 Pour a minimum of two (2) gallons of gasoline into each and every Stage II vapor return riser. This gasoline may be introduced into the Stage II riser in any appropriate manner. Alternatively, a minimum of twenty gallons of gasoline may be introduced into the Stage II riser furthest from the gasoline storage tank, provided that the riser is common to all products available at that dispenser. If product-specific risers are employed, a minimum of seven gallons, per product grade, may be introduced into the riser of each product which is furthest from the gasoline storage tank.

6.1.6 Allow fifteen (15) minutes for liquid in the vapor return piping to drain.

6.1.7 Completely drain any gasoline from the spout and bellows of each nozzle.

6.1.8 For those vapor piping configurations which utilize a condensate pot, drain the pot prior to testing.

6.2 Alternate Method 2.

6.2.1 Assemble the Capped "T" Assembly as shown in Figure 3.

6.2.2 Open the Stage I vapor poppet for the affected tank.

6.2.3 Pour a minimum of two (2) gallons of gasoline into each and every Stage II vapor return riser. This gasoline may be introduced into the Stage II riser in any appropriate manner.

6.2.4 Allow fifteen (15) minutes for liquid in the vapor return piping to drain.

6.2.5 For those vapor piping configurations which utilize a condensate pot, drain the pot prior to testing.

6.3 Alternate Method 3.

6.3.1 Assemble the Torus Pressure Test Assembly as shown in Figure 4.

6.3.2 The Stage I vapor poppet shall remain closed during this test.

6.4 Alternate Method 4.

- 6.4.1 Assemble the Vent Pipe Pressure Assembly as shown in Figure 5.
- 6.4.2 Carefully remove the vent pipe pressure/vacuum (P/V) valve.
- 6.4.3 Open the Stage I vapor poppet for the affected tank.
- 6.4.4 Insure that the collection unit of the Stage II system is turned off.

7. Testing

- 7.1 **Alternate Method 1.** Insert the nozzle into the fillpipe of the Dynamic Pressure Performance Test Unit as shown in Figure 1 below, ensuring that a tight seal at the fillpipe/nozzle interface is achieved.
 - 7.1.1 Connect the nitrogen supply to the test assembly.
 - 7.1.2 Open the nitrogen supply, set the delivery pressure to 5 psig, and use the flowmeter control valve to adjust the flowrate to lowest of the required nitrogen flowrates.
 - 7.1.3 A pulsating gauge needle indicates nitrogen passing through a liquid obstruction in the vapor return system. Close the flow meter control valve, drain the nozzle and hose assembly, and repeat the test. If this condition re-occurs, the cause of the liquid trap in the system must be corrected.

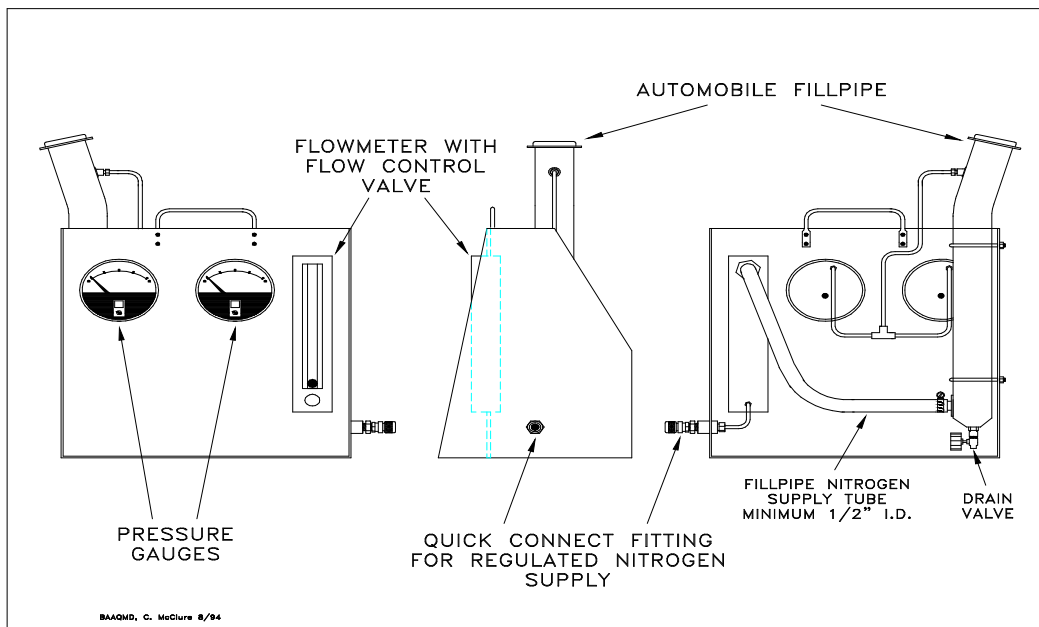
Figure 1**Dynamic Pressure Performance Test Assembly**

7.1.4 The following information shall be recorded on the field data sheet, as shown in Form 1:

- (a) Nozzle Number
- (b) Gauge needle action
- (c) Dynamic back pressure, inches H₂O

Specified nitrogen flowrates and associated maximum allowable Dynamic Backpressures are included in Form 1.

7.1.5 Repeat subsections 7.1.2 through 7.1.4 at all required nitrogen flowrates for each and every nozzle.

7.1.6 Close and replace the dust cover on the Stage I poppet.

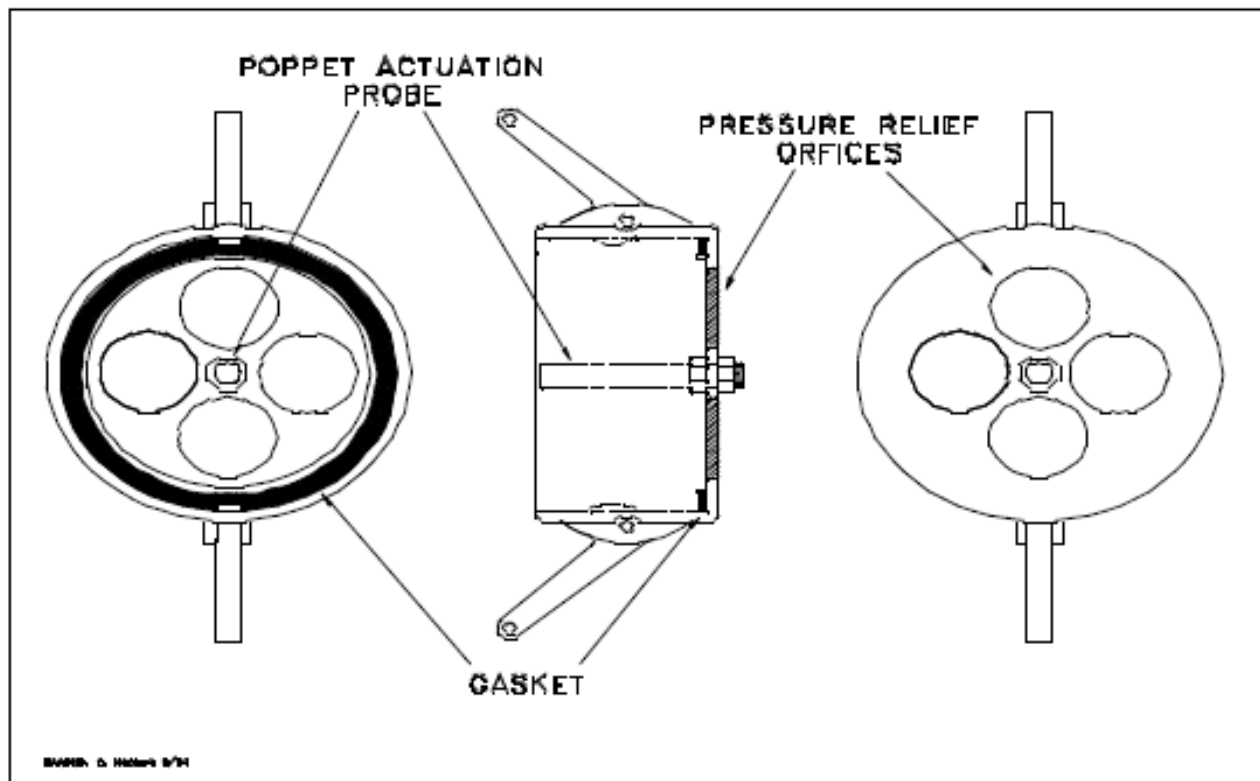
Figure 2**Dynamic Pressure Release Assembly**

7.2 Alternate Method 2. Those Stage II systems subject to regulatory limitations on the dynamic back pressure between the Stage II riser and gasoline storage tank shall be tested using this methodology.

7.2.1 Disconnect the Stage II riser and install the "T" assembly as shown in Figure 3 below.

Figure 3

Capped "T" Assembly

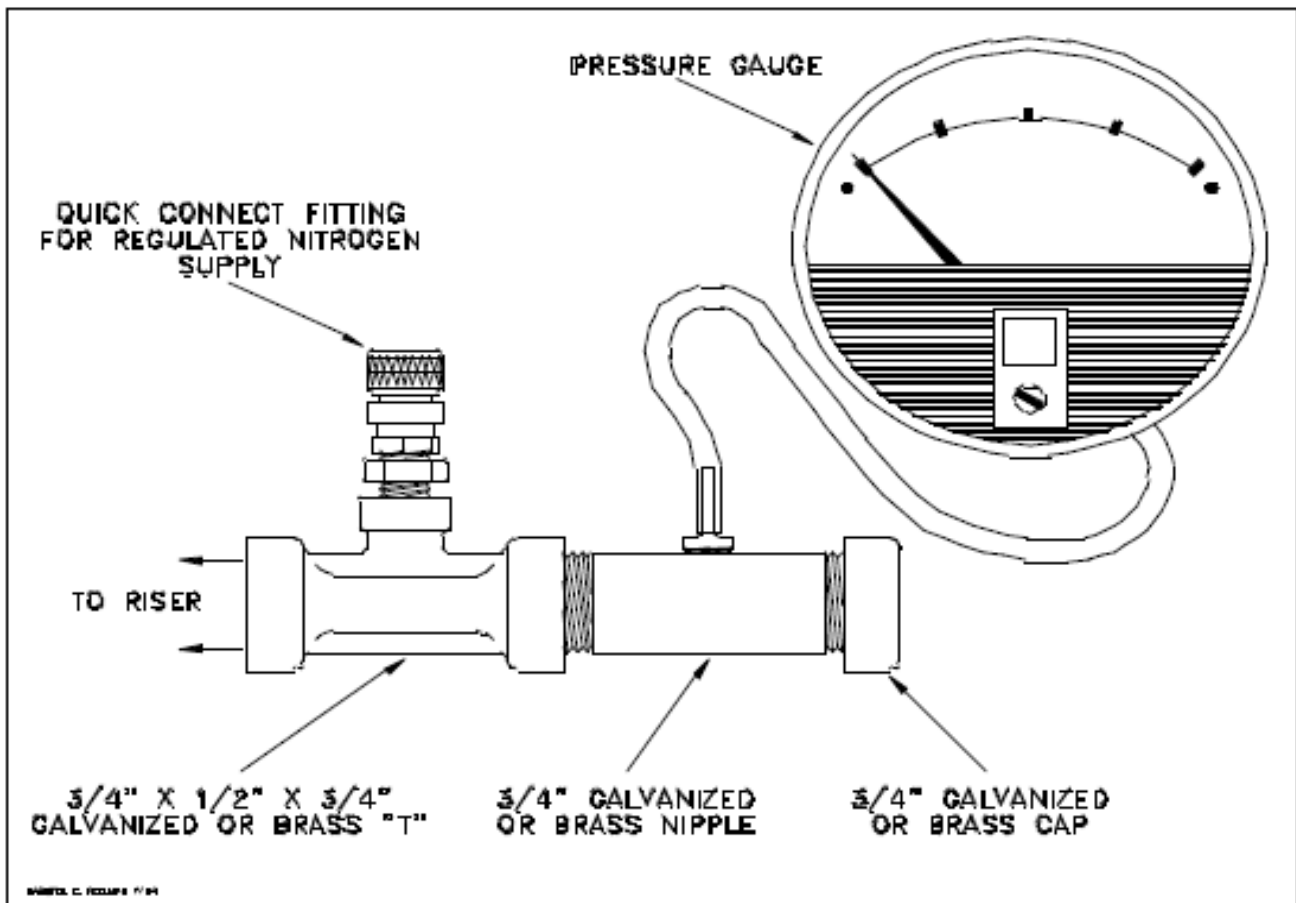

7.2.2 Connect the nitrogen supply to the "T" assembly.

7.2.3 Open the nitrogen supply, set the delivery pressure to 5 psig, and use the flowmeter control valve to adjust the flowrate to lowest of the required nitrogen flowrates.

7.2.4 A pulsating gauge needle indicates nitrogen passing through a liquid obstruction in the vapor return plumbing. If this occurs, the cause of the liquid trap must be corrected.

7.2.5 The following information shall be recorded on the field data sheet, as shown in Form 2:

- (a) Riser Number
- (b) Gauge needle action
- (c) Dynamic back pressure, inches H₂O

Specified nitrogen flowrates and associated maximum allowable Dynamic Backpressures are included in Form 2.

7.2.6 Repeat subsections 7.2.3 through 7.2.5 at all required nitrogen flowrates for each and every riser.

7.3 **Alternate Method 3.** Those bellows-equipped Stage II systems subject to regulatory limitations on the dynamic back pressure at the nozzle/fillpipe interface during gasoline dispensing shall use the following methodology.

7.3.1 Assemble the Torus Pressure Test Assembly (Donut) as shown in Figure 4 below

7.3.2 Insert the nozzle spout through the inner hole of the donut.

7.3.3 Insert and latch the nozzle in the vehicle fillpipe. Visually insure that a tight connection is made between the donut and fillpipe.

Figure 4

Torus Pressure Test Assembly

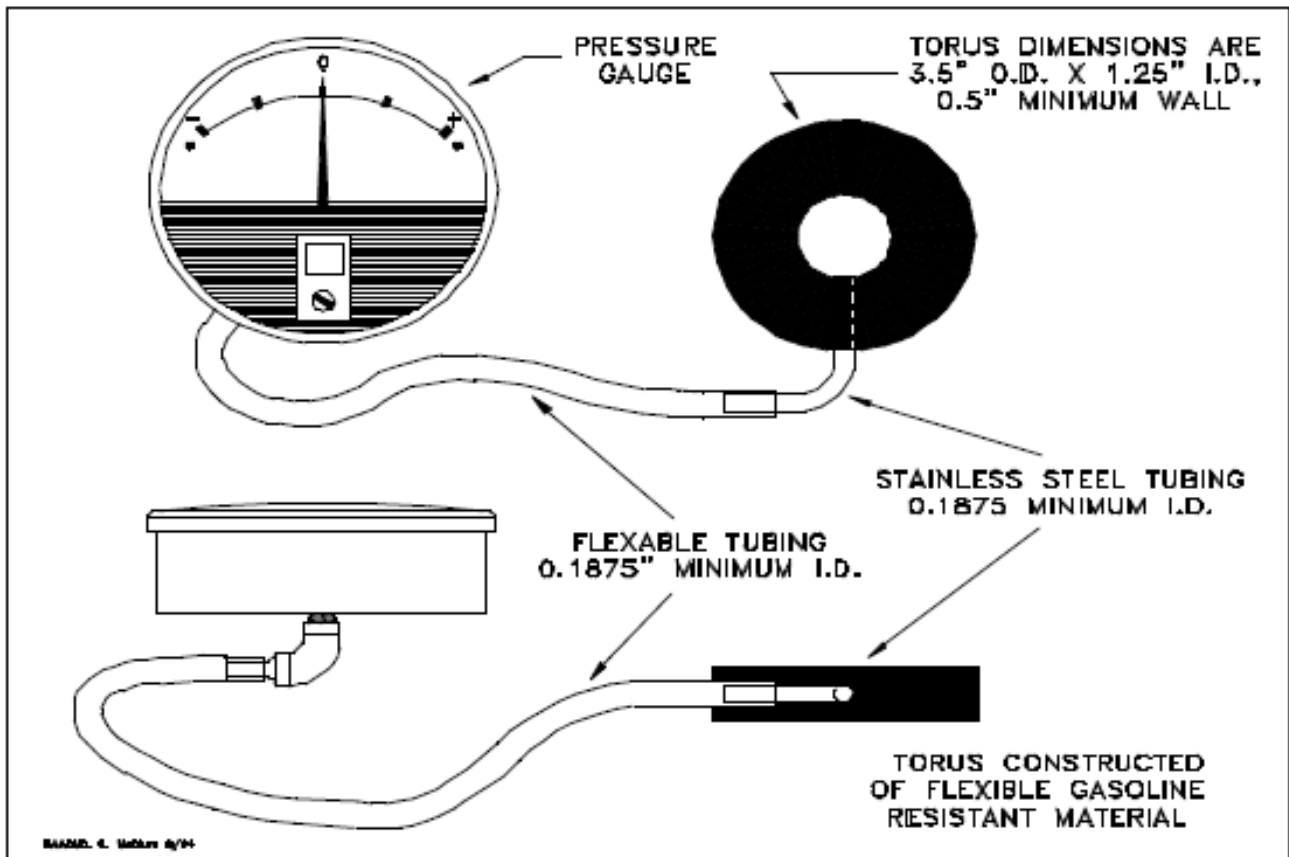

- 7.3.4** Activate the dispenser, set the nozzle hold-open latch on low, and after at least one gallon has been dispensed start the stopwatch. Dispense a minimum of four gallons of gasoline.

Use the stopwatch to accurately time the dispensing rate. Record the total gallons dispensed and calculate the flow rate in gallons per minute. The following data shall be recorded on the field data sheet as shown in Form 3:

- Nozzle number and gasoline grade
- Gallons dispensed during test
- Maximum dynamic back pressure, inches H₂O
- Minimum dynamic back pressure, inches H₂O
- The average dispensing rate, gallons per minute
- Allowable backpressure range specified in the Executive Order

7.3.5 This Alternate Method shall only be conducted with the Stage I vapor poppet closed, since gasoline is being dispensed during the test.

7.4 Alternate Method 4. Those Stage II systems which utilize an incinerator shall conduct this test in conjunction with the applicable of Alternate Method 1, 2, or 3. This procedure verifies proper drainage of gasoline from the base of the vent pipe to the gasoline storage tank.

7.4.1 After verifying compliance with the dynamic back pressure standards, pursuant to the applicable of Alternate Methods 1, 2, or 3, close the Stage I vapor poppet.

7.4.2 Remove the pressure/vacuum (P/V) valve from each vent pipe.

7.4.3 Carefully pour a minimum of five gallons of gasoline down each vent pipe.

7.4.4 Install the Vent Pipe Pressure Assembly as shown in Figure 5 below. Open the Stage I poppet on all affected tanks.

Figure 5

Vent Pipe Pressure Assembly

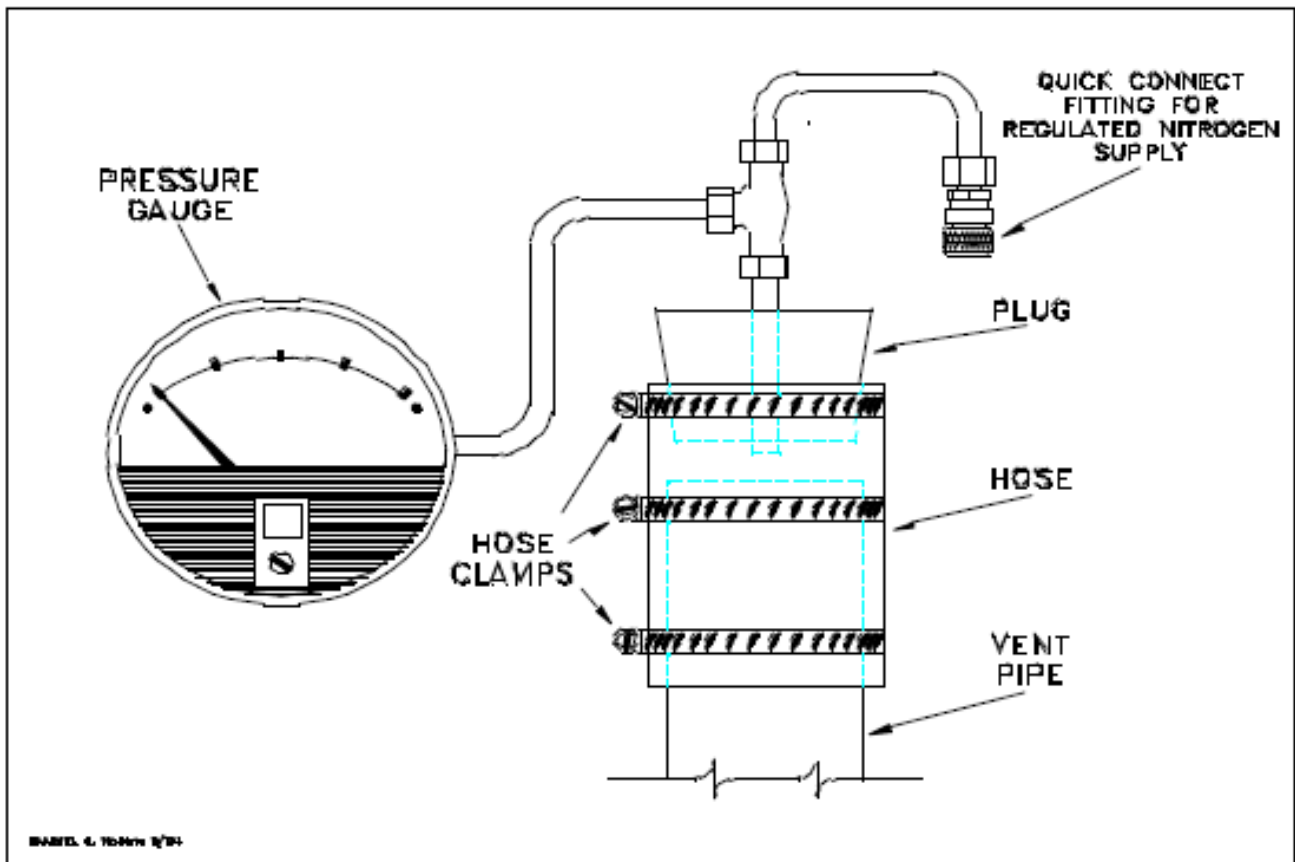

- 7.4.5 Connect the nitrogen supply to the Vent Pipe Pressure Assembly.
- 7.4.6 Open the nitrogen supply and adjust the flowrate to 60 CFH.
- 7.4.7 After a minimum of thirty seconds, record the dynamic back pressure.
- 7.4.8 A dynamic back pressure, from the top of the vent pipe to the storage tank, of less than 0.5 inches H₂O shall be considered acceptable.
- 7.4.9 Remove the Vent Pipe Pressure Assembly, carefully reinstall the P/V valve, and close the Stage I poppets.

8. Reporting

8.1 Results of the dynamic back pressure test shall be reported as shown below:

8.1.1 Alternate Method 1 Use Form 1

8.1.2 Alternate Method 2 Use Form 2

8.1.3 Alternate Method 3 Use Form 3

8.1.4 Alternate Method 4 Include on applicable of
Forms 1, 2, or 3

Form 1

Summary of Test Results Dynamic Pressure Performance

Date: _____ Time: _____ Application No. _____

GDF Name and address: _____

Quantity _____ (gallons) of gasoline introduced into Stage II (check one): Riser []
Bellows []

Stage II system type: (Manufacturer and Executive Order number) _____

Nozzle No.	40 CFH .16" MAX	60 CFH .35" MAX	80 CFH .62" MAX	PASS or FAIL	Nozzle No.	40 CFH .16" MAX	60 CFH .35" MAX	80 CFH .62" MAX	PASS or FAIL

Did gauge needle pulsate or peg at any flow rate during test? No [] **PASS**
Yes [] **FAIL**

Indicate location of storage tank(s), condensate pot(s), pump(s), and location where gasoline was introduced into the vapor return system on reverse side of this page:

Tests Conducted By: _____

Test Company: _____ Date of Tests: _____

Tests Witnessed By: _____

Form 3

Summary of Test Results Dynamic Pressure Performance

Date: _____ Time: _____ Application No. _____

GDF Name and address: _____

Stage II system type: (Manufacturer and Executive Order Number) _____

Nozzle No.	Gas Grade	Gallons Disp.	Max. B.P.	Min. B.P.	Disp Rate	Allowable B.P.	PASS OR FAIL

Indicate location of storage tank(s), condensate pot(s), pump(s), and location where gasoline was introduced into the vapor return system on reverse side of this page:

Tests Conducted By: _____

Test Company: _____ **Date of Tests:** _____

Tests Witnessed By: _____

APPENDIX C**STAGE II POST TEST INSPECTION FORM**

Facility Name:	Application #	
Address:	County:	
City, State, Zip		
DISPENSER AREA INSPECTION		
<input type="checkbox"/> All Vapor pipes under the dispenser are capped, plugged, or re-attached.		
<input type="checkbox"/> No leaks are present under dispenser, nor from hoses or nozzles.		
<input type="checkbox"/> All impact valves are open on all product lines.		
<input type="checkbox"/> All dispenser panels are correctly re-installed.		
<input type="checkbox"/> All lock-outs or "Out of Service" bags are removed from dispenser nozzles.		
<input type="checkbox"/> All tools, testing equipment, cones, and caution tape removed from dispenser area.		
TANK AREA INSPECTION		
<input type="checkbox"/> Isolation plugs are removed from vapor risers (if applicable).		
<input type="checkbox"/> All tank top components (plugs, caps, etc...) are reinstalled and secure.		
<input type="checkbox"/> "Drop out tank" free of product and functioning properly (with all caps replaced).		
<input type="checkbox"/> Submersible pit(s) free from leaks.		
<input type="checkbox"/> All tools, testing equipment, cones, and caution tape removed from tank area.		
<input type="checkbox"/> All lids and covers are properly replaced.		
Site Mgr. NAME:	Site Mgr. Signature:	Date:
Testers NAME:	Testers Signature:	Date:
Testing Company and Address:		

3745-21-11**Reasonably available control technology studies for non-CTG sources in ozone nonattainment areas.**

(A) The requirements of this rule apply to any facility which emits volatile organic compounds and meets both of the following conditions:

(1) The facility is located in Butler, Clermont, Cuyahoga, Geauga, Hamilton, Lake, Lorain, Medina, Portage, Summit, or Warren county.

(2) The facility emits, or has the potential to emit as defined in rule 3745-21-01 of the Administrative Code, one hundred tons or more of VOC emissions as of the effective date of this rule from sources which are not controlled by Ohio's CTG regulations in this chapter or by categorical non-CTG RACT contained in OAC rules 3745-21-12, 3745-21-14, 3745-21-16, 3745-21-21 and 3745-21-25.

[Comment: The requirements of this chapter may not be applicable to certain sources due to the applicability provisions or the specific exemptions and exclusions contained within that rule.]

[Comment: For the purposes of this rule, "controlled by" is not limited to physical pollution controls, but may include other types of controls such as VOC content limitations, operational limits or work practices.]

(B) The owner or operator of any facility subject to this rule shall conduct a detailed engineering study, performed by an engineering consulting firm or other person or persons experienced in the field of air pollution control, to determine the technical and economic feasibility of reducing the VOC emissions from the sources at the facility which are not by Ohio's CTG regulations in this chapter and to define RACT for the source, providing the following information:

(1) The complete facility name, Ohio EPA air program facility identification number, and address.

(2) The name, title, address and telephone number of the owner or operator's representative within the company who is the contact person for this facility regarding the engineering study and affected sources.

(3) The name, title, address and telephone number of the official who is responsible for approval of the engineering study.

(4) The standard industrial classification code and source classification code numbers which are applicable to the facility's operations.

(5) The following general information for each affected source:

- (a) Current Ohio EPA application number.
 - (b) Company identification and Ohio EPA emissions unit identification number.
 - (c) Source description.
 - (d) Month and year installed.
 - (e) Normal operating schedule (hours per day, days per week and weeks per year).
 - (f) Annual production rates for each of the three full calendar years preceding the effective date of this rule.
 - (g) Average and maximum daily production rates for each of the three full calendar years preceding the effective date of this rule.
 - (h) The type of control equipment employed and the date installed.
- (6) A plot plan which shows the general layout of the facility and the affected sources.
- (7) The following emissions data for each affected source:
- (a) Average daily VOC emissions (pounds per day of operation) based upon the highest average daily production rate for each of the three full calendar years preceding the effective date of this rule or any other year that may be representative of the highest average daily emissions.

[Comment: The average daily production rate for a calendar year may be calculated in the following manner:

Average daily production rate = [(total production rate during the calendar year) / (number of days production occurred during the calendar year)]

Repeat the calculation for each of the three calendar years preceding the effective date of this rule. The highest value of these three years is the representative value used to calculate the average daily VOC emissions per year.]
 - (b) Maximum daily VOC emissions (pounds per day of operation) based upon the highest maximum daily production rate for each of the three full

calendar years preceding the effective date of this rule or any year that may be more representative of the highest maximum daily emissions.

- (c) Annual VOC emissions (tons per year) based upon the highest annual production rate for each of the three full calendar years preceding the effective date of this rule or any year period that may be more representative of the annual production rate.
- (d) General composition of the VOC emissions.
- (e) If coating materials are used in the source, the company identification and formulation of each coating [VOC content (pounds per gallon of coating and pounds per gallon of coating, excluding water), water content (per cent by volume), solids content (per cent by volume), and exempt organics content (per cent by volume)].
- (f) Composition, density and quantity (pounds per day of operation and tons per year) of any clean-up solvents which were employed during the calendar year.
- (g) Documentation of the efficiency of the existing control equipment.
- (h) Documentation of any emissions testing which has been performed.
- (8) A detailed discussion of the technical feasibility of employing each of the following types of control measures for each affected source (or combination of sources):
 - (a) Carbon adsorber (with and without recovery of the organic compounds).
 - (b) Thermal incinerator (with and without heat recovery).
 - (c) Catalytic incinerator (with and without heat recovery).
 - (d) Condenser.
 - (e) Scrubber.
 - (f) Any other such RACT alternatives not listed in paragraph (B)(8) of this rule that may be applicable to an affected source, or as are proposed by the owner or operator.

A detailed engineering discussion is not required for those control measures which are not applicable to a particular source.

- (9) For each type of control measure that is determined to be technically feasible, an estimate of the control efficiency that can be achieved.
- (10) If coating materials are used in an affected source, a detailed discussion of the technical feasibility of converting to waterborne, high-solids or powder coatings to minimize or eliminate the VOC emissions (statements from several major coating suppliers should be obtained to document the conclusions).
- (11) A detailed discussion of the technical feasibility of modifying or replacing the source in order to minimize or eliminate the VOC emissions.
- (12) A quantification of the VOC emission reductions that could be achieved, at the production rates for the calendar year, by each control option that is determined to be technically feasible.
- (13) For each control option that is determined to be technically feasible, an estimate of the capital cost, annualized cost (including capital and operating costs), and the cost-effectiveness (annual dollars per ton of VOC removed annually).
- (14) A comparison and discussion of the advantages and disadvantages of control options that are determined to be technically feasible.
- (15) A recommended definition of RACT for the source, including one or more of the following:

 - (a) Enforceable production limitations.
 - (b) Emissions limitations.
 - (c) Control efficiencies.
 - (d) Operating requirements.
- (16) An expeditious schedule for implementing the recommended definition of RACT, including milestones for awarding contracts, initiating construction, completing construction, and performing emissions testing, if necessary, to demonstrate compliance with the approved definition of RACT.
- (17) Clean and detailed documentation of all calculations of the VOC emissions, including all assumptions made.
- (18) Capital and operating costs and cost-effectiveness estimates calculated in a manner consistent with the most recent edition of the "United States environmental protection agency air pollution control cost manual".

(C) If, within the five years prior to the effective date of this rule, the Ohio EPA has defined best available technology, pursuant to section 3704.01 of the Revised Code, for VOC emissions from a source which is subject to this rule, and the owner or operator is employing or has committed to employ the best available technology, the owner or operator may provide the following information to the director in satisfaction of paragraph (B) of this rule:

(1) All information required by paragraphs (B)(1), (B)(2), (B)(4), (B)(5) and (B)(7) of this rule.

(2) Copies of the documents and technical information that support the existing best available technology determination.

(3) The name, title, address and telephone number of the official who is responsible for the information submitted in accordance with paragraph (C) of this rule.

If upon review of this information, the director determines that the information does not or may not indicate that the definition of best available technology satisfies the requirements of this chapter, the director will so notify the owner or operator, and the owner or operator shall conduct a full RACT engineering study in accordance with paragraph (B) of this rule.

(D) For any facility having a potential to emit, as described in paragraph (A)(2) of this rule, in excess of one hundred tons of VOC as of the effective date of this rule, the detailed engineering study shall be submitted to the Ohio EPA, division of air pollution control (central office), by not later than one year after the effective date of this rule, and for any facility having a potential to emit in excess of one hundred tons of VOC during any calendar year after the effective date of this rule by not later than one year following the first such calendar year. The director may approve an alternate schedule for the submission of the detailed engineering study if additional time is required to ensure that the study is complete, comprehensive, and accurate.

(E) Any facility located in Butler, Clermont, Cuyahoga, Geauga, Hamilton, Lake, Lorain, Medina, Portage, Summit, or Warren county for which the director has established a site-specific definition of RACT in this chapter shall submit an updated RACT study to the Ohio environmental protection agency within one year of the effective date of this rule.

(F) Any definition of RACT and schedule of compliance for an affected source that are approved by the director will be submitted to and approved by the United States environmental protection agency as a revision of the Ohio state implementation plan.

Effective: 3/27/2022

Five Year Review (FYR) Dates: 11/29/2026

CERTIFIED ELECTRONICALLY

Certification

03/17/2022

Date

Promulgated Under: 119.03
Statutory Authority: 3704.03(E)
Rule Amplifies: 3704.03(A), 3704.03(E)

3745-21-15

Control of volatile organic compound emissions from wood furniture manufacturing operations.

[Comment: For dates and availability of non-regulatory government publications, publications of recognized organizations and associations, federal rules, and federal statutory provisions referenced in this rule, see paragraph (JJ) of rule 3745-21-01 of the Administrative Code titled "referenced materials."]

(A) Rule applicability.

(1) Except as otherwise provided in paragraph (A)(2) of this rule, this rule shall apply to any facility that meets both of the following criteria:

- (a) The facility is located in Ashtabula, Butler, Clermont, Cuyahoga, Geauga, Hamilton, Lake, Lorain, Medina, Portage, Summit, or Warren county; and
- (b) The facility has wood furniture manufacturing operations.

(2) ~~The following~~ Facilities are excluded from this rule if either of the following applies:

- (a) Any facility that has a potential to emit for VOC of less than 25.0 tons per year for all wood furniture manufacturing operations combined.
- (b) Any facility that uses no more than six hundred twenty-five gallons per month, for every month, or no more than seven thousand five hundred gallons per rolling twelve-month period, for every twelve-month period, of coating, adhesive, cleaning, and washoff materials, including thinners for such materials, for all wood furniture manufacturing operations combined. A rolling twelve-month period includes the previous twelve months of operation. The owner or operator of the facility shall maintain records of the total gallons of coating, adhesive, cleaning, and washoff materials, including thinners, used each month. The monthly records shall be retained by the owner or operator for a period of not less than five years and shall be made available to the director or any authorized representative of the director for review during normal business hours.

(B) Definitions.

The definitions applicable to this rule are contained in paragraph (X) of rule 3745-21-01 of the Administrative Code.

(C) Overall requirements for wood furniture manufacturing operations.

The owner or operator of a wood furniture manufacturing operation at a facility that is subject to this rule shall comply with paragraphs (D) to (N) of this rule.

(D) VOC emission limitations for finishing operations.

For any finishing operation, the owner or operator shall meet any one of the following paragraphs. If the owner or operator elects to use paragraph (D)(4) or (D)(5) of this rule, the owner or operator shall also meet paragraph (M) of this rule.

(1) VOC content limit for topcoats only.

(a) The VOC content of any topcoat shall not exceed 0.8 pound of VOC per pound of solids, as applied.

(b) There is no VOC content limit for sealers, stains, basecoats, and washcoats.

(2) VOC content limits for topcoats and sealers only.

(a) The VOC content of any topcoat shall not exceed 1.8 pounds of VOC per pound of solids, as applied, except for acid-cured alkyd amino conversion varnish topcoats.

(b) The VOC content of any acid-cured alkyd amino conversion varnish topcoat shall not exceed 2.0 pound of VOC per pound of solids, as applied.

(c) The VOC content of any sealer shall not exceed 1.9 pounds of VOC per pound of solids, as applied, except for acid-cured alkyd amino sealers.

(d) The VOC content of any acid-cured alkyd amino sealer shall not exceed 2.3 pound of VOC per pound of solids, as applied.

(e) There is no VOC content limit for stains, basecoats, and washcoats.

(3) VOC emission control system for topcoats or sealers.

In lieu of a VOC content limit for any topcoat subject to paragraph (D)(1) or (D)(2) of this rule or any sealer subject to paragraph (D)(2) of this rule, a VOC emission control system shall be used that achieves for each topcoat or sealer employed and designated for control, an overall reduction of VOC emissions that is equal to or greater than the required overall control efficiency determined in accordance with paragraph (I)(6) of this rule. Also, if the VOC emission control system includes a thermal or catalytic oxidizer, the control efficiency of the thermal or catalytic oxidizer for VOC emissions shall be at least ninety per cent by weight.

(4) Daily VOC emissions limit for topcoats only.

Each topcoat employed in any day shall be subject to either a daily VOC emissions limit or a VOC content limit, as specified in paragraphs (D)(4)(a) and (D)(4)(b) of this rule. There is no VOC limit for sealers, stains, basecoats, and washcoats.

- (a) The daily actual VOC emissions (E_{day}) shall not exceed the daily VOC emissions limit (L_{day}) in which " E_{day} " and " L_{day} " are calculated for topcoats as follows:

$$E_{\text{day}} = \sum_{i=1}^n (AT_i)(CT_i)(1 - F_i)$$

$$L_{\text{day}} = (0.90) \sum_{i=1}^n (AT_i)(LT_i)$$

where:

AT_i = amount of solids of topcoat "i" used for the day, in pounds of solids.

CT_i = VOC content of topcoat "i" in pounds of VOC per pound of solids, as applied.

F_i = fraction by weight of VOC emissions from topcoat "i" reduced or prevented from being emitted by a VOC emission control system.

LT_i = emission limit for topcoat "i" expressed as 0.8 pound of VOC per pound of solids, as applied. However, for a facility located in Butler, Clermont, Hamilton, or Warren county, if topcoat "i" is employed at the facility as of May 27, 2005 and if the VOC content of topcoat "i" is less than the previously stated emissions limit, then the facility shall use the actual VOC content of topcoat "i" as of May 27, 2005 as the emissions limit for topcoat "i". Likewise, for a facility located in Ashtabula, Cuyahoga, Geauga, Lake, Lorain, Medina, Portage, or Summit county, if topcoat "i" is employed at the facility as of August 25, 2008 and if the VOC content of topcoat "i" is less than the previously stated emissions limit, then the facility shall use the actual VOC content of topcoat "i" as of August 25, 2008 as the emissions limit for topcoat "i".

i = subscript denoting a specific topcoat selected by the owner or operator for inclusion in the daily VOC emissions limit.

n = total number of topcoats selected by the owner or operator for inclusion in the daily VOC emissions limit

- (b) For any topcoat not selected by the owner or operator for inclusion in the daily VOC emissions limit, the VOC content of the topcoat shall not exceed 0.8 pound of VOC per pound of solids.

(5) Daily VOC emissions limit for topcoats, sealers, and other finishing materials.

Each topcoat and sealer employed in any day shall be subject to either a daily VOC emissions limit or a VOC content limit, as specified in paragraphs (D)(5)(a) and (D)(5)(b) of this rule. Stains, basecoats, and washcoats can be included in the daily VOC emissions limit. There is no VOC limit for stains, basecoats, and washcoats that are not included in the alternative daily VOC emissions limit.

- (a) The daily actual VOC emissions (E_{day}) shall not exceed the daily VOC emissions limit (L_{day}) in which " E_{day} " and " L_{day} " are calculated for finishing materials as follows:

$$E_{\text{day}} = \sum_{i=1}^n (A_i)(C_i)(1 - F_i)$$

$$L_{\text{day}} = (0.90) \sum_{i=1}^n (A_i)(L_i)$$

where:

A_i = amount of finishing material "i" employed for the day, expressed in pounds of solids if a topcoat, sealer, washcoat, or basecoat; or in gallons if a stain.

C_i = VOC content of finishing material "i" employed for the day, expressed in pounds of VOC per gallon of solids, as applied, if a topcoat, sealer, washcoat, or basecoat; or in pounds of VOC per gallon, as applied, if a stain.

F_i = fraction by weight of VOC emissions from finishing material "i" reduced or prevented from being emitted by a VOC emission control system.

L_i = emissions limit for finishing material "i" based of the type of finishing material as follows: 1.8 pounds of VOC per gallon of solids for a topcoat; 1.9 pounds of VOC per gallon of solids for a sealer; 9.0 pounds of VOC per gallon of solids for a washcoat; 1.2 pound of VOC per gallon of solids for a basecoat; and 0.791 pounds of VOC per gallon of coating

for a stain. However, for a facility located in Butler, Clermont, Hamilton, or Warren county, if finishing material "i" is employed at the facility as of May 27, 2005 and if the VOC content of finishing material "i" is less than the previously stated emissions limit, then the facility shall use the actual VOC content of finishing material "i" as of May 27, 2005 as the emissions limit for finishing material "i". Likewise, for a facility located in Ashtabula, Cuyahoga, Geauga, Lake, Lorain, Medina, Portage, or Summit county, if finishing material "i" is employed at the facility as of August 25, 2008 and if the VOC content of finishing material "i" is less than the previously stated emissions limit, then the facility shall use the actual VOC content of finishing material "i" as of August 25, 2008 as the emissions limit for finishing material "i".

i = subscript denoting a specific finishing material selected by the owner or operator for inclusion in the alternative daily VOC emissions limit.

n = total number of finishing material selected by the owner or operator for inclusion in the alternative daily VOC emissions limit.

(b) For any topcoat or sealer not selected by the owner or operator for inclusion in the daily VOC emissions limit, the VOC content limit shall be the following:

(i) The VOC content of any topcoat shall not exceed 1.8 pounds of VOC per pound of solids, except for acid-cured alkyd amino conversion varnish topcoats.

(ii) The VOC content of any acid-cured alkyd amino conversion varnish topcoat shall not exceed 2.0 pound of VOC per pound of solids.

(iii) The VOC content of any sealer shall not exceed 1.9 pounds of VOC per pound of solids, except for acid-cured alkyd amino sealers.

(iv) The VOC content of any acid-cured alkyd amino sealer shall not exceed 2.3 pounds of VOC per pound of solids.

(E) VOC content limit for strippable spray booth materials.

The VOC content of any strippable spray booth material employed for wood furniture manufacturing operations shall not exceed 0.8 pound of VOC per pound of solids, as applied.

(F) Work practices.

The owner or operator of a facility subject to this rule shall prepare and maintain a written work practice implementation plan that defines environmentally desirable work practices for each wood furniture manufacturing operation and addresses each of the work practices contained in paragraphs (b) to (d) and (f) to (k) of 40 CFR 63.803 and the following:

- (1) For any terms pertaining to the work practices that are not defined under paragraph (B) of this rule, the definitions under 40 CFR 63.801 shall be the used.
- (2) The wording "Administrator (or delegated State, local, or Tribal authority)" is replaced by the wording "Ohio EPA district office or local air agency."
- (3) The wording "organic HAP solvent" is replaced by the wording "VOC solvent."
- (4) The plan shall be developed no more than sixty days after the compliance date.

(G) Compliance dates.

- (1) Except where otherwise specified within this rule, any owner or operator of a facility that is subject to this rule shall comply with this rule by no later than the following dates:
 - (a) For a facility located in Butler, Clermont, Hamilton, or Warren county for which installation commenced before May 27, 2005, the compliance date of any wood furniture manufacturing operation within the facility is either May 27, 2006 or the date of initial startup of the wood furniture manufacturing operation, whichever is later.
 - (b) For a facility located in Butler, Clermont, Hamilton, or Warren county for which installation commenced on or after May 27, 2005, the compliance date of any wood furniture manufacturing operation within the facility is the date of initial startup of the wood furniture manufacturing operation.
 - (c) For a facility located in Ashtabula, Cuyahoga, Geauga, Lake, Lorain, Medina, Portage, or Summit county, for which installation commenced before August 25, 2008, the compliance date of any wood furniture manufacturing operation within the facility is August 25, 2009 or the date of initial startup of the wood furniture manufacturing operation, whichever is later.
 - (d) For a facility located in Ashtabula, Cuyahoga, Geauga, Lake, Lorain, Medina, Portage, or Summit county for which installation commenced on or after August 25, 2008, the compliance date of any wood furniture

manufacturing operation within the facility is the date of initial startup of the wood furniture manufacturing operation.

- (2) For a VOC emission control system that is used for a finishing operation to comply with paragraph (D)(3), (D)(4), or (D)(5) of this rule, the owner or operator shall demonstrate the overall control efficiency of the VOC emission control system by testing the finishing operation and the VOC emission control system in accordance with paragraph (J) of this rule within ninety days after the finishing operation's compliance date.
- (3) Additional testing of the finishing operation and the VOC emission control system in accordance with paragraph (J) of this rule may be required by the director to ensure continued compliance.

(H) Monitoring requirements for a VOC emission control system.

- (1) For any incinerator used to comply with paragraph (D) of this rule, the owner or operator shall install, calibrate, maintain, and operate according to manufacturer's specifications, a temperature monitoring device equipped with a continuous recorder. The temperature monitoring device shall be located as follows:
 - (a) Where a thermal incinerator is used, the temperature monitoring device shall be located in the firebox or in the duct immediately downstream of the firebox in a position before any substantial heat exchange occurs.
 - (b) Where a catalytic incinerator is used, one of the following:
 - (i) Temperature monitoring devices shall be installed in the gas stream immediately before (upstream) and after (downstream) the catalyst bed.
 - (ii) If an owner or operator elects to implement an inspection and maintenance plan for the catalytic incinerator that meets paragraph (J)(2)(b)(iv) of this rule, the temperature monitoring device shall be located upstream of the catalyst bed only.
- (2) For any regenerative carbon adsorber used to comply with paragraph (D) of this rule, the owner or operator shall install, calibrate, maintain and operate according to manufacturer's specifications the following monitoring devices:
 - (a) An integrating regeneration steam flow monitoring device, having an accuracy of plus or minus ten per cent or better, shall be employed for

recording the total regeneration steam mass or volumetric flow for each regeneration cycle.

- (b) A carbon bed temperature monitoring device shall be employed for recording the carbon bed temperature after each regeneration and within fifteen minutes of completing any cooling cycle.
- (3) For any concentrator, such as a zeolite wheel or rotary carbon bed concentrator, used to comply with paragraph (D) of this rule, the owner or operator shall install, calibrate, maintain, and operate according to manufacturer's specifications the following monitoring devices equipped with continuous recorders:
- (a) A temperature monitoring device for the desorption gas stream.
 - (b) A pressure monitoring device to measure pressure drop across the zeolite wheel or rotary carbon bed with an accuracy of at least 0.5 inches of water column or five per cent of the measured value, whichever is larger.
- (4) Where a control device other than an incinerator, regenerative carbon adsorber, or concentrator is used to comply with paragraph (D) of this rule, or as an alternative to the monitoring device specified in paragraphs (H)(1) to (H)(3) of this rule, the owner or operator shall install, calibrate, maintain, and operate, according to manufacturer's specifications, an organic monitoring device equipped with a continuous recorder for measuring the concentration level at the outlet of the control device.
- (5) For any capture system that is part of a VOC emissions control used to comply with paragraph (D) of this rule and that is a permanent total enclosure, the owner or operator shall install, calibrate, maintain, and operate, according to manufacturer's specifications, either one of the following:
- (a) A pressure monitoring device equipped with a continuous recorder to measure pressure drop across the enclosure with an accuracy of at least 0.5 inch of water column or five per cent of the measured value, whichever is larger.
 - (b) A monitoring device equipped with a continuous recorder to measure the facial velocity of air through any natural draft opening into the enclosure.
- (6) For any capture system that is part of a VOC emissions control used to comply with paragraph (D) of this rule and that is not a permanent total enclosure, the owner or operator shall install, calibrate, maintain, and operate, according to manufacturer's specifications, either one of the following:

- (a) A pressure monitoring device equipped with a continuous recorder to measure the static pressure for each capture device with an accuracy of at least 0.5 inch of water column or five per cent of the measured value, whichever is larger.
- (b) A flow rate monitoring device equipped with a continuous recorder to measure the flow in the duct from each capture device in the capture system to the control device with an accuracy of at least ten per cent of the flow.

(7) Capture system bypass line.

For any capture system that is part of a VOC emissions control used to comply with paragraph (D) of this rule and that contains bypass lines which could divert flow (i.e., VOC emissions) away from the control device to the atmosphere, the owner or operator shall for each bypass line meet any one of the following:

- (a) (Flow control position indicator) The owner or operator shall install, calibrate, maintain, and operate, according to manufacturer's specifications, a flow control position indicator that takes a reading at least once every fifteen minutes and provides a record indicating whether the emissions are directed to the control device or diverted from the control device. The flow control position indicator shall be installed at the entrance to any bypass line that could divert the emissions away from the control device to the atmosphere.
- (b) (Car-seal or lock-n-key) The owner or operator shall secure the bypass line valve in the nondiverting position with a car-seal or a lock-and-key type configuration. The owner or operator shall perform a visual inspection of the seal or closure mechanism at least once every month to ensure that the valve is maintained in the non-diverting position and the emissions are not diverted away from the add-on control device to the atmosphere.
- (c) (Valve closure monitoring) The owner or operator shall employ a valve closure monitoring system that ensures any bypass line valve is in the closed (nondiverting) position through monitoring of valve position at least once every fifteen minutes. The owner or operator shall inspect the monitoring system at least once every month to verify that the monitor will indicate valve position.
- (d) (Automatic shutdown system) The owner or operator shall employ an automatic shutdown system in which the finishing operation is stopped when flow is diverted by the bypass line away from the control device

to the atmosphere when the finishing operation is running. The owner or operator shall inspect the automatic shutdown system at least once every month to verify that it will detect diversions of flow and shut down the finishing operation.

- (e) (Flow direction indicator) The owner or operator shall install, calibrate, maintain, and operate, according to the manufacturer's specifications, a flow direction indicator that takes a reading at least once every fifteen minutes and provides a record indicating whether the emissions are directed to the control device or diverted from the control device. Each time the flow direction changes, the next reading of the time of occurrence and flow direction shall be recorded. The flow direction indicator shall be installed in each bypass line or air makeup supply line that could divert the VOC emissions away from the control device to the atmosphere.
- (8) (Alternative control device monitoring) An owner or operator of a control device that is part of a VOC emission control system used to comply with paragraph (D) of this rule may request approval to employ monitoring devices and monitoring parameters other than those listed in paragraphs (H)(1) to (H)(4) of this rule. The request shall be submitted in accordance with paragraph (H)(10) of this rule.
- (9) (Alternative capture system monitoring or bypass line monitoring) An owner or operator of a capture system that is part of a VOC emission control system used to comply with paragraph (D) of this rule may request approval to employ monitoring devices and monitoring parameters other than those listed in paragraphs (H)(5) to (H)(7) of this rule. The request shall be submitted in accordance with paragraph (H)(10) of this rule.
- (10) Approval of alternative monitoring devices and parameters.
 - (a) The owner or operator who has been directed by any paragraph of this rule to request approval to employ monitoring devices and parameters other than required by this rule shall submit within an application for a permit or modification of a permit, or by other means provided by the appropriate Ohio EPA district office or local air agency, the following information:
 - (i) A description of the parameter to be monitored to ensure the capture system or control device is operated in conformance with its design and achieves the specified emission limit, per cent reduction, or nominal efficiency, and an explanation of the criteria used to select the parameter.

- (ii) A description of the methods and procedures that will be used to demonstrate that the parameter indicates proper operation of the capture system or control device being monitored, the schedule for this demonstration, and a statement that the owner or operator will establish an operating limit (operating parameter value) for the monitored parameter as part of the initial compliance status report required in paragraph (L)(2) of this rule.
 - (iii) The frequency and content of monitoring, recording, and reporting if monitoring and recording is not continuous, or if reports of operating values when the monitored parameter value is outside the operating limit established in the permit or initial compliance report will not be included in semiannual compliance status reports as specified in paragraph (L)(3) of this rule. The rationale for the proposed monitoring, recording, and reporting system shall be included.
 - (b) If the monitoring device and parameter are approved by the director, the monitoring device and parameter, including associated records and semiannual reporting, shall be specified in the terms and conditions of a permit or order issued by the director. If required by USEPA, any director-approved alternative monitoring device or monitoring parameter shall be submitted to USEPA for approval as a revision of the state implementation plan.
- (11) While operating a VOC emission control system for controlling emissions from a finishing operation, the owner or operator shall not operate any capture or control device within the VOC emission control system at a three-hour block average value greater than or less than (as appropriate) the operating limits (operating parameter values) established during the most recent compliance test that demonstrated compliance, except during periods of startup, shutdown, and malfunction.
- (12) The owner or operator shall inspect the VOC emission control system and monitoring equipment to assure that the VOC emission control system is operating properly, and that no leaks or malfunctions have occurred or are occurring. The inspections shall be made at the frequency defined by the equipment manufacturer, or as otherwise appropriate for each VOC emission control system and monitoring equipment, but not less than monthly.
- (I) Procedures for the VOC content and solids content of a coating, the VOC content for continuous coaters, and the determination of required overall control efficiency for controlled topcoats and sealers.

- (1) The VOC content and solids content of a coating (finishing material or a strippable spray booth material) shall be determined by the owner or operator in accordance with paragraph (B) of rule 3745-21-10 of the Administrative Code, wherein formulation data or USEPA method 24 procedures (which include various ASTM measurement methods) may be employed.
- (2) For a finishing material containing styrene, the VOC content and VOC emissions associated with styrene shall be based on an estimate of the unreacted styrene, which shall be calculated by multiplying the amount of styrene monomer in the finishing material, when applied, by a factor of 0.16.
- (3) For a finishing material containing formaldehyde, the VOC content and VOC emissions associated with formaldehyde shall be based on the amount of free formaldehyde present in the finishing material when applied. The free formaldehyde content shall be determined in accordance with ASTM D1979-97, D5910-12, D6191-97(2008)e1, or D6902-04(2011).
- (4) A certified product data sheet that provides data on VOC content and solids content shall be used by the owner or operator provided that any data based on a measurement method shall be a measurement method that meets paragraph (I) of this rule.
- (5) VOC content for continuous coaters.

The as-applied VOC content of a finishing material that is applied by a continuous coater shall be determined by one of the following procedures:

- (a) (VOC content for a continuous coater) The as-applied VOC content of a finishing material that is applied by a continuous coater shall be determined by the VOC content of the finishing material in the reservoir and the VOC content as calculated from records.
- (b) (VOC content and viscosity measurements for a continuous coater) The as-applied VOC content of a finishing material that is applied by a continuous coater shall be determined by the VOC content of the finishing material in the reservoir, maintaining a viscosity of the finishing material in the reservoir that is no less than the viscosity of the initial finishing material by monitoring the viscosity with a viscosity meter or by testing the viscosity of the initial finishing material and retesting the material in the reservoir each time solvent is added, and maintaining records of solvent additions. In order to use this procedure, the owner or operator shall provide data that demonstrates the correlation between viscosity of

the finishing material and the VOC content of the finishing material in the reservoir.

- (c) (Rolling thirty-day average VOC content for a dip coater) The as-applied VOC content of a finishing material that is applied by a dip coater shall be determined by a rolling thirty-day average of the VOC content of the finishing material and thinner added to the reservoir of the dip coater. The rolling thirty-day average VOC content (C_{30}), expressed in pounds of VOC per pound of solids, as applied, shall be calculated for each day of operation of the dip coater as follows:

$$C_{30} = \frac{\sum_{i=1}^n (A_{i,30})(C_{i, \text{VOC}})}{\sum_{i=1}^n (A_{i,30})(C_{i, \text{solids}})}$$

where:

$A_{i,30}$ = amount of material "i" added to the reservoir of the dip coater during a thirty-day period consisting of the day of operation of the continuous coater plus the past twenty-nine calendar days, expressed in gallons.

$C_{i,\text{VOC}}$ = VOC content of material "i", expressed in pounds of VOC per gallon.

$C_{i,\text{solids}}$ = solids content of material "i", expressed in pounds of solids per gallon.

i = subscript denoting a specific material (finishing material or thinner) added to the reservoir of the dip coater during the thirty-day period.

n = total number of materials (finishing materials and thinners) added to the reservoir of the dip coater during the thirty-day period.

(6) Determination of required overall control efficiency for controlled topcoats and sealers.

For a VOC emission control system that is used to comply with paragraph (D)(3) of this rule, the overall reduction of VOC emissions, that is, the required overall control efficiency (R), expressed in per cent by weight, shall be determined as follows for each topcoat and sealer designated for control:

$$R = [(C - L)/C](100)$$

where:

C = the VOC content of the topcoat or sealer designated for control, in pounds of VOC per pound of solids, as applied.

L = the VOC content limit under paragraph (D)(1) or (D)(2) of this rule for the topcoat or sealer designated for control, in pounds of VOC per pound of solids, as applied.

(J) Compliance tests for VOC emission control systems.

(1) For a VOC emission control system used to comply with paragraph (D) of this rule, the owner or operator shall conduct an initial compliance test to determine the capture efficiency of the capture system, the control efficiency of the control device (or each control device if a combination of control devices), and the overall control efficiency of the VOC emission control system in accordance with paragraph (C) or rule 3745-21-10 of the Administrative Code wherein USEPA method 25 or 25A shall be used for determining the concentration of VOC in a gas stream.

(2) During the compliance test described in paragraphs (J)(1) of this rule that demonstrates compliance, the owner or operator shall establish the operating limits (operating parameter values) for the monitoring devices required under paragraph (H) of this rule as follows:

(a) If the control device is a thermal oxidizer, establish the operating limit as follows:

- (i) Monitor and record the combustion temperature either in the firebox of the thermal oxidizer or immediately downstream of the firebox before any substantial heat exchange occurs at least once every fifteen minutes during each of the three runs of the compliance test.
 - (ii) Calculate and record the average combustion temperature maintained during the compliance test. This average combustion temperature is the minimum operating limit for the thermal oxidizer.
- (b) If the control device is a catalytic oxidizer, establish the operating limits according to either paragraphs (J)(2)(b)(i) and (J)(2)(b)(ii) or paragraphs (J)(2)(b)(iii) and (J)(2)(b)(iv) of this rule.
- (i) Monitor and record the temperature just before the catalyst bed and the temperature difference across the catalyst bed at least once every fifteen minutes during each of the three test runs comprising a compliance test.
 - (ii) Calculate and record the average temperature just before the catalyst bed and the average temperature difference across the catalyst bed maintained during the compliance test. These are the minimum operating limits for the catalytic oxidizer.
 - (iii) Monitor and record the temperature just before the catalyst bed at least once every fifteen minutes during each of the three test runs of the compliance test. Use this recorded temperature data to calculate and record the average temperature before the catalyst bed during the performance test. This is the minimum operating limit for the catalytic oxidizer.
 - (iv) Develop and implement an inspection and maintenance plan for the catalytic oxidizer for which the owner or operator elects to monitor according to paragraph (J)(2)(b)(iii) of this rule. At a minimum, the plan shall address, the following:
 - (a) Conduct an annual sampling and analysis of the catalyst activity (i.e., conversion efficiency) following the manufacturer's or catalyst supplier's recommended procedures. If problems are found during the catalyst activity test, the owner or operator shall replace the catalyst bed or take other corrective action consistent with the manufacturer's recommendations.

- (b) Conduct monthly external inspection of the catalytic oxidizer system, including the burner assembly and fuel supply lines for problems and, as necessary, adjust the equipment to assure proper air-to-fuel mixtures.
- (c) Conduct annual internal inspection of the catalyst bed to check for channeling, abrasion, and settling. If problems are found during the annual internal inspection of the catalyst, the owner or operator shall replace the catalyst bed or take other corrective action consistent with the manufacturer's recommendations. If the catalyst bed is replaced and is not of like or better kind and quality as the old catalyst, then the owner or operator shall conduct a new compliance test to determine the control efficiency of the catalytic oxidizer according to paragraph (I)(1) of this rule. If a catalyst bed is replaced and the replacement catalyst is of like or better kind and quality as the old catalyst, then a new compliance test to determine the control efficiency of the catalytic oxidizer is not required and the previously established operating limits for that catalytic oxidizer may be used.
- (c) If the control device is a regenerative carbon adsorber, establish the operating limits as follows:

 - (i) Monitor and record the total regeneration desorbing gas (e.g., steam or nitrogen) mass flow for each regeneration cycle, and the carbon bed temperature after each carbon bed regeneration and cooling cycle for the regeneration cycle either immediately preceding or immediately following the compliance test.
 - (ii) The operating limits for the regenerative carbon adsorber are the minimum total desorbing gas mass flow recorded during the regeneration cycle and the maximum carbon bed temperature recorded after the cooling cycle.
- (d) If the control device includes a concentrator, establish operating limits for the concentrator as follows:

 - (i) Monitor and record the desorption concentrate stream gas temperature at least once every fifteen minutes during each of the three runs of the compliance test.

- (ii) Use the data collected during the compliance test to calculate and record the average temperature. This is the minimum operating limit for the desorption concentrate gas stream temperature.
 - (iii) Monitor and record the pressure drop of the dilute stream across the concentrator at least once every fifteen minutes during each of the three runs of the performance test.
 - (iv) Use the data collected during the compliance test to calculate and record the average pressure drop. This is the minimum operating limit for the pressure drop of the dilute stream across the concentrator.
- (e) If the capture system is a permanent total enclosure, the operating limit is either one of the following, based on the criteria of a permanent total enclosure:
- (i) The pressure drop across the enclosure shall be at least 0.007 inch of water.
 - (ii) The average facial velocity of air through all natural draft openings shall be at least two hundred feet per minute.
- (f) If the capture system is a not a permanent total enclosure, establish an operating limit for each separate capture device in the capture system as follows:
- (i) Monitor and record either the gas volumetric flow rate or the duct static pressure for each separate capture device in the emission capture system at least once every fifteen minutes during each of the three test runs of the compliance test for capture efficiency at a point in the duct between the capture device and the control device inlet.
 - (ii) Calculate and record the average gas volumetric flow rate or average duct static pressure for the three test runs for each capture device. This average gas volumetric flow rate or average duct static pressure is the minimum operating limit for that specific capture device.

(K) Recordkeeping.

- (1) (General) The following records shall be retained by the owner or operator for a period of not less than five years and shall be made available to the director or

any authorized representative of the director for review during normal business hours:

- (a) Compliance demonstration records for finishing operations.
- (b) Compliance demonstration records for strippable spray booth materials.
- (c) Work practice implementation plan records.
- (d) Monitoring records for VOC emission control systems.

(2) Compliance demonstration records for finishing operations.

For any finishing operation subject to paragraph (D) of this rule, the owner or operator shall maintain the following records:

- (a) A record of the VOC emission requirement elected to be met under paragraphs (D)(1) to (D)(5) of this rule for each day of operation of the finishing operation.
- (b) A certified product data sheet for each finishing material that is subject to a VOC emission requirement elected to be met under paragraph (K)(2)(a) of this rule, and a certified product data sheet for any thinners or other VOC material added to the finishing materials before application.
- (c) A record of the VOC content, in pounds of VOC per pound of solids, as applied, of each finishing material, other than a stain, that is subject to a VOC content limit or a daily VOC emissions limit under paragraph (D) of this rule, including documentation on any thinner or other VOC added to the finishing material before application.
- (d) A record of the VOC content, in pounds of VOC per gallon, as applied of each stain subject to a daily VOC emissions limit under paragraph (D) of this rule, including documentation on any thinner or other VOC added to the stain before application.
- (e) For any continuous coater that is subject to a VOC content limit under paragraph (D) of this rule, the records listed under paragraph (K)(2)(e)(i), (K)(2)(e)(ii), or (K)(2)(e)(iii) of this rule, whichever is applicable pursuant to paragraph (I)(5) of this rule:
 - (i) Records pertaining to VOC content for a continuous coater:

- (a) For each day of operation, the gallons of each material (finishing material and thinner) added to the continuous coater reservoir.
 - (b) For each day of operation, the VOC content of the finishing material in the reservoir and the VOC content as calculated from records.
 - (ii) Records pertaining to VOC content and viscosity measurements for a continuous coater:
 - (a) For each day of operation, the gallons of each material (finishing material and thinner) added to the continuous coater reservoir and the viscosity measurements.
 - (b) The VOC content and viscosity of the initial finishing material.
 - (c) Data that demonstrates the correlation between the viscosity of the finishing material and the VOC content of the finishing material in the reservoir.
 - (iii) Records pertaining to a rolling thirty-day average VOC content for a dip coater:
 - (a) For each day of operation, the gallons of each material (finishing material and thinner) added to the dip coater reservoir.
 - (b) The VOC content (in pounds VOC per gallon) and solids content (in pounds of solids per gallon) for each material added to the dip coater reservoir.
 - (c) For each day of operation, the rolling thirty-day average VOC content in pounds of VOC per pound of solids, as determined in accordance with paragraph (I)(5)(c) of this rule.
- (f) For a VOC emission control system that is employed to meet paragraph (D)(3) of this rule and that has an overall control efficiency of less than eighty-one per cent, the VOC content in pounds of VOC per gallon of solids and the required overall control efficiency, as determined in accordance with paragraph (I)(6) of this rule, for each topcoat and sealer being controlled.
- (g) For a finishing operation subject to a daily VOC emissions limit under paragraph (D)(4) or (D)(5) of this rule, the amounts of finishing materials

employed for each day of operation, the daily actual VOC emissions and the daily VOC emissions limit.

- (h) For a VOC emission control system that is employed to meet paragraph (D)(3), (D)(4), or (D)(5) of this rule, the monitoring records specified under paragraph (K)(5) of this rule.

(3) Compliance demonstration records for strippable spray booth materials.

The owner or operator of a wood furniture manufacturing operation employing a strippable spray booth material subject to the VOC content limit in paragraph (E) of this rule shall maintain records of the following:

- (a) A certified product data sheet for each strippable spray booth material as received and a certified product data sheet for any thinner added to a strippable spray booth material.
- (b) The VOC content, in pounds of VOC per pound of solids, as applied, of each strippable spray booth material employed.

(4) Work practice implementation plan records.

The owner or operator of a wood furniture manufacturing operation subject to paragraph (E) of this rule shall maintain on-site the work practice implementation plan and all records associated with fulfilling the requirements of that plan, including, but not limited to the following:

- (a) Records demonstrating that the operator training program required by 40 CFR 63.803(b) is in place.
- (b) Records collected in accordance with the inspection and maintenance plan required by 40 CFR 63.803(c).
- (c) Records associated with the cleaning solvent accounting system required by 40 CFR 63.803(d).
- (d) Records associated with the limitation on the use of conventional air spray guns showing total finishing material usage and the percentage of finishing materials applied with conventional air spray guns for each semiannual period as required by 40 CFR 63.803(h)(5).
- (e) Copies of documentation such as logs developed to demonstrate that the other provisions of the work practice implementation plan are followed.

(5) Monitoring records for VOC emission control systems.

For any VOC emission control system subject to paragraph (H) of this rule, the owner or operator shall maintain monitoring records as follows:

(a) Where a thermal oxidizer is employed:

- (i) Continuous records of the firebox temperature.
- (ii) Records of all three-hour block averages of the firebox temperature during operation of the finishing operation.
- (iii) A record of the operating limit established under paragraph (J)(2) of this rule.
- (iv) Records of the times and durations of all periods during process or control operation when the monitoring device is not working.

(b) Where a catalytic oxidizer is employed:

- (i) Continuous records of the temperature upstream and, if the owner or operator elects to comply with paragraphs (J)(2)(b)(i) and (J)(2)(b)(ii) of this rule, the temperature difference across the catalyst bed.
- (ii) Records of three-hour block averages of the temperature upstream and, if the owner or operator elects to comply with paragraphs (J)(2)(b)(i) and (J)(2)(b)(ii) of this rule, the temperature difference across the catalyst bed during operation of the finishing operation.
- (iii) A record of the operating limits established under paragraph (J)(2) of this rule.
- (iv) Records of the times and durations of all periods during process or control operation when the monitoring device is not working.
- (v) If the owner or operator elects to comply with paragraphs (J)(2)(b)(iii) and (J)(2)(b)(iv) of this rule, records from the inspection and maintenance plan for the catalytic incinerator as specified in paragraph (J)(2)(b)(iv) of this rule.

(c) Where a regenerative carbon adsorber is employed.

- (i) A record of the total regenerative steam mass or volumetric flow for each carbon bed regeneration cycle.

- (ii) Record of the temperature of the carbon bed after each regeneration cycle [and within fifteen minutes of completing any cooling cycle].
 - (iii) A record of the operating limits established under paragraph (J)(2) of this rule.
 - (iv) Records of the times and durations of all periods during process or control operation when either monitoring device is not working.
- (d) Where a concentrator is employed:
- (i) Continuous records of the temperature of the desorption concentrate stream and the pressure drop of the dilute stream across the concentrator.
 - (ii) Records of all three-hour block averages of the temperature of the desorption concentrate stream during operation of the finishing operation.
 - (iii) Records of all three-hour block averages of the pressure drop of the dilute stream across the concentrator during operation of the finishing operation.
 - (iv) A record of the operating limits established under paragraph (J)(2) of this rule.
 - (v) Records of the times and durations of all periods during process or control operation when either monitoring device is not working.
- (e) Where an organic monitoring device is employed for monitoring the concentration level at the outlet of control device:
- (i) Continuous records of the concentration level of the outlet of the control device.
 - (ii) Records of all three-hour block averages of the concentration level during operation of the finishing operation.
 - (iii) A record of the operating limit established under paragraph (J)(2) of this rule.
 - (iv) Records of the times and durations of all periods during process or control operation when the monitoring device is not working.

- (f) For any capture system bypass line that could divert flow (i.e., VOC emissions) away from the control device to the atmosphere, the owner or operator shall maintain the following monitoring records, whichever is applicable:
- (i) Where a flow indicator control position indicator, valve closure monitoring system, or flow direction indicator is employed to monitor the bypass line:
 - (a) Hourly records of whether the monitoring device was operating and whether a diversion of flow (VOC emissions) to the atmosphere was detected at any time during the hour.
 - (b) A record indicating that a monthly inspection of the monitoring device, if required under this rule, has been done.
 - (c) Records of the times and durations of all periods when the monitoring device is not operating or flow (VOC emissions) is diverted to the atmosphere.
 - (ii) Where a car-seal or a lock-and-key type configuration is employed to secure the bypass line valve in the non-diverting position:
 - (a) A record indicating that a monthly visual inspection of the seal or closure mechanism has been done.
 - (b) Records of the times and durations of all periods when the seal mechanism is broken, the bypass line valve position has changed, the serial number of the broken car-seal has changed, or when the key to unlock the bypass line valve has been checked out.
 - (iii) Where an automatic shutdown system is employed, a record indicating that a monthly inspection of the system has been done.
- (g) For monthly (or more frequent) inspections of the VOC emission control system and monitoring equipment conducted pursuant to paragraph (H) (12) of this rule, a record of the results of each inspection.

(L) Reporting.

- (1) (General) The provisions under paragraph (L) of this rule describe the contents of reports and identify the reporting dates for the following reports:

(a) Initial compliance status report.

(b) Semiannual compliance status reports.

(2) Initial compliance status report.

The owner or operator of a wood furniture manufacturing operation subject to this rule shall submit an initial compliance status report within sixty calendar days after the compliance date specified in paragraph (G) of this rule as follows:

(a) For any finishing operation subject to paragraph (D) of this rule, the owner or operator shall state in the initial compliance status report which one of paragraphs (D)(1) to (D)(5) of this rule is elected to be met.

(b) For any topcoat or sealer that is subject to the VOC content limit of paragraph (D)(1), (D)(2), (D)(4)(b), or (D)(5)(b) of this rule and that complies with paragraphs (I)(1) to (I)(4) of this rule, the owner or operator shall state in the initial compliance status report that compliant coatings for the topcoats and sealers, as applicable, are being used.

(c) For any topcoat or sealer that is applied by means of a continuous coater, that is subject to the VOC content limit of paragraph (D)(1), (D)(2), (D)(4)(b), or (D)(5)(b) of this rule, and that complies with paragraph (I)(5) of this rule, the owner or operator shall state the following in the initial compliance status report, as applicable:

(i) That compliant coatings are being used, as determined paragraph (I)(5)(a) of this rule for VOC content for a continuous coater.

(ii) That compliant coatings are being used, as determined paragraph (I)(5)(b) of this rule for VOC content and viscosity measurements for a continuous coater; and shall submit data that demonstrates the correlation between the viscosity of the finishing material and the VOC content of the finishing material in the reservoir.

(iii) That compliant coatings are being used, as determined paragraph (I)(5)(c) of this rule for the rolling thirty-day average VOC content for a dip coater.

(d) For any finishing operation that is equipped with a VOC emission control system to comply with paragraph (D)(3) of this rule, the owner or operator shall submit the following in the initial compliance status report:

- (i) Information on designated topcoats and sealers to be controlled and the data recorded pursuant to paragraph (I)(6) of this rule that demonstrate the required overall control efficiency for each topcoat and sealer to be controlled.
- (ii) Identification and description of each monitoring device employed to comply with paragraph (H) of this rule.
- (iii) The results of compliance tests conducted pursuant to paragraph (J) of this rule to determine the overall control efficiency of the VOC emission control system and the control efficiency of any thermal or catalytic oxidizer within the VOC emission control system.
- (iv) A complete test report for any compliance tests of the VOC emission control system.

A complete test report shall include a brief process description, sampling site description, description of sampling and analysis procedures and any modifications to standard procedures, quality assurance procedures, record of operating conditions during the test, record of preparation of standards, record of calibrations, raw data sheets for field sampling, raw data sheets for field and laboratory analyses, documentation of calculations, and any other information required by the test method.

- (v) For any compliance tests of the VOC emission control system, the compliance test monitoring data recorded pursuant to paragraph (J) (2) of this rule, including the operating parameter values established for any monitoring device.
- (e) For any finishing operation that is equipped with a VOC emission control system to comply with paragraph (D)(4)(a) or (D)(5)(a) of this rule, the owner or operator shall submit in the initial compliance status report the information specified under paragraphs (L)(2)(d)(ii) to (L)(2)(d)(iv) of this rule.
- (f) For any wood furniture manufacturing operation subject to paragraph (E) of this rule, the owner or operator shall state in the initial compliance status report that compliant coatings for strippable spray booth materials are being used.
- (g) For wood furniture manufacturing operations subject to paragraph (F) of this rule, the owner or operator shall state in the initial compliance status

report that the work practice implementation plan has been developed and that procedures have been established for implementing the provisions of the plan.

(3) Semiannual compliance status reports.

The owner or operator of a wood furniture manufacturing operation subject to this rule shall submit semiannual compliance status reports no later than thirty calendar days after the end of each six-month period to the appropriate Ohio EPA district office or local air agency. The first report shall be submitted no later than thirty calendar days after the end of the first six-month period following the compliance date. Subsequent reports shall be submitted no later than thirty calendar days after the end of each six-month period following the first report or no later than thirty calendar days after the end of each six-month period otherwise established within a permit issued for the wood furniture manufacturing operation. For each semiannual compliance status report, the owner or operator shall submit the following information for the six-month period covered by the report:

- (a) For any finishing operation subject to paragraph (D) of this rule, the owner or operator shall state in the semiannual compliance status report any changes to the previous reporting of which one of paragraphs (D)(1) to (D)(5) of this rule is elected to be met.
- (b) For any topcoat or sealer that is applied by means of a continuous coater, any changes to the means of compliance previously reported. If the change pertains to the use of the procedures of paragraph (I)(5)(b) of this rule for the VOC content and viscosity measurements of a continuous coater, the owner or operator shall submit data that demonstrates the correlation between the viscosity of the finishing material and the VOC content of the finishing material in the reservoir.
- (c) For any VOC emission control system employed to meet paragraph (D)(3), (D)(4)(a), or (D)(5)(a) of this rule, any changes to monitoring devices previously reported and required under paragraph (H) of this rule.
- (d) If any subsequent compliance tests of the VOC emission control system are conducted during the semiannual reporting period after the initial compliance status report has been submitted, the semiannual compliance status report shall include the results of each compliance test, a complete test report, and the compliance test monitoring data as described under paragraphs (L)(2)(d)(ii) to (L)(2)(d)(iv) of this rule.

(e) Compliance certification for semiannual reporting period.

The owner or operator shall submit with the semiannual compliance status report, the following compliance certifications, where applicable:

(i) For any topcoat or sealer that is subject to the VOC content limit of paragraph (D)(1), (D)(2), (D)(4)(b), or (D)(5)(b) of this rule and that complies with paragraphs (I)(1) to (I)(4) of this rule, the compliance certification shall state that compliant coatings for topcoats and sealers, as applicable, have been used each operating day in the semiannual reporting period, or should otherwise identify the periods of use of noncompliant coatings for topcoats and sealers, as applicable, the reasons for the use of noncompliant coatings, and the amounts and VOC contents of each noncompliant coating used. Use of a noncompliant coating is a separate violation for each day the noncompliant coating is used.

(ii) For any topcoat or sealer that is applied by means of a continuous coater, that is subject to the VOC content limit of paragraph (D)(1), (D)(2), (D)(4)(b), or (D)(5)(b) of this rule, and that complies by the procedures of paragraph (I)(5) of this rule, the compliance certification shall state the following, whichever is applicable:

(a) (Compliance by VOC content for a continuous coater) The compliance certification shall state that compliant coatings, as determined by paragraph (I)(5)(a) of this rule, have been used each operating day in the semiannual reporting period, or should otherwise identify the periods of use of noncompliant coatings, the reasons for the use of noncompliant coatings, and the amounts and VOC contents of each noncompliant coating used. Use of a noncompliant coating is a separate violation for each day the noncompliant coating is used

(b) (Compliance by VOC content and viscosity measurements for a continuous coater) The compliance certification shall state that compliant coatings, as determined by paragraph (I)(5)(b) of this rule, have been used each operating day in the semiannual reporting period, or should otherwise identify the periods of use of noncompliant coatings, the reasons for the use of noncompliant coatings, and the amounts and VOC contents of each noncompliant coating used. Additionally, the certification shall state that the viscosity of the finishing

material in the reservoir has not been less than the viscosity of the initial finishing material, that is, the material that is initially mixed and placed in the reservoir, for any day in the semiannual reporting period. Use of a noncompliant coating is a separate violation for each day the noncompliant coating is used.

- (c) (Compliance by rolling thirty-day average VOC content for a dip coater) The compliance certification shall state that compliant coatings, as determined by paragraph (I)(5)(c) of this rule, have been used each operating day in the semiannual reporting period, or should otherwise identify the periods of use of noncompliant coatings, the reasons for the use of noncompliant coatings, and the amounts and VOC contents of each noncompliant coating used. Use of a noncompliant coating is a separate violation for each day the noncompliant coating is used.
- (iii) For any finishing operation that is equipped with a VOC emission control system to comply with paragraph (D)(3) of this rule:

 - (a) The compliance certification shall state that the three-hour block averages of the monitoring parameters recorded pursuant to paragraph (K)(5) of this rule had complied with the operating limits (operating parameter values) for the monitoring parameters established under paragraph (J)(2) of this rule during of all periods of operation of the finishing operation; or should otherwise identify the times and durations of all periods of noncompliance and the reasons for noncompliance.
 - (b) The compliance certification shall identify the times and durations of all periods during process or control operation when the monitoring device is not working, as recorded pursuant to paragraph (K)(5) of this rule.
 - (c) For any capture system bypass line, the compliance certification shall identify the times and durations of all periods in which the captured VOC emissions were discharged to atmosphere instead of a control device, as recorded pursuant to paragraph (K)(5)(f) of this rule and the reasons for the discharges to atmosphere.

- (d) The compliance certification shall state that the overall reduction of VOC emissions, based on the most recent compliance test conducted in accordance with paragraph (J) of this rule, has met the overall reduction of VOC emissions required under paragraph (D)(3) of this rule for each topcoat and sealer designated for control during the semiannual reporting period, or should otherwise identify the periods of noncompliance and the reasons for noncompliance.
- (iv) For any finishing operation that is equipped with a VOC emission control system to comply with paragraph (D)(4)(a) or (D)(5)(a) of this rule, the compliance certification shall contain the information specified under paragraphs (L)(3)(e)(iii)(a) to (L)(3)(e)(iii)(c) of this rule.
- (v) For finishing operations that are subject to the daily VOC emissions limit under paragraph (D)(4) or (D)(5) of this rule, the compliance certification shall state that the daily actual VOC emissions did not exceed the daily VOC emissions limit for the finishing materials selected for inclusion in the daily VOC emissions limit for each operating day during the semiannual reporting period, or should otherwise identify for each day of noncompliance the daily actual VOC emissions, the daily VOC emissions limit, the finishing materials selected for inclusion in the daily VOC emissions limit, and the reasons for noncompliance.
- (vi) For any wood furniture manufacturing operation subject to paragraph (E) of this rule for strippable spray booth materials, the compliance certification shall state that compliant coatings for strippable spray booth materials have been used each day in the semiannual reporting period, or should otherwise identify each day noncompliant coatings for strippable spray booth materials were used., the reasons for the use of noncompliant coatings, and the amounts and VOC contents of each noncompliant coating used. Use of a noncompliant coating is a separate violation for each day the noncompliant coating is used
- (vii) For wood furniture manufacturing operations subject to the work practice requirements of paragraph (F) of this rule, the compliance certification shall state that the work practice implementation plan is being followed, or should otherwise identify the provisions of the plan that have not been implemented and each day the provisions were not implemented.

- (viii) The compliance certification shall identify and describe any corrective actions considered and implemented for any noncompliance being reported in the compliance certification.
- (ix) The compliance certification shall be signed by a responsible official of the company that owns or operates the wood furniture manufacturing operations.

(M) Special provisions for owners or operators electing to use emissions averaging.

(1) The owner or operator of wood furniture manufacturing operations electing to comply with the daily VOC emissions limit in paragraph (D)(4) or (D)(5) of this rule shall submit to the director for approval a plan addressing the following provisions:

(a) Program goals and rationale as follows:

- (i) Provide a summary of the reasons why the owner or operator of wood furniture manufacturing operations would like to comply with the VOC emission limitations through the procedures established in paragraph (D)(4) or (D)(5) of this rule.
- (ii) Provide a summary of how averaging can be used to meet the VOC emission limitations.
- (iii) Document that the additional environmental benefit requirement is being met through the use of the equations in paragraph (D)(4) or (D)(5) of this rule. These equations ensure that the wood furniture manufacturing operations achieve an additional ten per cent reduction in emissions when compared to wood furniture manufacturing operations using a compliant coatings approach to meet the requirements of the rule.

(b) Program scope as follows:

- (i) Include the types of finishing materials that will be included in the wood furniture manufacturing operations' averaging program.
- (ii) Stains, basecoats, washcoats, sealers, and topcoats may be used in the averaging program.
- (iii) Finishing materials that are applied using continuous coaters may only be used in an averaging program if the owner or operator of the

wood furniture manufacturing operations can determine the amount of finishing material used each day.

(c) For program baseline, each finishing material included in the averaging program shall be the lower of the actual or allowable emission rate as of May 27, 2005 for facilities located in Butler, Clermont, Hamilton, or Warren county or August 25, 2008 for facilities located in Ashtabula, Cuyahoga, Geauga, Lake, Lorain, Medina, Portage, or Summit county.

(d) Quantification procedures as follows:

(i) Describe how emissions and changes in emissions will be quantified, including methods for quantifying usage of each finishing material. Quantification procedures for VOC content are included in paragraph (I) of this rule.

(ii) Quantification methods used shall be accurate enough to ensure that the wood furniture manufacturing operations' actual emissions are less than the allowable emissions, as calculated using the equations in paragraph (D)(4) or (D)(5) of this rule, on a daily basis.

(e) Monitoring, record keeping, and reporting as follows:

(i) Provide a summary of the monitoring, record keeping, and reporting procedures that will be used to demonstrate daily compliance with the equations presented in paragraph (D)(4) or (D)(5) of this rule.

(ii) Monitoring, record keeping, and reporting procedures shall be structured in such a way that the Ohio EPA and owners or operators of the wood furniture manufacturing operations can determine compliance status for any day.

(2) Pending approval by the director and the USEPA of the proposed emissions averaging plan, the owner or operator shall continue to comply with this rule.

(N) Applicability notification and permit application.

(1) The owner or operator of a facility that is subject to this rule, is located in Butler, Clermont, Hamilton, or Warren county, and has an initial startup of wood furniture manufacturing operations before May 27, 2005 shall notify the appropriate Ohio EPA district office or local air agency in writing that the facility is subject to this rule. The notification, which shall be submitted not later than July 26, 2005, shall provide the information specified in paragraph (N)(5) of this rule.

- (2) The owner or operator of a facility that is subject to this rule, is located in Butler, Clermont, Hamilton, or Warren county, and has an initial startup of wood furniture manufacturing operations on or after May 27, 2005 shall notify the appropriate Ohio EPA district office or local air agency in writing that the facility is subject to this rule. The notification, which shall be submitted not later than either the date of initial startup of the facility or July 26, 2005 (whichever is later), shall provide the information specified in paragraph (N)(5) of this rule. The application for a permit-to-install under rule 3745-31-02 of the Administrative Code may be used to fulfill the notification requirements of this paragraph.
- (3) The owner or operator of a facility that is subject to this rule, is located in Ashtabula, Cuyahoga, Geauga, Lake, Lorain, Medina, Portage, or Summit county, and has an initial startup of wood furniture manufacturing operations before August 25, 2008 shall notify the appropriate Ohio EPA district office or local air agency in writing that the facility is subject to this rule. The notification, which shall be submitted not later than October 24, 2008, shall provide the information specified in paragraph (N)(5) of this rule.
- (4) The owner or operator of a facility that is subject to this rule, is located in Ashtabula, Cuyahoga, Geauga, Lake, Lorain, Medina, Portage, or Summit county, and has an initial startup of wood furniture manufacturing operations on or after August 25, 2008 shall notify the appropriate Ohio EPA district office or local air agency in writing that the facility is subject to this rule. The notification, which shall be submitted not later than either the date of initial startup of the facility or October 24, 2008 (whichever is later), shall provide the information specified in paragraph (N)(5) of this rule. The application for a permit-to-install under rule 3745-31-02 of the Administrative Code may be used to fulfill the notification requirements of this paragraph.
- (5) The notification required in paragraphs (N)(1) to (N)(4) of this rule shall include the following information:
 - (a) Name and address of the owner or operator.
 - (b) Address (i.e., physical location) of the facility.
 - (c) Equipment description and Ohio EPA application number (if assigned) of any wood furniture manufacturing operations.
 - (d) Identification of the applicable requirements, the means of compliance, and the compliance date for the wood furniture manufacturing operations under this rule.

- (e) An application for an operating permit or an application for a modification to an operating permit in accordance with Chapter 3745-77 of the Administrative Code (for sources subject to the Title V permit program) or an application for a permit-to-install and operate or an application for a modification to a permit-to-install and operate in accordance with Chapter 3745-31 of the Administrative Code (for sources not subject to the Title V permit program) for each subject process that meets one of the following:
- (i) The process does not possess an effective operating permit or permit-to-install and operate.
 - (ii) The process possesses an effective operating permit or permit-to-install and operate and the owner or operator cannot certify in writing to the director that such subject process is in compliance with this rule. An application for an operating permit or permit-to-install and operate is not required provided the subject process is operating under an effective permit and certifies compliance. Such certification shall include all compliance certification requirements under paragraph (L)(2) of this rule.

[Comment: Applications for sources not subject to Chapter 3745-77 of the Administrative Code, requiring submittal prior to June 30, 2008, were submitted in accordance with Chapter 3745-35 of the Administrative Code.]

Effective: 3/27/2022
Five Year Review (FYR) Dates: 11/29/2021 and 11/29/2026

CERTIFIED ELECTRONICALLY

Certification

03/17/2022

Date

Promulgated Under: 119.03
Statutory Authority: 3704.03(E)
Rule Amplifies: 3704.03(A), 3704.03(E)
Prior Effective Dates: 05/27/2005, 08/25/2008, 10/15/2015

3745-21-18

Commercial motor vehicle and mobile equipment refinishing operations.

[Comment: For dates and availability of non-regulatory government publications, publications of recognized organizations and associations, federal rules, and federal statutory provisions referenced in this rule, see paragraph (JJ) of rule 3745-21-01 of the Administrative Code titled "referenced materials."]

(A) Applicability.

(1) All commercial motor vehicle and mobile equipment refinishing operations (sources), regardless of date of construction or modification, that are located in Butler, Clark, Clermont, Greene, Hamilton, Miami, Montgomery, or Warren county shall comply with the following:

(a) Paragraphs (C)(1) and (C)(2) of this rule beginning May 1, 2009.

(b) Paragraphs (C)(3) to (C)(6) of this rule beginning April 11, 2006.

(2) All commercial motor vehicle and mobile equipment refinishing operations (sources), regardless of date of construction or modification, that are located in Ashtabula, Cuyahoga, Geauga, Lake, Lorain, Medina, Portage, or Summit county shall achieve compliance with this rule by no later than April 2, 2010.

(B) Definitions.

The definitions applicable to this rule are contained in paragraph (D) of rule 3745-21-01 of the Administrative Code.

(C) Operating requirements.

Except where exempt under paragraph (D) of this rule a person at a facility subject to this rule shall do the following:

(1) Not apply to mobile equipment or mobile equipment components any automotive pretreatment, automotive primer-surfacer, automotive primer-sealer, automotive topcoat, or automotive specialty coatings, including any VOC-containing materials added to the original coating supplied by the manufacturer, that contain VOCs in excess of the limits specified in the table of this rule:

Table: Allowable content of VOCs in mobile equipment repair and refinishing coatings, as applied (in weight of VOC per volume of coating, excluding water and non-VOC or exempt solvents)

Coating Type	Limit (pounds VOC per gallon of coating, excluding water and exempt solvents)	Limit (grams VOC per liter of coating, excluding water and exempt solvents)
pretreatment primer	6.5	780
primer-surfacer	4.8	575
primer-sealer	4.6	550
topcoat(single-stage)	5.0	600
topcoat (two-stage basecoat/clearcoat)	5.0	600
topcoat (three or four-stage basecoat/clearcoat)	5.2	625
multi-colored topcoat	5.7	680
automotive specialty	7.0	840

(2) Calculate the VOC content of the coatings employed in accordance with the following:

- (a) Except for multi-stage topcoats, the mass of VOC per combined volume of VOC and coating solids, excluding water and exempt solvents, shall be calculated by the following equation:

$$\text{VOC} = \frac{(W_v - W_w - W_{ec})}{(V - V_w - V_{ec})} \frac{(W_v - W_w - W_{ec})}{(V - V_w - V_{ec})}$$

where:

VOC = VOC content in pounds per gallon of coating, excluding water and exempt solvents.

~~W_v~~W_v = mass of total volatiles, in pounds.

~~W_w~~W_w = mass of water, in pounds.

~~W_{ec}~~W_{ec} = mass of exempt solvents, in pounds.

V = volume of coating, in gallons.

V_w = volume of water, in gallons.

V_{ec} = volume of exempt solvents, in gallons.

- (b) The VOC content of a multi-stage topcoat shall be calculated by the following equation:

$$VOC_{multi} = \frac{VOC_{bc} + \sum_{i=0}^M VOC_{mci} + 2(VOC_{cc})}{M + 3}$$

where:

VOC_{multi} = VOC content of multistage topcoat, in pounds per gallon, excluding water and exempt solvents.

VOC_{bc} = VOC content of basecoat, in pounds per gallon, excluding water and exempt solvents.

VOC_{mci} = VOC content of each midcoat, in pounds per gallon, excluding water and exempt solvents.

VOC_{cc} = VOC content of the clear coat, in pounds per gallon, excluding water and exempt solvents.

M = number of midcoats.

(The VOC content of each coating shall be measured in accordance with USEPA method 24.)

- (3) Use one or more of the following application techniques, in accordance with manufacturer's specifications, to apply any coating containing a VOC as a pretreatment, primer, sealant, basecoat, clear coat, or topcoat to mobile equipment for commercial purposes:
- (a) Flow or curtain coating.
 - (b) Dip coating.
 - (c) Roller coating.
 - (d) Brush coating.

- (e) Cotton-tipped swab application.
 - (f) Electro-deposition coating.
 - (g) HVLP spraying.
 - (h) Electrostatic spray.
 - (i) Airless spray.
 - (j) Air-assisted airless spray.
 - (k) Any other coating application method that the owner or operator of ~~the~~ a facility or manufacturer demonstrates and Ohio EPA determines achieves emission reductions equivalent to HVLP or electrostatic spray application methods. This demonstration shall be submitted to the director for approval ~~to the director~~. Any equivalent coating application method approved by the director shall be submitted to the USEPA as a revision to the Ohio state implementation plan ~~for ozone~~.
- (4) Be properly trained in the use of an HVLP sprayer, or equivalent application, in accordance with manufacturer's specifications, and in the handling of a coating and any solvents used to clean the sprayer.
- (5) Ensure that the spray guns used to apply mobile equipment repair and refinishing coatings ~~shall be~~ are cleaned by one of the following:
- (a) An enclosed spray gun cleaning system that is kept closed when not in use.
 - (b) Un-atomized discharge of solvent into a paint waste container that is kept closed when not in use.
 - (c) Disassembly of the spray gun and cleaning in a vat that is kept closed when not in use.
 - (d) Atomized spray into a paint waste container that is fitted with a device designed to capture atomized solvent emissions.
- (6) Store the following materials in nonabsorbent, non-leaking containers and keep these containers closed at all times when not in use:
- (a) Fresh coatings.
 - (b) Used coatings.

- (c) Solvents.
- (d) VOC-containing additives and materials.
- (e) VOC-containing waste materials.
- (f) Cloth, paper, or absorbent applicators moistened with any of the items listed in this subsection.

(D) Exemptions.

The following coating applications shall be exempt from this rule:

- (1) The application of a coating for graphic designs, stenciling, lettering or other identification marking through the use of an air brush method.
- (2) The application of a coating sold in a non-refillable aerosol container.
- (3) The application of a coating to mobile equipment solely for repair of small areas of surface damage or minor imperfections.

(E) Record keeping and reporting.

- (1) Each owner or operator subject to the provisions of this rule shall submit documentation to the appropriate Ohio EPA district office or local air agency sufficient to demonstrate that high efficiency transfer application techniques of coatings required in this rule are in use at their facility. ~~The documentation also shall verify, and verify~~ that all employees applying coatings are properly trained in the use of an HVLP sprayer, or equivalent application, and that all employees are trained in the handling of a coating and any solvents used to clean the sprayer. ~~This documentation shall be submitted to the appropriate Ohio EPA district office or local air agency. In addition, the~~ The owner or operator shall retain the documentation on site and make the documentation available to the appropriate Ohio EPA district office or local air agency upon request. The documentation shall be submitted by the following:
 - (a) June 10, 2006 for sources covered under paragraph (A)(1)(b) of this rule.
 - (b) June 10, 2009 for sources covered under paragraph (A)(1)(a) of this rule.
 - (c) No later than April 2, 2010 for sources covered under paragraph (A)(2) of this rule.

- (2) Each owner or operator subject to the provisions of this rule shall maintain records for a period of five years of the amount and VOC content of each coating employed and report to the director all emissions in excess of the limits specified in the table of this rule within forty-five days after each exceedance is discovered.

Effective: 3/27/2022

Five Year Review (FYR) Dates: 11/29/2021 and 11/29/2026

CERTIFIED ELECTRONICALLY

Certification

03/17/2022

Date

Promulgated Under: 119.03
Statutory Authority: 3704.03(E)
Rule Amplifies: 3704.03(A), 3704.03(E)
Prior Effective Dates: 02/10/2006, 08/25/2008, 04/02/2009, 10/15/2015

3745-21-19

Control of volatile organic compound emissions from aerospace manufacturing and rework facilities.

[Comment: For dates and availability of non-regulatory government publications, publications of recognized organizations and associations, federal rules, and federal statutory provisions referenced in this rule, see paragraph (JJ) of rule 3745-21-01 of the Administrative Code titled "referenced materials."]

(A) Applicability.

- (1) Except as otherwise provided in paragraph (A)(2) of this rule, this rule shall apply to any aerospace manufacturing or rework facility that is located in Ashtabula, Butler, Clermont, Cuyahoga, Geauga, Hamilton, Lake, Lorain, Medina, Portage, ~~or~~ Summit, or Warren county.
- (2) Excluded from this rule is any aerospace manufacturing or rework facility that has the potential to emit for VOC of less than 25.0 tons per year for all operations combined where aerospace components and vehicles are cleaned or coated. The activities, operations, and materials described in paragraphs (C)(2) and (C)(3) of this rule are not included in such determination of potential to emit for VOC.

(B) Definitions.

The definitions applicable to this rule are contained in paragraphs (B) and (AA) of rule 3745-21-01 of the Administrative Code.

(C) Overall requirements for an aerospace manufacturing or rework facility.

- (1) Except as otherwise provided in paragraphs (C)(2) and (C)(3) of this rule, any owner or operator of an aerospace manufacturing or rework facility that is subject to this rule shall comply with paragraphs (D) to (L) of this rule.
- (2) This rule does not apply to the following activities where cleaning and coating of aerospace components and vehicles may take place:
 - (a) Research and development.
 - (b) Quality control.
 - (c) Laboratory testing.
 - (d) Electronic parts and assemblies (except for cleaning and coating of completed assemblies).

(3) This rule does not apply to rework operations performed on antique aerospace vehicles and components.

(D) VOC emission limitations and application methods for coating operations.

(1) Except as otherwise provided in paragraphs (D)(2) and (D)(3) of this rule, a person shall not apply to aerospace vehicles or components any coating that contains VOC in excess of the following VOC content limits:

(a) VOC content limits for primers, topcoats, and chemical milling maskants.

Type of coating	VOC content limit (pounds of VOC per gallon of coating, excluding water and exempt solvents, as applied)
Primer	2.9
Primer for general aviation rework facility	4.5
Exterior primer for large commercial aircraft (components or fully assembled)	5.4
Topcoat	3.5
Topcoat for general aviation rework facility	4.5
Self-priming topcoat	3.5
Self-priming topcoat for general aviation rework facility	4.5
Chemical milling maskant, type I	5.2
Chemical milling maskant, type II	1.3

(b) VOC content limits for specialty coatings.

Type of specialty coating	VC content limit (pounds of VOC per gallon of coating, excluding water and exempt solvents, as applied)
Ablative coating	5.0
Adhesion promoter	7.4

Adhesive bonding primer cured above two hundred fifty degrees Fahrenheit	8.6
Adhesive bonding primer cured at two hundred fifty degrees Fahrenheit or below	7.1
Antichafe coating	5.5
Bearing coating	5.2
Bonding maskant	10.3
Caulking and smoothing compounds	7.1
Chemical agent-resistant coating	4.6
Clear coating	6.0
Commercial exterior aerodynamic structure primer	5.4
Commercial interior adhesive	6.3
Compatible substrate primer	6.5
Corrosion prevention compound	5.9
Critical use and line sealer maskant	8.5
Cryogenic flexible primer	5.4
Cryoprotective coating	5.0
Cyanoacrylate adhesive	8.5
Dry lubricative material	7.3
Electric or radiation-effect coating	6.7
Electrostatic discharge and electromagnetic interference (EMI) coating	6.7
Elevated temperature Skydrol-resistant commercial primer	6.2
Epoxy polyamide topcoat	5.5

Fire-resistant (interior) coating	6.7
Flexible primer	5.3
Flight test coatings; all other	7.0
Flight test coatings: missile or single use aircraft	3.5
Fuel tank adhesive	5.2
Fuel tank coating	6.0
High temperature coating	7.1
Insulation covering	6.2
Intermediate release coating	6.3
Lacquer	6.9
Metallized epoxy coating	6.2
Mold release	6.5
Nonstructural adhesive	3.0
Optical anti-reflective coating	6.3
Part marking coating	7.1
Pretreatment coating	6.5
Rain erosion-resistant coating	7.1
Rocket motor bonding adhesive	7.4
Rocket motor nozzle coating	5.5
Rubber-based adhesive	7.1
Scale inhibitor	7.3
Screen print ink	7.0
Seal coat maskant	10.3

Sealants: extrudable, rollable, or brushable sealant	2.3
Sealants: sprayable sealant	5.0
Silicone insulation material	7.1
Solid film lubricant	7.3
Specialized function coating	7.4
Structural autoclave adhesive	0.5
Structural nonautoclavable adhesive	7.1
Temporary protective coating	2.7
Thermal control coating	6.7
Wing coating	7.1
Wet fastener installation coating	5.6

(2) VOC emission control system for a coating operation.

In lieu of the VOC content limit for a coating subject to paragraph (D)(1) of this rule, a VOC emission control system shall be used that achieves, for the coating employed and designated for control, an overall reduction of VOC emissions that is equal to or greater than eighty-one per cent by weight. Also, if the VOC emission control system includes a thermal or catalytic oxidizer, the control efficiency of the thermal or catalytic oxidizer for VOC emissions shall be at least ninety per cent by weight.

(3) The following coating applications are exempt from the VOC content limits listed in paragraphs (D)(1)(a) and (D)(1)(b) of this rule:

- (a) Aerosol coatings.
- (b) Touchup and repair coatings.
- (c) DOD classified coatings.
- (d) Coating of space vehicles.
- (e) Coatings that meet the following low usage restrictions at the facility:

- (i) Annual total usage of each separate coating formulation does not exceed fifty gallons.
 - (ii) Combined annual total usage of such coating formulations does not exceed two hundred gallons.
- (4) Except as otherwise provided in paragraph (D)(5) of this rule, a person shall use one or more of the following application methods for applying primers and topcoats (including self-priming topcoat) to aerospace vehicles or components:
- (a) Flow/curtain applications.
 - (b) Dip coat application.
 - (c) Roll coating.
 - (d) Brush coating.
 - (e) Cotton tipped swab application.
 - (f) Electrodeposition (dip) coating.
 - (g) High volume low pressure (HVLP) spraying.
 - (h) Electrostatic spray application.
 - (i) Other coating application methods that achieve VOC emission reductions equivalent to HVLP or electrostatic spray application methods, as determined according to 40 CFR 63.750(i).
- (5) The following situations are exempt from paragraph (D)(4) of this rule:
- (a) Any situation that normally requires the use of an airbrush or an extension on the spray gun to properly reach limited access spaces.
 - (b) The application of coatings that contain fillers that adversely affect atomization with HVLP spray guns and that the permitting agency has determined cannot be applied by any of the application methods specified in paragraph (D)(4) of this rule.
 - (c) The application of coatings that normally have a dried film thickness of less than 0.0013 centimeter (0.0005 inch) and that the director has determined cannot be applied by any of the application methods specified in paragraph (D)(4) of this rule.

- (d) The use of airbrush application methods for stenciling, lettering, and other identification markings.
- (e) The use of handheld spray can application methods.
- (f) Touchup and repair operations.

(E) Cleaning operations.

(1) Hand wipe cleaning operations.

- (a) Except as otherwise provided in paragraph (E)(1)(b) of this rule, any cleaning solvent employed in a hand wipe cleaning operation shall meet one of the following specifications:
 - (i) Meet the definition of an aqueous cleaning solvent.
 - (ii) Have a VOC composite vapor pressure of 7.0 millimeters of mercury (3.75 inches of water) or less at twenty degrees Celsius (sixty-eight degrees Fahrenheit).
- (b) The following hand wipe cleaning operations are exempt from paragraph (E)(1)(a) of this rule:
 - (i) Cleaning during the manufacture, assembly, installation, maintenance, or testing of components of breathing oxygen systems that are exposed to the breathing oxygen.
 - (ii) Cleaning during the manufacture, assembly, installation, maintenance, or testing of parts, subassemblies, or assemblies that are exposed to strong oxidizers or reducers (e.g., nitrogen tetroxide, liquid oxygen, or hydrazine).
 - (iii) Cleaning and surface activation prior to adhesive bonding.
 - (iv) Cleaning of electronic parts and assemblies containing electronic parts.
 - (v) Cleaning of aircraft and ground support equipment fluid systems that are exposed to the fluid, including air-to-air heat exchangers and hydraulic fluid systems.
 - (vi) Cleaning of fuel cells, fuel tanks, and confined spaces.

- (vii) Surface cleaning of solar cells, coated optics, and thermal control surfaces.
- (viii) Cleaning during fabrication, assembly, installation, and maintenance of upholstery, curtains, carpet, and other textile materials used in the interior of the aircraft.
- (ix) Cleaning of metallic and nonmetallic materials used in honeycomb cores during the manufacture or maintenance of these cores, and cleaning of the completed cores used in the manufacture of aerospace vehicles or components.
- (x) Cleaning of aircraft transparencies, polycarbonate, or glass substrates.
- (xi) Cleaning and cleaning solvent usage associated with research and development, quality control, and laboratory testing.
- (xii) Cleaning operations, using nonflammable liquids, conducted within five feet of energized electrical systems (energized electrical systems means any AC or DC electrical circuit on an assembled aircraft once electrical power is connected, including interior passenger and cargo areas, wheel wells and tail sections).
- (xiii) Cleaning operations identified as essential uses under the Montreal Protocol for which the USEPA has allocated essential use allowances or exemptions in 40 CFR 82.4.

(2) Spray gun cleaning operations.

- (a) Except as otherwise provided in paragraph (E)(2)(b) of this rule, any spray gun to be cleaned shall be cleaned by one or more of the following techniques:

- (i) Enclosed system.

- (a) Clean the spray gun in an enclosed system that is closed at all times except when inserting or removing the spray gun. Cleaning shall consist of forcing solvent through the gun.

- (b) Visually inspect the seals and other potential sources of leaks associated with the enclosed system at least once per month. If leaks are found, repairs shall be made as soon as practicable, but no later than fifteen days after the leak was found. If the leak is not repaired by the fifteenth day after

detection, the cleaning solvent shall be removed, and the enclosed cleaner shall be shut down until the leak is repaired or its use is permanently discontinued.

(ii) Nonatomized cleaning.

Clean the spray gun by placing cleaning solvent in the pressure pot and forcing it through the gun with the atomizing cap in place. No atomizing air is to be used. Direct the cleaning solvent from the spray gun into a vat, drum, or other waste container that is closed when not in use.

(iii) Disassembled spray gun cleaning.

Disassemble the spray gun and clean the components by hand in a vat, which shall remain closed at all times except when in use. Alternatively, soak the components in a vat, which shall remain closed during the soaking period and when not inserting or removing components.

(iv) Atomized cleaning.

Clean the spray gun by forcing the cleaning solvent through the gun and directing the resulting atomized spray into a waste container that is fitted with a device designed to capture the atomized cleaning solvent emissions.

- (b) The cleaning of nozzle tips of automated spray equipment systems, except for robotic systems that can be programmed to spray into a closed container, shall be exempt from paragraph (E)(2)(a) of this rule.

(3) Flush cleaning operations.

- (a) Except as otherwise provided in paragraph (E)(3)(b) of this rule, the used cleaning solvent of any flush cleaning operation shall be emptied into an enclosed container or collection system that is kept closed when not in use or captured with wipers provided they comply with the housekeeping requirements of paragraph (E)(4) of this rule.
- (b) Excluded from paragraph (E)(3)(a) of this rule is any cleaning solvent that meets any of the following specifications:
- (i) Meets the definition of an aqueous cleaning solvent.

- (ii) Has a VOC composite vapor pressure of 7.0 millimeters of mercury (3.75 inches of water) or less at twenty degrees Celsius (sixty-eight degrees Fahrenheit).
 - (iii) Meets the definition of a semiaqueous cleaning solvent.
 - (4) Housekeeping measures for cleaning solvents and solvent-laden cleaning materials used in cleaning operations.
 - (a) Except for semiaqueous cleaning solvents and where excluded under paragraph (E)(4)(d) of this rule, all fresh and spent cleaning solvents shall be stored in nonabsorbent, nonleaking containers that are kept closed at all times except when filling or emptying.
 - (b) Except where excluded under paragraph (E)(4)(d) of this rule, all used solvent-laden cloths and papers, and any other absorbent applicators used for cleaning, shall be placed in nonabsorbent, nonleaking containers or bags that are kept closed at all times except when depositing or removing these materials from the container or bag.
 - (c) Except where excluded under paragraph (E)(4)(d) of this rule, the handling and transfer of cleaning solvents to or from enclosed systems, vats, waste containers, and other cleaning operation equipment that hold or store fresh or spent cleaning solvents shall be conducted in such a manner that minimizes spills.
 - (d) Excluded from paragraphs (E)(4)(a) to (E)(4)(c) of this rule is the use of any cleaning solvent that meets any of the following specifications:
 - (i) Meets the definition of an aqueous cleaning solvent.
 - (ii) Has a VOC composite vapor pressure of 7.0 millimeters of mercury (3.75 inches of water) or less at twenty degrees Celsius (sixty-eight degrees Fahrenheit).
- (F) Compliance dates.
- (1) Except where otherwise specified within this rule, any owner or operator of a facility that is subject to this rule shall comply with this rule by no later than the following dates:
 - (a) For an aerospace manufacturing or rework facility located in Ashtabula, Cuyahoga, Geauga, Lake, Lorain, Medina, Portage, or Summit county for which installation commenced before August 25, 2008, the compliance

date is either August 25, 2009 or the date of initial startup of the aerospace manufacturing or rework facility, whichever is later.

(b) For an aerospace manufacturing or rework facility located in Ashtabula, Cuyahoga, Geauga, Lake, Lorain, Medina, Portage, or Summit county for which installation commenced on or after August 25, 2008, the compliance date is the date of initial startup of the aerospace manufacturing or rework facility.

(c) For an aerospace manufacturing or rework facility located in Butler, Clermont, Hamilton or Warren county for which installation commenced before the effective date of this rule, the compliance date is either March 1, 2023 or the date of initial startup of the aerospace manufacturing or rework facility, whichever is later.

(d) For an aerospace manufacturing or rework facility located in Butler, Clermont, Hamilton or Warren county for which installation commenced on or after the effective date of this rule, the compliance date is the date of initial startup of the aerospace manufacturing or rework facility.

(2) For a VOC emission control system that is used for a coating operation to comply with paragraph (D)(2) of this rule, the owner or operator shall demonstrate the overall control efficiency of the VOC emission control system and the control efficiency of any thermal or catalytic oxidizer within the VOC emission control system by testing the coating operation and the VOC emission control system in accordance with paragraph (I) of this rule within ninety days after the coating operation's compliance date.

(3) Additional testing of the coating operation and the VOC emission control system in accordance with paragraph (I) of this rule may be required by the director to ensure continued compliance.

(G) Monitoring requirements for a VOC emission control system.

For a VOC emission control system that is used for a coating operation to comply with paragraph (D)(2) of this rule, the owner or operator shall meet the same monitoring requirements as contained in paragraph (H) of rule 3745-21-15 of the Administrative Code.

(H) Procedures for the VOC content of a coating, the VOC content of a coating applied by a dip coater, the composition of a cleaning solvent, and the VOC composite vapor pressure of a cleaning solvent.

- (1) The VOC content of a coating shall be determined by the owner or operator in accordance with paragraph (B) of rule 3745-21-10 of the Administrative Code, wherein formulation data or USEPA method 24 procedures (which include various ASTM measurement methods) may be employed.
- (2) VOC content of a coating applied by a dip coater (rolling thirty-day average VOC content).

The as applied VOC content of a coating applied by a dip coater shall be determined by the owner or operator as a rolling thirty-day average of the VOC content of the material (coating and thinner) added to the reservoir of the dip coater. The rolling thirty-day average VOC content (C_{30}), expressed in pounds of VOC per gallon of coating, excluding water and exempt solvents, as applied, shall be calculated for each day of operation of the dip coater as follows:

$$C_{30} = \frac{\sum_{i=1}^n (A_{i,30})(C_{i,VOC})}{\sum_{i=1}^n (A_{i,30})(V_{i,VOC} + V_{i,solids})}$$

Where:

$A_{i,30}$ = amount of material i added to the reservoir of the dip coater during a thirty-day period consisting of the day of operation of the dip coater plus the previous twenty-nine calendar days, expressed in gallons.

$C_{i,VOC}$ = VOC content of material i expressed in pounds of VOC per gallon.

$V_{i,solids}$ = volume fraction of solids (nonvolatile matter) in material i .

$V_{i,VOC}$ = volume fraction of VOC in material i .

i = subscript denoting a specific material (coating or thinner) added to the reservoir of the dip coater during the thirty-day period.

n = total number of materials (coatings and thinners) added to the reservoir of the dip coater during the thirty-day period.

- (3) The composition of a cleaning solvent shall be based upon data supplied by the manufacturer of the cleaning solvent. The data shall identify all components of the cleaning solvent.
- (4) The VOC composite vapor pressure of a cleaning solvent shall be determined by the owner or operator in accordance with paragraph (S) of rule 3745-21-10 of the Administrative Code.

(I) Compliance tests for VOC emission control systems.

- (1) For a VOC emission control system used to comply with paragraph (D)(2) of this rule, the owner or operator shall conduct a compliance test to determine the capture efficiency of the capture system, the control efficiency of the control device (or each control device if a combination of control devices is employed), and the overall control efficiency of the VOC emission control system in accordance with paragraph (C) of rule 3745-21-10 of the Administrative Code wherein USEPA method 25 or 25A shall be used for determining the concentration of VOC in a gas stream.
- (2) During the compliance test described in paragraph (I)(1) of this rule that demonstrates compliance, the owner or operator shall establish the operating limits (operating parameter values) for the monitoring devices required under paragraph (G) of this rule by following paragraph (J)(2) of rule 3745-21-15 of the Administrative Code.

(J) Recordkeeping.

- (1) (General) All records specified under paragraph (J) of this rule shall be retained by the owner or operator for a period of not less than five years and shall be made available to the director or any authorized representative of the director for review during normal business hours. The following types of records are to be maintained by the owner or operator of an aerospace manufacturing or rework facility subject to this rule:
 - (a) Compliance demonstration records for coating operations.
 - (b) Compliance demonstration records for cleaning operations.
 - (c) Monitoring records for VOC emission control systems.
- (2) Compliance demonstration records for coating operations.

For any coating operation subject to paragraph (D) of this rule, the owner or operator shall maintain the following records:

- (a) For each coating in use at the facility, the following:
 - (i) The name and VOC content as received and as applied.
 - (ii) The type of coating, as identified in paragraphs (D)(1)(a) and (D)(1)(b) of this rule.
 - (iii) Where applicable, identification of the coating as designated for control pursuant to paragraph (D)(2) of this rule or exempted pursuant to paragraphs (D)(3)(a) to (D)(3)(e) of this rule.
- (b) All data, calculations, and test results (including USEPA method 24 results) used in determining the VOC content of each coating, expressed in pounds of VOC per gallon of coating, excluding water and exempt solvents, as applied.
- (c) The amount (gallons) of each coating used each month at the facility.
- (d) For any coating operation controlled by a VOC emission control system, the following:
 - (i) Identification of the coating line.
 - (ii) Documentation on the overall control efficiency of the VOC emission control system and the control efficiency of any thermal or catalytic oxidizer within the VOC emission control system, including design estimates and the results of compliance tests conducted pursuant to paragraphs (F)(2), (F)(3), and (I) of this rule.
 - (iii) For any coating that is controlled by the VOC emission control system, the name of the coating, the dates (or time periods) of control, and the amount (gallons) of such coating controlled each month.
- (e) Records pertaining to a rolling thirty-day average VOC content for a dip coater, the following:
 - (i) For each day of operation, the gallons of each material (coating and thinner) added to the dip coater reservoir.
 - (ii) The VOC content (in pounds of VOC per gallon), volume fraction VOC, and volume fraction solids for each material added to the dip coater reservoir.

- (iii) For each day of operation, the rolling thirty-day average VOC content in pounds of VOC per gallon of coating, excluding water and exempt solvent, as applied, as determined in accordance with paragraph (H)(2) of this rule.
- (f) Records pertaining to the low usage coating exemption (for coating formulations elected by the owner or operator as being subject to the low usage restrictions under paragraph (D)(3)(e) of this rule), the following:
- (i) The name of each separate coating formulation.
 - (ii) The amount (gallons) used during the month at the facility for each separate coating formulation.
 - (iii) The total amount (gallons) used during the calendar year at the facility for each separate coating formulation and for all such coatings formulations combined.
- (3) Compliance demonstration records for cleaning operations.

For cleaning operations subject to paragraph (E) of this rule, the owner or operator shall maintain the following records, where appropriate:

- (a) The name, vapor pressure (i.e., VOC composite vapor pressure), and documentation showing the composition of each cleaning solvent used.
- (b) A listing of cleaning operations in which each cleaning solvent is used.
- (c) For each cleaning solvent used in hand wipe cleaning operations that complies with the water composition requirement under the paragraph (E)(1)(a)(i) of this rule or the VOC composite vapor pressure requirement under paragraph (E)(1)(a)(ii) of this rule, the following:
 - (i) The name of each cleaning solvent used.
 - (ii) All data and calculations that demonstrate the cleaning solvent complies with either the water composition requirement or VOC composite vapor pressure requirement.
 - (iii) The amount (gallons) of each cleaning solvent used each year, as determined from facility purchase or usage records.

- (d) For each cleaning solvent used in hand wipe cleaning operations that does not comply with the requirements under paragraph (E)(1)(a) of this rule, but is exempted under paragraph (E)(1)(b) of this rule, the following:
 - (i) The name of each cleaning solvent used.
 - (ii) A list of the exempted hand wipe cleaning operations set forth in paragraph (E)(1)(b) of this rule in which each cleaning solvent is used.
 - (iii) The amount (gallons) of each cleaning solvent used each year, as determined from facility purchase or usage records.
 - (e) For each cleaning solvent used in flush cleaning operations that complies with the water composition requirement under paragraph (E)(3)(b)(i) or (E)(3)(b)(iii) of this rule or the VOC composite vapor pressure requirement under paragraph (E)(3)(b)(ii) of this rule, the following:
 - (i) The name of each cleaning solvent used.
 - (ii) All data and calculations that demonstrate the cleaning solvent complies with either the water composition requirement or VOC composite vapor pressure requirement.
 - (iii) The amount (gallons) of each cleaning solvent used each year, as determined from facility purchase or usage records.
 - (f) For any enclosed spray gun cleaner subject to paragraph (E)(2)(a)(i) of this rule, the following:
 - (i) A record or schedule of visual inspections of the seals and other potential sources of leaks.
 - (ii) For each leak found, the following:
 - (a) Identification of the type of leak.
 - (b) Date leak was discovered.
 - (c) Date leak was repaired.
- (4) Monitoring records for VOC emission control systems.

For a VOC emission control system subject to paragraph (G) of this rule, the owner or operator shall maintain the same monitoring records as specified under paragraph (K)(5) of rule 3745-21-15 of the Administrative Code.

(K) Reporting.

(1) (General) The provisions under paragraph (K) of this rule describe the contents of reports and identify the reporting dates for the following reports:

- (a) Initial compliance status.
- (b) Semiannual compliance status.

(2) Initial compliance status report.

The owner or operator of an aerospace manufacturing or rework facility subject to this rule shall submit an initial compliance status report within sixty calendar days after the compliance date specified in paragraph (F) of this rule as follows:

- (a) For any coating operation subject to the VOC content limit of paragraph (D)(1) of this rule, the owner or operator shall state in the initial compliance status report the type of coating, the VOC content limit for the coating, and that only coatings meeting the applicable VOC content limit are to be employed, unless otherwise controlled pursuant to paragraph (D)(2) of this rule or exempted pursuant to paragraph (D)(3) of this rule.
- (b) For any coating that is applied by means of a dip coater, that is subject to the VOC content limit of paragraph (D)(1) of this rule, and that complies by the procedures of paragraph (H)(2) of this rule pertaining to a rolling thirty-day average VOC content, the owner or operator shall state in the initial compliance status report that only coatings meeting the applicable VOC content limit, as determined by the procedures of paragraph (H)(2) of this rule, are to be employed.
- (c) For any coating operation that is equipped with a VOC emission control system to comply with paragraph (D)(2) of this rule, the owner or operator shall submit the following in the initial compliance status report:
 - (i) Information on the types of coatings to be controlled.
 - (ii) Identification and description of each monitoring device employed to comply with paragraph (G) of this rule.

- (iii) The results of compliance tests conducted pursuant to paragraph (I) of this rule to determine the overall control efficiency of the VOC emission control system and the control efficiency of any thermal or catalytic oxidizer within the VOC emission control system.
- (iv) A complete test report for any compliance tests of the VOC emission control system.

A complete test report shall include a brief process description, sampling site description, description of sampling and analysis procedures and any modifications to standard procedures, quality assurance procedures, record of operating conditions during the test, record of preparation of standards, record of calibrations, raw data sheets for field sampling, raw data sheets for field and laboratory analyses, documentation of calculations, and any other information required by the test method.

- (v) For any compliance tests of the VOC emission control system, the compliance test monitoring data recorded pursuant to paragraph (I) (2) of this rule, including the operating parameter values established for any monitoring device.
- (d) For cleaning operations subject to paragraph (E) of this rule, the owner or operator shall submit the following in the initial compliance status report:
- (i) A description of the types of cleaning operations.
 - (ii) A listing of the cleaning solvents being employed in each cleaning operation.
 - (iii) A statement that all cleaning operations are to comply with the applicable requirements under paragraph (E) of this rule.

(3) Semiannual compliance status reports.

The owner or operator of an aerospace manufacturing or rework facility subject to this rule shall submit semiannual compliance status reports no later than thirty calendar days after the end of each six-month period to the appropriate Ohio EPA district office or local air agency. The first report shall be submitted no later than thirty calendar days after the end of the first six-month period following the compliance date. Subsequent reports shall be submitted no later than thirty calendar days after the end of each six-month period following the first report or no later than thirty calendar days after the end of each six-month period otherwise established within a permit issued for the aerospace

manufacturing or rework facility. For each semiannual compliance status report, the owner or operator shall submit the following information for the six-month period covered by the report:

- (a) For any coating operation subject to paragraph (D)(1) of this rule, the owner or operator shall state in the semiannual compliance status report any changes to the previous reporting of the types of coatings and the VOC content limits for the coatings.
- (b) For any coating that is applied by means of a dip coater and that is subject to the VOC content limit of paragraph (D)(1) of this rule, the owner or operator shall state in the semiannual compliance status report any changes to the previous reporting of procedures for determining the VOC content of the coating.
- (c) For any VOC emission control system employed to meet paragraph (D)(2) of this rule, any changes to monitoring devices previously reported and required under paragraph (G) of this rule.
- (d) If any subsequent compliance tests of the VOC emission control system are conducted during the semiannual reporting period after the initial compliance status report has been submitted, the semiannual compliance status report shall include the results of each compliance test, a complete test report, and the compliance test monitoring data as described under paragraphs (K)(2)(c)(iii) to (K)(2)(c)(v) of this rule.
- (e) For cleaning operations subject to paragraph (E) of this rule, the owner or operator shall submit in the semiannual compliance status report any changes to the previous reporting of the description of the types of cleaning operations and the listing of the cleaning solvents employed in each cleaning operation.
- (f) Compliance certification for semiannual reporting period.

The owner or operator shall submit with the semiannual compliance status report, the following compliance certifications, where applicable:

- (i) For any coating that is subject to a VOC content limit of paragraph (D)(1) of this rule, the compliance certification shall state that only coatings which comply with the applicable VOC content limit have been used each operating day in the semiannual reporting period, or should otherwise identify the periods of use of coatings that did not comply, the reasons for such use of noncompliant coatings, and

the amounts and VOC contents of each such noncompliant coating used. Use of a noncompliant coating is a separate violation for each day the noncompliant coating is used.

- (ii) For any coating that is applied by means of a dip coater, that is subject to a VOC content limit of paragraph (D)(1) of this rule, and that complies by the procedures of paragraph (H)(2) of this rule, the compliance certification shall state that only coatings which comply with the applicable VOC content limit, as determined by the procedures of paragraph (H)(2) of this rule, have been used each operating day in the semiannual reporting period, or should otherwise identify the periods of use of coatings that did not comply, the reasons for the use of such noncompliant coatings, and the amounts and VOC contents of each such noncompliant coating used. Use of a noncompliant coating is a separate violation for each day the noncompliant coating is used.
- (iii) For any coating operation that is equipped with a VOC emission control system to comply with paragraph (D)(3) of this rule:
 - (a) The compliance certification shall state that the three-hour block averages of the monitoring parameters recorded pursuant to paragraph (K)(5) of this rule had complied with the operating limits (operating parameter values) for the monitoring parameters established under paragraph (J)(2) of this rule during of all periods of operation of the coating operation in the semiannual reporting period; or should otherwise identify the times and durations of all periods of noncompliance and the reasons for noncompliance.
 - (b) The compliance certification shall identify the times and durations of all periods during coating operation or control operation when the monitoring device is not working, as recorded pursuant to paragraph (J)(3) of this rule and paragraph (K)(5) of rule 3745-21-15 of the Administrative Code.
 - (c) For any capture system bypass line, the compliance certification shall identify the times and durations of all periods in which the captured VOC emissions were discharged to atmosphere instead of a control device, as recorded pursuant to paragraph (J)(3) of this rule and paragraph (K)(5)(f) of rule

3745-21-15 of the Administrative Code, and the reasons for the discharges to atmosphere.

- (d) The compliance certification shall state that the overall reduction and control of VOC emissions, based on the most recent compliance test conducted in accordance with paragraph (I) of this rule, has met paragraph (D)(2) of this rule for each coating designated for control during the semiannual reporting period, or should otherwise identify the periods of noncompliance and the reasons for noncompliance.
- (iv) For coatings subject to the low usage exemption under paragraph (D)(3)(e) of this rule, the compliance certification shall state that the usage of these coatings during the semiannual reporting period did not exceed the annual usage restrictions for the calendar year, or should otherwise identify for each noncompliance of any annual usage restriction the reasons for the noncompliant usage and the amounts and VOC contents of the coatings used in the noncompliant usage.
- (v) For cleaning operations subject to paragraph (E) of this rule, the compliance certification shall identify the following for the semiannual reporting period:

 - (a) Any instance where a noncompliant cleaning solvent is used for a hand wipe cleaning operation that is not exempted under paragraph (E)(1)(b) of this rule.
 - (b) Any instance where a noncompliant spray gun cleaning method is used.
 - (c) Any instance where a leaking enclosed spray gun cleaner remains unrepaired and in use for more than fifteen days.
 - (d) Any other instance of noncompliance with a requirement under paragraph (E) of this rule.
 - (e) If the cleaning operations have been in compliance for the semiannual reporting period, a statement that the cleaning operations have been in compliance with the applicable requirements.

- (vi) The compliance certification shall identify and describe any corrective actions considered and implemented for any noncompliance being reported in the compliance certification.
- (vii) The compliance certification shall be signed by the responsible official of a Title V facility, as defined in rule 3745-77-01 of the Administrative Code or the signatory authority under rule 3745-31-02 of the Administrative Code for a facility that is not Title V, that owns or operates the aerospace manufacturing or rework facility.

(L) Applicability notification and permit application.

- (1) The owner or operator of an aerospace manufacturing or rework facility that is subject to this rule, is located in located in Ashtabula, Cuyahoga, Geauga, Lake, Lorain, Medina, Portage, or Summit county, and has an initial startup of coating or cleaning operations before August 25, 2008 shall notify the appropriate Ohio EPA district office or local air agency in writing that the facility is subject to this rule not later than October 24, 2008, providing the information specified in paragraph (L)(5) of this rule.
- (2) The owner or operator of an aerospace manufacturing or rework facility that is subject to this rule, is located in Ashtabula, Cuyahoga, Geauga, Lake, Lorain, Medina, Portage, or Summit county, and has an initial startup of coating or cleaning operations on or after August 25, 2008 shall notify the appropriate Ohio EPA district office or local air agency in writing that the facility is subject to this rule not later than either the date of initial startup of the facility's coating or cleaning operations or October 24, 2008 (whichever is later), providing the information specified in paragraph (L)(5) of this rule. The application for a permit-to-install under rule 3745-31-02 of the Administrative Code may be used to fulfill the notification requirements of this paragraph.
- (3) The owner or operator of an aerospace manufacturing or rework facility that is subject to this rule, is located in Butler, Clermont, Hamilton or Warren county, and has an initial startup of coating or cleaning operations before the effective date of this rule shall notify the appropriate Ohio EPA district office or local air agency in writing that the facility is subject to this rule not later than sixty days after the effective date of this rule, providing the information specified in paragraph (L)(5) of this rule.
- (4) The owner or operator of an aerospace manufacturing or rework facility that is subject to this rule, is located in Butler, Clermont, Hamilton or Warren county, and has an initial startup of coating or cleaning operations on or after the

effective date of this rule shall notify the appropriate Ohio EPA district office or local air agency in writing that the facility is subject to this rule not later than either the date of initial startup of the facility's coating or cleaning operations or sixty days after the effective date of this rule (whichever is later), providing the information specified in paragraph (L)(5) of this rule. The application for a permit-to-install under rule 3745-31-02 of the Administrative Code may be used to fulfill the notification requirements of this paragraph.

~~(1)(5) The owner or operator of an aerospace manufacturing or rework facility that is subject to this rule and that has an initial startup of coating or cleaning operations before August 25, 2008 shall notify the appropriate Ohio EPA district office or local air agency in writing that the facility is subject to this rule. The notification, which shall be submitted not later than October 24, 2008, required in paragraphs (L)(1) to (L)(4) fo this rule shall provide the following information:~~

- (a) Name and address of the owner or operator.
- (b) Address (i.e., physical location) of the facility.
- (c) Equipment description and Ohio EPA application number (if assigned) of any coating or cleaning operations.
- (d) Identification of the applicable requirements, the means of compliance, and the compliance date for the coating and cleaning operations under this rule.
- (e) An application for an operating permit or an application for a modification to an operating permit in accordance with Chapter 3745-77 of the Administrative Code (for sources subject to the Title V permit program) or an application for a permit-to-install and operate or an application for a modification to a permit-to-install and operate in accordance with Chapter 3745-31 of the Administrative Code (for sources not subject to the Title V permit program) for each subject process that meets one of the following:
 - (i) The process does not possess an effective operating permit or permit-to-install and operate.
 - (ii) The process possesses an effective operating permit or permit-to-install and operate and the owner or operator cannot certify in writing to the director that such subject process is in compliance with this rule. An application for an operating permit or permit-to-

install and operate is not required provided the subject process is operating under an effective permit and certifies compliance. Such certification shall include all compliance certification requirements under paragraph (K)(2) of this rule.

~~(2) The owner or operator of an aerospace manufacturing or rework facility that is subject to this rule and that has an initial startup of coating or cleaning operations on or after August 25, 2008 shall notify the appropriate Ohio EPA district office or local air agency in writing that the facility is subject to this rule. The notification, which shall be submitted not later than either the date of initial startup of the facility's coating or cleaning operations or October 24, 2008 (whichever is later), shall provide the information listed under paragraph (L)(1) of this rule. The application for a permit to install under rule 3745-31-02 of the Administrative Code may be used to fulfill the notification requirements of this paragraph.~~

Effective: 3/27/2022
Five Year Review (FYR) Dates: 11/29/2021 and 11/29/2026

CERTIFIED ELECTRONICALLY

Certification

03/17/2022

Date

Promulgated Under: 119.03
Statutory Authority: 3704.03(E)
Rule Amplifies: 3704.03(A), 3704.03(E)
Prior Effective Dates: 08/25/2008, 10/15/2015

3745-21-20

Control of volatile organic emissions from shipbuilding and ship repair operations (marine coatings).

[Comment: For dates and availability of non-regulatory government publications, publications of recognized organizations and associations, federal rules, and federal statutory provisions referenced in this rule, see paragraph (JJ) of rule 3745-21-01 of the Administrative Code titled "referenced materials."]

(A) Applicability.

(1) Except as otherwise provided in paragraph (A)(2) of this rule, this rule shall apply to any facility that meets both of the following conditions:

(a) The facility has shipbuilding or ship repair operations.

(b) The facility is located in Ashtabula, Butler, Clermont, Cuyahoga, Geauga, Hamilton, Lake, Lorain, Medina, Portage, ~~or~~ Summit, or Warren county.

(2) Excluded from this rule is any facility that has the potential to emit for VOC of less than 25.0 tons per year for all shipbuilding and ship repair operations combined. However, this exclusion is not available for any facility that has, or once had, the potential to emit for VOC of equal to or greater than 25.0 tons per year for all shipbuilding and ship repair operations combined on or after the facility's compliance date specified under paragraph (F) of this rule.

(B) Definitions.

The definitions applicable to this rule are contained in paragraphs (B) and (BB) of rule 3745-21-01 of the Administrative Code.

(C) Overall requirements for shipbuilding or ship repair operations.

Any owner or operator of shipbuilding or ship repair operations that are subject to this rule shall comply with paragraphs (D) to (L) of this rule.

(D) VOC emission limitations for marine coatings.

(1) Except as otherwise provided in paragraphs (D)(2) and (D)(3) of this rule, a person shall not apply any marine coating that contains VOC in excess of the VOC content limits specified in the following table:

VOC content limits for marine coatings^a.

Category of Marine Coating	Pounds of VOC per gallon of coating,	Pounds of VOC per gallon of solids,	Pounds of VOC per gallon of solids,

	excluding water and exempt solvents, as applied	as applied, if the temperature is equal to or greater than forty degrees Fahrenheit	as applied, if the temperature is less than forty degrees Fahrenheit ^b
General use coating	2.8	4.8	6.1
Specialty coating:			
Air flask coating	2.8	4.8	6.1
Antenna coating	4.4	12.0	N/A
Antifoulant coating	3.3	6.4	8.1
Heat resistant coating	3.5	7.0	8.9
High-gloss coating	3.5	7.0	8.9
High-temperature coating	4.2	10.3	13.3
Inorganic zinc (high-build) coating	2.8	4.8	6.1
Interior coating	2.8	4.8	6.1
Military exterior coating	2.8	4.8	6.1
Mist coating	5.1	18.7	N/A
Navigational aids coating	4.6	13.3	N/A
Nonskid coating	2.8	4.8	6.1
Nuclear coating	3.5	7.0	8.9
Organic zinc coating	3.0	5.3	6.7
Pretreatment coating	6.5	92.6	N/A

Repair and maintenance thermoplastic coating	4.6	13.3	N/A
Rubber camouflage coating	2.8	4.8	6.1
Sealant coating for thermal spray aluminum	5.1	18.7	N/A
Special marking coating	4.1	9.8	N/A
Tack coating	5.1	18.7	N/A
Undersea weapons systems coating	2.8	4.8	6.1
Weld-through preconstruction primer	5.4	24.1	N/A

^a The limits are expressed in two sets of equivalent units in the second and third columns of the table. Either set of limits may be used for the compliance procedure described in paragraph (H)(4)(a) of this rule, but only the limits expressed in units of pounds of VOC per gallon of solids (non-volatiles) shall be used for the compliance procedures described in paragraphs (H)(4)(b), (H)(4)(c), and (H)(5) of this rule.

^b The limits in the fourth column of the table apply during cold-weather time periods, as defined under paragraph (BB) of rule 3745-21-01 of the Administrative Code. Cold-weather allowances are not given to coatings in categories that permit more than a forty per cent VOC content by volume. Such coatings are subject to the limits in second and third columns of the table in this rule regardless of weather conditions.

(2) VOC emission control system for a coating.

In lieu of the VOC content limit for any coating subject to paragraph (D)(1) of this rule, a VOC emission control system shall be used that achieves, for each coating employed and designated for control, an overall reduction of VOC

emissions that is equal to or greater than the required overall control efficiency determined in accordance with paragraph (H)(5) of this rule. Also, if the VOC emission control system includes a thermal or catalytic oxidizer, the control efficiency of the thermal or catalytic oxidizer for VOC emissions shall be at least ninety per cent by weight.

(3) The following coating applications are exempt from the VOC content limits listed in paragraph (D)(1) of this rule:

(a) Aerosol coatings.

(b) Unsaturated polyester resin (i.e., fiberglass lay-up) coatings (however, coatings applied to suitably prepared fiberglass surfaces for protective or decorative purposes are subject to this rule).

(c) Coatings that meet the following low usage restrictions at the facility:

(i) Total usage of each separate coating formulation does not exceed fifty gallons per rolling twelve month period.

(ii) Total usage of all such coating formulations combined does not exceed two hundred fifty gallons per rolling twelve month period.

(E) Handling and transfer of marine coatings and thinners.

Any owner or operator of shipbuilding or ship repair operations shall ensure the following:

(1) All handling and transfer of marine coatings and thinners to and from containers, tanks, vats, drums, and piping systems is conducted in a manner that minimizes spills.

(2) All containers, tanks, vats, drums, and piping systems are free of cracks, holes, and other defects and remain closed unless materials are being added to or removed from them.

(F) Compliance dates.

(1) Except where otherwise specified within this rule, any owner or operator of shipbuilding or ship repair operations that are subject to this rule shall comply with this rule by no later than the following dates:

(a) For shipbuilding or ship repair operations located in Ashtabula, Cuyahoga, Geauga, Lake, Lorain, Medina, Portage, or Summit county for which

installation commenced before August 25, 2008, the compliance date is either August 25, 2009 or the date of initial startup of the shipbuilding or ship repair operations, whichever is later.

(b) For shipbuilding or ship repair operations located in Ashtabula, Cuyahoga, Geauga, Lake, Lorain, Medina, Portage, or Summit county for which installation commenced on or after August 25, 2008, the compliance date is the date of initial startup of the shipbuilding or ship repair operations.

(c) For shipbuilding or ship repair operations located in Butler, Clermont, Hamilton or Warren county for which installation commenced before the effective date of this rule, the compliance date is either March 1, 2023 or the date of initial startup of the shipbuilding or ship repair operations, whichever is later.

(d) For shipbuilding or ship repair operations located in Butler, Clermont, Hamilton or Warren county for which installation commenced on or after the effective date of this rule, the compliance date is the date of initial startup of the shipbuilding or ship repair operations.

(2) For a VOC emission control system that is used for a coating to comply with paragraph (D)(2) of this rule, the owner or operator shall demonstrate the overall control efficiency of the VOC emission control system and the control efficiency of any thermal or catalytic oxidizer within the VOC emission control system by testing the coating operation and the VOC emission control system in accordance with paragraph (I) of this rule within ninety days after the compliance date of the shipbuilding or ship repair operations.

(3) Additional testing of the coating operation and the VOC emission control system in accordance with paragraph (I) of this rule may be required by the director to ensure continued compliance.

(G) Monitoring of a VOC emission control system.

For a VOC emission control system that is used for a coating to comply with paragraph (D)(2) of this rule, the owner or operator shall meet the same monitoring requirements as contained in paragraph (H) of rule 3745-21-15 of the Administrative Code.

(H) Procedures for the VOC content and solids content of a coating and the determination of required overall control efficiency for controlled coatings.

(1) The VOC content and solids content of a coating shall be determined by the owner or operator in accordance with paragraph (B) of rule 3745-21-10 of

the Administrative Code, wherein formulation data or USEPA method 24 procedures (which include various ASTM measurement methods) may be employed.

(2) For each batch of coating that is received by the facility, the owner or operator shall do the following:

(a) Determine the coating category and the applicable VOC limit as specified under in paragraph (D)(1) of this rule.

(b) Certify the as supplied VOC content of the batch of coating. The owner or operator may use a certification supplied by the manufacturer for the batch, although the owner or operator retains liability should subsequent testing reveal a violation. If the owner or operator performs the certification testing, only one of the containers in which the batch of coating was received is required to be tested.

(3) In lieu of testing each batch of coating, as applied, the owner or operator may determine compliance with the VOC content limits using any combination of the procedures described in paragraphs (H)(4)(a) to (H)(4)(c) of this rule. The procedure used for each coating shall be determined and documented prior to application. However, the results of any compliance demonstration conducted by the owner or operator or any regulatory agency using USEPA method 24 shall take precedence over the results using the procedures in paragraphs (H)(4)(a), (H)(4)(b), and (H)(4)(c) of this rule.

(4) Compliance procedures for as applied VOC content of coatings.

(a) Coatings to which thinning solvent will not be applied.

For coatings to which thinning solvent (or any other material) will not be added under any circumstance or to which only water is added, the owner or operator shall comply as follows:

(i) Certify the as applied VOC content of each batch of coating.

(ii) Notify the persons responsible for applying the coating that no thinning solvent may be added to the coating by affixing a label to each container of coating in the batch or through another means.

(iii) If the certified as applied VOC content of each batch of coating used during any day is less than or equal to the applicable VOC content limit in paragraph (D)(1) of this rule (either in terms of pounds of VOC per gallon of coating, excluding water and exempt

solvents, or pounds of VOC per gallon of solids), then compliance is demonstrated for each day, unless non compliance is determined using USEPA method 24.

- (b) Coatings to which thinning solvent will be added (coating-by-coating compliance).

For a coating to which thinning solvent is routinely or sometimes added, the owner or operator shall comply as follows:

- (i) Prior to the first application of each batch, designate a single thinner for the coating and calculate the maximum allowable thinning ratio (or ratios, if the coating shall comply with the cold-weather limits in addition to the other limits specified in paragraph (D)(1) of this rule for each batch as follows:

$$R = \frac{(V_s)(VOC_{limit}) - m_{VOC}}{D_{th}} \quad \text{Equation 1}$$

where:

R = Maximum allowable thinning ratio for a given batch (gallons of thinner per gallon of coating as supplied).

V_s = Volume fraction of solids in the batch as supplied (gallon of solids per gallon of coating as supplied).

VOC_{limit} = Maximum allowable as-applied VOC content of the coating (pound VOC per gallon of solids).

m_{VOC} = VOC content of the batch as supplied [pounds VOC (including cure volatiles) per gallon of coating (including water and exempt compounds) as supplied].

D_{th} = Density of the thinner (pounds per gallon).

If V_S is not supplied directly by the coating manufacturer, the owner or operator shall determine V_S as follows:

$$V_S = 1 - \frac{m_{\text{volatiles}}}{D_{\text{avg}}} \quad \text{Equation 2}$$

where:

$m_{\text{volatiles}}$ = Total volatiles in the batch, including VOC, water, and exempt compounds (pounds of volatiles per gallon of coating).

D_{avg} = Average density of volatiles in the batch (pounds per gallon).

- (ii) Prior to the first application of each batch, notify painters and other persons, as necessary, of the designated thinner and maximum allowable thinning ratio for each batch of the coating by affixing a label to each container of coating or through another means.
- (iii) By the fifteenth day of each calendar month, determine the volume of each batch of the coating used, as supplied, during the previous month.
- (iv) By the fifteenth day of each calendar month, determine the total allowable volume of thinner for the coating used during the previous month as follows:

$$V_{\text{th}} = \sum_{i=1}^n (R \times V_b)_i + \sum_{i=1}^n (R_{\text{cold}} \times V_{b-\text{cold}})_i \quad \text{Equation 3}$$

Where:

V_{th} = Total allowable volume of thinner for the previous month (gallons of thinner).

V_b = Volume of each batch, as supplied and before being thinned, used during non-cold-weather days of the previous month (gallons of coating as supplied).

R_{cold} = Maximum allowable thinning ratio for each batch used during cold-weather days (gallons of thinner per gallon of coating as supplied).

V_{b-cold} = Volume of each batch, as supplied and before being thinned, used during cold-weather days of the previous month (gallons of coating as supplied).

i = Each batch of coating.

n = Total number of batches of the coating.

- (v) By the fifteenth day of each calendar month, determine the volume of thinner actually used with the coating during the previous month.
- (vi) If the volume of thinner actually used with the coating [paragraph (H)(4)(b)(v) of this rule] is less than or equal to the total allowable volume of thinner for the coating [paragraph (H)(4)(b)(iv) of this rule], then compliance is demonstrated for the coating for each operating day of the previous month, unless a violation is revealed using USEPA method 24.

- (c) Coatings to which the same thinning solvent will be added (group compliance).

For coatings to which the same thinning solvent (or other material) is routinely or sometimes added, the owner or operator shall comply as follows:

- (i) Designate a single thinner to be added to each coating during the month and "group" coatings according to their designated thinner.
- (ii) Prior to the first application of each batch, calculate the maximum allowable thinning ratio (or ratios, if the coating shall comply with the cold-weather limits in addition to the other limits specified in paragraph (D)(1) of this rule) for each batch of coating in the group using the equations in paragraph (H)(4)(b) of this rule.

- (iii) Prior to the first application of each "batch," notify painters and other persons, as necessary, of the designated thinner and maximum allowable thinning ratio for each batch in the group by affixing a label to each container of coating or through another means described in the implementation plan specified in paragraph (J)(2)(a) of this rule.
 - (iv) By the fifteenth day of each calendar month, determine the volume of each batch of the group used, as supplied, during the previous month.
 - (v) By the fifteenth day of each calendar month, determine the total allowable volume of thinner for the group for the previous month using equation 3 in paragraph (H)(4)(b)(iv) of this rule.
 - (vi) By the fifteenth day of each calendar month, determine the volume of thinner actually used with the group during the previous month.
 - (vii) If the volume of thinner actually used with the group [paragraph (H)(4)(c)(vi) of this rule] is less than or equal to the total allowable volume of thinner for the group [paragraph (H)(4)(c)(v) of this rule], then compliance is demonstrated for the group for each operating day of the previous month, unless a violation is revealed using USEPA method 24.
- (d) A violation revealed through any approved test method shall result in a one-day violation for enforcement purposes. A violation revealed through the recordkeeping procedures described in paragraphs (H)(4)(c)(i) to (H)(4)(c)(iii) of this rule shall result in a thirty-day violation for enforcement purposes, unless the owner or operator provides sufficient data to demonstrate the specific days during which noncompliant coatings were applied.

(5) Determination of required overall control efficiency for controlled coatings.

For a VOC emission control system that is used to comply with paragraph (D)(2) of this rule, the overall reduction of VOC emissions, that is, the required overall control efficiency (R), expressed in per cent by weight, shall be determined as follows for each coating designated for control:

$$R = [(C-L)/C](100)$$

Where:

C = VOC content of the coating designated for control, in pounds of VOC per pound of solids, as applied; and

L = VOC content limit under paragraph (D)(1) of this rule for the coating designated for control, in pounds of VOC per pound of solids, as applied.

(I) Compliance tests for VOC emission control systems.

- (1) For a VOC emission control system used to comply with paragraph (D)(2) of this rule, the owner or operator shall conduct a compliance test to determine the capture efficiency of the capture system, the control efficiency of the control device (or each control device if a combination of control devices is employed), and the overall control efficiency of the VOC emission control system in accordance with paragraph (C) of rule 3745-21-10 of the Administrative Code wherein USEPA method 25 or 25A shall be used for determining the concentration of VOC in a gas stream.
- (2) During the compliance test described in paragraph (I)(1) of this rule that demonstrates compliance, the owner or operator shall establish the operating limits (operating parameter values) for the monitoring devices required under paragraph (G) of this rule by following paragraph (J)(2) of rule 3745-21-15 of the Administrative Code.

(J) Recordkeeping.

- (1) (General) All records specified under paragraph (J) of this rule shall be retained by the owner or operator for a period of not less than five years and shall be made available to the director or any authorized representative of the director for review during normal business hours. The following types of records are to be maintained by the owner or operator of shipbuilding or ship repair operations subject to this rule:
 - (a) Compliance demonstration records for coating operations.
 - (b) Compliance demonstration records for the handling and transfer of marine coatings and thinners.
 - (c) Monitoring records for VOC emission control systems.
- (2) Compliance demonstration records for coating operations.

For any coating operation subject to paragraph (D)(1) of this rule, the owner or operator shall compile the following records on a monthly basis:

- (a) A copy of an implementation plan that addresses the coating compliance procedures under paragraph (H) of this rule and the recordkeeping procedures under paragraph (J) of this rule, including the procedures for gathering the necessary data and making the necessary calculations.
 - (b) For coating formulations elected by the owner or operator as being subject to the low usage restrictions under paragraph (D)(3)(c) of this rule, the following:
 - (i) The identification and gallons used during the month for each separate coating.
 - (ii) The total gallons used during the current rolling twelve month period (this month plus the previous eleven months) for each separate coating.
 - (iii) The total gallons used during the current rolling twelve month period (this month plus the previous eleven months) for all such coatings combined.
 - (c) Identification of the coatings used, their appropriate coating categories, and the applicable VOC limit.
 - (d) Certification of the as-supplied VOC content of each batch of coating.
 - (e) A determination of whether containers meet the requirements as described in paragraph (E)(2) of this rule.
 - (f) The results of any USEPA method 24 measurement test or approved alternative measurement test conducted on individual containers of coating, as applied.
 - (g) The records specified under paragraphs (J)(3) and (J)(4) of this rule, where appropriate.
- (3) The records required by paragraph (J)(2) of this rule shall include the following additional information, as determined by the compliance procedures described in paragraph (H)(4) of this rule that each owner or operator followed:
- (a) Coatings to which thinning solvent will not be added.

The records maintained by an owner or operator demonstrating compliance using the procedure described in paragraph (H)(4)(a) of this rule shall contain the following information:

- (i) Certification of the as-applied VOC content of each batch of coating.
 - (ii) The volume of each coating applied.
- (b) For coatings to which thinning solvent will be added for coating-by-coating compliance.

The records maintained by an owner or operator demonstrating compliance using the procedure described in paragraph (H)(4)(b) shall contain the following information:

- (i) The density and mass fraction of water and exempt compounds of each thinner and the volume fraction of solids (nonvolatiles) in each batch, including any calculations.
 - (ii) The maximum allowable thinning ratio (or ratios, if the coating operation complies with the cold-weather limits in addition to the other limits specified in paragraph (D)(1) of this rule for each batch of coating, including calculations.
 - (iii) If an owner or operator chooses to comply with the cold-weather limits, the dates and times during which the ambient temperature at the coating operation was below forty degrees Fahrenheit (4.5 degrees Celsius) at the time the coating was applied and the volume used of each batch of the coating, as supplied, during these dates.
 - (iv) The volume used of each batch of the coating, as supplied.
 - (v) The total allowable volume of thinner for each coating, including calculations.
 - (vi) The actual volume of thinner used for each coating.
- (c) Coatings to which the same thinning solvent will be added for group compliance.

The records maintained by an owner or operator demonstrating compliance using the procedure described in paragraph (H)(4)(c) of this rule shall contain the following information:

- (i) The density and mass fraction of water and exempt compounds of each thinner and the volume fraction of solids in each batch, including any calculations.

- (ii) The maximum allowable thinning ratio (or ratios, if the coating operation complies with the cold-weather limits in addition to the other limits specified in paragraph (D)(1) of this rule) for each batch of coating, including calculations.
 - (iii) If an owner or operator chooses to comply with the cold-weather limits, the dates and times during which the ambient temperature at the coating operation was below forty degrees Fahrenheit (4.5 degrees Celsius) at the time the coating was applied and the volume used of each batch in the group, as supplied, during these dates.
 - (iv) Identification of each group of coatings and their designated thinners.
 - (v) The volume used of each batch of coating in the group, as supplied.
 - (vi) The total allowable volume of thinner for the group, including calculations.
 - (vii) The actual volume of thinner used for the group.
- (4) For any coating operation controlled by a VOC emission control system to meet paragraph (D)(2) of this rule, the owner or operator shall maintain the following records:
- (a) Documentation on the overall control efficiency of the VOC emission control system and the control efficiency of any thermal or catalytic oxidizer within the VOC emission control system, including design estimates and the results of compliance tests conducted pursuant to paragraphs (F)(2), (F)(3), and (I) of this rule.
 - (b) The following records on a monthly basis for any coating controlled by the VOC emission control system:
 - (i) The identification of the coating, and the dates (or time periods) of control.
 - (ii) For controlled coatings to which the owner or operator does not add thinning solvents, the owner or operator shall record the certification of the as supplied and as applied VOC content of each batch and the volume of each coating applied.
 - (iii) For controlled coatings to which the owner or operator adds thinning solvent on a coating-by-coating basis, the owner or operator shall

record all of the information required to be recorded by paragraph (J)(3)(b) of this rule.

(iv) For controlled coatings to which the owner or operator adds thinning solvent on a group basis, the owner or operator shall record all of the information required to be recorded by paragraph (J)(3)(c) of this rule.

(c) The monitoring records specified under paragraph (J)(6) of this rule.

(5) Compliance demonstration records for the handling and transfer of marine coatings and thinners.

For the handling and transfer of marine coatings and thinners, the owner or operator shall maintain the following records on a monthly basis:

(a) A copy of an implementation plan that addresses the procedures for ensuring compliance with the requirements for handling and transfer of marine coatings and thinners under paragraph (E) of this rule.

(b) A determination on whether the requirements as described in paragraph (E) (2) of this rule are being met.

(6) Monitoring records for VOC emission control systems.

For a VOC emission control system that is employed to meet paragraph (D)(2) of this rule, the owner or operator shall maintain the same monitoring records as specified under paragraph (K)(5) of rule 3745-21-15 of the Administrative Code.

(K) Reporting.

(1) (General) The provisions under paragraph (K) of this rule describe the contents of reports and identify the reporting dates for the following reports:

(a) Initial compliance status report.

(b) Semiannual compliance status reports.

(2) Initial compliance status report.

The owner or operator of shipbuilding or ship repair operations subject to this rule shall submit an initial compliance status report within sixty calendar days after the compliance date specified in paragraph (F) of this rule as follows:

- (a) For any coating operation subject to the VOC content limit of paragraph (D) (1) of this rule, the owner or operator shall state in the initial compliance status report the type of coating, the VOC content limit for the coating, and that only coatings meeting the applicable VOC content limit are to be employed, unless otherwise controlled pursuant to paragraph (D)(2) of this rule or exempted pursuant to paragraph (D)(3) of this rule.
- (b) For the handling and transfer of marine coatings and thinners, the owner or operator shall provide an implementation plan that addresses the procedures for ensuring compliance with the requirements under paragraph (E) of this rule.
- (c) For any coating operation that is equipped with a VOC emission control system to comply with paragraph (D)(2) of this rule, the owner or operator shall submit in the initial compliance status report:
 - (i) Information on the types of coatings to be controlled.
 - (ii) Identification and description of each monitoring device employed to comply with paragraph (G) of this rule.
 - (iii) The results of compliance tests conducted pursuant to paragraph (I) of this rule to determine the overall control efficiency of the VOC emission control system and the control efficiency of any thermal or catalytic oxidizer within the VOC emission control system.
 - (iv) A complete test report for any compliance tests of the VOC emission control system.

A complete test report shall include a brief process description, sampling site description, description of sampling and analysis procedures and any modifications to standard procedures, quality assurance procedures, record of operating conditions during the test, record of preparation of standards, record of calibrations, raw data sheets for field sampling, raw data sheets for field and laboratory analyses, documentation of calculations, and any other information required by the test method.
 - (v) For any compliance tests of the VOC emission control system, the compliance test monitoring data recorded pursuant to paragraph (I) (2) of this rule, including the operating parameter values established for any monitoring device.

(3) Semiannual compliance status reports.

The owner or operator of shipbuilding or ship repair operations subject to this rule shall submit semiannual compliance status reports no later than thirty calendar days after the end of each six month period to the appropriate Ohio EPA district office or local air agency. The first report shall be submitted no later than thirty calendar days after the end of the first six month period following the compliance date. Subsequent reports shall be submitted no later than thirty calendar days after the end of each six month period following the first report or no later than thirty calendar days after the end of each six month period otherwise established within a permit issued for the shipbuilding or ship repair operations. For each semiannual compliance status report, the owner or operator shall submit the following information for the six month period covered by the report:

- (a) For any coating operation subject to paragraph (D)(1) of this rule, the owner or operator shall state in the semiannual compliance status report any changes to the previous reporting of the types of coatings and the VOC content limits for the coatings.
- (b) For the handling and transfer of marine coatings and thinners, the owner or operator shall provide any change to the implementation plan identified in paragraph (K)(2)(b) of this rule that addresses the procedures for ensuring compliance with the requirements under paragraph (E) of this rule.
- (c) For any VOC emission control system employed to meet paragraph (D)(2) of this rule, any changes to monitoring devices previously reported and required under paragraph (G) of this rule.
- (d) If any subsequent compliance tests of the VOC emission control system are conducted during the semiannual reporting period after the initial compliance status report has been submitted, the semiannual compliance status report shall include the results of each compliance test, a complete test report, and the compliance test monitoring data as described under paragraphs (K)(2)(c)(iii) to (K)(2)(c)(v) of this rule.
- (e) The owner or operator shall submit with the semiannual compliance status report, the following compliance certifications, where applicable:
 - (i) For any coating that is subject to a VOC content limit of paragraph (D)(1) of this rule, the compliance certification shall state that only coatings that comply with the applicable VOC content limit have been used each operating day in the semiannual reporting period, or should otherwise identify the periods of use of coatings that did not comply, the reasons for such use of noncompliant coatings, and

the amounts and VOC contents of each such noncompliant coating used. Use of a noncompliant coating is a separate violation for each day the noncompliant coating is used.

- (ii) For the handling and transfer of marine coatings and thinners, the owner or operator provide any changes to the implementation plan that addresses the procedures for ensuring compliance with the requirements under paragraph (E) of this rule and shall submit information on any deviations from the implementation plan or paragraph (E) of this rule.
- (iii) For any coating operation that is equipped with a VOC emission control system to comply with paragraph (D)(2) of this rule:
 - (a) The compliance certification shall state that the three-hour three hour block averages of the monitoring parameters recorded pursuant to paragraph (K)(5) of rule 3745-21-15 of the Administrative Code had complied with the operating limits (operating parameter values) for the monitoring parameters established under paragraph (J)(2) of this rule during of all periods of operation of the coating operation in the semiannual reporting period; or should otherwise identify the times and durations of all periods of noncompliance and the reasons for noncompliance.
 - (b) The compliance certification shall identify the times and durations of all periods during coating operation or control operation when the monitoring device is not working, as recorded pursuant to paragraph (J)(6) of this rule and paragraph (K)(5) of rule 3745-21-15 of the Administrative Code.
 - (c) For any capture system bypass line, the compliance certification shall identify the times and durations of all periods in which the captured VOC emissions were discharged to atmosphere instead of a control device, as recorded pursuant to paragraph (J)(6) of this rule and paragraph (K)(5)(f) of rule 3745-21-15 of the Administrative Code, and the reasons for the discharges to atmosphere.
- (iv) The compliance certification shall state that the overall reduction and control of VOC emissions, based on the most recent compliance test conducted in accordance with paragraph (I) of this rule, has

met paragraph (D)(2) of this rule for each coating designated for control during the semiannual reporting period, or should otherwise identify the periods of noncompliance and the reasons for noncompliance.

- (v) For coatings subject to the low usage exemption under paragraph (D)(3)(c) of this rule, the compliance certification shall state that the usage of these coatings during the semiannual reporting period did not exceed the usage restrictions, or should otherwise identify for each noncompliance of any usage restriction the reasons for the noncompliant usage and the amounts and VOC contents of the coatings used in the noncompliant usage.
- (vi) The compliance certification shall identify and describe any corrective actions considered and implemented for any noncompliance being reported in the compliance certification.
- (vii) The compliance certification shall be signed by the responsible official of a Title V facility, as defined in rule 3745-77-01 of the Administrative Code or the signatory authority under rule 3745-31-02 of the Administrative Code for a facility that is not Title V, that owns or operates the shipbuilding or ship repair operations.

(L) Applicability notification and permit application.

- (1) The owner or operator of a shipbuilding or ship repair operation that is subject to this rule, is located in located in Ashtabula, Cuyahoga, Geauga, Lake, Lorain, Medina, Portage, or Summit county, and has an initial startup of shipbuilding or ship repair operations before August 25, 2008 shall notify the appropriate Ohio EPA district office or local air agency in writing that the facility is subject to this rule not later than October 24, 2008, providing the information specified in paragraph (L)(5) of this rule.
- (2) The owner or operator of a shipbuilding or ship repair operation that is subject to this rule, is located in Ashtabula, Cuyahoga, Geauga, Lake, Lorain, Medina, Portage, or Summit county, and has an initial startup of shipbuilding or ship repair operations on or after August 25, 2008 shall notify the appropriate Ohio EPA district office or local air agency in writing that the facility is subject to this rule not later than either the date of initial startup of the facility's coating operations or October 24, 2008 (whichever is later), providing the information specified in paragraph (L)(5) of this rule. The application for a permit-to-install under rule 3745-31-02 of the Administrative Code may be used to fulfill the notification requirements of this paragraph.

- (3) The owner or operator of a shipbuilding or ship repair operation that is subject to this rule, is located in Butler, Clermont, Hamilton or Warren county, and has an initial startup of shipbuilding or ship repair operations before the effective date of this rule shall notify the appropriate Ohio EPA district office or local air agency in writing that the facility is subject to this rule not later than sixty days after the effective date of this rule, providing the information specified in paragraph (L)(5) of this rule.
- (4) The owner or operator of a shipbuilding or ship repair operation that is subject to this rule, is located in Butler, Clermont, Hamilton or Warren county, and has an initial startup of shipbuilding or ship repair operations on or after the effective date of this rule shall notify the appropriate Ohio EPA district office or local air agency in writing that the facility is subject to this rule not later than either the date of initial startup of the facility's coating operations or sixty days after the effective date of this rule (whichever is later), providing the information specified in paragraph (L)(5) of this rule. The application for a permit-to-install under rule 3745-31-02 of the Administrative Code may be used to fulfill the notification requirements of this paragraph.
- ~~(1)(5) The owner or operator of shipbuilding or ship repair operations that are subject to this rule and that have an initial startup of shipbuilding or ship repair operations before August 25, 2008 shall notify the appropriate Ohio EPA district office or local air agency in writing that the facility is subject to this rule. The notification, which shall be submitted not later than October 24, 2008, required in paragraphs (L)(1) to (L)(4) of this rule shall provide the following information:~~
- ~~(a) Name and address of the owner or operator.~~
 - ~~(b) Address (i.e., physical location) of the facility.~~
 - ~~(c) Equipment description and Ohio EPA application number (if assigned) of any coating operations.~~
 - ~~(d) Identification of the applicable requirements, the means of compliance, and the compliance date for the coating operations under this rule.~~
 - ~~(e) An application for an operating permit or an application for a modification to an operating permit in accordance with Chapter 3745-77 of the Administrative Code (for sources subject to the Title V permit program) or an application for a permit-to-install and operate or an application for a modification to a permit-to-install and operate in accordance with Chapter 3745-31 of the Administrative Code (for sources not subject to~~

the Title V permit program) for each subject process that meets one of the following:

- (i) The process does not possess an effective operating permit or permit-to-install and operate.
- (ii) The process possesses an effective operating permit or permit-to-install and operate and the owner or operator cannot certify in writing to the director that such subject process is in compliance with this rule. An application for an operating permit or permit-to-install and operate is not required provided the subject process is operating under an effective permit and certifies compliance. Such certification shall include all compliance certification requirements under paragraph (K)(2) of this rule.

~~(2) The owner or operator of shipbuilding or ship repair operations that are subject to this rule and that have an initial startup of shipbuilding or ship repair operations on or after August 25, 2008 shall notify the appropriate Ohio EPA district office or local air agency in writing that the facility is subject to this rule. The notification, which shall be submitted not later than either the date of initial startup of the facility's coating operations or October 24, 2008 (whichever is later), shall provide the information listed under paragraph (L)(1) of this rule. The application for a permit to install under rule 3745-31-02 of the Administrative Code may be used to fulfill the notification requirements of this paragraph.~~

Effective: 3/27/2022
Five Year Review (FYR) Dates: 11/29/2021 and 11/29/2026

CERTIFIED ELECTRONICALLY

Certification

03/17/2022

Date

Promulgated Under: 119.03
Statutory Authority: 3704.03(E)
Rule Amplifies: 3704.03(A), 3704.03(E)
Prior Effective Dates: 08/25/2008, 10/15/2015

3745-21-21

Storage of volatile organic liquids in fixed roof tanks and external floating roof tanks.

[Comment: For dates and availability of non-regulatory government publications, publications of recognized organizations and associations, federal rules, and federal statutory provisions referenced in this rule, see paragraph (JJ) of rule 3745-21-01 of the Administrative Code titled "referenced materials."]

(A) Applicability.

This rule shall apply to any storage tank that stores volatile organic liquids and meets all of the following criteria: either paragraphs (A)(1) and (A)(2) of this rule or paragraphs (A)(3) and (A)(4) of this rule:

~~(1) Tanks that store volatile organic liquids.~~

~~(2)~~(1) The tank is located in Ashtabula, Cuyahoga, Geauga, Lake, Lorain, Medina, Portage, or Summit county.

~~(3)~~(2) The facility has a combined total potential to emit for VOC emissions equal to or greater than one hundred tons of VOCs per calendar year on or after May 27, 2005, from all of the following:

(a) All volatile organic liquid storage tanks.

(b) All non-CTG sources.

(c) Unregulated emissions from CTG sources.

(3) The tank is located in Butler, Clermont, Hamilton or Warren county.

(4) The facility has a combined total potential to emit for VOC emissions equal to or greater than one hundred tons of VOCs per calendar year on or after the effective date of this rule from all of the following:

(a) All volatile organic liquid storage tanks.

(b) All non-CTG sources.

(c) Unregulated emissions from CTG sources.

(B) The definitions applicable to this rule are contained in paragraphs (B) and (E) of rule 3745-21-01 of the Administrative Code.

(C) Storage of volatile organic liquids in fixed roof tanks.

- (1) Except where exempted under paragraph (C)(5) of this rule, no owner or operator of a fixed roof tank shall place, store, or hold any volatile organic liquid with a maximum true vapor pressure which is greater than 0.75 pounds per square inch absolute, but less than 11.1 pounds per square inch absolute, in any such tank, after the date specified in paragraph (G) of this rule, unless such tank is designed or equipped with one of the following vapor control systems:
 - (a) An internal floating roof that meets paragraph (C)(3) of this rule.
 - (b) A closed vent system and control device that meets paragraph (C)(4) of this rule.
- (2) Except where exempted under paragraph (C)(5) of this rule, no owner or operator of a fixed roof tank shall place, store, or hold any volatile organic liquid with a maximum true vapor pressure which is equal to or greater than 11.1 pounds per square inch absolute, in any such tank, after the date specified in paragraph (G) of this rule, unless such tank is designed or equipped with a closed vent system and control device that meets paragraph (C)(4) of this rule.
- (3) If the fixed roof tank is equipped with an internal floating roof, the following shall be met:
 - (a) The internal floating roof shall rest or float on the liquid surface (but not necessarily in complete contact with it) inside a storage vessel that has a fixed roof. The internal floating roof shall float on the liquid surface at all times, except during initial fill and during those intervals when the storage vessel is completely emptied or subsequently emptied and refilled. When the roof is resting on the leg supports, the process of filling, emptying, or refilling shall be continuous and shall be accomplished as rapidly as possible.
 - (b) Each internal floating roof shall be equipped with one of the following closure devices between the wall of the storage vessel and the edge of the internal floating roof:
 - (i) A foam or liquid-filled seal mounted in contact with the liquid (liquid-mounted seal). A liquid-mounted seal means a foam or liquid-filled seal mounted in contact with the liquid, between the wall of the storage vessel and the floating roof, and extending continuously around the circumference of the tank.
 - (ii) Two seals mounted one above the other, so that each forms a continuous closure that completely covers the space between the

wall of the storage vessel and the edge of the internal floating roof. The lower seal may be vapor-mounted, but both shall be continuous.

- (iii) A mechanical shoe seal. A mechanical shoe seal is a metal sheet held vertically against the wall of the storage vessel by springs or weighted levers and is connected by braces to the floating roof. A flexible coated fabric (envelope) spans the annular space between the metal sheet and the floating roof.
- (c) Automatic bleeder vents shall be equipped with a gasket and are to be closed at all times when the roof is floating except when the roof is being floated off or is being landed on the roof leg supports. Rim space vents shall be equipped with a gasket and are to be set to open only when the internal floating roof is not floating or at the manufacturer's recommended setting.
- (d) Each opening in a non-contact internal floating roof, except for automatic bleeder vents (vacuum breaker vents) and the rim space vents, shall provide a projection below the liquid surface.
- (e) Each opening in the internal floating roof, except for leg sleeves, automatic bleeder vents, rim space vents, column wells, ladder wells, sample wells, and stub drains, shall be equipped with a cover or lid which shall be maintained in a closed position at all times (i.e., no visible gap) except when the device is in actual use. The cover or lid shall be equipped with a gasket. Covers on each access hatch and automatic gauge float well shall be bolted except when they are in use.
- (f) The sample well, which penetrates the internal floating roof for the purpose of sampling, shall have a slit fabric cover that covers at least ninety per cent of the opening.
- (g) Each penetration of the internal floating roof that allows for passage of a ladder shall have a gasketed sliding cover.
- (h) Inspection.

The owner or operator of each storage vessel equipped with an internal floating roof, shall comply with the following:

- (i) Visually inspect the internal floating roof, the primary seal, and the secondary seal (if one is in service), prior to filling the storage vessel with a volatile organic liquid. If there are holes, tears, or other openings in the primary seal, the secondary seal, or the seal

fabric, or defects in the internal floating roof, or both, the owner or operator shall repair the items before filling the storage vessel.

- (ii) For vessels equipped with a liquid-mounted or mechanical shoe primary seal, visually inspect the internal floating roof and the primary seal or the secondary seal (if one is in service) through manholes and roof hatches on the fixed roof at least once every twelve months after initial fill. If the internal floating roof is not resting on the surface of the volatile organic liquid inside the storage vessel, or there is liquid accumulated on the roof, or the seal is detached, or there are holes or tears in the seal fabric, the owner or operator shall repair the items or empty and remove the storage vessel from service within forty-five days. If a failure that is detected during inspections required in this paragraph cannot be repaired within forty-five days and if the vessel cannot be emptied within forty-five days, a thirty-day extension may be requested from the director in the inspection report required in paragraph (C)(3)(j)(iii) of this rule. Such a request for an extension shall document that alternate storage capacity is unavailable and specify a schedule of actions the company will take that will ensure that the control equipment will be repaired or the vessel will be emptied within thirty days.
- (iii) For vessels equipped with both primary and secondary seals, visually inspect the vessel as follows:
 - (a) As specified in paragraph (C)(3)(h)(iv) of this rule at least every five years.
 - (b) At least once every twelve months as specified in paragraph (C)(3)(h)(ii) of this rule.
- (iv) Visually inspect the internal floating roof, the primary seal, the secondary seal (if one is in service), gaskets, slotted membranes and sleeve seals (if any) each time the storage vessel is emptied and degassed. If the internal floating roof has defects, the primary seal has holes, tears, or other openings in the seal or the seal fabric, or the secondary seal has holes, tears, or other openings in the seal or the seal fabric, or the gaskets no longer close off the liquid surfaces from the atmosphere, or the slotted membrane has more than ten per cent open area, the owner or operator shall repair the items as necessary so that none of the conditions specified in this paragraph exist before refilling the storage vessel with a

volatile organic liquid. In no event shall inspections conducted in accordance with this provision occur at intervals greater than ten years in the case of vessels conducting the annual visual inspection as specified in paragraphs (C)(3)(h)(ii) and (C)(3)(h)(iii)(b) of this rule and at intervals no greater than five years in the case of vessels specified in paragraph (C)(3)(h)(iii)(a) of this rule.

- (i) Notify the director in writing at least thirty days prior to the filling or refilling of each storage vessel for which an inspection is required by paragraphs (C)(3)(h)(i) and (C)(3)(h)(iv) of this rule to afford the director or the director's authorized designee the opportunity to have an observer present. If the inspection required by paragraph (C)(3)(h)(iv) of this rule is not planned and the owner or operator could not have known about the inspection thirty days in advance of refilling the tank, the owner or operator shall notify the director at least seven days prior to the refilling of the storage vessel. Notification shall be made by telephone immediately followed by written documentation demonstrating why the inspection was unplanned. Alternatively, this notification including the written documentation may be made in writing and sent by express mail so that it is received by the director at least seven days prior to the refilling.
- (j) Recordkeeping and reporting.

The owner or operator of each storage vessel equipped with an internal floating roof shall keep records and furnish reports in accordance with the following:

- (i) Furnish the director with a report that describes the control equipment and certifies that the control equipment meets the specifications of paragraph (C) of this rule. This report shall be submitted in accordance with the requirements specified in paragraph (H) of this rule.
- (ii) Keep a record of each inspection performed as required by paragraphs (C)(3)(h)(i) to (C)(3)(h)(iv) of this rule. Each record shall identify the storage vessel for which the inspection was performed and shall contain the date the vessel was inspected and the observed condition of each component of the control equipment (seals, internal floating roof, and fittings).
- (iii) If any of the conditions described in paragraph (C)(3)(h)(ii) of this rule are detected during the annual visual inspection required by paragraph (C)(3)(h)(ii) of this rule, a report shall be furnished to

the director within thirty days of the inspection. Each report shall identify the storage vessel, the nature of the defects, and the date the storage vessel was emptied or the nature of and date the repair was made.

- (k) After each inspection required by paragraph (C)(3)(h)(iii) of this rule that finds holes or tears in the seal or seal fabric, or defects in the internal floating roof, or other control equipment defects listed in paragraph (C)(3)(h)(ii) or (C)(3)(h)(iv) of this rule, a report shall be furnished to the director within thirty days of the inspection. The report shall identify the storage vessel and the reason it did not meet the specifications of paragraph (C)(3) of this rule and list each repair made.
 - (l) The owner or operator shall keep copies of all reports and records required by paragraph (C)(3)(j) of this rule for at least five years.
- (4) If the fixed roof tank is equipped with a closed vent system and control device, as required by paragraph (C)(1)(b) or (C)(2) of this rule, the following specifications shall be met:
- (a) The closed vent system shall be designed to collect all VOC vapors and gases discharged from the storage vessel and operated with no detectable emissions, as indicated by an instrument reading of less than five hundred parts per million above background and visual inspections, as determined by the methods specified in 40 CFR 60.485(c).
 - (b) If a control device other than a flare is employed, the control device shall be designed and operated to reduce inlet VOC emissions by ninety five per cent or greater. The control efficiency shall be determined in accordance with paragraph (C) of rule 3745-21-10 of the Administrative Code.
 - (c) If a flare is used as the control device, it shall meet the specifications described in the general control device requirements specified in 40 CFR 60.18.
 - (d) The owner or operator of each tank that is equipped with a closed vent system and control device other than a flare, to meet the control requirements as required in paragraph (C)(4) of this rule, shall meet the specifications identified in paragraphs (C)(4)(a) and (C)(4)(b) of this rule and shall submit, for approval by the director, an operating plan containing the following information:

- (i) Documentation demonstrating that the control device will achieve the required control efficiency during maximum loading conditions. This documentation is to include a description of the gas stream which enters the control device, including flow and VOC content under varying liquid level conditions (dynamic and static) and manufacturer's design specifications for the control device. If the control device or the closed vent capture system receives vapors, gases, or liquids other than fuels from sources that are not designated sources under this rule, the efficiency demonstration is to include consideration of all vapors, gases, and liquids received by the closed vent capture system and control device. If an enclosed combustion device with a minimum residence time of 0.75 seconds and a minimum temperature of eight hundred sixteen degrees centigrade is used to meet the ninety-five per cent control requirement, documentation that those conditions will exist during all loading conditions is sufficient to meet the requirements of this paragraph.
 - (ii) A description of the parameter or parameters to be monitored to ensure that the control device will be operated in conformance with its design and an explanation of the criteria used for selection of that parameter (or parameters).
- (e) Operate the closed vent system and control device and monitor the parameters of the closed vent system and control device in accordance with the operating plan submitted to the director in accordance with paragraph (C)(4)(d) of this rule, unless the plan was modified by the director during the review process, in which case, the modified plan applies. The operating plan required by paragraph (C)(4)(d) of this rule shall be maintained by the owner or operator for the life of the control equipment and shall be made available to the director upon request.
- (f) Any approval granted by the director in accordance with paragraph (C)(4)(d) of this rule shall be approved by the USEPA as a revision of the Ohio state implementation plan.
- (g) The owner or operator of each source that is equipped with a closed vent system and a flare, to meet the control requirements in paragraphs (C)(4)(a) and (C)(4)(c) of this rule, shall meet the requirements as specified in the general control device requirements of 40 CFR 60.18(e) and (f).
- (h) Monitoring, recordkeeping and reporting.

- (i) After installing control equipment in accordance with paragraph (C)(1)(b) or (C)(2) of this rule (closed vent system and control device other than a flare), the owner or operator shall keep the following records:
 - (a) A copy of the operating plan.
 - (b) A record of the measured values of the parameters monitored in accordance with paragraph (C)(4)(e) of this rule.
 - (ii) After installing a closed vent system and flare to comply with the control requirements of paragraph (C)(1)(b) or (C)(2) of this rule, the owner or operator shall meet the following:
 - (a) A report containing the measurements required by 40 CFR 60.18(f)(1) to (f)(6), shall be furnished to the director as required by 40 CFR 60.8. This report shall be submitted within six months of the initial start-up date of the flare.
 - (b) Records shall be kept of all periods of operation during which the flare pilot flame is absent.
 - (c) Semiannual reports of all periods of time recorded under paragraph (C)(4)(h)(ii)(b) of this rule during which the pilot flame was absent shall be furnished to the director. These reports shall be submitted to the appropriate Ohio EPA district office or local air agency by July fifteenth and January fifteenth of each calendar year and shall cover the previous six-month period.
 - (i) The owner or operator shall keep copies of all reports and records required by paragraph (C)(4)(h) of this rule for at least five years.
 - (5) A fixed roof tank with a capacity less than forty thousand gallons is exempt from paragraphs (C)(1) and (C)(2) of this rule.
- (D) Storage of volatile organic liquids in external floating roof tanks.
- (1) Except where exempted under paragraph (D)(2) of this rule, no owner or operator of an external floating roof tank shall place, store, or hold any volatile organic liquid in any such tank, after the date specified in paragraph (F) of this rule, unless the following is met:

- (a) Each external floating roof is equipped with a closure device between the wall of the storage vessel and the roof edge. The closure device is to consist of two seals, one above the other. The lower seal is referred to as the primary seal, and the upper seal is referred to as the secondary seal.
 - (i) Except as provided in paragraph (D)(3)(c) of this rule, the primary seal shall completely cover the annular space between the edge of the floating roof and tank wall and shall be either a liquid mounted seal or a shoe seal.
 - (ii) The secondary seal shall completely cover the annular space between the external floating roof and the wall of the storage vessel in a continuous fashion, except as allowed in paragraph (D)(3)(c) of this rule.
 - (iii) The tank shall be equipped with the closure device that meets the requirements of this rule after the next scheduled tank cleaning, but no later than the date specified in paragraph (G) of this rule.
 - (b) Except for automatic bleeder vents and rim space vents, each opening in a non-contact external floating roof shall provide a projection below the liquid surface. Except for automatic bleeder vents, rim space vents, roof drains, and leg sleeves, each opening in the roof is to be equipped with a gasketed cover, seal, or lid that is to be maintained in a closed position at all times (i.e., no visible gap) except when the device is in actual use. Automatic bleeder vents are to be closed at all times when the roof is floating except when the roof is being floated off or is being landed on the roof leg supports. Rim vents are to be set to open when the roof is being floated off the roof leg supports or at the manufacturer's recommended setting. Automatic bleeder vents and rim space vents are to be gasketed. Each emergency roof drain is to be provided with a slotted membrane fabric cover that covers at least ninety percent of the area of the opening.
 - (c) The roof shall be floating on the liquid at all times (i.e., off the roof leg supports) except when the tank is completely emptied and subsequently refilled. The process of filling, emptying, or refilling when the roof is resting on the leg supports shall be continuous and shall be accomplished as rapidly as possible.
- (2) The following external floating roof tanks shall be exempted from paragraph (D) (1) of this rule:
- (a) Any tank that has a capacity of less than forty thousand gallons.

- (b) Any tank that contains a volatile organic liquid which, as stored, has a maximum true vapor pressure less than 0.75 pounds per square inch absolute.

(3) Inspection and measurement.

The owner or operator of an external floating roof tank shall do the following:

- (a) Determine the gap areas and maximum gap widths between the primary seal and the wall of the storage vessel and between the second seal and the wall of the storage vessel according to the following frequency:
 - (i) Measurements of gaps between the tank wall and the primary seal (seal gaps) shall be performed during the hydrostatic testing of the vessel or within sixty days of the initial fill with a volatile organic liquid and at least every five years thereafter.
 - (ii) Measurements of gaps between the tank wall and the secondary seal shall be performed within sixty days of the initial fill with a volatile organic liquid and at least once per year thereafter.
 - (iii) If any source ceases to store a volatile organic liquid for a period of one year or more, subsequent introduction of a volatile organic liquid into the vessel shall be considered an initial fill for the purposes of paragraphs (D)(3)(a)(i) and (D)(3)(a)(ii) of this rule.
- (b) Determine gap widths and areas in the primary and secondary seals individually according to the following procedures:
 - (i) Measure the seal gaps, if any, at one or more floating roof levels when the roof is floating off the roof leg supports.
 - (ii) Measure the seal gaps around the entire circumference of the tank, in each place where a one-eighth inch diameter uniform probe passes freely (without forcing or binding against the seal) between the seal and the wall of the storage vessel, and measure the circumferential distance of each such location.
 - (iii) The total surface area of each gap described in paragraph (D)(b)(ii) of this rule shall be determined by using probes of various widths to measure accurately the actual distance from the tank wall to the seal and then multiplying each such width by its respective circumferential distance.

- (iv) Add the gap surface area of each gap location for the primary seal and the secondary seal individually and divide the sum for each by the nominal diameter of the tank and compare each ratio to the respective standards in paragraph (D)(3)(c)(i) or (D)(3)(c)(ii) of this rule.
- (c) Make necessary repairs or empty the storage vessel within forty-five days of identification in any inspection for seals not meeting the following:
- (i) The accumulated area of gaps between the tank wall and the mechanical shoe or liquid-mounted primary seal shall not exceed 10.0 square inches per foot of tank diameter, and the width of any portion of any gap shall not exceed 1.5 inches. There are to be no holes, tears, or other openings in the shoe, seal fabric, or seal envelope.
 - (ii) The secondary seal is to meet the following:
 - (a) The secondary seal is to be installed above the primary seal so that the seal completely covers the space between the roof edge and the tank wall except as provided in paragraph (D)(3)(c)(ii)(b) of this rule.
 - (b) The accumulated area of gaps between the tank wall and the secondary seal used in combination with a metallic shoe or liquid-mounted primary seal shall not exceed 1.0 square inches per foot of tank diameter, and the width of any portion of any gap shall not exceed 0.5 inches. There shall be no gaps between the tank wall and the secondary seal when used in combination with a vapor mounted primary seal.
 - (c) There are to be no holes, tears, or other openings in the seal or seal fabric.

If a failure that is detected during inspections required in paragraph (D)(3)(a) of this rule cannot be repaired within forty-five days and if the vessel cannot be emptied within forty-five days, a thirty-day extension may be requested from the director in the inspection report required in paragraph (D)(4)(d) of this rule. Such extension request shall include a demonstration of unavailability of alternative storage capacity and a specification of a schedule that will assure that the control equipment will be repaired or the vessel will be emptied as soon as possible.

- (d) Notify the director thirty days in advance of any gap measurements required by paragraph (D)(3)(a) of this rule to afford the director the opportunity to have an observer present.
- (e) Visually inspect the external floating roof, the primary seal, secondary seal, and fittings each time the vessel is emptied and degassed.
 - (i) If the external floating roof has defects, the primary seal has holes, tears, or other openings in the seal or the seal fabric, or the secondary seal has holes, tears, or other openings in the seal or the seal fabric, the owner or operator shall repair the items as necessary so that none of the conditions specified in this paragraph exist before filling or refilling the storage vessel with a volatile organic liquid.
 - (ii) For all the inspections required by paragraph (D)(3)(e) of this rule, the owner or operator shall notify the director in writing at least thirty days prior to the filling or refilling of each storage vessel to afford the director or the director's authorized designee the opportunity to inspect the storage vessel prior to refilling. If the inspection required by paragraph (D)(3)(e) of this rule is not planned and the owner or operator could not have known about the inspection thirty days in advance of refilling the tank, the owner or operator shall notify the director at least seven days prior to the refilling of the storage vessel. Notification shall be made by telephone immediately followed by written documentation demonstrating why the inspection was unplanned. Alternatively, this notification including the written documentation may be made in writing and sent by express mail so that it is received by the director at least seven days prior to the refilling.

(4) Recordkeeping and reporting.

The owner or operator of an external floating roof tank shall meet the following:

- (a) Furnish the director with a report that describes the control equipment and certifies that the control equipment meets paragraphs (D)(1) and (D)(3) of this rule. This report shall be submitted in accordance with paragraph (H) of this rule.
- (b) Keep a record of each gap measurement performed as required by paragraphs (D)(3)(a) and (D)(3)(b) of this rule. Each record shall identify

the storage vessel in which the measurement was performed and shall contain the following:

- (i) The date of measurement.
- (ii) The raw data obtained in the measurement.
- (iii) The calculations described in paragraph (D)(3)(b) of this rule.

(c) Within sixty days of performing the seal gap measurements required by paragraph (D)(3)(a) of this rule, furnish the director with a report that contains the following:

- (i) The date of measurement.
- (ii) The raw data obtained in the measurement.
- (iii) The calculations described in paragraph (D)(3)(b) of this rule.

(d) After each seal gap measurement that detects gaps exceeding the limitations specified by paragraph (D)(3)(c) of this rule, submit a report to the director within thirty days of the inspection. The report shall identify the vessel and contain the information specified in paragraph (D)(4)(c) of this rule, the date the vessel was emptied or the repairs made, and the date of the repairs.

(E) Recordkeeping for fixed roof tanks and external floating roof tanks storing volatile organic liquids.

(1) Any owner or operator of a fixed roof or an external floating roof tank that is not exempted pursuant to paragraph (C)(5) or (D)(2) of this rule shall maintain records of the following information in a readily accessible location for at least five years and shall make copies of the records available to the director upon verbal or written request:

- (a) The types of volatile organic liquids stored in the tank.
- (b) The maximum true vapor pressure (pounds per square inch absolute), as stored, of each liquid that has a maximum true vapor pressure greater than 0.5 pounds per square inch absolute.
- (c) The dimension and volume of each tank.

(2) The owner or operator of each storage vessel that is exempt pursuant to paragraph (C)(5) or (D)(2) of this rule shall maintain records of the following information in a readily accessible location for at least five years and shall make copies of the records available to the director upon verbal or written request:

(a) The dimension of the storage vessel.

(b) An analysis of the capacity of the storage vessel.

Each storage vessel with a design capacity less than forty thousand gallons is not subject to any provisions of this rule other than those required by maintaining readily accessible records of the dimensions of the storage vessel and analysis of the capacity of the storage vessel.

(3) If an owner or operator places, stores, or holds in a fixed roof tank or an external floating roof tank, that is not exempted pursuant to paragraph (C)(5) or (D)(2) of this rule, any volatile organic liquid with a true vapor pressure which is greater than 0.75 pounds per square inch absolute and such tank does not comply with paragraph (C)(1), (C)(2), or (D)(1) of this rule, the owner or operator shall so notify the director within thirty days of becoming aware of the occurrence.

(4) The owner or operator shall keep copies of all reports and records required by paragraphs (C)(3)(j), (C)(4)(h), (D)(4), and (I) of this rule for at least five years.

(F) Monitoring of volatile organic liquid operations.

(1) Except as provided in paragraph (F)(4) of this rule, the owner or operator of each storage vessel with a design capacity greater than or equal to forty thousand gallons storing a liquid with a maximum true vapor pressure that is normally less than 0.75 pounds per square inch absolute shall notify the director within thirty days when the maximum true vapor pressure of the liquid exceeds 0.75 pounds per square inch absolute.

(2) Available data on the storage temperature may be used to determine the maximum true vapor pressure.

(a) For liquids in vessels operated above or below ambient temperatures, the maximum true vapor pressure is calculated based upon the highest expected calendar-month average of the storage temperature. For vessels operated at ambient temperatures, the maximum true vapor pressure is calculated based upon the maximum local monthly average ambient temperature as reported by the national weather service.

- (b) For other liquids, the vapor pressure shall be determined using one of the following:
 - (i) ASTM method D2879-10.
 - (ii) As measured by an appropriate method approved by the director and USEPA.
 - (iii) As calculated by an appropriate method approved by the director and USEPA.
- (3) The owner or operator of each vessel storing a mixture of indeterminate or variable composition shall be subject to the following:
 - (a) Prior to the initial filling of the vessel, the maximum true vapor pressure for the range of anticipated liquid compositions to be stored will be determined using the methods described in paragraph (F)(2) of this rule.
 - (b) For vessels in which the vapor pressure of the anticipated liquid composition is 0.5 pounds per square inch absolute or greater but less than 0.75 pounds per square inch absolute, an initial physical test of the vapor pressure is required; a physical test at least once every six months thereafter is required as determined by the following methods:
 - (i) ASTM method D2879-10.
 - (ii) ASTM method D323-08.
 - (iii) As measured by an appropriate method approved by the director.
- (4) The owner or operator of each vessel equipped with a closed vent system and control device that meets paragraph (C)(4) of this rule is exempt from paragraphs (F)(1) and (F)(2) of this rule.

(G) Compliance dates.

The owner or operator of a facility that is subject to this rule shall comply with this rule no later than the following dates:

- (1) For any storage of a volatile organic liquid located in Ashtabula, Cuyahoga, Geauga, Lake, Lorain, Medina, Portage, or Summit county which commenced operation after August 25, 2008, the compliance date for the operation is the initial startup date of the operation or August 25, 2009, whichever is later.

- (2) For any storage of a volatile organic liquid located in Ashtabula, Cuyahoga, Geauga, Lake, Lorain, Medina, Portage, or Summit county which commenced operation before August 25, 2008, the compliance date for the operation is August 25, 2009.
- (3) For any storage of a volatile organic liquid located in Butler, Clermont, Hamilton, or Warren county which commenced operation on or after the effective date of this rule, the compliance date for the operation is the initial startup date of the operation.
- (4) For any storage of a volatile organic liquid located in Butler, Clermont, Hamilton, or Warren county which commenced operation before the effective date of this rule, the compliance date for the operation is either March 1, 2023 or the initial startup date of the operation, whichever is later.

(H) Compliance certification.

- (1) The owner or operator of a facility that is subject to this rule shall notify the appropriate Ohio EPA district office or local air agency in writing within thirty days following the completion of any of the following requirements. For a volatile organic liquid storage operation subject to the volatile organic emission control requirements in paragraph (C)(1), (C)(2) or (D)(1) of this rule:
 - (a) The completion of installation and initial use of vapor control equipment employed for all tanks that store a volatile organic liquid.
 - (b) The completion of any inspection or measurement requirements specified under paragraphs (C)(3)(h) and (D)(3) of this rule for all tanks that store a volatile organic liquid.
- (2) The compliance certification under paragraph (H)(1) of this rule shall provide the following, where applicable:
 - (a) A description of the requirements.
 - (b) A description of the vapor control equipment employed.
 - (c) A description of the monitoring devices.
 - (d) A description of the records that document continuing compliance.
 - (e) The results of any compliance tests, including documentation of test data.

- (f) The results of any records that document continuing compliance, including calculations.
- (g) A statement by the owner or operator of the affected facility as to whether the volatile organic liquid storage operation has complied with the requirements.

(I) Applicability notification, compliance certification, and permit application.

- (1) The owner or operator of a facility that is subject to this rule, is located in located in Ashtabula, Cuyahoga, Geauga, Lake, Lorain, Medina, Portage, or Summit county, and has an initial startup of a storage tank for volatile organic liquids before August 25, 2008 shall notify the appropriate Ohio EPA district office or local air agency in writing that the volatile organic liquid storage tank is subject to this rule not later than October 24, 2008 (or within sixty days after the volatile organic liquid storage tank becomes subject to this rule), providing the information specified in paragraph (I)(5) of this rule.
- (2) The owner or operator of a facility that is subject to this rule, is located in Ashtabula, Cuyahoga, Geauga, Lake, Lorain, Medina, Portage, or Summit county, and has an initial startup of a storage tank for volatile organic liquids on or after August 25, 2008 shall notify the appropriate Ohio EPA district office or local air agency in writing that the volatile organic liquid storage tank is subject to this rule not later than either the date of initial startup of the the subject coating operation or October 24, 2008 (whichever is later), providing the information specified in paragraph (I)(5) of this rule. The application for a permit-to-install under rule 3745-31-02 of the Administrative Code may be used to fulfill the notification requirements of this paragraph.
- (3) The owner or operator of a facility that is subject to this rule, is located in Butler, Clermont, Hamilton or Warren county, and has an initial startup of a storage tank for volatile organic liquids before the effective date of this rule shall notify the appropriate Ohio EPA district office or local air agency in writing that the volatile organic liquid storage tank is subject to this rule not later than sixty days after the effective date of this rule, providing the information specified in paragraph (I)(5) of this rule.
- (4) The owner or operator of a facility that is subject to this rule, is located in Butler, Clermont, Hamilton or Warren county, and has an initial startup of a storage tank for volatile organic liquids on or after the effective date of this rule shall notify the appropriate Ohio EPA district office or local air agency in writing that the volatile organic liquid storage tank is subject to this rule not later than either the date of initial startup of the the volatile organic liquid storage tank

or sixty days after the effective date of this rule (whichever is later), providing the information specified in paragraph (I)(5) of this rule. The application for a permit-to-install under rule 3745-31-02 of the Administrative Code may be used to fulfill the notification requirements of this paragraph.

~~(1)(5) The owner or operator of a facility that is subject to this rule and that operates a storage tank for volatile organic liquids with an initial startup date before August 25, 2008 shall notify the appropriate Ohio EPA district office or local air agency in writing that the volatile organic liquid storage tank is subject to this rule. The notification, which shall be submitted not later than October 24, 2008 (or within sixty days after the volatile organic liquid storage tank becomes subject to this rule), required in paragraphs (I)(1) to (I)(4) of this rule shall provide the following information:~~

- (a) Name and address of the owner or operator.
- (b) Address (i.e., physical location) of the affected facility.
- (c) Description of the volatile organic liquid storage tank and Ohio EPA emissions unit number (if assigned).
- (d) Identification of the VOC emission requirement, the means of compliance, and the compliance date for the volatile organic liquid storage tank.
- (e) An application for an operating permit or an application for a modification to an operating permit in accordance with Chapter 3745-77 of the Administrative Code (for sources subject to the Title V permit program) or an application for a permit-to-install and operate or an application for a modification to a permit-to-install and operate in accordance with Chapter 3745-31 of the Administrative Code (for sources not subject to the Title V permit program) for each subject process that meets one of the following:
 - (i) The process does not possess an effective operating permit or permit-to-install and operate.
 - (ii) The process possesses an effective operating permit or permit-to-install and operate and the owner or operator cannot certify in writing to the director that such subject process is in compliance with this rule. An application for an operating permit or permit-to-install and operate is not required provided the subject process is operating under an effective permit and certifies compliance. Such

certification shall include all compliance certification requirements under paragraph (H) of this rule.

[Comment: Applications for sources not subject to Chapter 3745-77 of the Administrative Code, requiring submittal prior to June 30, 2008, were submitted in accordance with Chapter 3745-35 of the Administrative Code.]

~~(2) The owner or operator of a facility that is subject to this rule and that has a volatile organic liquid storage tank with an initial start-up date on or after August 25, 2008 shall notify the appropriate Ohio EPA district office or local air agency in writing that the volatile organic liquid storage tank is subject to this rule. The notification, which shall be submitted not later than either the date of initial startup of the volatile organic liquid storage tank or October 24, 2008 (whichever is later), shall provide the information listed under paragraph (I)(1) of this rule. The application for an installation permit under rule 3745-31-02 of the Administrative Code may be used to fulfill the notification requirements of this paragraph.~~

Effective: 3/27/2022
Five Year Review (FYR) Dates: 11/29/2021 and 11/29/2026

CERTIFIED ELECTRONICALLY

Certification

03/17/2022

Date

Promulgated Under: 119.03
Statutory Authority: 3704.03(E)
Rule Amplifies: 3704.03(A), 3704.03(E)
Prior Effective Dates: 08/25/2008, 04/02/2009, 05/12/2011, 10/15/2015

3745-21-22

Control of volatile organic compound emissions from offset lithographic printing and letterpress printing facilities.

[Comment: For dates and availability of non-regulatory government publications, publications of recognized organizations and associations, federal rules, and federal statutory provisions referenced in this rule, see paragraph (JJ) of rule 3745-21-01 of the Administrative Code titled "referenced materials."]

(A) Paragraphs (B) to (I) of this rule shall apply to each lithographic printing or letterpress printing facility that meets all the following criteria:

- (1) The facility is located in Ashtabula, Butler, Clermont, Cuyahoga, Geauga, Hamilton, Lake, Lorain, Medina, Portage, ~~or~~ Summit, or Warren county.
- (2) The facility employs letterpress printing or one or more of the following types of offset lithographic printing processes: heatset web, non-heatset web or sheet-fed.
- (3) The facility has total actual VOC emissions, before the application of control systems and devices, from all lithographic or letterpress printing operations (including emissions from cleaning solutions used on lithographic or letterpress printing presses and fountain solutions) equal to or greater than three tons of VOCs per rolling twelve-month period.

(B) Exemptions.

- (1) The following operations are exempt from the fountain solution requirements as contained in paragraph (D)(3)(b) of this rule:
 - (a) Any sheet-fed press with a maximum sheet size eleven by seventeen inches or smaller.
 - (b) Any press with a total fountain solution reservoir capacity of less than one gallon.
- (2) The following operations are exempt from the requirement to install add-on controls as contained in paragraph (D)(1) of this rule:
 - (a) Any heatset web press with a maximum web width of 22.0 inches or less.
 - (b) Any heatset web press with potential VOC emissions from ink oil less than or equal to twenty-five tons per year before the application of controls.
 - (c) Any heatset web press used for book printing.

(C) Definitions.

The definitions applicable to this rule are contained in paragraphs (W) and (DD) of rule 3745-21-01 of the Administrative Code.

(D) VOC emissions control.

- (1) Any person who owns or operates a subject heatset web offset lithographic or heatset web letterpress printing press with potential VOC ink oil emissions from the press dryer that are greater than twenty-five tons per year before the application of control systems and devices shall maintain the dryer air pressure lower than the pressroom air pressure at all times the press is operating and operate a control system that meets one of the following for that press:
 - (a) For a control system first installed before April 2, 2009 the control system shall reduce VOC emissions from each dryer by at least ninety per cent or maintain a maximum VOC outlet concentration of twenty ppmv, as hexane (C_6H_{14}) on a dry basis, whichever is less stringent.
 - (b) For a control system first installed on or after April 2, 2009, the control system shall reduce VOC emissions from each dryer by at least ninety-five per cent or maintain a maximum VOC outlet concentration of twenty ppmv as hexane (C_6H_{14}) on a dry basis, whichever is less stringent.
- (2) Any person who owns or operates a subject heatset web offset lithographic printing press shall meet one of the following for the fountain solution used on that press:
 - (a) If the fountain solution contains only alcohol substitutes, maintain the as-applied VOC content of the fountain solution at or below 5.0 per cent, by weight, and use no alcohol in the fountain solution.
 - (b) If the fountain solution contains alcohol, either of the following:
 - (i) Maintain the as-applied VOC content of the fountain solution at or below 1.6 per cent, by weight.
 - (ii) Maintain the as-applied VOC content of the fountain solution at or below 3.0 per cent, by weight, and refrigerate the fountain solution to sixty degrees Fahrenheit or less.
- (3) Any person who owns or operates a subject sheet-fed offset lithographic printing press shall meet one of the following for the fountain solution used on that press:

- (a) If the fountain solution contains only alcohol substitutes, maintain the as-applied VOC content of the fountain solution at or below 5.0 per cent, by weight.
- (b) If the fountain solution contains alcohol, either of the following:
 - (i) Maintain the as-applied VOC content of the fountain solution at or below 5.0 per cent, by weight.
 - (ii) Maintain the as-applied VOC content of the fountain solution at or below 8.5 per cent, by weight, and refrigerate the fountain solution to sixty degrees Fahrenheit or less.
- (4) Anyone who owns or operates a subject non-heatset web offset lithographic printing press shall maintain the as-applied VOC content of the fountain solution used on that press at or below 5.0 per cent, by weight, and use no alcohol in the fountain solution.
- (5) Where it can be demonstrated to the satisfaction of the director that a subject offset lithographic printing press cannot be operated with fountain solutions meeting the limits in paragraph (D)(2), (D)(3), or (D)(4) of this rule for reasons of technological or economic feasibility the permitting authority may establish site-specific limits based upon evidence of technological or economic infeasibility subject to approval by USEPA as a state implementation plan revision.
- (6) Any person who owns or operates a subject offset lithographic or letterpress printing press shall meet one of the following for each cleaning solution used for cleaning on that press:
 - (a) Maintain the as-applied VOC content at or below seventy per cent, by weight.
 - (b) Maintain the as-applied VOC composite partial vapor pressure at or below ten mm Hg at twenty degrees Celsius (sixty-eight degrees Fahrenheit).

The use of cleaning solutions that do not meet paragraphs (D)(6)(a) and (D)(6)(b) of this rule is permitted provided that the quantity used does not exceed one hundred ten gallons over any consecutive twelve-month period.
- (7) Any person who owns or operates a subject offset lithographic or letterpress printing press shall keep all solvent containers closed at all times unless filling, draining, or performing cleanup operations.

- (8) Any person who owns or operates a subject offset lithographic or letterpress printing press shall keep all solvent-laden shop towels in closed containers when not being used.

(E) Compliance dates.

- (1) The owner or operator of an offset lithographic or letterpress printing facility that is subject to this rule shall comply with this rule no later than the following dates:
- (a) For any subject offset lithographic or letterpress printing press located in Ashtabula, Cuyahoga, Geauga, Lake, Lorain, Medina, Portage, or Summit county for which installation commenced before April 2, 2009, the compliance date for the press is ~~twelve months from~~ April 2, ~~2009~~2010.
 - (b) For any subject offset lithographic or letterpress printing press located in Ashtabula, Cuyahoga, Geauga, Lake, Lorain, Medina, Portage, or Summit county for which installation commenced on or after April 2, 2009, the compliance date for the press is the initial startup date of the press.
 - (c) For any subject offset lithographic or letterpress printing press located in Butler, Clermont, Hamilton or Warren county for which installation commenced before the effective date of this rule, the compliance date is either March 1, 2023 or the date of initial startup of the press, whichever is later.
 - (d) For any subject offset lithographic or letterpress printing press located in Butler, Clermont, Hamilton or Warren county for which installation commenced on or after the effective date of this rule, the compliance date is the date of initial startup of the press.
- (2) The owner or operator of an offset lithographic or letterpress printing facility that is subject to this rule shall demonstrate compliance with paragraph (D) (1) of this rule by testing the control device on each subject offset lithographic or letterpress printing press in accordance with paragraph (F)(1) of this rule according to the following:
- (a) For any offset lithographic or letterpress printing facility subject to paragraph (E)(1)(a) of this rule, by no later than ninety days after the press's compliance date. In addition, the Ohio EPA may accept the results of an emission test conducted prior to April 2, 2009, if the

owner or operator provides information and data to the Ohio EPA which demonstrate that an approved USEPA emission test method was employed, that the operation of the press was consistent with the current operating conditions and operating capacity, and that if the Ohio EPA had requested to witness the test, the test was witnessed by the Ohio EPA or local air agency.

(b) For any offset lithographic or letterpress printing facility subject to paragraph (E)(1)(b) of this rule, within one hundred eighty days after the press's compliance date.

(3) Additional testing of a subject offset lithographic or letterpress printing press and the VOC emission control system in accordance with paragraph (F)(1) of this rule may be required by the director to ensure continued compliance.

(F) Compliance test methods.

(1) For any heatset web offset lithographic or heatset web letterpress printing press that is subject to paragraph (D)(1) of this rule, compliance shall be determined by performing emission tests in accordance with the following:

(a) For the purpose of demonstrating compliance with the emission control requirements paragraph (D)(1) of this rule, the affected source shall be run at typical operating conditions and flow rates compatible with scheduled production during any emission testing.

(b) The negative dryer pressure shall be established during the initial test using an airflow direction indicator, such as a smoke stick or aluminum ribbons, or differential pressure gauge. Capture efficiency and continuous dryer air flow monitoring is not required.

(c) The following USEPA test methods (in 40 CFR part 60, appendix A) shall be used to demonstrate compliance with the applicable emission control requirement in paragraph (D)(1) of this rule:

(i) USEPA method 1 or 1A, as appropriate, shall be used to select the sampling sites.

(ii) USEPA method 2, 2A, 2C, or 2D, as appropriate, shall be used to determine the velocity and volumetric flow rate of the exhaust stream.

(iii) USEPA method 3 or 3A, as appropriate, shall be used to determine the concentration of O₂ and CO₂.

- (iv) USEPA method 4 shall be used to determine moisture content.
- (v) USEPA method 18, 25, or 25A shall be used to determine the VOC concentration of the exhaust stream entering and exiting the control device, unless the alternate limit of twenty ppmv as specified in paragraphs (D)(1)(a) and (D)(1)(b) of this rule is being met, in which case only the VOC concentration of the exit exhaust shall be determined. In cases where the anticipated outlet VOC concentration of the control device is less than fifty ppmv as carbon, USEPA method 25A shall be used.
 - (a) If the average concentrations in the outlet of a thermal or catalytic oxidizer measured by USEPA method 25A are found to be greater than fifty ppmv as carbon, USEPA method 18 or 25 may be used to determine non-VOC components (methane and ethane) to correct the outlet VOC readings, unless the director determines that the uncorrected USEPA method 25A results are acceptable.
 - (b) A compliance test shall consist of up to three separate runs, each lasting a minimum of sixty minutes, unless the director determines that process variables dictate shorter sampling times.
 - (c) USEPA method 25 specifies a minimum probe temperature of two hundred sixty-five degrees Fahrenheit. To prevent condensation, the probe should be heated to at least the gas stream temperature, typically close to three hundred fifty degrees Fahrenheit.
 - (d) USEPA method 25A specifies a minimum temperature of two hundred twenty degrees Fahrenheit for the sampling components leading to the analyzer. To prevent condensation when testing heatset web offset presses, the sampling components and flame ionization detector block should be heated to at least the gas stream temperature, typically close to three hundred fifty degrees Fahrenheit.
 - (e) The use of an adaptation to any of the analytical methods specified above shall be approved by the director and USEPA on a case-by-case basis. The owner or operator shall submit sufficient documentation for the director and USEPA to find that the analytical methods specified above

will yield inaccurate results and that the proposed adaptation is appropriate.

- (2) For any offset lithographic printing press that is subject to paragraph (D)(2), (D)(3), or (D)(4) of this rule, compliance with the VOC content of the as-applied fountain solution shall be determined by one of the methods in paragraphs (F)(2)(a) to (F)(2)(c) of this rule except when paragraph (F)(2)(d) is applicable:
- (a) USEPA method 24 shall be used to determine the VOC content of the as-applied fountain solution.
 - (b) If diluted prior to use, a calculation shall be performed for VOC content that combines USEPA method 24 analytical data for the concentrated materials used to prepare the as-applied fountain solution and the proportions in which they are mixed to make the as-applied fountain solution. The analysis of the concentrated material may be performed by the supplier of that material. The analytical data may be derived from a material safety data sheet (MSDS) or equivalent information from the supplier as long as it is based on USEPA method 24 results.
 - (c) If not diluted prior to use, the owner or operator shall use formulation information provided by the supplier, such as a MSDS sheet or equivalent information from the supplier. In the event of a dispute between information provided by the supplier and data obtained by USEPA method 24, the data obtained by USEPA method 24 shall be employed.
 - (d) For any offset lithographic printing press that is subject to paragraph (D)(2)(b) or (D)(3)(b) of this rule, when adding alcohol to a fountain solution batch previously tested in accordance with one of the compliance test methods contained in paragraphs (F)(2)(a) to (F)(2)(c) of this rule, in lieu of the methods in paragraphs (F)(2)(a) to (F)(2)(c) of this rule, the owner or operator shall determine the VOC (alcohol) content of the altered fountain solution using a hydrometer.
- (3) For any offset lithographic printing press that is subject to the fountain solution temperature requirements of paragraph (D)(2)(b)(ii) or (D)(3)(b)(ii) of this rule, a thermometer or other temperature detection device capable of reading to 0.5 degrees Fahrenheit shall be used to ensure that any refrigerated fountain solution reservoirs are maintained at or below sixty degrees Fahrenheit at all times.

- (4) For any offset lithographic or letterpress printing press that is subject to paragraph (D)(6)(a) of this rule, the VOC content of cleaning solutions shall be determined by one of the following methods:
- (a) USEPA method 24 shall be used to determine the VOC content of the cleaning solution.
 - (b) If diluted prior to use, a calculation shall be performed for VOC content that combines USEPA method 24 analytical data for the concentrated materials used to prepare the cleaning solution and the proportions in which they are mixed to make the as-applied cleaning solution. The analysis of the concentrated material may be performed by the supplier of that material. The analytical data may be derived from a material safety data sheet (MSDS) or equivalent information from the supplier as long as it is based on USEPA method 24 results.
 - (c) If not diluted prior to use, the owner or operator shall use formulation information provided by the supplier, such as MSDS sheet or equivalent information from the supplier. In the event of a dispute between information provided by the supplier and data obtained by USEPA method 24, the data obtained by USEPA method 24 shall be employed.
- (5) For any offset lithographic or letterpress printing press that is subject to paragraph (D)(6)(b) of this rule, the VOC composite partial vapor pressure of cleaning solutions shall be determined by one of the following methods:
- (a) If diluted prior to use, calculate the VOC composite vapor pressure of the as-applied solvent by using the formula for "VOC composite vapor pressure" as follows:
 - (i) Determine the identity and quantity of each compound in a blended organic solvent by using ASTM D2306-00, or by using ASTM E260-96(2011) for organics and ASTM D3792-05(2009) for water content, if applicable, or the manufacturer's product formulation data.
 - (ii) Determine the vapor pressure of each pure VOC component by using ASTM D2879-10 or publications such as "Perry's Chemical Engineer's Handbook", "CRC Handbook of Chemistry and Physics", or "Lange's Handbook of Chemistry."
 - (iii) Calculate the VOC composite partial pressure of the solvent by using the formula for "VOC composite partial pressure." For the

purpose of this calculation, the blended solvent shall be assumed to be an ideal solution where "Raoult's Law" applies. The partial vapor pressures of each compound at twenty degrees Celsius (sixty-eight degrees Fahrenheit) shall be used in the formula. The VOC composite partial pressure shall be calculated as follows:

$$PP_c = \sum_{i=1}^n \frac{(W_i)(VP_i) / MW_i}{\frac{W_w}{MW_w} + \frac{W_e}{MW_e} + \sum_{i=1}^n \frac{W_i}{MW_i}}$$

Where:

W_i = Weight of the "i"th VOC compound, in grams.

W_w = Weight of water, in grams.

W_e = Weight of exempt compound, in grams.

MW_i = Molecular weight of the "i"th VOC compound, in grams per gram-mole.

MW_w = Molecular weight of water, in grams per gram-mole.

MW_e = Molecular weight of the "e"th exempt compound, in grams per gram-mole.

PP_c = VOC composite partial vapor pressure at twenty degrees Celsius (sixty-eight degrees Fahrenheit), in mmHg.

VP_i = Vapor pressure of the "i"th VOC compound at twenty degrees Celsius (sixty-eight degrees Fahrenheit), in mmHg.

- (b) If not diluted prior to use, the owner or operator shall use formulation information provided by the supplier, such as a material safety data sheet (MSDS) or equivalent information from the supplier as long as it is based

on results determined in accordance with the procedure under paragraph (F)(5)(a) of this rule.

(G) Monitoring and recordkeeping.

- (1) The owner or operator of an offset lithographic or letterpress printing press that is subject to the control requirements specified in paragraph (D)(1) of this rule, shall install and operate continuous temperature monitoring and recording equipment that measures and records temperature data at least once every fifteen minutes, and shall collect and record the following information and maintain the information at the facility for a period of five years:
 - (a) A log or record of any time when the control device or monitoring equipment is not in operation when any associated press is in operation.
 - (b) For thermal oxidizers all three-hour periods of operation during which the average combustion temperature was more than fifty degrees Fahrenheit below the average combustion temperature during the most recent emission test that demonstrated that the press was in compliance.
 - (c) For catalytic oxidizers all three-hour periods of operation during which the average temperature of the dryer exhaust gases immediately before the catalyst bed was more than fifty degrees Fahrenheit below the average temperature of the dryer exhaust gases during the most recent emission test that demonstrated that the press was in compliance.
 - (d) For catalytic oxidizers, the catalyst bed material shall be inspected annually for general catalyst condition and any signs of potential catalyst depletion. The owner or operator shall also collect a representative sample of the catalyst from the oxidizer, per manufacturer's recommendations, and have it tested to evaluate the catalyst's capability to continue to function at or above the required control efficiency. An evaluation of the catalyst bed material shall be conducted whenever the results of the inspection indicate signs of potential catalyst depletion or poor catalyst condition based on manufacturer's recommendations, but not less than once per year.
- (2) The owner or operator of a heatset web or sheet-fed offset lithographic printing press subject to paragraph (D)(2)(b) or (D)(3)(b) of this rule shall measure the following:
 - (a) In accordance with paragraph (F)(2)(d) of this rule, the VOC (alcohol) content, in per cent by weight, of any altered fountain solution employed

in the press, measured at the time of alteration. The owner or operator shall maintain records of the results of the measurements at the facility for a period of five years. The alcohol content of the fountain solution shall be measured using a hydrometer. The hydrometer shall have a visual, analog, or digital readout with an accuracy of 0.5 per cent; and a standard solution shall be used to calibrate the hydrometer for the type of alcohol used in the fountain solution.

- (b) If the owner or operator refrigerates the fountain solution in accordance with paragraph (D)(2)(b)(ii) or (D)(3)(b)(ii) of this rule, the temperature of the fountain solution, in degrees Fahrenheit, measured on a daily basis. The owner or operator shall maintain records of the results of the measurements at the facility for a period of five years.
- (3) The owner or operator of a subject offset lithographic printing press shall maintain records, for a period of five years, of one of the following for fountain solution preparation:
- (a) For an owner or operator maintaining a recipe log for each batch of fountain solution prepared for use in the press:
 - (i) A recipe log that identifies all recipes used to prepare the as-applied fountain solution. Each recipe shall be maintained in the recipe log for a period of five years from the date the recipe was last prepared for a press. Each recipe shall clearly identify the following:
 - (a) VOC content of each concentrated alcohol substitute, added to make the batch of fountain solution, based upon the manufacturer's laboratory analysis using USEPA method 24.
 - (b) The proportions in which the fountain solution is mixed, including the addition of alcohol or water. The proportion may be identified as a volume when preparing a discrete batch or may be identified as the settings when an automatic mixing unit is employed.
 - (c) The calculated VOC content of the final, mixed recipe.
 - (ii) Identification of the recipe used to prepare each batch of fountain solution for use in the press.
 - (iii) The date and time when the batch was prepared.
 - (iv) An affirmation the batch was prepared in accordance with the recipe.

- (b) For an owner or operator not maintaining a recipe log in accordance with paragraph (G)(3)(a) of this rule, for each batch of fountain solution prepared for use in the press
 - (i) The volume and VOC content of each concentrated alcohol substitute, added to make the batch of fountain solution, based upon the manufacturer's laboratory analysis using USEPA method 24.
 - (ii) The volume of alcohol added to make the batch of fountain solution.
 - (iii) The volume of water added to make the batch of fountain solution.
 - (iv) The calculated VOC content of the final, mixed batch.
 - (v) The date and time the batch was prepared.

For purposes of paragraphs (G)(3)(a) and (G)(3)(b) of this rule, a fountain solution that is continuously blended with an automatic mixing unit is considered to be the same batch until such time that the recipe or mix ratio is changed.

- (4) The owner or operator of a subject offset lithographic or letterpress printing press shall maintain records, for a period of five years, of one of the following for all cleaning solutions employed in all the offset lithographic and letterpress printing operations:
 - (a) For an owner or operator maintaining a recipe log for each batch of cleaning solution prepared:
 - (i) A recipe log that identifies all recipes used to prepare the as-applied cleaning solution. Each recipe shall be maintained in the recipe log for a period of five years from the date the recipe was last prepared. Each recipe shall clearly identify one of the following:
 - (a) The VOC content of each cleaning solution, based upon the manufacturer's laboratory analysis using USEPA method 24.
 - (b) The VOC composite partial vapor pressure of each cleaning solution, based upon the method under paragraph (F)(5) of this rule.
 - (ii) Identification of the recipe used to prepare each batch of cleaning solution.

- (iii) The date and time when the batch was prepared.
 - (iv) An affirmation the batch was prepared in accordance with the recipe.
 - (b) For an owner or operator not maintaining a recipe log in accordance with paragraph (G)(5)(a) of this rule, for each batch of cleaning solution prepared, records of the VOC content or VOC composite partial vapor pressure and the date and time the batch was prepared.
- (5) The owner or operator of a subject offset lithographic or letterpress printing press shall maintain monthly records of the following information:
- (a) The total amount, in gallons, of all the cleaning solutions employed.
 - (b) The total amount, in gallons, of all the cleaning solutions employed that exceeds the allowable VOC content or VOC composite vapor pressure.
- (H) Reporting of monitoring and recordkeeping information.

The owner or operator of an offset lithographic or letterpress printing facility that is subject to this rule shall notify the director of any of the following exceedances of applicable requirements. Each notification shall be submitted to the director within forty-five days after the instance occurs, and the notification shall include a copy of the record showing the instance.

- (1) If determining alcohol content via hydrometer measurement, each hydrometer measurement that shows an exceedance of the applicable alcohol content limitation specified in paragraph (D)(2)(a), (D)(2)(b), (D)(3)(a), or (D)(3)(b) of this rule.
- (2) If complying via refrigerated fountain solution, each temperature reading that shows an exceedance of the temperature limitation specified in paragraph (D)(2)(b) or (D)(3)(b) of this rule.
- (3) Each calculated VOC content that exceeds the VOC content limitation specified in paragraph (D)(2)(b), (D)(3)(b), or (D)(4) of this rule.
- (4) Each instance when an exceedance of the VOC content or VOC composite partial vapor pressure specified in paragraph (D)(6) of this rule for cleaning solutions occurs.
- (5) All three-hour blocks of time during which the average combustion temperature within the thermal oxidizer was below the temperature limitation specified in paragraph (G)(1)(b) of this rule.

- (6) All three-hour blocks of time when the emissions unit was in operation during which the average temperature of the exhaust gases immediately before the catalyst bed was below the temperature limitations specified paragraph (G)(1)(c) of this rule.

(I) Retention factors and capture efficiencies.

For purposes of determining VOC emissions from offset lithographic printing operations, the following retention factors and capture efficiencies shall be used:

- (1) A portion of the VOC contained in inks and cleaning solution is retained in the printed web or in the shop towels used for cleaning. The following retention factors shall be used:
 - (a) A twenty per cent VOC retention factor shall be used for heatset inks printed on absorptive substrates, meaning eighty per cent of the VOC in the ink is emitted during the printing process and is available for capture and control by an add-on pollution control device.
 - (b) A ninety-five per cent VOC retention factor shall be used for sheet-fed and non-heatset web inks printed on absorptive substrates, meaning five per cent of the VOC in the ink is emitted during the printing process.
 - (c) A fifty per cent VOC retention factor shall be used for cleaning solution VOC in shop towels for cleaning solutions with a VOC composite vapor pressure of no more than ten mmHg at twenty degrees Celsius (sixty-eight degrees Fahrenheit) if the contaminated shop towels are kept in closed containers, meaning fifty per cent of the VOC used on the shop towels is emitted during the cleaning process.
- (2) A portion of the VOC contained in inks, fountain solutions, and automatic blanket washes on heatset web presses is captured in the press dryer for control by add-on pollution control devices. The following capture efficiencies shall be used:
 - (a) A one hundred per cent VOC carry over efficiency shall be used for inks. All the VOC in the ink that is not retained is assumed to be volatilized in the press dryer. Capture efficiency testing for heatset dryers is not required if it is demonstrated that pressure in the dryer is negative relative to the surrounding press room and the airflow is into the dryer.
 - (b) A seventy per cent VOC carry over efficiency shall be used for fountain solutions containing alcohol substitutes.

- (c) A forty per cent VOC carry over efficiency shall to be used for automatic blanket wash solutions with a VOC composite vapor pressure of no more than ten mmHg at twenty degrees Celsius (sixty-eight degrees Fahrenheit).

(J) Applicability notification, compliance certification, and permit application.

- (1) The owner or operator of an offset lithographic or letterpress printing facility that is subject to this rule, is located in located in Ashtabula, Cuyahoga, Geauga, Lake, Lorain, Medina, Portage, or Summit county, and has an initial startup of an offset lithographic or letterpress printing press before April 2, 2009 shall notify the appropriate Ohio EPA district office or local air agency in writing that the offset lithographic or letterpress printing press is subject to this rule not later than June 1, 2009 (or within sixty days after the offset lithographic or letterpress printing press becomes subject to this rule), providing the information specified in paragraph (J)(5) of this rule.
- (2) The owner or operator of an offset lithographic or letterpress printing facility that is subject to this rule, is located in Ashtabula, Cuyahoga, Geauga, Lake, Lorain, Medina, Portage, or Summit county, and has an initial startup of an offset lithographic or letterpress printing press on or after April 2, 2009 shall notify the appropriate Ohio EPA district office or local air agency in writing that the offset lithographic or letterpress printing press is subject to this rule not later than either the date of initial startup of the offset lithographic or letterpress printing press or June 1, 2009 (whichever is later), providing the information specified in paragraph (J)(5) of this rule. The application for a permit-to-install under rule 3745-31-02 of the Administrative Code may be used to fulfill the notification requirements of this paragraph.
- (3) The owner or operator of an offset lithographic or letterpress printing facility that is subject to this rule, is located in Butler, Clermont, Hamilton or Warren county, and has an initial startup of an offset lithographic or letterpress printing press before the effective date of this rule shall notify the appropriate Ohio EPA district office or local air agency in writing that the offset lithographic or letterpress printing press is subject to this rule not later than sixty days after the effective date of this rule, providing the information specified in paragraph (J) (5) of this rule.
- (4) The owner or operator of an offset lithographic or letterpress printing facility that is subject to this rule, is located in Butler, Clermont, Hamilton or Warren county, and has an initial startup of an offset lithographic or letterpress printing press on or after the effective date of this rule shall notify the appropriate Ohio EPA district office or local air agency in writing that the offset lithographic

or letterpress printing press is subject to this rule not later than either the date of initial startup of the offset lithographic or letterpress printing press or sixty days after the effective date of this rule (whichever is later), providing the information specified in paragraph (J)(5) of this rule. The application for a permit-to-install under rule 3745-31-02 of the Administrative Code may be used to fulfill the notification requirements of this paragraph.

~~(1)(5) The owner or operator of an offset lithographic or letterpress printing facility that is subject to this rule and that has an offset lithographic or letterpress printing press with an initial startup date before April 2, 2009 of this rule shall notify the Ohio EPA district office or local air agency in writing that the offset lithographic or letterpress printing press is subject to this rule. The notification, which shall be submitted not later than June 1, 2009 (or within sixty days after the offset lithographic or letterpress printing press becomes subject to this rule), required in paragraphs (J)(1) to (J)(4) of this rule shall provide the following information:~~

- (a) Name and address of the owner or operator.
- (b) Address (i.e., physical location) of the offset lithographic printing or letterpress printing facility.
- (c) Equipment description and Ohio EPA application number (if assigned) of the offset lithographic or letterpress printing press.
- (d) Identification of the VOC emission requirement, the means of compliance, and the compliance date for the offset lithographic or letterpress printing press.
- (e) An application for an operating permit or an application for a modification to an operating permit in accordance with Chapter 3745-77 of the Administrative Code (for sources subject to the Title V permit program) or an application for a permit-to-install and operate or an application for a modification to a permit-to-install and operate in accordance with Chapter 3745-31 of the Administrative Code (for sources not subject to the Title V permit program) for each subject process that meets one of the following:
 - (i) The process does not possess an effective operating permit or permit-to-install and operate.
 - (ii) The process possesses an effective operating permit or permit-to-install and operate and the owner or operator cannot certify in

writing to the director that such subject process is in compliance with this rule. An application for an operating permit or permit-to-install and operate is not required provided the subject process is operating under an effective permit and certifies compliance. Such certification shall include all compliance certification requirements under paragraph (J)(36) of this rule.

~~(2) The owner or operator of an offset lithographic or letterpress printing facility that is subject to this rule and that has an offset lithographic or letterpress printing press with an initial startup date on or after April 2, 2009 of this rule shall notify the Ohio EPA district office or local air agency in writing that the offset lithographic or letterpress printing press is subject to this rule. The notification, which shall be submitted not later than either the date of initial startup of the offset lithographic or letterpress printing press, or June 1, 2009 (whichever is later), shall provide the information listed under paragraph (J)(1) of this rule. The application for an installation permit under rule 3745-31-02 of the Administrative Code may be used to fulfill the notification requirements of this paragraph.~~

~~(3)(6)~~ Compliance certification.

- (a) The owner or operator of an offset lithographic or letterpress printing facility that is subject to this rule shall notify the Ohio EPA district office or local air agency in writing within thirty days following the completion of any of the following:
- (i) For an offset lithographic or letterpress printing press subject to the VOC emission requirements in paragraphs (D)(2) to (D)(8) of this rule, the first documented achievement of compliance with each of the requirements.
 - (ii) For an offset lithographic or letterpress printing press subject to the VOC emission control requirement in paragraph (D)(1) of this rule, the following:
 - (a) The completion of installation and initial use of a VOC emission control system for the offset lithographic or letterpress printing press.
 - (b) The completion of installation and initial use of any monitoring devices required under paragraph (G) of this rule for the offset lithographic printing press.

(c) The completion of any compliance testing conducted in accordance with paragraph (F) of this rule to demonstrate compliance with the applicable control requirement.

(b) The compliance certification under paragraph (J)(36)(a) of this rule shall provide the following, where applicable:

- (i) A description of the requirements.
- (ii) A description of the VOC emission control system.
- (iii) A description of the monitoring devices.
- (iv) A description of the records that document continuing compliance.
- (v) The results of any compliance tests, including documentation of test data.
- (vi) The results of any records that document continuing compliance, including calculations.
- (vii) A statement by the owner or operator of the offset lithographic or letterpress printing facility as to whether the offset lithographic or letterpress printing press has complied with the requirements.

(K) Requirements for an owner or operator of an offset lithographic or letterpress printing facility that determines the facility is not subject to one or more of the control requirements in paragraph (D) of this rule.

(1) When establishing that the facility's total actual VOC emissions, before the application of control systems and devices, from all lithographic or letterpress printing operations (including emissions from cleaning solutions used on lithographic or letterpress printing presses and fountain solutions) are less than three tons of VOCs per rolling twelve-month period and, therefore, the facility is not subject to the add-on control, cleaning solvent and fountain solution requirements in paragraphs (D)(1) to (D)(8) of this rule, the owner or operator shall maintain one of the following records:

(a) Monthly records of material usage demonstrating the following thresholds have not been exceeded:

Type of Letterpress or Offset Lithographic Printing Operation	12-Month Rolling Threshold
---	----------------------------

Sheet-fed only	768 gallons of cleaning solvent and fountain solution additives
Non-heatset Web only	768 gallons of cleaning solvent and fountain solution additives
Combination of Sheet-fed and Non-heatset Web	768 gallons of cleaning solvent and fountain solution additives.
Heatset Web only	5400 pounds of ink, cleaning solvent and fountain solution additives

A facility that employs a combination of printing technologies that includes a heatset web offset lithographic printing press may not use this option for demonstrating actual emissions are less than three tons of VOCs per rolling twelve-month period.

- (b) The following monthly records and calculations demonstrating actual emissions did not equal or exceed three tons of VOCs per rolling twelve-month period:
- (i) The total gallons of each cleaning solvent used.
 - (ii) The VOC content of each cleaning solvent.
 - (iii) The total gallons of each fountain solution used.
 - (iv) The VOC content of each fountain solution.
 - (v) The total pounds of each ink used.
 - (vi) The VOC content of each ink.

VOC calculations shall be based on the following formula using applicable retention factors identified in paragraph (I)(1) of this rule:

VOC emissions = amount of ink (pounds) x VOC content (weight fraction) x (1 - retention factor, as a fraction) + amount of fountain solution (gallons) x VOC content (pounds per gallon) + amount of cleaning solvent (gallons) x VOC content (pounds per gallon) x (1 - retention factor, as a fraction).

- (2) When establishing that the heatset web offset lithographic or heatset web letterpress printing press potential VOC ink oil emissions, before control,

from the press dryer of any heatset web offset lithographic printing press or heatset web letterpress printing press are less than twenty-five tons per year and, therefore, the facility is not subject to the add-on control requirements in paragraph (D)(1) of this rule, the owner or operator shall maintain the following records on a monthly basis for each such press:

- (a) The total pounds of each ink used.
 - (b) The VOC content of each ink.
 - (c) The hours of operation of each press.
- (3) If an owner or operator of an offset lithographic or letterpress printing facility determines they are subject to one or more of the control requirements in paragraph (D) of this rule based on the records required under paragraph (J) of this rule, the owner or operator shall comply with said requirements of this rule.

Effective: 3/27/2022
Five Year Review (FYR) Dates: 11/29/2021 and 11/29/2026

CERTIFIED ELECTRONICALLY

Certification

03/17/2022

Date

Promulgated Under: 119.03
Statutory Authority: 3704.03(E)
Rule Amplifies: 3704.03(A), 3704.03(E)
Prior Effective Dates: 04/02/2009, 02/10/2010, 10/15/2015

3745-21-23

Control of volatile organic compound emissions from industrial solvent cleaning operations.

[Comment: For dates and availability of non-regulatory government publications, publications of recognized organizations and associations, federal rules, and federal statutory provisions referenced in this rule, see paragraph (JJ) of rule 3745-21-01 of the Administrative Code titled "referenced materials."]

(A) Applicability.

(1) Paragraphs (B) to (I) of this rule shall apply to any facility that meets all of the following criteria:

(a) The facility is located in Ashtabula, Butler, Clermont, Cuyahoga, Geauga, Hamilton, Lake, Lorain, Medina, Portage, ~~or~~ Summit, or Warren county.

(b) The facility employs solvent materials in solvent cleaning operations during the production, repair, maintenance, or servicing of parts, products, tools, machinery, equipment, or general work areas, and stores or disposes of these solvent materials.

(c) The total actual VOC emissions from all of the solvent cleaning operations at the facility, other than cleaning operations exempt pursuant to paragraphs (A)(2), (D)(1) and (D)(2) of this rule, are equal to or greater than 3.0 tons per twelve-month rolling period before the application of capture systems and control devices.

(2) This rule shall not apply to cleaning operations in the following source categories listed for regulation under Section 183(e) of the Clean Air Act:

(a) Aerospace coatings.

(b) Flexible package printing materials.

(c) Lithographic printing materials.

(d) Letterpress printing materials.

(e) Flat wood paneling coatings.

(f) Large appliance coatings.

(g) Metal furniture coatings.

(h) Paper film and foil coatings.

- (i) Wood furniture coatings.
- (j) Shipbuilding and repair coatings.
- (k) Plastic parts coatings.
- (l) Miscellaneous metals parts coatings.
- (m) Fiberglass boat manufacturing materials.
- (n) Miscellaneous industrial adhesives.
- (o) Auto and light-duty truck assembly coatings.

(B) Definitions.

The definitions applicable to this rule are contained in paragraphs (A), (B), and (EE) of rule 3745-21-01 of the Administrative Code.

(C) VOC emission controls.

(1) VOC-content limitations.

The owner or operator of a facility that is subject to this rule shall not use a solvent to perform solvent cleaning operations unless the solvent complies with the applicable VOC-content limitation specified in the following table:

Table of standards

Solvent Cleaning Operation		VOC-Content Limitation [in pounds per gallon, as employed]
(A)	Product cleaning during manufacturing process or surface preparation for coating, adhesive, or ink application:	
	(1) General	0.42
	(2) Electrical apparatus components and electronic components	0.83
	(3) Medical devices and pharmaceuticals	6.7
(B)	Repair and maintenance cleaning:	

	(1)	General	0.42
	(2)	Electrical apparatus components and electronic components	0.83
	(3)	Medical devices and pharmaceuticals:	
	(a)	Tools, equipment and machinery	6.7
	(b)	General work surfaces	5.0
(C)		Cleaning of coating or adhesive application equipment	0.42
(D)		Cleaning of ink application equipment:	
	(1)	General	0.42
	(2)	Flexographic printing	0.42
	(3)	Gravure printing:	
	(a)	Publication	0.83
	(b)	Packaging	0.42
	(4)	Screen printing	4.2
	(5)	Ultraviolet ink and electron beam ink application equipment, except screen printing	5.4
	(6)	Specialty flexographic printing	0.83
(E)		Cleaning of polyester resin application equipment not subject to 40 CRF part 63 subpart WWWW	0.42

(2) Cleaning devices and methods.

The owner or operator of a facility that is subject to this rule shall employ only the following cleaning devices and methods:

(a) Wipe cleaning.

(b) Closed containers or hand held spray bottles from which solvents are applied without a propellant-induced force.

- (c) Cleaning equipment which has a solvent container that can be, and is closed during cleaning operations, except when depositing and removing objects to be cleaned, and is closed during non-operation with the exception of maintenance and repair to the cleaning equipment itself.
 - (d) Remote reservoir cleaner, if the operator of the cleaner complies with all of the following:
 - (i) Prevents solvent vapors from escaping from the solvent container by using such devices as a cover or a valve when the remote reservoir is not being used, cleaned, or repaired.
 - (ii) Directs solvent flow in a manner that will prevent liquid solvent from splashing outside of the remote reservoir cleaner.
 - (iii) Does not clean porous or absorbent materials, such as cloth, leather, wood, or rope.
 - (iv) Uses only solvent containers free of all liquid leaks. Auxiliary equipment, such as pumps, pipelines, or flanges, shall not have any liquid leaks, visible tears, or cracks. Any liquid leak, visible tear, or crack detected shall be repaired within one calendar day, or the leaking section of the remote reservoir cold cleaner shall be drained of all solvent and shut down until it is replaced or repaired.
 - (e) Non-atomized solvent flow method where the cleaning solvent is collected in a container or a collection system which is closed except for solvent collection openings and, if necessary, openings to avoid excessive pressure build-up inside the container.
 - (f) Solvent flushing method where the cleaning solvent is discharged into a container which is closed except for solvent collection openings and, if necessary, openings to avoid excessive pressure build-up inside the container. The discharged solvent from the equipment must be collected into containers without atomizing into the open air. The solvent may be flushed through the system by air or hydraulic pressure, or by pumping.
- (3) The owner or operator of a facility that is subject to this rule is prohibited from atomizing any solvent unless the emissions are vented to VOC emission control equipment that meets paragraph (C)(5) of this rule.
- (4) Storage and disposal.

All VOC-containing solvents used in solvent cleaning operations shall be stored in non-absorbent, non-leaking containers which shall be kept closed at all times except when filling or emptying. It is recommended that cloth and paper moistened with VOC-containing solvents be stored in closed, non-absorbent, non-leaking containers.

(5) Control equipment.

In lieu of complying with paragraphs (C)(1) and (C)(2) of this rule for a solvent cleaning operation, the owner or operator of a facility that is subject to this rule may comply with this rule by installing and operating VOC emission control equipment for the solvent cleaning operation. The VOC emission control equipment shall comply with all of the following:

- (a) A capture efficiency of at least ninety per cent, by weight, for the VOC emissions.
- (b) Either a destruction efficiency of at least ninety-five per cent, by weight, for the VOC emissions or an outlet concentration of less than fifty parts per million, by volume, dry basis, for the VOC emissions.

(6) Alternate compliance option.

(a) In lieu of complying with the requirements in paragraph (C)(1) of this rule, the owner or operator of a facility may use solvents or solvent solutions for industrial cleaning operations which have a VOC composite partial vapor pressure of less than or equal to eight mm of Hg at twenty degrees Celsius.

(b) In lieu of complying with paragraphs (C)(1) and (C)(2) of this rule, a manufacturer of coatings, inks, resins or adhesives may comply with the following:

(i) Clean portable or stationary mixing vats, high dispersion mills, grinding mills, tote tanks and roller mills by one or more of the following methods:

(a) Use a cleaning solvent that either contains less than 1.67 pounds per gallon of VOC or has a composite vapor pressure no more than eight mm of Hg at twenty degrees Celsius.

(b) Comply with the following work practices:

(i) Equipment being cleaned must be maintained leak free.

- (ii) VOC-containing cleaning materials must be drained from the cleaned equipment upon completion of cleaning.
 - (iii) VOC-containing cleaning materials, including waste solvent, shall not be stored or disposed of in such a manner that will cause or allow evaporation into the atmosphere.
 - (iv) Store all VOC-containing cleaning materials in closed containers.
 - (c) Collect and vent the emissions from equipment cleaning to a VOC emission control system that has an overall capture and control efficiency of at least eighty per cent, by weight, for the VOC emissions. Where such reduction is achieved by incineration, at least ninety per cent of the organic carbon shall be oxidized to carbon dioxide.
 - (d) Use organic solvents other than those allowed in paragraph (C) (6)(b)(i)(a) of this rule provided no more than sixty gallons of fresh solvent shall be used per month. Organic solvent that is reused or recycled (either on-site or off-site), for further use in equipment cleaning or the manufacture of coating, ink, or adhesive shall not be included in this limit. Also, store all VOC-containing cleaning materials in closed containers.
 - (ii) When using solvent for wipe cleaning, the owner or operator of a facility shall do the following:
 - (a) Not use open containers for the storage or disposal of cloth or paper impregnated with organic compounds that is used for cleanup, or coating, ink, or adhesive removal.
 - (b) Not store spent or fresh organic compounds to be used for cleanup or coating, ink, or adhesive removal in open containers.

(D) Exemptions.

(1) The following solvent cleaning operations are exempt from this rule:

- (a) Any solvent cleaning operation that is subject to paragraph (O) of rule 3745-21-09 of the Administrative Code.

- (b) Janitorial cleaning, including graffiti removal.
 - (c) Stripping of cured coatings, cured ink, or cured adhesives.
 - (d) Cleaning operations in printing pre-press or graphic arts pre-press areas, including the cleaning of film processors, color scanners, plate processors, film cleaning, and plate cleaning.
 - (e) Cleaning operations associated with digital printing.
- (2) The following solvent cleaning operations are exempt from the VOC-content limitations specified in paragraph (C)(1) of this rule:
- (a) Cleaning of solar cells, laser hardware, scientific instruments, and high-precision optics.
 - (b) Cleaning conducted as part of the following: performance laboratory tests on coatings, adhesives, or inks; research and development programs; and laboratory tests in quality assurance laboratories.
 - (c) Cleaning of paper-based gaskets and clutch assemblies where rubber is bonded to metal by means of an adhesive.
 - (d) Cleaning of cotton swabs to remove cottonseed oil before cleaning of high-precision optics.
 - (e) Medical device and pharmaceutical facilities using up to 1.5 gallons per day of solvents.
 - (f) Cleaning of adhesive application equipment used for thin metal laminating.
 - (g) Cleaning of electronic or electrical cables.
 - (h) Touch-up cleaning performed on printed circuit boards where surface mounted devices have already been attached.
 - (i) Cleaning of coating and adhesive application processes utilized to manufacture transdermal drug delivery product using less than three gallons per day of ethyl acetate.
 - (j) Cleaning of application equipment used to apply coatings on satellites and radiation effect coatings.
 - (k) Cleaning of application equipment used to apply solvent-borne fluoropolymer coatings.

- (l) Cleaning of ultraviolet or electron beam adhesive application.
 - (m) Cleaning of sterilization indicating ink application equipment if the facility employs less than 1.5 gallons per day of solvents for such cleaning.
 - (n) Cleaning of metering rollers, dampening rollers and printing plates.
 - (o) Cleaning of polyester resin application equipment for sources subject to 40 CFR part 63, subpart WWWW.
 - (p) Cleaning of polyester resin application equipment for sources subject to 40 CFR part 63, subpart VVVV or rule 3745-21-27 of the Administrative Code.
- (3) The following solvent cleaning operations are exempt from paragraph (C)(3) of this rule:
- (a) Cleaning of the nozzle tips of automated spray equipment systems, except for robotic systems.
 - (b) Cleaning with spray bottles or containers described in paragraph (C)(2)(b) of this rule.
 - (c) Printing operations where the roller or blanket wash is applied automatically.
- (4) Cleaning with aerosol products shall be exempt from paragraphs (C)(1) and (C)(3) of this rule if the facility employs 1.25 gallons (one hundred sixty fluid ounces) or less of the aerosol products per day.

(E) Compliance dates.

- (1) The owner or operator of a facility that is subject to this rule shall comply with this rule no later than the following dates:
- (a) For any solvent cleaning operation located in Ashtabula, Cuyahoga, Geauga, Lake, Lorain, Medina, Portage, or Summit county which commenced operation before April 2, 2009, the compliance date for the operation is the initial startup date of the solvent cleaning operation or April 2, 2010, whichever is later.
 - (b) For any solvent cleaning operation located in Ashtabula, Cuyahoga, Geauga, Lake, Lorain, Medina, Portage, or Summit county which

commenced operation on or after April 2, 2009, the compliance date for the operation is the initial startup date of the solvent cleaning operation.

(c) For any solvent cleaning operation located in Butler, Clermont, Hamilton or Warren county for which installation commenced before the effective date of this rule, the compliance date is either March 1, 2023 or the date of initial startup of the solvent cleaning operation, whichever is later.

(d) For any solvent cleaning operation located in Butler, Clermont, Hamilton or Warren county for which installation commenced on or after the effective date of this rule, the compliance date is the date of initial startup of the solvent cleaning operation.

(2) If an owner or operator of a solvent cleaning operation that is subject to this rule employs VOC emission control equipment to comply with this rule, pursuant to paragraph (C)(5) of this rule, the owner or operator shall demonstrate compliance with paragraph (C)(5) of this rule by testing the VOC emission control equipment in accordance with paragraph (F)(2) of this rule within ninety days after the compliance date for the solvent cleaning operation.

(3) Additional testing of the VOC emission control equipment for a solvent cleaning operation in accordance with paragraph (F)(2) of this rule may be required by the director to ensure continued compliance.

(F) Compliance test methods.

(1) For any solvent cleaning operation that is subject to paragraph (C)(1) of this rule, USEPA method 24, or formulation data from the solvent material supplier, shall be used to determine the VOC content of the solvent material employed in the solvent cleaning operation. In the event of a conflict between the solvent material formulation data and data obtained by method 24, the method 24 results will take precedence.

(2) For any solvent cleaning operation that is subject to paragraph (C)(5) or (C)(6) of this rule, compliance shall be determined by performing emission tests in accordance with the following:

(a) The general provisions specified under paragraphs (A)(2) to (A)(5) of rule 3745-21-10 of the Administrative Code shall apply to the compliance testing.

(b) The test methods and procedures of paragraph (C) of rule 3745-21-10 of the Administrative Code shall be followed.

(3) Determination of vapor pressure.

The composite partial pressure of solvents shall be determined by the following:

- (a) Determining the identity and quantity of each compound in a blended organic solvent by using ASTM D2306-00, or by using ASTM E260-96(2011) for organics and ASTM D3792-05(2009) for water content, if applicable, or the manufacturer's product formulation data; and
- (b) Determining the vapor pressure of each pure VOC component by using ASTM D2879-10 or from publications such as "Perry's Chemical Engineer's Handbook", "CRC Handbook of Chemistry and Physics", or "Lange's Handbook of Chemistry;" and
- (c) Calculating the composite partial pressure of the solvent by using the formula for composite partial pressure. For the purpose of this calculation, the blended solvent shall be assumed to be an ideal solution where "Raoult's Law" applies. The partial pressures of each compound at twenty degrees Celsius (sixty-eight degrees Fahrenheit) shall be used in the formula.

The VOC composite partial pressure is calculated as follows:

$$PP_c = \sum_{i=1}^n \frac{(W_i)(VP_i) / MW_i}{\frac{W_w}{MW_w} + \frac{W_e}{MW_e} + \sum_{i=1}^n \frac{W_i}{MW_i}}$$

Where:

W_i = Weight of the "i"th VOC compound, in grams.

W_w = Weight of water, in grams.

W_e = Weight of exempt compound, in grams.

MW_i = Molecular weight of the "i"th VOC compound, in grams per gram-mole.

MW_w = Molecular weight of water, in grams per gram-mole.

MW_e = Molecular weight of the "e"th exempt compound, in grams per gram-mole.

PP_c = VOC composite partial pressure at twenty degrees Celsius (sixty-eight degrees Fahrenheit), in mmHg.

VP_i = Vapor pressure of the "i"th VOC compound at twenty degrees Celsius (sixty-eight degrees Fahrenheit), in mmHg.

(G) Monitoring and recordkeeping.

- (1) The owner or operator of a solvent cleaning operation that is subject to one or more of the VOC-content limitations specified in paragraph (C)(1) of this rule shall collect and record the following information each month for each cleaning material subject to a VOC-content limitation and shall maintain the information at the facility for a period of five years:
 - (a) The name and identification of each cleaning material and the associated solvent cleaning activity.
 - (b) The VOC content, based upon USEPA method 24, of each cleaning material, in pounds per gallon of material, as employed or the VOC composite partial vapor pressures of the solvents or solvent solutions used in the industrial cleaning operations.
- (2) If an owner or operator of a solvent cleaning operation is subject to paragraph (C)(5) or (C)(6) of this rule and employs a thermal incinerator or catalytic incinerator to achieve and maintain compliance, the owner or operator shall comply with the following:
 - (a) Continuous temperature monitoring and continuous temperature recording equipment shall be installed and operated to accurately measure the operating temperature for the control device.
 - (b) The following information shall be collected and recorded each day of operation of the solvent cleaning operation and the control device, and the information shall be maintained at the facility for a period of five years:

- (i) A log or record of the operating time for the control device, monitoring equipment, and the associated solvent cleaning operation.
 - (ii) For thermal incinerators, all three-hour periods of operation during which the average combustion temperature was more than fifty degrees Fahrenheit below the average combustion temperature during the most recent emission test that demonstrated that the solvent cleaning operation was in compliance.
 - (iii) For catalytic incinerators, all three-hour periods of operation during which the average temperature of the dryer exhaust gases immediately before the catalyst bed was more than fifty degrees Fahrenheit below the average temperature of the dryer exhaust gases during the most recent emission test that demonstrated that the solvent cleaning operation was in compliance, and one of the following:
 - (a) All three-hour periods during which the average temperature difference across the catalyst bed was less than eighty per cent of the average temperature difference during the most recent emission test that demonstrated that the solvent cleaning operation was in compliance.
 - (b) Records required by an inspection and maintenance plan for the catalytic incinerator that meets paragraph (G)(8) of this rule.
- (3) If an owner or operator of a solvent cleaning operation is subject to paragraph (C)(5) or (C)(6) of this rule and employs a carbon adsorption system to achieve and maintain compliance, the owner or operator shall comply with the following:
- (a) One of the following types of monitoring and recording equipment shall be installed and operated for the carbon adsorption system:
 - (i) A continuous emission monitoring and recording system that is capable of accurately measuring and recording the concentration of organic compounds in the exhaust gases from the carbon adsorption system.
 - (ii) Monitoring and recording equipment that are capable of accurately measuring and recording the total mass steam flow rate for each regeneration cycle of each carbon bed.

- (iii) Monitoring and recording equipment that are capable of accurately measuring and recording the temperature of each carbon bed after regeneration (and after completion of any cooling cycle).
- (b) The following information shall be collected and recorded each day of operation of the solvent cleaning operation and the carbon adsorption system, and the information shall be maintained at the facility for a period of five years:
- (i) A log or record of the operating time for the carbon adsorption system, monitoring equipment, and the associated solvent cleaning operation.
 - (ii) For a carbon adsorption system that employs a continuous emission monitoring and recording system to measure and record the concentration of organic compounds in the exhaust gases, all three-hour periods of operation during which the average concentration level or reading in the exhaust gases is more than twenty per cent greater than the exhaust gas organic compound concentration level or reading measured by the most recent performance test that demonstrated that the solvent cleaning operation was in compliance.
 - (iii) For a carbon adsorption system that employs monitoring and recording equipment to measure and record the total mass steam flow rate for each regeneration cycle of each carbon bed, all carbon bed regeneration cycles during which the total mass steam flow rate was more than ten per cent below the total mass steam flow rate during the most recent performance test that demonstrated that the solvent cleaning operation was in compliance.
 - (iv) For a carbon adsorption system that employs monitoring and recording equipment to measure and record the temperature of each carbon bed after regeneration (and after completion of any cooling cycle), all carbon bed regeneration cycles during which the temperature of the carbon bed after regeneration (and after completion of any cooling cycle) was more than ten per cent greater than the carbon bed temperature during the most recent performance test that demonstrated that the solvent cleaning operation was in compliance.
- (4) Any owner or operator of a solvent cleaning operation that is exempt from the VOC-content limitation specified in paragraph (C)(1) of this rule, pursuant

to paragraph (D)(2)(e) or (D)(2)(m) of this rule, shall collect and record the following information each day for each such solvent cleaning operation and shall maintain the information at the facility for a period of five years:

- (a) The name and identification number of each solvent employed in the solvent cleaning operation.
 - (b) The volume, in gallons, of each solvent employed in the solvent cleaning operation.
 - (c) The total volume, in gallons, of all of the solvents employed in the solvent cleaning operation.
- (5) Any owner or operator of a solvent cleaning operation that is exempt from paragraphs (C)(1) and (C)(3) of this rule, pursuant to paragraph (D)(4) of this rule, shall collect and record the following information each day for each such solvent cleaning operation and shall maintain the information at the facility for a period of five years:
- (a) The name and identification number of each aerosol product employed in the solvent cleaning operation.
 - (b) The volume, in gallons, of each aerosol product employed in the solvent cleaning operation.
 - (c) The total volume, in gallons, of all of the aerosol products employed in the solvent cleaning operation.
- (6) Any owner or operator of a solvent cleaning operation that is exempt from the VOC-content limitation specified in paragraph (C)(1) of this rule, pursuant to paragraph (D)(2)(i) of this rule, shall record each day the total volume of ethyl acetate employed in such solvent cleaning operation and shall maintain the information at the facility for a period of five years.
- (7) Any manufacturer of coatings, inks, or adhesives that complies with paragraph (C)(6)(b)(i)(d) of this rule, shall record the following information each month for each cleaning material and shall maintain the information at the facility for a period of five years:
- (a) The total volume of fresh cleaning solvent material used for equipment cleaning.
 - (b) The total volume of cleaning solvent material recovered for either on-site or off-site recycling.

- (8) For an owner or operator that elects to monitor the temperature of the dryer exhaust gases immediately before the catalyst bed of the catalytic incinerator only, an inspection and maintenance plan shall be developed, maintained on-site, and made readily available upon the request of the appropriate Ohio EPA district office or local air agency. At a minimum, the plan shall include the following:
- (a) Annual sampling and analysis of the catalyst activity (i.e., conversion efficiency) following the manufacturer's or catalyst supplier's recommended procedures.
 - (b) Monthly inspection of the oxidizer system including the burner assembly and fuel supply lines for problems.
 - (c) Annual internal and monthly external visual inspection of the catalyst bed to check for channeling, abrasion, and settling. If problems are found, corrective action consistent with the manufacturer's recommendations shall be implemented and a new performance test to determine destruction efficiency in accordance with paragraph (C) of rule 3745-21-10 of the Administrative Code shall be conducted.
 - (d) Records, and a description of the results of each inspection and catalyst activity analysis.
- (H) Reporting of the monitoring and recordkeeping information.
- (1) Any owner or operator of a solvent cleaning operation that is subject to one or more of the VOC-content limitations specified in paragraph (C)(1) of this rule shall notify the director of any record maintained in accordance with paragraph (G)(1) of this rule showing the use of noncomplying solvents. A copy of such record shall be sent to the director within thirty days following the end of the month in which the use of noncomplying solvents occurs.
 - (2) Any owner or operator of a solvent cleaning operation that employs control equipment and is subject to paragraph (C)(5) of this rule shall submit to the director quarterly summaries of the records required by paragraphs (G)(2)(b) and (G)(3)(b) of this rule. These quarterly reports shall be submitted no later than April thirtieth, July thirty-first, October thirty-first, and January thirty-first, and shall cover the records for the previous calendar quarters.
 - (3) Any owner or operator of a solvent cleaning operation that is exempt from the VOC-content limitation specified in paragraph (C)(1) of this rule, pursuant to paragraph (D)(2)(e) or (D)(2)(m) of this rule, shall notify the director of any record maintained in accordance with paragraph (G)(4) of this rule showing

that the solvent cleaning operation employs more than the applicable maximum daily solvent usage limit. A copy of such record shall be sent to the director within thirty days following the end of the month in which the exceedance occurs.

- (4) Any owner or operator of a solvent cleaning operation that is exempt from paragraphs (C)(1) and (C)(3) of this rule, pursuant to paragraph (D)(4) of this rule, shall notify the director of any record maintained in accordance with paragraph (G)(5) of this rule showing that the solvent cleaning operation employs more than the maximum daily usage limit for aerosol products. A copy of such record shall be sent to the director within thirty days following the end of the month in which the exceedance occurs.
- (5) Any owner or operator of a solvent cleaning operation that is exempt from the VOC-content limitation specified in paragraph (C)(1) of this rule, pursuant to paragraph (D)(2)(i) of this rule, shall notify the director of any record maintained in accordance with paragraph (G)(6) of this rule showing that the solvent cleaning operation employs more than the maximum daily usage limit for ethyl acetate. A copy of such record shall be sent to the director within thirty days following the end of the month in which the exceedance occurs.

(I) Applicability notification, compliance certification, and permit application.

- (1) The owner or operator of a facility that is subject to this rule, is located in located in Ashtabula, Cuyahoga, Geauga, Lake, Lorain, Medina, Portage, or Summit county, and has an initial startup of solvent cleaning operations before April 2, 2009 shall notify the appropriate Ohio EPA district office or local air agency in writing that the solvent cleaning operation is subject to this rule not later than June 1, 2009, providing the information specified in paragraph (I)(5) of this rule.
- (2) The owner or operator of a facility that is subject to this rule, is located in Ashtabula, Cuyahoga, Geauga, Lake, Lorain, Medina, Portage, or Summit county, and has an initial startup of solvent cleaning operations on or after April 2, 2009 shall notify the appropriate Ohio EPA district office or local air agency in writing that the solvent cleaning operation is subject to this rule not later than either the date of initial startup of the solvent cleaning operation or June 1, 2009 (whichever is later), providing the information specified in paragraph (I)(5) of this rule. The application for a permit-to-install under rule 3745-31-02 of the Administrative Code may be used to fulfill the notification requirements of this paragraph.

- (3) The owner or operator of a facility that is subject to this rule, is located in Butler, Clermont, Hamilton or Warren county, and has an initial startup of solvent cleaning operations before the effective date of this rule shall notify the appropriate Ohio EPA district office or local air agency in writing that the solvent cleaning operation is subject to this rule not later than sixty days after the effective date of this rule, providing the information specified in paragraph (I)(5) of this rule.
- (4) The owner or operator of a facility that is subject to this rule, is located in Butler, Clermont, Hamilton or Warren county, and has an initial startup of solvent cleaning operations on or after the effective date of this rule shall notify the appropriate Ohio EPA district office or local air agency in writing that the solvent cleaning operation is subject to this rule not later than either the date of initial startup of the solvent cleaning operation or sixty days after the effective date of this rule (whichever is later), providing the information specified in paragraph (I)(5) of this rule. The application for a permit-to-install under rule 3745-31-02 of the Administrative Code may be used to fulfill the notification requirements of this paragraph.
- (5) The notification required in paragraphs (I)(1) to (I)(4) of this rule shall provide the following information:
- (a) Name and address of the owner or operator
 - (b) Address (i.e., physical location) of the affected facility.
 - (c) Description of the solvent cleaning operation and Ohio EPA emissions unit number, if assigned.
 - (d) Identification of the VOC emission requirement, the means of compliance and the compliance date for the solvent cleaning operation.
 - (e) An application for an operating permit or an application for a modification to an operating permit in accordance with Chapter 3745-77 of the Administrative Code (for sources subject to the Title V permit program) or an application for a permit-to-install and operate or an application for a modification to a permit-to-install and operate in accordance with Chapter 3745-31 of the Administrative Code (for sources not subject to the Title V permit program) for each subject process that meets one of the following:
 - (i) The process does not possess an effective operating permit or permit-to-install and operate.

(ii) The process possesses an effective operating permit or permit-to-install and operate and the owner or operator cannot certify in writing to the director that such subject process is in compliance with this rule. An application for an operating permit or permit-to-install and operate is not required provided the subject process is operating under an effective permit and certifies compliance. Such certification shall include all compliance certification requirements under paragraph (I)(6) of this rule.

~~(1) The owner or operator of a facility that is subject to this rule and that has a solvent cleaning operation with an initial startup date before April 2, 2009 shall notify the Ohio EPA district office or local air agency in writing that the solvent cleaning operation is subject to this rule. The notification, which shall be submitted not later than June 1, 2009 (or within sixty days after the solvent cleaning operation becomes subject to this rule), shall provide the following information:~~

~~(a) Name and address of the owner or operator.~~

~~(b) Address (i.e., physical location) of the affected facility.~~

~~(c) Description of the solvent cleaning operation and Ohio EPA emissions unit number, if assigned.~~

~~(d) Identification of the VOC emission requirement, the means of compliance and the compliance date for the solvent cleaning operation.~~

~~(e) An application for an operating permit or an application for a modification to an operating permit in accordance with Chapter 3745-77 of the Administrative Code (for sources subject to the Title V permit program) or an application for a permit-to-install and operate or an application for a modification to a permit-to-install and operate in accordance with Chapter 3745-31 of the Administrative Code (for sources not subject to the Title V permit program) for each subject process that meets one of the following:~~

~~(i) The process does not possess an effective operating permit or permit-to-install and operate.~~

~~(ii) The process possesses an effective operating permit or permit-to-install and operate and the owner or operator cannot certify in writing to the director that such subject process is in compliance with this rule. An application for an operating permit or permit-to-~~

~~install and operate is not required provided the subject process is operating under an effective permit and certifies compliance. Such certification shall include all compliance certification requirements under paragraph (I)(3) of this rule.~~

~~(2) The owner or operator of a facility that is subject to this rule and that has a solvent cleaning operation with an initial startup date on or after April 2, 2009 of this rule shall notify the Ohio EPA district office or local air agency in writing that the solvent cleaning operation is subject to this rule. The notification, which shall be submitted not later than either the date of initial startup of the solvent cleaning operation or June 1, 2009, whichever is later, and shall provide the information listed under paragraph (I)(1) of this rule. The application for an installation permit under rule 3745-31-02 of the Administrative Code may be used to fulfill the notification requirements of this paragraph.~~

~~(3)~~(6) Compliance certification.

(a) The owner or operator of a facility that is subject to this rule shall notify the Ohio EPA district office or local air agency in writing within thirty days following the completion of any of the following:

(i) For a solvent cleaning operation subject to the VOC emission requirements in paragraphs (C)(1) to (C)(4) of this rule, the first documented achievement of compliance with the requirements.

(ii) For a solvent cleaning operation subject to the VOC emission control requirement in paragraph (C)(5) of this rule, the following:

(a) The completion of installation and initial use of a VOC emission control system for the solvent cleaning operation.

(b) The completion of installation and initial use of any monitoring devices required under paragraph (G) of this rule for the solvent cleaning operation.

(c) The completion of any compliance testing conducted in accordance with paragraph (E) of this rule to demonstrate compliance with the applicable control requirement.

(b) The compliance certification under paragraph (I)~~(36)~~(6)(a) of this rule shall provide the following, where applicable:

(i) A description of the requirements.

- (ii) A description of the VOC emission control system.
- (iii) A description of the monitoring devices.
- (iv) A description of the records that document continuing compliance.
- (v) The results of any compliance tests, including documentation of test data.
- (vi) The results of any records that document continuing compliance, including calculations.
- (vii) A statement by the owner or operator of the affected facility as to whether the solvent cleaning operation has complied with the requirements.

(J) Requirements for an owner or operator of an industrial solvent cleaning facility that determines the facility is not subject to paragraphs (B) to (I) of this rule.

(1) The owner or operator of an industrial solvent cleaning facility that determines the total actual VOC emissions, before the application of air pollution control systems, from all industrial solvent cleaning processes at the facility are not equal to or greater than the limitation specified in paragraph (A)(1)(c) of this rule, and, therefore, the facility is not subject to the requirements in paragraphs (B) to (I) of this rule, shall select one of the following methods and maintain the following records for a period of five years. Records should not include those cleaning operations exempt pursuant to paragraphs (A)(2), (D)(1) and (D)(2) of this rule.

(a) Monthly recordkeeping method, the following:

- (i) Total pounds or gallons of each industrial cleaning solvent used per calendar month.
- (ii) VOC content (per cent by weight or pounds per gallon, whichever is consistent with the records kept in paragraph (J)(1)(a)(i) of this rule) of each industrial cleaning solvent used per calendar month.
- (iii) The total monthly VOC emissions, before the application of capture systems and control devices, in pounds for all industrial cleaning solvent employed per calendar month.
- (iv) The rolling twelve-month summation of VOC emissions, in tons, before the application of control systems and devices. The rolling

twelve-month summation shall be calculated as the total VOC emissions for the current calendar month, plus the total VOC emissions from the previous eleven calendar months.

(b) Daily emissions method.

Provided total VOC emissions are always less than 15.0 pounds per day, the owner or operator may elect to maintain the following records in lieu of the records required under paragraph (J)(1)(a) of this rule:

- (i) Total pounds or gallons of each industrial cleaning solvent used per day.
- (ii) VOC content (per cent by weight or pounds per gallon, whichever is consistent with the records kept in paragraph (J)(1)(b)(i) of this rule) of each industrial cleaning solvent used per day.
- (iii) The total daily VOC emissions, before the application of capture systems and control devices, in pounds for all industrial cleaning solvent employed per day.

Effective: 3/27/2022
Five Year Review (FYR) Dates: 11/29/2021 and 11/29/2026

CERTIFIED ELECTRONICALLY

Certification

03/17/2022

Date

Promulgated Under: 119.03
Statutory Authority: 3704.03(E)
Rule Amplifies: 3704.03(A), 3704.03(E)
Prior Effective Dates: 04/02/2009, 05/12/2011, 10/15/2015

3745-21-24

Flat wood paneling coatings.

[Comment: For dates and availability of non-regulatory government publications, publications of recognized organizations and associations, federal rules, and federal statutory provisions referenced in this rule, see paragraph (JJ) of rule 3745-21-01 of the Administrative Code titled "referenced materials."]

(A) Applicability.

This rule shall apply to any facility that meets both of the following criteria:

- (1) The facility is located in Ashtabula, Butler, Clermont, Cuyahoga, Geauga, Hamilton, Lake, Lorain, Medina, Portage, ~~or~~ Summit, or Warren county.
- (2) The facility has total actual VOC emissions from all flat wood paneling coating lines that are equal to or greater than 15.0 pounds of VOC emissions per day, before the application of capture and control devices.

(B) Definitions.

The definitions applicable to this rule are contained in paragraphs (A), (B), and (FF) of rule 3745-21-01 of the Administrative Code.

(C) VOC emission control requirements.**(1) VOC content limitations.**

The owner or operator of a facility that is subject to this rule shall not apply any flat wood paneling coating that exceeds the VOC content limitations specified in the following table:

Table - VOC content limitations

Categories	VOC Limitations (pounds per gallon, excluding water and exempt solvents)	VOC Limitations (pounds per gallon of solids)
Printed interior panels made of hardwood, plywood, or thin particleboard.	2.1	2.9
Natural finish hardwood plywood panels.	2.1	2.9

Class 2 finishes on hardboard panels.	2.1	2.9
Tileboard.	2.1	2.9
Exterior siding.	2.1	2.9

(2) As an alternative to the VOC emission limitations specified in the table of this rule, the owner or operator of a facility may choose to vent all VOC emissions to a control device with a minimum overall control efficiency of ninety per cent, by weight.

(3) Except as otherwise provided by this rule, compliance with the limitations specified in paragraph (C)(1) of this rule is based upon a weighted average by volume of all coating materials employed in the coating line in any one day. The VOC contents and densities of the coating materials subject to paragraph (C)(1) of this rule shall be determined in accordance with paragraph (B) of rule 3745-21-10 of the Administrative Code. The VOC emission rate, capture efficiency and control efficiency for coating lines subject to paragraph (C) of this rule shall be determined in accordance with paragraph (C) of rule 3745-21-10 of the Administrative Code. The averaging of VOC emissions over two or more coating lines in order to demonstrate compliance with an applicable emission limitation (i.e., cross-line averaging) is prohibited except as otherwise provided in this rule.

(D) Application equipment.

The owner or operator of a facility shall not apply coatings to wood products subject to the provisions of this rule unless the coating is applied with properly operating equipment, in accordance with proper operating procedures, and by the use of one of the following methods:

- (1) Electrostatic application.
- (2) High volume, low pressure (HVLP) spray.
- (3) Hand roller.
- (4) Flow coat.
- (5) Roll coater.
- (6) Dip coat.

(7) Paint brush.

(8) Detailing or touch-up guns.

(E) Work practice standards.

The owner or operator of a facility using VOC-containing materials in any flat wood paneling coating line shall ensure that VOC emissions are minimized by incorporating the following procedures:

- (1) Store all VOC coatings, thinners, and cleaning materials in closed containers.
- (2) Minimize spills of VOC containing coatings and thinners, and cleanup any spills immediately.
- (3) Convey any coating, thinners, and cleaning materials in closed containers or pipes.
- (4) Keep mixing vessels that contain VOC coatings or other materials closed except when specifically in use.
- (5) Minimize emissions of VOC during cleaning of storage, mixing and conveying equipment.

(F) Recordkeeping and reporting.

- (1) Any owner or operator of a flat wood paneling coating line which is exempt from the emission limitations specified in paragraph (C) of this rule because the combined VOC emissions from all flat wood paneling coating lines at the facility are less than 15.0 pounds of VOC per day (before add-on controls) shall collect and record the information each day and maintain the following information at the facility for a period of three years:
 - (a) The name and identification number of each coating, as applied.
 - (b) The mass of VOC per volume (including water and exempt solvents) and the volume of each coating (including water and exempt solvents), as applied, used each day.
 - (c) The total VOC emissions at the facility, as calculated using the following equation:

$$T = \sum_{i=1}^n A_i B_i$$

where:

T = Total VOC emissions from the combined flat wood paneling coating lines before the application of capture systems and control devices, in units of pounds per day.

n = Number of different coatings applied in the flat wood paneling coating lines at the facility.

i = Subscript denoting an individual coating.

A_i = Mass of VOC per volume of coating (i) (including water and exempt solvents), as applied, used at the facility, in units of pounds VOC per gallon.

B_i = Volume of coating (i) (including water and exempt solvents), as applied, used at the facility, in units of gallons per day. The instrument or method by which the owner or operator accurately measured or calculated the volume of each coating, as applied, shall also be described in the certification to the director.

- (2) Any owner or operator of a flat wood paneling coating line referenced in paragraph (F)(1) of this rule shall notify the director of any daily record showing that the combined VOC emissions from all such flat wood paneling coating lines at the facility are equal to or greater than 15.0 pounds of VOC per day (before add-on controls). A copy of such record shall be sent to the director within forty-five days after the exceedance occurs.

(3) Any owner or operator of a flat wood paneling coating line who elects to demonstrate the ongoing status of compliance with the applicable emission limitation by means of the use of complying coatings (i.e., each coating complies with the applicable emission limitation as applied) as specified in paragraph (C)(1) of this rule, shall collect and record the following information each month and maintain the information at the facility for a period of three years:

(a) The name and identification number of each coating, as applied.

(b) The mass of VOC per volume of each coating (excluding water and exempt solvents), as applied.

This information does not have to be kept on a line-by-line basis. Also, if an owner or operator mixes complying coatings at a coating line, it is not necessary to record the VOC content of the resulting mixture.

(4) Any owner or operator of a flat wood paneling coating line referenced in paragraph (F)(3) of this rule shall notify the director of any monthly record showing the use of noncomplying coatings. A copy of such record shall be sent to the director within thirty days following the end of the calendar month.

(5) Any owner or operator of a flat wood paneling coating line who elects to demonstrate the ongoing status of compliance with the applicable emission limitation as specified in paragraph (C)(1) of this rule by means of a daily volume-weighted average VOC content shall collect and record the following information each day for the coating line and maintain the information at the facility for a period of three years:

(a) The name and identification number of each coating, as applied.

(b) The mass of VOC per volume (excluding water and exempt solvents) and the volume of each coating (excluding water and exempt solvents), as applied.

(c) The daily volume-weighted average VOC content of all coatings, as applied, calculated in accordance with the equation specified in paragraph (B)(9) of rule 3745-21-10 of the Administrative Code for $(C_{\text{voc},2})_A$.

(6) Any owner or operator of a flat wood paneling coating line referenced in paragraph (F)(5) of this rule shall notify the director of any daily record showing that the daily volume-weighted average VOC content exceeds the applicable emission

limitation. A copy of such record shall be sent to the director within forty-five days after the exceedance occurs.

- (7) Any owner or operator of a flat wood paneling coating line who elects to demonstrate the ongoing status of compliance with the applicable pounds of VOC per gallon of solids limitation by means of control equipment shall collect and record the following information each day for the flat wood paneling coating line and maintain the information at the facility for a period of three years:
- (a) The name and identification number of each coating used.
 - (b) The mass of VOC per unit volume of coating solids, as applied, the volume solids content, as applied, and the volume, as applied, of each coating.
 - (c) The maximum VOC content (mass of VOC per unit volume of coating solids, as applied) or the daily volume-weighted average VOC content (mass of VOC per unit volume of coating solids, as applied) of all the coatings.
 - (d) The calculated, controlled VOC emission rate, in mass of VOC per unit volume of coating solids, as applied. The controlled VOC emission rate shall be calculated using the following:
 - (i) Either the maximum VOC content or the daily volume-weighted VOC content recorded in accordance with paragraph (F)(7)(c) of this rule.
 - (ii) The overall control efficiency for the control equipment as determined during the most recent emission test that demonstrated that the source was in compliance.
 - (e) A log or record of operating time for the capture (collection) system, control device, monitoring equipment, and the associated coating line.
 - (f) For thermal incinerators, all three-hour periods of operation during which the average combustion temperature was more than fifty degrees Fahrenheit below the average combustion temperature during the most recent performance test that demonstrated that the source was in compliance.
 - (g) For catalytic incinerators, all three-hour periods of operation during which the average temperature of the process vent stream immediately before the catalyst bed is more than fifty degrees Fahrenheit below the average temperature of the process vent stream during the most recent

performance test that demonstrated that the source was in compliance, and one of the following:

- (i) All three-hour periods of operation during which the average temperature difference across the catalyst bed is less than eighty per cent of the average temperature differences during the most recent performance test that demonstrated that the source was in compliance.
- (ii) Records required by an inspection and maintenance plan for the catalytic incinerator that meets paragraph (H)(2)(b)(iv) of this rule.

(h) For regenerative carbon adsorbers, the following:

- (i) All periods of the carbon bed regeneration cycle during which the total desorbing gas mass flow recorded during the regeneration cycle was less than the minimum value established during the most recent performance test that demonstrated that the source was in compliance.
- (ii) All periods of the carbon bed regeneration cycle when the carbon bed temperature recorded after the cooling cycle exceeded the maximum value established during the most recent performance test that demonstrated that the source was in compliance.

(i) For control devices that include a concentrator, the following:

- (i) All three-hour periods of operation during which the average desorption concentrate stream gas temperature was below the average desorption concentrate stream gas temperature during the most recent performance test that demonstrated that the source was in compliance.
- (ii) All three-hour periods of operation during which the average pressure drop of the dilute stream across the concentrator was below the average pressure drop of the dilute stream across the concentrator during the most recent performance test that demonstrated that the source was in compliance.

(j) For a capture system that is a permanent total enclosure, one of the following:

- (i) All three-hour periods of operation during which the average pressure drop across the enclosure was below 0.007 inch of water.

- (ii) All three-hour periods of operation during which the average facial velocity of air through all natural draft openings was below two hundred feet per minute.
- (k) For a capture system that is not a permanent total enclosure, one of the following:
 - (i) All three-hour periods of operation during which the average duct static pressure was below the average duct static pressure during the most recent performance test that demonstrated that the source was in compliance.
 - (ii) All three-hour periods of operation during which the average gas volumetric flow rate was below the average gas volumetric flow rate during the most recent performance test that demonstrated that the source was in compliance.
- (8) Any owner or operator of a flat wood paneling coating line referenced in paragraph (F)(7) of this rule shall notify the director of any daily record showing that the calculated, controlled VOC emission rate exceeds the applicable pounds of VOC per gallon of solids limitation. A copy of such record shall be sent to the director within forty-five days after the exceedance occurs.
- (9) Any owner or operator of a flat wood paneling coating line who elects to demonstrate the ongoing status of compliance with the applicable capture and control efficiency requirements or overall control efficiency requirements contained in paragraph (C)(2) of this rule shall collect and record the following information each day for the control equipment and maintain the information at the facility for a period of three years:
 - (a) A log or record of operating time for the capture (collection) system, control device, monitoring equipment, and the associated coating line.
 - (b) For thermal incinerators, all three-hour periods of operation during which the average combustion temperature was more than fifty degrees Fahrenheit below the average combustion temperature during the most recent performance test that demonstrated that the source was in compliance.
 - (c) For catalytic incinerators, all three-hour periods of operation during which the average temperature of the process vent stream immediately before the catalyst bed is more than fifty degrees Fahrenheit below the average temperature of the process vent stream during the most recent

performance test that demonstrated that the source was in compliance, and one of the following:

- (i) All three-hour periods of operation during which the average temperature difference across the catalyst bed is less than eighty per cent of the average temperature differences during the most recent performance test that demonstrated that the source was in compliance.
- (ii) Records required by an inspection and maintenance plan for the catalytic incinerator that meets paragraph (H)(2)(b)(iv) of this rule.

(d) For regenerative carbon adsorbers, the following:

- (i) All periods of the carbon bed regeneration cycle during which the total desorbing gas mass flow recorded during the regeneration cycle was less than the minimum value established during the most recent performance test that demonstrated that the source was in compliance.
- (ii) All periods of the carbon bed regeneration cycle when the carbon bed temperature recorded after the cooling cycle exceeded the maximum value established during the most recent performance test that demonstrated that the source was in compliance.

(e) For control devices that include a concentrator, the following:

- (i) All three-hour periods of operation during which the average desorption concentrate stream gas temperature was below the average desorption concentrate stream gas temperature during the most recent performance test that demonstrated that the source was in compliance.
- (ii) All three-hour periods of operation during which the average pressure drop of the dilute stream across the concentrator was below the average pressure drop of the dilute stream across the concentrator during the most recent performance test that demonstrated that the source was in compliance.

(f) For a capture system that is a permanent total enclosure, one of the following:

- (i) All three-hour periods of operation during which the average pressure drop across the enclosure was below 0.007 inch of water.

- (ii) All three-hour periods of operation during which the average facial velocity of air through all natural draft openings was below two hundred feet per minute.
- (g) For a capture system that is not a permanent total enclosure, one of the following:
 - (i) All three-hour periods of operation during which the average duct static pressure was below the average duct static pressure during the most recent performance test that demonstrated that the source was in compliance.
 - (ii) All three-hour periods of operation during which the average gas volumetric flow rate was below the average gas volumetric flow rate during the most recent performance test that demonstrated that the source was in compliance.
- (10) Any owner or operator of a flat wood paneling coating line referenced in paragraphs (F)(7) and (F)(9) of this rule shall submit to the director quarterly summaries of the records required by paragraphs (F)(7)(e) to (F)(7)(k) and (F)(9)(a) to (F)(9)(g) of this rule. These quarterly reports shall be submitted by April thirtieth, July thirty-first, October thirty-first, and January thirty-first, and shall cover the records for the previous calendar quarters.
- (11) Any owner or operator of a flat wood paneling coating line referenced in paragraphs (F)(7) and (F)(9) of this rule shall install and operate continuous monitoring and recording devices (i.e., for temperature or VOC concentration) and, if necessary, perform emission tests for the coating line to enable the recordkeeping required by paragraphs (F)(7)(f) to (F)(7)(k) and (F)(9)(b) to (F)(9)(g) of this rule. The continuous monitoring and recording devices shall be installed and placed in operation either by April 2, 2010 for any flat wood paneling coating line for which installation commenced before April 2, 2009 or by the initial startup of any new control equipment installed for the flat wood paneling coating line to achieve compliance with the VOC control requirements of this rule for any flat wood paneling coating line for which installation commenced on or after April 2, 2009. The continuous monitoring and recording devices shall be capable of accurately measuring the desired parameter, and the owner or operator shall properly operate and maintain the devices in accordance with the manufacturer's recommendations.

(G) Compliance test methods for coatings.

- (1) The VOC content and solids content of a coating shall be determined by the owner or operator in accordance with paragraph (B) of rule 3745-21-10 of the Administrative Code, wherein formulation data or USEPA method 24 procedures (which include various ASTM measurement methods) may be employed.
 - (2) The VOC content, in pounds VOC per gallon of coating, excluding water and exempt solvents, shall be calculated in accordance with the equation specified in paragraph (B)(8) of rule 3745-21-10 of the Administrative Code for $C_{\text{voc},2}$.
 - (3) The VOC content, in pounds VOC per gallon of solids, shall be calculated in accordance with the equation specified in paragraph (B)(8) of rule 3745-21-10 of the Administrative Code for $C_{\text{voc},3}$.
 - (4) The daily volume-weighted average VOC content of all coatings, as applied in pounds VOC per gallon of coating, shall be calculated in accordance with the equation specified in paragraph (B)(9) of rule 3745-21-10 of the Administrative Code for $(C_{\text{voc},2})_A$.
 - (5) The daily volume-weighted average VOC content of all coatings, as applied in pounds VOC per gallon of solids, shall be calculated in accordance with the equation specified in paragraph (B)(9) of rule 3745-21-10 of the Administrative Code for $C_{\text{voc},3}$.
- (H) Compliance tests for VOC emission control systems.
- (1) For a VOC emission control system used to comply with paragraph (C)(2) of this rule, the owner or operator shall conduct a compliance test to determine the capture efficiency of the capture system, the control efficiency of the control device (or each control device if a combination of control devices is employed), and the overall control efficiency of the VOC emission control system in accordance with paragraph (C) of rule 3745-21-10 of the Administrative Code wherein USEPA method 25 or 25A shall be used for determining the concentration of VOC in a gas stream.
 - (2) During the compliance test described in paragraph (H)(1) of this rule that demonstrates compliance, the owner or operator shall establish the operating limits (operating parameter values) for the monitoring devices as follows:
 - (a) If the control device is a thermal oxidizer, establish the operating limit as follows:

- (i) Monitor and record the combustion temperature either in the firebox of the thermal oxidizer or immediately downstream of the firebox before any substantial heat exchange occurs at least once every fifteen minutes during each of the three runs of the compliance test.
 - (ii) Calculate and record the average combustion temperature maintained during the compliance test. This average combustion temperature is the minimum operating limit for the thermal oxidizer.
- (b) If the control device is a catalytic oxidizer, establish the operating limits according to either paragraphs (H)(2)(b)(i) and (H)(2)(b)(ii) or paragraphs (H)(2)(b)(iii) and (H)(2)(b)(iv) of this rule.
- (i) Monitor and record the temperature just before the catalyst bed and the temperature difference across the catalyst bed at least once every fifteen minutes during each of the three test runs comprising a compliance test.
 - (ii) Calculate and record the average temperature just before the catalyst bed and the average temperature difference across the catalyst bed maintained during the compliance test. These are the minimum operating limits for the catalytic oxidizer.
 - (iii) Monitor and record the temperature just before the catalyst bed at least once every fifteen minutes during each of the three test runs of the compliance test. Use this recorded temperature data to calculate and record the average temperature before the catalyst bed during the performance test. This is the minimum operating limit for the catalytic oxidizer.
 - (iv) An inspection and maintenance plan shall be developed, maintained on-site, and made readily available upon the request of the appropriate Ohio EPA district office or local air agency. The plan shall include, at a minimum, the following:
 - (a) Annual sampling and analysis of the catalyst activity (i.e., conversion efficiency) following the manufacturer's or catalyst supplier's recommended procedures.
 - (b) Monthly inspection of the oxidizer system including the burner assembly and fuel supply lines for problems.
 - (c) Annual internal and monthly external visual inspection of the catalyst bed to check for channeling, abrasion, and settling.

If problems are found, corrective action consistent with the manufacturer's recommendations shall be implemented and a new performance test to determine destruction efficiency in accordance with paragraph (C) of this rule shall be conducted.

- (d) Records, and a description of the results of each inspection and catalyst activity analysis.
- (c) If the control device is a regenerative carbon adsorber, establish the operating limits as follows:
- (i) Monitor and record the total regeneration desorbing gas (e.g., steam or nitrogen) mass flow for each regeneration cycle, and the carbon bed temperature after each carbon bed regeneration and cooling cycle for the regeneration cycle either immediately preceding or immediately following the compliance test.
 - (ii) The operating limits for the regenerative carbon adsorber are the minimum total desorbing gas mass flow recorded during the regeneration cycle and the maximum carbon bed temperature recorded after the cooling cycle.
- (d) If the control device includes a concentrator, establish operating limits for the concentrator as follows:
- (i) Monitor and record the desorption concentrate stream gas temperature at least once every fifteen minutes during each of the three runs of the compliance test.
 - (ii) Use the data collected during the compliance test to calculate and record the average temperature. This is the minimum operating limit for the desorption concentrate gas stream temperature.
 - (iii) Monitor and record the pressure drop of the dilute stream across the concentrator at least once every fifteen minutes during each of the three runs of the performance test.
 - (iv) Use the data collected during the compliance test to calculate and record the average pressure drop. This is the minimum operating limit for the pressure drop of the dilute stream across the concentrator.

- (e) If the capture system is a permanent total enclosure, the operating limit is either one of the following, based on the criteria of a permanent total enclosure:
 - (i) The pressure drop across the enclosure shall be at least 0.007 inch of water.
 - (ii) The average facial velocity of air through all natural draft openings shall be at least two hundred feet per minute.
- (f) If the capture system is a not a permanent total enclosure, establish an operating limit for each separate capture device in the capture system as follows:
 - (i) Monitor and record either the gas volumetric flow rate or the duct static pressure for each separate capture device in the emission capture system at least once every fifteen minutes during each of the three test runs of the compliance test for capture efficiency at a point in the duct between the capture device and the control device inlet.
 - (ii) Calculate and record the average gas volumetric flow rate or average duct static pressure for the three test runs for each capture device. This average gas volumetric flow rate or average duct static pressure is the minimum operating limit for that specific capture device.

(I) Compliance dates.

- (1) The owner or operator of a facility that is subject to this rule shall comply with this rule no later than the following dates:
 - (a) For any flat wood paneling coating line located in Ashtabula, Cuyahoga, Geauga, Lake, Lorain, Medina, Portage, or Summit county for which installation commenced before April 2, 2009, the compliance date of the flat wood paneling coating line is April 2, 2010 or date of initial startup of the flat wood paneling coating line~~operation~~, whichever is later.
 - (b) For any flat wood paneling coating line located in Ashtabula, Cuyahoga, Geauga, Lake, Lorain, Medina, Portage, or Summit county for which installation commenced on or after April 2, 2009, the compliance date of the flat wood paneling coating line is the initial startup date of the flat wood paneling coating line.

(c) For any flat wood paneling coating line located in Butler, Clermont, Hamilton or Warren county for which installation commenced before the effective date of this rule, the compliance date is either March 1, 2023 or the date of initial startup of the flat wood paneling coating line, whichever is later.

(d) For any flat wood paneling coating line located in Butler, Clermont, Hamilton or Warren county for which installation commenced on or after the effective date of this rule, the compliance date is the date of initial startup of the flat wood paneling coating line.

(J) Applicability notification, compliance certification, and permit application.

(1) The owner or operator of a facility that is subject to this rule, is located in Ashtabula, Cuyahoga, Geauga, Lake, Lorain, Medina, Portage, or Summit county, and ~~that has an initial startup of a flat wood paneling coating line with an initial startup date~~ before April 2, 2009 shall notify the Ohio EPA district office or local air agency in writing that the flat wood panel coating line is subject to this rule. The notification, which shall be submitted not later than June 1, 2009 (or within sixty days after the flat wood paneling coating line becomes subject to this rule), shall provide the information specified in paragraph ~~(J)(3)~~(J)(5) of this rule.

(2) The owner or operator of a facility that is subject to this rule, is located in Ashtabula, Cuyahoga, Geauga, Lake, Lorain, Medina, Portage, or Summit county, and ~~that has an initial startup of a flat wood panel coating line with an initial startup date~~ on or after April 2, 2009 shall notify the Ohio EPA district office or local air agency in writing that the flat wood paneling coating line is subject to this rule. The notification, which shall be submitted not later than either the date of initial startup of the flat wood paneling coating line or by June 1, 2009, whichever is later, ~~and~~ shall provide the information listed under paragraph ~~(J)(3)~~(J)(5) of this rule. The application for an installation permit under rule 3745-31-02 of the Administrative Code may be used to fulfill the notification requirements of this paragraph.

(3) The owner or operator of a facility that is subject to this rule, is located in Butler, Clermont, Hamilton or Warren county, and has an initial startup of a flat wood paneling coating line before the effective date of this rule shall notify the appropriate Ohio EPA district office or local air agency in writing that the flat wood paneling coating line is subject to this rule not later than sixty days after the effective date of this rule, providing the information specified in paragraph (L)(5) of this rule.

(4) The owner or operator of a facility that is subject to this rule, is located in Butler, Clermont, Hamilton or Warren county, and has an initial startup of a flat wood paneling coating line on or after the effective date of this rule shall notify the appropriate Ohio EPA district office or local air agency in writing that the flat wood paneling coating line is subject to this rule not later than either the date of initial startup of the flat wood paneling coating line or sixty days after the effective date of this rule (whichever is later), providing the information specified in paragraph (L)(5) of this rule. The application for a permit-to-install under rule 3745-31-02 of the Administrative Code may be used to fulfill the notification requirements of this paragraph.

~~(3)~~(5) The notification required in paragraphs (J)(1) ~~and (J)(2)~~ to (J)(4) of this rule shall include the following information:

- (a) Name and address of the owner or operator.
- (b) Address (i.e., physical location) of the affected facility.
- (c) Equipment description and Ohio EPA emissions unit number (if assigned) of the flat wood paneling coating operation.
- (d) Identification of the VOC emission requirement, the means of compliance and the compliance date for the flat wood paneling coating operation.
- (e) An application for an operating permit or an application for a modification to an operating permit in accordance with Chapter 3745-77 of the Administrative Code (for sources subject to the Title V permit program) or an application for a permit-to-install and operate or an application for a modification to a permit-to-install and operate in accordance with Chapter 3745-31 of the Administrative Code (for sources not subject to the Title V permit program) for each subject process that meets one of the following:
 - (i) The process does not possess an effective operating permit or permit-to-install and operate.
 - (ii) The process possesses an effective operating permit or permit-to-install and operate and the owner or operator cannot certify in writing to the director that such subject process is in compliance with this rule. An application for an operating permit or permit-to-install and operate is not required provided the subject process is operating under an effective permit and certifies compliance. Such

certification shall include all compliance certification requirements under paragraphs (F) to (H) of this rule.

- (K) Requirements for an owner or operator of a flat wood paneling coating line that determines they are not subject to paragraphs (B) to (J) of this rule.

When establishing that the facility's total actual VOC emissions from all of the flat wood paneling coating lines (before the application of capture systems and control devices) are less than 15.0 pounds of VOCs per day, the owner or operator shall maintain the following daily records:

- (1) The total gallons of each flat wood paneling coating employed.
- (2) The VOC content of each flat wood paneling coating employed.
- (3) The total daily VOC emissions (summation of gallons x VOC content (in pounds per gallon) for all flat wood paneling coating employed).

Effective: 3/27/2022
Five Year Review (FYR) Dates: 11/29/2021 and 11/29/2026

CERTIFIED ELECTRONICALLY

Certification

03/17/2022

Date

Promulgated Under: 119.03
Statutory Authority: 3704.03(E)
Rule Amplifies: 3704.03(A), 3704.03(E)
Prior Effective Dates: 04/02/2009, 05/12/2011, 10/15/2015

3745-21-25

Control of VOC emissions from reinforced plastic composites production operations.

[Comment: For dates and availability of non-regulatory government publications, publications of recognized organizations and associations, federal rules, and federal statutory provisions referenced in this rule, see paragraph (JJ) of rule 3745-21-01 of the Administrative Code titled "referenced materials."]

(A) Applicability.

- (1) Except as otherwise provided in paragraph (A)(2) of this rule, this rule shall apply to any facility that has reinforced plastic composites production operations.
- (2) Excluded from this rule, except for the recordkeeping requirements specified under paragraphs (A)(2)(d) and (A)(2)(e) of this rule, are the following:
 - (a) Any facility that only repairs reinforced plastic composites. Repair includes the non-routine manufacture of individual components or parts intended to repair a larger item as defined in paragraph (GG) of rule 3745-21-01 of the Administrative Code.
 - (b) Any facility that is a research and development facility as defined under section 3704.01 of the Revised Code.
 - (c) The production of any reinforced plastic composite that is used in the manufacturing of fiberglass boats within the facility.
 - (d) Any facility in which the reinforced plastic composites operations not otherwise excluded under paragraphs (A)(2)(a) to (A)(2)(c) of this rule use less than 1.2 tons per year of thermoset resins and gel coats that contain styrene combined. The owner or operator of such facility shall maintain records of the amount (in pounds) of thermoset resins and gel coats used each month that contain styrene. These records shall be retained by the owner or operator for a period of not less than five years and shall be made available to the director or any authorized representative of the director for review during normal business hours.
 - (e) Any facility that has a potential to emit for VOC of less than 10.0 tons per year for all reinforced plastic composites production operations combined. The owner or operator of such facility shall maintain an up-to-date record of the potential to emit for VOC from all reinforced plastic composites production operations, shall employ emission factors or emission estimates in the calculation of the potential to emit that meet paragraph (E) of this rule, shall maintain the records specified

in paragraph (P)(2) of this rule for any sheet molding compound manufacturing machine, and within fifteen days after the end of each month, and shall maintain a record of the VOC emissions from any SMC manufacturing machine for the recent month and the rolling twelve-month period. However, this exclusion is not available for any facility that has, or once had, a potential to emit for VOC equal to or greater than 10.0 tons per year for all reinforced plastic composites production operations combined on or after December 14, 2010.

- (3) Upon achieving compliance with this rule, the reinforced plastic composites production operations at the facility are not required to meet rule 3745-21-07 of the Administrative Code.

(B) Definitions.

The definitions applicable to this rule are contained in paragraphs (A), (B) and (GG) of rule 3745-21-01 of the Administrative Code.

(C) Affected operations.

- (1) Except as otherwise provided in paragraphs (C)(2) and (C)(3) of this rule, the affected operations consist of all parts of the reinforced plastic composites production facility engaged in the following operations:
 - (a) Open molding.
 - (b) Compression/injection molding.
 - (c) Centrifugal casting.
 - (d) Continuous lamination.
 - (e) Continuous casting.
 - (f) Polymer casting.
 - (g) Pultrusion.
 - (h) Sheet molding compound (SMC) manufacturing.
 - (i) Bulk molding compound (BMC) manufacturing.
 - (j) Mixing.
 - (k) Cleaning of equipment used in reinforced plastic composites manufacture.

- (l) VOC-containing materials storage.
 - (m) Repair operations on reinforced plastic composites parts that are manufactured at the facility.
- (2) The following operations and materials are specifically excluded from in this rule:
- (a) Application of mold sealing and release agents.
 - (b) Mold stripping and cleaning.
 - (c) Repair of reinforced plastic composites parts that the facility did not manufacture, including non-routine manufacturing of parts.
 - (d) Personal activities that are not part of the manufacturing operations (such as hobby shops on military bases).
 - (e) Prepreg materials.
 - (f) Non-gel coat surface coatings.
 - (g) Application of putties, polyputties, and adhesives.
 - (h) Repair or production materials that do not contain resin or gel coat.
 - (i) Research and development operations as defined under section 3704.01 of the Revised Code.
 - (j) Polymer casting.
 - (k) Any closed molding operation other than compression/injection molding (for example, resin transfer molding).

[Note: The exclusion of certain operations from this rule applies only to operations specifically listed in this paragraph. This rule still applies to any co-located operations. For example, although polymer casting and resin transfer molding operations are specifically excluded from this rule, any gel coating, mixing, VOC-containing materials storage, or cleaning operation associated with a polymer casting operation or a resin transfer molding operation is still subject to this rule.]

- (3) Production resins that shall meet military specifications are allowed to meet the monomer content limit contained in that specification. In order for this exemption to be used, the owner or operator shall supply to the appropriate Ohio EPA district office or local air agency the specifications certified as

accurate by the military procurement officer, and those specifications shall state a requirement for a specific resin, or a specific resin monomer content. Production resins for which this exemption is used shall be applied with nonatomizing resin application equipment unless the owner or operator can demonstrate this is infeasible. The owner or operator shall keep a record of the resins for which the owner or operator is using this exemption.

(D) VOC control.

- (1) The owner or operator of the reinforced plastic composites production facility shall meet the work practice standards in table 1 of this rule for affected operations.
- (2) If the reinforced plastic composites production facility has VOC emissions less than the threshold of one hundred tons of VOC per year from the combination of all open molding, centrifugal casting, continuous lamination/casting, pultrusion, SMC manufacturing, mixing, and BMC manufacturing, the owner or operator shall meet the VOC emissions limits in table 2 of this rule. A facility's VOC emissions threshold shall be calculated in accordance with paragraph (F) of this rule.
- (3) Except as provided in paragraph (D)(4) of this rule, if the reinforced plastic composites production facility has VOC emissions equal to or greater than the threshold of one hundred tons of VOC per year from the combination of all open molding, centrifugal casting, continuous lamination/casting, pultrusion, SMC manufacturing, mixing, and BMC manufacturing, the owner or operator shall reduce the total VOC emissions from these operations by at least ninety-five per cent by weight. As an alternative to meeting ninety-five per cent by weight, the owner or operator may meet the VOC emissions limits in table 3 of this rule. A facility's VOC emissions threshold shall be calculated in accordance with paragraph (F) of this rule.
- (4) If the reinforced plastic composites production facility manufactures large reinforced plastic composites parts using open molding or pultrusion operations, the specific open molding and pultrusion operations used to produce large parts are not required to reduce VOC emissions by ninety-five weight per cent, but shall meet the emission limits in table 2 of this rule. A large open molding part is defined as a part that, when the final finished part is enclosed in the smallest rectangular six-sided box into which the part can fit, the total interior volume of the box exceeds two hundred fifty cubic feet, or any interior sides of the box exceed fifty square feet. A large pultruded part is a part that exceeds an outside perimeter of twenty-four inches or has more than three hundred fifty reinforcements.

- (5) Once a reinforced plastic composites production facility equals or exceeds the one hundred tons of VOC per year threshold of paragraph (D)(3) of this rule on or after December 14, 2009, the facility is always subject to paragraph (D)(3) of this rule, except as otherwise provided in paragraph (D)(6) of this rule.
- (6) In the event a reinforced plastic composites production facility equals or exceeds the one hundred tons of VOC per year threshold of paragraph (D)(3) of this rule on or after December 14, 2009, but reduces emissions to less than the one hundred tons of VOC per year threshold by no later than the compliance date of this rule, the facility is not subject to paragraphs (D)(3) of this rule. If such reinforced plastic composites production facility subsequently equals or exceeds the one hundred tons of VOC per year threshold of paragraph (D)(3) of this rule, then the facility becomes subject to paragraph (D)(3) of this rule.
- (7) If the reinforced plastic composites production facility has repair operations subject to this rule, these repair operations shall meet table 1 and table 2 of this rule and are not required to meet the ninety-five per cent VOC emissions reduction requirement in paragraph (D)(3) of this rule.
- (8) Except where exempted under paragraph (D)(9) of this rule, any owner or operator of a SMC manufacturing machine shall install and operate a VOC emission control system that reduces the VOC emissions from the SMC manufacturing machine by at least ninety-five per cent by weight (i.e., an overall control efficiency of at least ninety-five per cent by weight).
- (9) Exempted from the requirement of paragraph (D)(8) of this rule is any uncontrolled SMC manufacturing machine with VOC emissions of less than 25.0 tons per rolling twelve-month period.
- (10) If an add-on control device is used to comply with this rule, such add-on control device shall meet 40 CFR part 63, subpart SS. The owner or operator shall also establish each control device operating limit in 40 CFR part 63, subpart SS, that applies.
- (11) Alternatives.

The provisions of paragraphs (D)(1) to (D)(10) of this rule shall not apply to any emissions unit that meets the following:

- (a) The director has determined that best available technology for the emissions unit, as required by rule 3745-31-05 of the Administrative Code, is a control requirement or emission limitation that is either less stringent than or inconsistent with paragraph (D) of this rule. Best available technology

shall be defined in accordance with division (F) of section 3704.01 of the Revised Code and, for purposes of this paragraph, shall provide, where an emission limitation is applicable, the lowest emission limitation that the emissions unit is capable of meeting by the application of control technology that is reasonably available considering technological and economic feasibility. Also, for an emissions unit located within an ozone nonattainment area, the best available technology determination shall comply with Section 193 (general savings clause) of the Clean Air Act.

- (b) The USEPA has informed the Ohio EPA, in writing, prior to the issuance of a final permit-to-install for the emissions unit, that the agency has no objection to the issuance of the final permit and the control requirement or emission limitation specified therein.
 - (c) A final permit-to-install has been issued for the emissions unit pursuant to Chapter 3745-31 of the Administrative Code. The permit-to-install shall contain terms and conditions that specify the control requirement or emission limitation that is the basis for the director's best available technology determination for the emissions unit, as described in paragraph (D)(11)(a) of this rule, and the permit-to-install shall be issued by the Ohio EPA in a manner that makes the control requirement or emission limitation federally enforceable.
 - (d) USEPA has approved the alternative limitation as a revision to the Ohio state implementation plan.
- (E) Procedures for determination of VOC emissions factors for reinforced plastic composites production operations and determination of monomer content of resins and gel coats.
- (1) Emissions factors are used in this rule to determine compliance with certain VOC emissions limits in table 2 and table 3 of this rule and to calculate VOC emissions. A person may use the equations in table 1 of 40 CFR part 63, subpart WWW to calculate such emissions factors or may use any VOC emissions factor approved by USEPA, such as emission factors or emission factor equations from AP-42. These equations and emissions factors are intended to provide a method for one to demonstrate compliance without the need to conduct a VOC emissions test. In lieu of these equations and emissions factors, the owner or operator can elect to use site-specific VOC emissions factors to demonstrate compliance and to calculate VOC emissions provided the site-specific VOC emissions factors are incorporated in the facility's air emissions permit and are based on actual facility VOC emissions test data using the test procedures in 40 CFR 63.5850 or paragraph (C) of rule 3745-21-10 of the

Administrative Code. Stack test data for the facility shall supersede emission factors and other emission estimating techniques.

(2) In order to determine the monomer content of resins and gel coats, the owner or operator may rely on information provided by the material manufacturer, such as manufacturer's formulation data and material safety data sheets (MSDS), using the procedures specified in paragraphs (E)(2)(a) to (E)(2)(c) of this rule, as applicable.

(a) Include in the total monomer content each monomer compound that is present at 0.1 per cent by mass or more for OSHA-defined carcinogens, as specified in paragraph A.6.4.1 of 29 CFR 1910.1200, appendix A and at 1.0 per cent by mass or more for other monomer compounds.

(b) If the monomer content is provided by the material supplier or manufacturer as a range, the owner or operator shall use the upper limit of the range for determining compliance. If a separate measurement of the total monomer content, such as an analysis of the material by USEPA method 311 of 40 CFR part 63, appendix A, exceeds the upper limit of the range of the total monomer content provided by the material supplier or manufacturer, then the owner or operator shall use the measured monomer content to determine compliance.

(c) If the monomer content is provided as a single value, the owner or operator may use that value to determine compliance. If a separate measurement of the total monomer content is made and is less than two percentage points higher than the value for total monomer content provided by the material supplier or manufacturer, then the owner or operator still may use the provided value to demonstrate compliance. If the measured total monomer content exceeds the provided value by two percentage points or more, then the owner or operator shall use the measured total monomer content to determine compliance.

(F) Calculation of facility's VOC emissions threshold.

(1) To calculate the facility's VOC emissions threshold in tons per year for purposes of determining which requirements apply under paragraph (D) of this rule, the owner or operator shall use the procedures in either paragraph (F)(2) of this rule for new facilities prior to startup, or paragraph (F)(3) of this rule for existing facilities and new facilities after startup. A facility's VOC emissions threshold pertains to the following operations: open molding, centrifugal casting, continuous lamination/casting, pultrusion, SMC manufacturing, mixing, and BMC manufacturing. The owner or operator is not required to calculate or

report emissions under this paragraph if the facility does not have any of those operations. However, emissions calculation and emission reporting procedures in other paragraphs of this rule still apply. For the facility's VOC emissions threshold, calculate VOC emissions prior to any add-on control device, and do not include VOC emissions from any resin or gel coat used in operations subject to the boat manufacturing NESHAP, 40 CFR part 63, subpart VVVV, or from the manufacture of large parts as defined in paragraph (D)(4) of this rule. A "new facility" means a facility that has one or more operations specified in paragraph (F)(1) of this rule in which all such operations have a startup on or after December 14, 2009. An "existing facility" means a facility that has one or more operations specified in paragraph (F)(1) of this rule in which and at least one such operation has a startup prior to December 14, 2009.

- (2) For new facilities prior to startup, the owner or operator shall calculate a weighted average VOC emissions factor for the operations specified in paragraph (F)(1) of this rule on a pounds of VOC per ton of resin, monomer, or gel coat basis. Base the weighted average on the projected operation for the twelve months subsequent to facility startup. Multiply the weighted average VOC emissions factor by projected resin, monomer, or gel coat use over the same period. The owner or operator may calculate a VOC emissions factor based on the factors in table 1 of 40 CFR part 63, subpart WWWW, or may use any VOC emissions factor approved by USEPA, such as factors from AP-42, or VOC emissions test data from similar facilities. The organic HAP emissions factors in table 1 of 40 CFR part 63, subpart WWWW are equivalent to the VOC emissions factors for this rule.
- (3) For existing facilities and new facilities after startup, the owner or operator may use the procedures in either paragraph (F)(3)(a), (F)(3)(b), or (F)(3)(c) of this rule for the operations specified in paragraph (F)(1) of this rule. If the emission factors for an existing facility have changed over the period of time prior to its initial compliance date due to incorporation of pollution-prevention control techniques, the existing facility may base the average emission factor on its operations as they exist on the compliance date. If an existing or new facility has accepted an enforceable permit limit that would result in less than one hundred tons per year (per rolling twelve-month period) of VOC measured prior to any add-on controls, and can demonstrate that it will operate at that level subsequent to the compliance date, it can be deemed to be below the one hundred tons per year threshold.
 - (a) Use a calculated emission factor.

Calculate a weighted average VOC emissions factor on a pounds per ton of resin, monomer, or gel coat basis. Base the weighted average on the

prior twelve months of operation. Multiply the weighted average VOC emissions factor by resin, monomer, or gel coat use over the same period. The owner or operator may calculate this VOC emissions factor based on the equations in table 1 of 40 CFR part 63, subpart WWWW, or the owner or operator may use any VOC emissions factor approved by USEPA, such as emission factors or emission factor equations from AP-42, or site-specific VOC emissions factors if they are supported by VOC emissions test data. The organic HAP emissions factors in table 1 of 40 CFR part 63, subpart WWWW are equivalent to the VOC emissions factors for this rule.

(b) Conduct performance testing.

Conduct performance testing using the test procedures in 40 CFR 63.5850 or paragraph (C) of rule 3745-21-10 of the Administrative Code to determine a site-specific VOC emissions factor in units of pounds of VOC per ton of resin, monomer, or gel coat used. Conduct the test under conditions expected to result in the highest possible VOC emissions. Multiply this factor by annual resin, monomer, or gel coat use to determine annual VOC emissions. This calculation shall be repeated and reported annually.

(c) Pultrusion operations.

For pultrusion operations employing enclosures or resin injection (direct or preform) pursuant to paragraph (I)(5)(b) of this rule, actual emissions may be calculated as four tenths and one tenth, respectively, of open line emissions, where open line emissions are calculated as specified in air permits covering these operations.

- (4) Existing facilities shall initially perform this calculation based on their twelve months of operation prior to December 14, 2009, and include this information with their applicability notification report. Existing facilities shall repeat the calculation based on their resin, monomer, and gel coat use in the twelve months prior to their compliance date, and submit this information with ~~their~~the initial compliance report.
- (5) After the initial compliance date, existing and new facilities shall calculate VOC emissions over the twelve-month period ending June thirtieth or December thirty-first, whichever date is the first date following the compliance date specified in paragraph (R) of this rule. Subsequent calculations should cover the periods in the semiannual compliance reports.

(G) Options for meeting the VOC emissions limits for open molding and centrifugal casting operations.

The owner or operator shall use one of the following methods in paragraphs (G)(1) to (G)(4) of this rule to meet the VOC emissions limits for open molding or centrifugal casting operations specified in table 2 or table 3 of this rule. The owner or operator may use any control method that reduces VOC emissions, including reducing resin and gel coat monomer content, changing to nonatomized mechanical application, using covered curing techniques, and routing part or all of the VOC emissions to an add-on control. The owner or operator may use different compliance options for the different operations listed in table 2 or table 3 of this rule. The necessary calculations shall be completed within thirty days after the end of each month. The owner or operator may switch between the compliance options in paragraphs (G)(1) to (G)(4) of this rule. When the owner or operator changes to an option based on a twelve-month rolling average, the owner or operator shall base the average on the previous twelve months of data calculated using the compliance option the owner or operator is changing to, unless the owner or operator was previously using an option that did not require the owner or operator to maintain records of resin and gel coat use. In this case, the owner or operator shall immediately begin collecting resin and gel coat use data and demonstrate compliance twelve months after changing options.

(1) Demonstrate that an individual resin or gel coat, as applied, meets the applicable emission limit in table 2 or table 3 of this rule.

- (a) Calculate the actual VOC emissions factor for each different process stream within each operation type. A process stream is defined as each individual combination of resin or gel coat, application technique, and control technique. Process streams within operations types are considered different from each other if any of the following four characteristics vary: the neat resin plus or neat gel coat plus monomer content, the gel coat type, the application technique, or the control technique. The owner or operator shall calculate VOC emissions factors for each different process stream by using the appropriate equations in table 1 of 40 CFR part 63, subpart WWWW for open molding and for centrifugal casting, or site-specific VOC emissions factors discussed in paragraph (E) of this rule. The emission factor calculation should include any and all emission reduction techniques used including any add-on controls. If vapor suppressants are used to reduce VOC emissions, the owner or operator shall determine the vapor suppressant effectiveness (VSE) by conducting testing according to the procedures specified in 40 CFR part 63, Subpart WWWW, appendix A. If an add-on control device is used to reduce VOC emissions, the owner or operator shall determine the add-on control factor by conducting capture and control efficiency testing

using the procedures specified in 40 CFR 63.5850. The VOC emissions factor calculated from the equations in table 1 of 40 CFR part 63, subpart WWWW, or a site-specific emissions factor, is multiplied by the add-on control factor to calculate the VOC emissions factor after control. The add-on control factor used in the VOC emissions factor equations is calculated from the following equation:

$$\text{Add-on Control Factor} = 1 - (\% \text{ Control Efficiency} / 100)$$

where:

Per cent control efficiency = value calculated from VOC emissions test measurements made according to 40 CFR 63.5850.

- (b) If the calculated emission factor is less than or equal to the appropriate emission limit, the owner or operator has demonstrated that this process stream complies with the emission limit in table 2 of this rule. It is not necessary that all process streams, considered individually, demonstrate compliance to use this option for some process streams. However, for any individual resin or gel coat being used, if any of the process streams that include that resin or gel coat are to be used in any averaging calculations described in paragraphs (G)(2) to (G)(4) of this rule, then all process streams using that individual resin or gel coat shall be included in the averaging calculations.
- (2) Demonstrate that, on average, the individual VOC emissions limits for each unique combination of operation type and resin application method or gel coat type shown in table 2 of this rule that applies to the facility are met.
- (a) Group the process streams described in paragraph (G)(1) of this rule by operation type and resin application method or gel coat type listed in table 2 of this rule and then calculate a weighted average emission factor based on the amounts of each individual resin or gel coat used for the last twelve months. To do this, sum the product of each individual VOC emissions factor calculated in paragraph (G)(1)(a) of this rule and the amount of neat resin plus and neat gel coat plus usage that corresponds to the individual factors and divide the numerator by the total amount of neat resin plus and neat gel coat plus used in that operation type as shown in the following equation:

$$\text{Average VOC emissions factor} = \frac{\sum_{i=1}^n (\text{Actual Process Stream } EF_i * \text{Material}_i)}{\sum_{i=1}^n \text{Material}_i}$$

where:

Actual Process Stream EF_i = actual VOC emissions factor for process stream i , pounds of VOC per ton of neat resin plus or neat gel coat plus.

Material_i = the amount of neat resin plus or neat gel coat plus used during the last twelve calendar months for process stream i , tons.

n = number of process streams where the owner or operator calculated a VOC emissions factor.

- (b) The owner or operator may, but is not required to, include process streams where the owner or operator has demonstrated compliance as described in paragraph (G)(1) of this rule, subject to the limitations described in paragraph (G)(1)(b) of this rule, and the owner or operator is not required to and should not include process streams for which the owner or operator will demonstrate compliance using the procedures in paragraph (G)(4) of this rule.
- (c) Compare each VOC emissions factor calculated in paragraph (G)(2)(a) of this rule with its corresponding VOC emissions limit in table 2 or table 3 of this rule. If all emissions factors are equal to or less than ~~their~~the corresponding emission limits, then the operation is in compliance.

(3) Demonstrate compliance with a weighted average VOC emissions limit.

Demonstrate each month that each weighted average of the VOC emissions limits in table 2 or table 3 of this rule that apply are being met. When using this option, the owner or operator shall demonstrate compliance with the weighted average VOC emissions limit for all open molding operations, and then separately demonstrate compliance with the weighted average VOC emissions limit for all centrifugal casting operations. Open molding operations and centrifugal casting operations may not be averaged with each other.

- (a) Each month calculate the weighted average VOC emissions limit for all open molding operations and the weighted average VOC emissions limit

for all centrifugal casting operations for the facility for the last twelve-month period to determine the VOC emissions limit the owner or operator shall meet. To do this, multiply the individual VOC emissions limits in table 2 or table 3 of this rule for each open molding (centrifugal casting) operation type by the amount of neat resin plus or neat gel coat plus used in the last twelve months for each open molding (centrifugal casting) operation type, sum these results, and then divide this sum by the total amount of neat resin plus and neat gel coat plus used in open molding (centrifugal casting) over the last twelve months as shown in the following equation:

$$\text{Weighted Average VOC Emissions Limit} = \frac{\sum_{i=1}^n (EL_i * \text{Material}_i)}{\sum_{i=1}^n \text{Material}_i}$$

where:

EL_i = VOC emissions limit for operation type i , pounds per ton from table 2 or table 3 of this rule.

Material_i = amount of neat resin plus or neat gel coat plus used during the last twelve-month period for operation type i , tons.

n = number of operations.

- (b) Each month calculate the weighted average VOC emissions factor for open molding and centrifugal casting. To do this, multiply the actual open molding (centrifugal casting) operation VOC emissions factors calculated in paragraph (G)(2)(a) of this rule and the amount of neat resin plus and neat gel coat plus used in each open molding (centrifugal casting) operation type, sum the results, and divide this sum by the total amount of neat resin plus and neat gel coat plus used in open molding (centrifugal casting) operations as shown in the following equation:

$$\text{Actual Weighted Average VOC Emissions Factor} = \frac{\sum_{i=1}^n (\text{Actual Operation EF}_i * \text{Material}_i)}{\sum_{i=1}^n \text{Material}_i}$$

where:

Actual Operation EF_i = Actual VOC emissions factor for operation type i, pounds of VOC per ton of neat resin plus or neat gel coat plus.

Material_i = amount of neat resin plus or neat gel coat plus used during the last twelve calendar months for operation type i, tons.

n = number of operations.

- (c) Compare the values calculated in paragraphs (G)(3)(a) and (G)(3)(b) of this rule. If each twelve-month rolling average VOC emissions factor is less than or equal to the corresponding twelve-month rolling average VOC emissions limit, then the operation is in compliance.
- (4) Meet the VOC emissions limit for one application method and use the same resins for all application methods of that resin type.

This option is limited to resins of the same type. The resin types for which this option may be used are noncorrosion-resistant, corrosion-resistant ~~and/or~~ high strength, and tooling.

- (a) For any combination of manual resin application, mechanical resin application, filament application, or centrifugal casting, the owner or operator may elect to meet the VOC emissions limit for any one of these application methods and use the same resin in all of the resin application methods listed in this paragraph. Table 4 of this rule presents the possible combinations based on the owner or operator selecting the application process that results in the highest allowable monomer content resin. If the resin's monomer content is below the applicable value shown in the table 4 of this rule, the resin is in compliance.
- (b) The owner or operator may also use a weighted average monomer content for each application method described in paragraph (G)(4)(a) of this rule. Calculate the weighted average monomer content monthly. Use the equation in paragraph (G)(2)(a) of this rule except substitute monomer content for VOC emissions factor. The operation is in compliance if the

weighted average monomer content based on the last twelve months of resin use is less than or equal to the applicable monomer contents in the table 4 of this rule.

(c) The owner or operator may simultaneously use the averaging provisions in paragraph (G)(2) or (G)(3) of this rule to demonstrate compliance for any operations or resins the owner or operator does not include in the compliance demonstrations in paragraphs (G)(4)(a) and (G)(4)(b) of this rule. However, any resins for which the owner or operator claims compliance under the option in paragraphs (G)(4)(a) and (G)(4)(b) of this rule shall not be included in any of the averaging calculations described in paragraph (G)(2) or (G)(3) of this rule.

(d) The owner or operator does not have to keep records of resin use for any of the individual resins where the owner or operator demonstrates compliance under the option in paragraph (G)(4)(a) of this rule unless the owner or operator elects to include that resin in the averaging calculations described in paragraph (G)(4)(b) of this rule.

(H) Options for meeting the VOC emissions limits for continuous lamination/casting operations.

For continuous casting/lamination operations, the owner or operator shall use one or more of the options listed in paragraphs (H)(1) to (H)(4) of this rule to meet the VOC emissions limits specified in table 2 or table 3 of this rule and shall use the calculation procedures provided in paragraphs (J) to (M) of this rule.

(1) Compliant line option.

Demonstrate that each continuous lamination line and each continuous casting line complies with the applicable VOC emissions limit.

(2) Averaging option.

Demonstrate that all continuous lamination and continuous casting lines combined, comply with the applicable VOC emissions limit.

(3) Add-on control device option.

If the operation shall meet the 58.5 weight per cent VOC emissions reduction limit in table 2 of this rule, the owner or operator has the option of demonstrating that the operation achieves ninety-five per cent reduction of all wet-out area VOC emissions.

(4) Combination option.

Use any combination of options in paragraphs (H)(1) to (H)(3) of this rule.

(I) Options for meeting the standards for pultrusion operations subject to the sixty per cent by weight VOC emissions reductions requirement.

For pultrusion operations, the owner or operator shall use one or more of the options in paragraphs (I)(1) to (I)(5) of this rule to meet the sixty weight per cent VOC emissions limit in table 2 of this rule.

- (1) Achieve an overall reduction in VOC emissions of sixty per cent by weight capturing the VOC emissions and venting them to a control device or any combination of control devices. Conduct capture and destruction efficiency testing as specified in 40 CFR 63.5850 to determine the per cent VOC emissions reduction.
- (2) Design, install, and operate wet area enclosures and resin drip collection systems on pultrusion machines that meet the following:
 - (a) The enclosure shall cover and enclose the open resin bath and the forming area in which reinforcements are pre-wet or wet-out and moving toward the die. The surfaces of the enclosure shall be closed except for openings to allow material to enter and exit the enclosure.
 - (b) For open bath pultrusion machines with a radio frequency pre-heat unit, the enclosure shall extend from the beginning of the resin bath to within 12.5 inches or less of the entrance of the radio frequency pre-heat unit. If the stock that is within 12.5 inches or less of the entrance to the radio frequency pre-heat unit has any drip, it shall be enclosed. The stock exiting the radio frequency pre-heat unit is not required to be in an enclosure if the stock has no drip between the exit of the radio frequency pre-heat unit to within 0.5 inches of the entrance of the die.
 - (c) For open bath pultrusion machines without a radio frequency pre-heat unit, the enclosure shall extend from the beginning of the resin bath to within 0.5 inches or less of the die entrance.
 - (d) For pultrusion lines with pre-wet area prior to direct die injection, no more than 12.5 inches of open wet stock is permitted between the entrance of the first pre-wet area and the entrance to the die. If the pre-wet stock has any drip, it shall be enclosed.

- (e) The total open area of the enclosure shall not exceed two times the cross sectional area of the puller window and shall comply with the following:
 - (i) All areas that are open need to be included in the total open area calculation with the exception of access panels, doors, or hatches that are part of the enclosure.
 - (ii) The area that is displaced by entering reinforcement or exiting product is considered open.
 - (iii) Areas that are covered by brush covers are considered closed.
 - (f) Open areas for level control devices, monitoring devices, agitation shafts, and fill hoses shall have no more than 1.0 inch clearance.
 - (g) The access panels, doors, or hatches that are part of the enclosure shall close tightly. Damaged access panels, doors, or hatches that do not close tightly shall be replaced.
 - (h) The enclosure may not be removed from the pultrusion line, and access panels, doors, or hatches that are part of the enclosure shall remain closed whenever resin is in the bath, except for the time period discussed in paragraph (I)(2)(i) of this rule.
 - (i) The maximum length of time the enclosure may be removed from the pultrusion line or the access panels, doors, or hatches and may be open, is thirty minutes per eight-hour shift, forty-five minutes per twelve-hour shift, or ninety minutes per day if the machine is operated for twenty-four hours in a day. The time restrictions do not apply if the open doors or panels do not cause the limit of two times the puller window area to be exceeded. Facilities may average the times that access panels, doors, or hatches are open across all operating lines. In that case the average shall not exceed the times shown in this paragraph. All lines included in the average shall have operated the entire time period being averaged.
 - (j) No fans, blowers, or air lines may be allowed within the enclosure. The enclosure shall not be ventilated.
- (3) Use direct die injection pultrusion machines with resin drip collection systems that meet the following:
- (a) All the resin that is applied to the reinforcement is delivered directly to the die.

- (b) No exposed resin is present, except at the face of the die.
 - (c) Resin drip is captured in a closed system and recycled back to the process.
- (4) Use a preform injection system that meets the definition in paragraph (GG) of rule 3745-21-01 of the Administrative Code.
- (5) Use any combination of options in paragraphs (I)(1) to (I)(4) of this rule in which different pultrusion lines comply with different options described in paragraphs (I)(1) to (I)(4) of this rule, in addition to one of the following:
- (a) Each individual pultrusion machine meets the sixty per cent reduction requirement.
 - (b) The weighted average reduction based on resin throughput of all pultrusion machines combined is sixty per cent. For purposes of the average per cent reduction calculation, wet area enclosures reduce VOC emissions by sixty per cent, and direct die injection and preform injection reduce VOC emissions by ninety per cent. For averaging purposes, zero reduction credit is earned during production on lines that have not installed and operated enclosures or injection systems as described in paragraphs (I)(2) to (I)(4) of this rule.
- (J) Calculation of annual uncontrolled and controlled VOC emissions from wet-out areas and ovens for continuous lamination/casting operations.

To calculate the annual uncontrolled and controlled VOC emissions from the wet-out areas and from the ovens of continuous lamination/casting operations, the owner or operator shall develop uncontrolled and controlled wet-out area and uncontrolled and controlled oven VOC emissions estimation equations or factors to apply to each formula applied on each line, determine how much of each formula for each end product is applied each year on each line, and assign uncontrolled and controlled wet-out area and uncontrolled and controlled oven VOC emissions estimation equations or factors to each formula. The owner or operator shall determine the overall capture efficiency using the procedures in 40 CFR 63.5850.

- (1) To develop uncontrolled and controlled VOC emissions estimation equations and factors, the owner or operator shall, at a minimum, do the following:
- (a) Identify each end product and the thickness of each end product produced on the line. Separate end products into the following end product groupings, as applicable: corrosion-resistant gel coated end products, noncorrosion-resistant gel coated end products, corrosion-resistant non-gel coated end

products, and noncorrosion-resistant non-gel coated end products. This step creates end product/thickness combinations.

- (b) Identify each formula used on the line to produce each end product/thickness combination. Identify the amount of each such formula applied per year. Rank each formula used to produce each end product/thickness combination according to usage within each end product/thickness combination.
 - (c) For each end product/thickness combination being produced, select the formula with the highest usage rate for testing.
 - (d) If not already selected, also select the worst-case formula (likely to be associated with the formula with the highest monomer content, type of monomer, application of gel coat, thin product, low line speed, higher resin table temperature) amongst all formulae. (The owner or operator may use the results of the worst-case formula test for all formulae if desired to limit the amount of testing required.)
 - (e) For each formula selected for testing, conduct at least one test (consisting of three runs). During the test, track information on monomer content and type of monomer, end product thickness, line speed, and resin temperature on the wet-out area table.
 - (f) Using the test results, develop uncontrolled and controlled VOC emissions estimation equations (or factors) or series of equations (or factors) that best fit the results for estimating uncontrolled and controlled VOC emissions, taking into account the monomer content and type of monomer, end product thickness, line speed, and resin temperature on the wet-out area table.
- (2) In lieu of using the method specified in paragraph (J)(1) of this rule for developing uncontrolled and controlled VOC emissions estimation equations and factors, the owner or operator may use either of the following methods:
- (a) For either uncontrolled or controlled VOC emissions estimates, the owner or operator may use previously established, facility-specific VOC emissions equations or factors, provided ~~they~~ the owner or operator allow estimation of both wet-out area and oven VOC emissions, where necessary, and have been approved by the appropriate Ohio EPA district office or local air agency. If a previously established equation or factor is specific to the wet-out area only, or to the oven only, then the owner or operator shall

develop the corresponding uncontrolled or controlled equation or factor for the other VOC emissions source.

- (b) For uncontrolled (controlled) VOC emissions estimates, the owner or operator may use controlled (uncontrolled) VOC emissions estimates and control device destruction efficiency to calculate ~~your~~the uncontrolled (controlled) VOC emissions provided the control device destruction efficiency was calculated at the same time the owner or operator collected the data to develop ~~your~~the facility's controlled (uncontrolled) VOC emissions estimation equations and factors.
- (3) The owner or operator shall assign to each formula an uncontrolled VOC emissions estimation equation or factor based on the end product/thickness combination for which that formula is used.
- (4) Calculation of annual uncontrolled and annual controlled VOC emissions from wet-out areas and ovens.
 - (a) To calculate the annual uncontrolled VOC emissions from wet-out areas that do not have any capture and control and from wet-out areas that are captured by an enclosure, but are vented to the atmosphere and not to a control device, multiply each formula's annual usage by its appropriate VOC emissions estimation equation or factor and sum the individual results.
 - (b) To calculate the annual uncontrolled VOC emissions that escape from the enclosure on the wet-out area, multiply each formula's annual usage by ~~its~~the appropriate uncontrolled VOC emissions estimation equation or factor, sum the individual results, and multiply the summation by one minus the per cent capture (expressed as a fraction).
 - (c) To calculate the annual uncontrolled oven VOC emissions, multiply each formula's annual usage by ~~its~~the appropriate uncontrolled VOC emissions estimation equation or factor and sum the individual results.
 - (d) To calculate the annual controlled VOC emissions, multiply each formula's annual usage by ~~its~~the appropriate VOC emissions estimation equation or factor and sum the individual results to obtain total annual controlled VOC emissions.
- (5) Where a facility is calculating both uncontrolled and controlled VOC emissions estimation equations and factors, the owner or operator shall test the same

formulae. In addition, the owner or operator shall develop both sets of equations and factors from the same tests.

(K) Determination of the capture efficiency of the enclosure on the wet-out area and the capture efficiency of the oven for continuous lamination/casting operations.

(1) The capture efficiency of a wet-out area enclosure is assumed to be one hundred per cent if it meets the design and operation requirements for a permanent total enclosure (PTE) specified in USEPA method 204 of 40 CFR part 51, appendix M. If a PTE does not exist, then a temporary total enclosure shall be constructed and verified using USEPA method 204, and capture efficiency testing shall be determined using USEPA methods 204B to E of 40 CFR part 51, appendix M.

(2) The capture efficiency of an oven is to be considered one hundred per cent, provided the oven is operated under negative pressure.

(L) Procedures to determine how much neat resin plus is applied to the line and how much neat gel coat plus is applied to the line for continuous lamination/casting operations.

Use the following procedures to determine how much neat resin plus and neat gel coat plus is applied to the line each year:

(1) Track formula usage by end product/thickness combinations.

(2) Use in-house records to show usage. This may be either from automated systems or manual records.

(3) Record daily the usage of each formula/end product combination on each line. This is to be recorded at the end of each run (i.e., when a changeover in formula or product is made) and at the end of each shift.

(4) Sum the amounts from the daily records to calculate annual usage of each formula/end product combination by line.

(M) Calculation of per cent reduction to demonstrate compliance for continuous lamination/casting operations.

The owner or operator shall calculate per cent reduction for continuous lamination/casting operations using any of the following methods:

(1) Compliant line option.

If all of the wet-out areas have a PTE that meets USEPA method 204 of 40 CFR part 51, appendix M, and all of the wet-out area VOC emissions and oven VOC

emissions are vented to an add-on control device, use the equation in paragraph (M)(1)(a) of this rule to demonstrate compliance. In all other situations, use the equation in paragraph (M)(1)(b) of this rule to demonstrate compliance.

(a)

STRIKE OLD

$$PR = \frac{(\text{Inlet}) - (\text{Outlet})}{(\text{Inlet})} \times 100$$

$$PR = ((\text{Inlet} - \text{Outlet}) / \text{Inlet}) \times 100$$

where:

PR = per cent reduction.

Inlet = VOC emissions entering the control device, pounds of VOC per year.

Outlet = VOC emissions exiting the control device to the atmosphere, pounds of VOC per year.

(b)

STRIKE OLD

$$PR = \frac{(WAE_{ci} + O_{ci}) - (WAE_{co} + O_{co})}{(WAE_{ci} + WAE_u + O_{ci} + O_u)} \times 100$$

$$PR = (((WAE_{ci} + O_{ci}) - (WAE_{co} + O_{co})) / (WAE_{ci} + WAE_u + O_{ci} + O_u)) \times 100$$

where:

PR = per cent reduction.

O_{ci} = oven VOC emissions, pounds of VOC per year, vented to a control device.

O_{co} = oven VOC emissions, pounds of VOC per year, from the control device outlet.

O_u = oven VOC emissions, pounds of VOC per year, not vented to a control device.

WAE_{ci} = wet-out area VOC emissions, pounds of VOC per year, vented to a control device.

WAE_{co} = wet-out area VOC emissions, pounds of VOC per year, from the control device outlet.

WAE_u = wet-out area VOC emissions, pounds of VOC per year, not vented to a control device.

(2) Averaging option.

Use the following equation to calculate per cent reduction:

$$PR = \frac{\left(\sum_{i=1}^m WAE_{i_{ci}} + \sum_{j=1}^n O_{j_{ci}} \right) - \left(\sum_{i=1}^m WAE_{i_{co}} + \sum_{j=1}^n O_{j_{co}} \right)}{\left(\sum_{i=1}^m WAE_{i_{ci}} + \sum_{j=1}^n O_{j_{ci}} + \sum_{i=1}^m WAE_{i_u} + \sum_{j=1}^n O_{j_u} \right)}$$

where:

PR = per cent reduction.

$O_{j_{ci}}$ = VOC emissions from oven j, pounds of VOC per year, sent to a control device.

$O_{j_{co}}$ = VOC emissions from oven j, pounds of VOC per year, at the outlet of the control device.

O_{ju} = VOC emissions from oven j, pounds of VOC per year, not sent to a control device.

WAE_{ci} = wet-out area VOC emissions from wet-out area i, pounds of VOC per year, sent to a control device.

WAE_{co} = wet-out area VOC emissions from wet-out area i, pounds of VOC per year, at the outlet of a control device.

WAE_{u} = wet-out area VOC emissions from wet-out area i, pounds of VOC per year, not sent to a control device.

m = number of wet-out areas.

n = number of ovens.

(3) Add-on control device option.

Use the equation in paragraph (M)(1)(a) of this rule to calculate per cent reduction.

(4) Combination option.

Use the equations in paragraphs (M)(1)(a), (M)(1)(b), and (M)(2) of this rule, as applicable, to calculate per cent reduction.

(N) Calculation of a VOC emissions factor to demonstrate compliance for continuous lamination/casting operations.

(1) Compliant line option.

Use the following equation to calculate a VOC emissions factor in pounds of VOC per ton of neat resin plus and neat gel coat plus.

STRIKE OLD

$$E = \frac{WAE_u + WAE_c + O_u + O_c}{(R + G)}$$

$$E = (WAE_u + WAE_c + O_u + O_c) / (R + G)$$

where:

E = VOC emissions factor in pounds of VOC per ton of neat resin plus and neat gel coat plus.

WAE_u = uncontrolled wet-out area VOC emissions, pounds of VOC per year.

WAE_c = controlled wet-out area VOC emissions, pounds of VOC per year.

O_u = uncontrolled oven VOC emissions, pounds of VOC per year.

O_c = controlled oven VOC emissions, pounds of VOC per year.

R = total usage of neat resin plus, tons per year.

G = total usage of neat gel coat plus, tons per year.

(2) Averaging option.

Use the following equation to demonstrate compliance:

$$E = \frac{\sum_{i=1}^m WAE_{ui} + \sum_{i=1}^o WAE_{ci} + \sum_{j=1}^n O_{uj} + \sum_{j=1}^p O_{cj}}{(R + G)}$$

where:

E = VOC emissions factor in pounds of VOC per ton of resin and gel coat.

WAE_{ui} = uncontrolled VOC emissions from wet-out area i, pounds of VOC per year.

WAE_{ci} = controlled VOC emissions from wet-out area i, pounds of VOC per year.

O_{uj} = uncontrolled VOC emissions from oven j, pounds of VOC per year.

O_{cj} = controlled VOC emissions from oven j, pounds of VOC per year.

i = number of wet-out areas.

j = number of ovens.

m = number of wet-out areas uncontrolled.

n = number of ovens uncontrolled.

o = number of wet-out areas controlled.

p = number of ovens controlled.

R = total usage of neat resin plus, tons per year.

G = total usage of neat gel coat plus, tons per year.

(3) Combination option.

Use the equations in paragraphs (N)(1) and (N)(2) of this rule, as applicable, to demonstrate compliance.

(O) Demonstration of continuous compliance and the associated monitoring and data collection requirements.

(1) Demonstration of continuous compliance.

(a) The owner or operator shall demonstrate continuous compliance with each VOC control requirement in paragraph (D) of this rule that applies to the affected operations according to the following methods:

(i) Compliance with VOC emissions limits for affected operations using add-on control devices is demonstrated by following the procedures in 40 CFR part 63, subpart SS, which include the use of continuous parameter monitors. Affected operations using add-on control devices may also use continuous emissions monitors to demonstrate continuous compliance as an alternative to continuous parameter monitors.

(ii) Compliance with VOC emissions limits is demonstrated by maintaining a VOC emissions factor value less than or equal to the appropriate VOC emissions limit listed in table 2 or table 3 of this rule, on a twelve-month rolling average, or by including in each

compliance report a statement that individual resins and gel coats, as applied, meet the appropriate VOC emissions limits, as discussed in paragraph (O)(2)(c) of this rule.

- (iii) Compliance with monomer content limits in table 4 of this rule is demonstrated by maintaining an average monomer content value less than or equal to the appropriate monomer contents listed in table 4 of this rule, on a twelve-month rolling average, or by including in each compliance report a statement that resins and gel coats individually meet the appropriate monomer content limits in table 4 of this rule, as discussed in paragraph (G)(4)(d) of this rule.
 - (iv) Compliance with the work practice standards in table 1 of this rule is demonstrated by performing the work practice required for the affected operation.
- (b) The owner or operator shall report each deviation from each VOC control requirement in paragraph (D) of this rule that applies. The deviations shall be reported according to paragraph (Q) of this rule.
 - (c) Except as provided in paragraph (O)(1)(d) of this rule, during periods of startup, shutdown or malfunction, the owner or operator shall meet the VOC emissions limits and work practice standards that apply.
 - (d) When an add-on control device is used to meet a VOC control requirement in paragraph (D) of this rule, the owner or operator is not required to meet that VOC control requirement during periods of startup, shutdown, or malfunction, but the owner or operator shall operate the affected operation to minimize emissions to the greatest extent which is consistent with safety and good air pollution control practice.
 - (e) Deviations that occur during a period of malfunction for those affected operations and standards specified in paragraph (O)(1)(d) of this rule are not violations if the owner or operator demonstrates to the director's satisfaction that the owner or operator was operating in accordance with paragraph (O)(1)(d) of this rule. The director will determine whether deviations that occur during a period of startup, shutdown, and malfunction are violations.
- (2) Monitoring and data collection requirements to demonstrate continuous compliance.

- (a) If using an add-on control device, the owner or operator shall during production collect and keep a record of data as indicated in 40 CFR part 63, subpart SS and shall monitor and collect the following data:
- (i) Except for monitoring malfunctions, associated repairs, and required quality assurance or control activities (including, as applicable, calibration checks and required zero and span adjustments), the owner or operator shall conduct all monitoring in continuous operation (or collect data at all required intervals) at all times that the controlled operation is operating.
 - (ii) The owner or operator may not use data recorded during monitoring malfunctions, associated repairs, and required quality assurance or control activities for purposes of this rule, including data averages and calculations, or fulfilling a minimum data availability requirement, if applicable. The owner or operator shall use all the data collected during all other periods in assessing the operation of the control device and associated control system.
 - (iii) At all times, the owner or operator shall maintain necessary parts for routine repairs of the monitoring equipment.
 - (iv) A monitoring malfunction is any sudden, infrequent, not reasonably preventable failure of the monitoring equipment to provide valid data. Monitoring failures that are caused in part by poor maintenance or careless operation are not malfunctions.
- (b) For meeting any VOC emissions limits based on a VOC emissions limit specified in table 2 or table 3 of this rule, the owner or operator shall collect and keep records of resin and gel coat use, monomer content, and operation where the resin is used. If the owner or operator is averaging monomer contents to meet any monomer content limits specified in table 4 of this rule, the owner or operator shall collect and keep records of resin and gel coat use, monomer content, and operation where the resin is used. Resin use records may be based on purchase records if the owner or operator can reasonably estimate how the resin is applied. The monomer content records may be based on MSDS or on resin specifications supplied by the resin supplier.
- (c) Resin and gel coat use records are not required for the individual resins and gel coats that are demonstrated, as applied, to meet their applicable emission limit as defined in paragraph (G)(1) of this rule. However, the owner or operator shall retain the records of resin and gel coat

monomer content, and the owner or operator shall include the list of these resins and gel coats and identify their application methods in the semiannual compliance reports. If after the owner or operator has initially demonstrated that a specific combination of an individual resin or gel coat, application method, and controls meets an applicable emission limit, and the resin or gel coat changes or the monomer content increases, or the owner or operator changes the application method or controls, then the owner or operator again shall demonstrate that the individual resin or gel coat meets its emission limit as specified in paragraph (G)(1) of this rule. If any of the previously mentioned changes results in a situation where an individual resin or gel coat exceeds its applicable emission limit in table 2 or table 3 of this rule, the owner or operator shall begin collecting resin and gel coat use records and calculate compliance using one of the averaging options on a twelve-month rolling average.

- (d) For each pultrusion machine, the owner or operator shall record all times that doors or covers of wet area enclosures are open and there is resin present in the resin bath.

(P) Recordkeeping.

(1) The owner or operator shall keep the following records:

- (a) A copy of each applicability notification and compliance status report submitted to comply with this rule, including all documentation supporting any applicability or compliance status.
- (b) For any add-on control device, all records required in 40 CFR part 63, subpart SS, to show continuous compliance with this rule.
- (c) For operations listed in tables 2, 3, and 4 of this rule all data, assumptions, and calculations used to determine monomer contents and VOC emissions factors.
- (d) For any continuous laminating/casting operation:
 - (i) All data, assumptions, and calculations used to determine monomer contents, VOC emissions factors, per cent reduction of VOC emissions, or pounds of VOC per ton as applicable.
 - (ii) A brief description of the rationale for the assignment of a VOC emissions equation or VOC emissions factor to each resin or gel coat formula.

- (iii) When using facility-specific VOC emissions estimation equations or factors, all data, assumptions, and calculations used to derive the VOC emissions estimation equations and factors and identification and rationale for the worst-case resin or gel coat formula.
 - (iv) For all VOC emissions estimation equations and VOC emissions factors, documentation that USEPA has approved them. This requirement does not apply to VOC emissions estimation equations and VOC emissions factors found in table 1 of 40 CFR part 63, subpart WWWW or AP-42.
 - (e) A certified statement that operations are in compliance with the work practice standards specified in table 1 of this rule, as applicable.
- (2) Regardless of any exclusion in paragraph (A)(2)(e) of this rule, the owner or operator of a SMC manufacturing machine shall keep the following records:
 - (a) Monthly production records of the following operational data for each SMC manufacturing machine:
 - (i) The amount of SMC produced for each type of SMC product.
 - (ii) The monomer content of each SMC product.
 - (b) Monthly VOC emissions records for each SMC manufacturing machine that show the VOC emissions factor used for each SMC product, including a citation of the source of the emission factor, and the results of the VOC emission calculations.
- (3) For any uncontrolled SMC manufacturing machine exempted under paragraph (D)(9) of this rule, the owner or operator shall record the VOC emissions from that SMC manufacturing machine for the recent month and rolling twelve-month period within fifteen days after the end of each month. The owner or operator shall notify the appropriate Ohio EPA district office or local air agency of any record showing the SMC manufacturing machine exceeded the applicable VOC emissions limit. A copy of such record shall be sent to the appropriate Ohio EPA district office or local air agency within forty-five days after the exceedance occurs.
- (4) All records specified under paragraphs (P)(1) to (P)(3) of this rule shall be retained by the owner or operator for a period of not less than five years following the date of each occurrence, measurement, maintenance, corrective action, report, or record and shall be made available to the director or any authorized representative of the director for review during normal business hours.

(Q) Reporting.

- (1) The owner or operator of a facility that has reinforced plastic composites production operations subject to this rule shall submit semiannual compliance status reports containing the information specified in paragraphs (Q)(3)(a) to (Q)(3)(h) of this rule. The semiannual compliance status reports shall be submitted no later than thirty calendar days after the end of each six-month period to the appropriate Ohio EPA district office or local air agency. The first compliance report shall cover the period beginning on the compliance date that is specified in paragraph (R) of this rule and ending on June thirtieth or December thirty-first, whichever date is the first date following the end of the first calendar half after the compliance date that is specified in paragraph (R) of this rule. Each subsequent compliance report shall cover the semiannual reporting period from January first through June thirtieth or the semiannual reporting period from July first through December thirty-first.
- (2) For each facility that is subject to permitting requirements pursuant to Chapter 3745-77 of the Administrative Code (pertaining to Title V permits), the owner or operator may submit the first and subsequent semiannual compliance reports according to the dates established within the facility's Title V permit, instead of according to the dates specified in paragraph (Q)(1) of this rule.
- (3) The compliance report shall contain the following information:
 - (a) Company name and address.
 - (b) Statement by a responsible official with that official's name, title, and signature, certifying the truth, accuracy, and completeness of the content of the report.
 - (c) Date of the report and beginning and ending dates of the reporting period.
 - (d) If there are no deviations from any VOC emissions limitations and operating limits that apply and there are no deviations from the work practice standards in table 1 of this rule, a statement that there were no deviations from VOC emissions limitations, operating limits, or work practice standards during the reporting period.
 - (e) If there were no periods during which a continuous monitoring system (CMS), including a continuous emissions monitoring system and a continuous parameter monitoring system, were out of control, a statement that there were no periods during which the CMS was out of control during the reporting period.

- (f) For each deviation from a VOC emissions limitation or operating limit and for each deviation from a work practice standard that occurs at an affected operation where a CMS is not used to comply with the VOC emissions limitation, operating limit, or work practice standard in this rule, the compliance report shall contain the following information:
- (i) The total operating time of each affected operation during the reporting period.
 - (ii) Information on the number, duration, and cause of deviations (including unknown cause, if applicable), as applicable, and the corrective action taken.
- (g) For each deviation from an VOC emissions limitation or operating limit that occurs at an affected operation where a CMS is used to comply with the VOC emissions limitation or operating limit in this rule, the compliance report shall include the following information:
- (i) The date and time that each malfunction started and stopped.
 - (ii) The date and time that each CMS was inoperative, except for zero (low-level) and high-level checks.
 - (iii) The date, time, and duration that each CMS was out of control, as defined in paragraph (c)(7) of 40 CFR 63.8, including the information in paragraph (c)(8) of 40 CFR 63.8.
 - (iv) The date and time that each deviation started and stopped, and whether each deviation occurred during a period of startup, shutdown, or malfunction, or during another period.
 - (v) A summary of the total duration of the deviation during the reporting period and the total duration as a per cent of the total source operating time during that reporting period.
 - (vi) A breakdown of the total duration of the deviations during the reporting period into those that are due to startup, shutdown, control equipment problems, process problems, other known causes, and other unknown causes.
 - (vii) A summary of the total duration of CMS downtime during the reporting period and the total duration of CMS downtime as a per cent of the total source operating time during that reporting period.

- (viii) An identification of each VOC that was monitored at the affected source.
 - (ix) A brief description of the affected operations.
 - (x) A brief description of the CMS.
 - (xi) The date of the latest CMS certification or audit.
 - (xii) A description of any changes in CMS, processes, or controls since the last reporting period.
- (h) Where multiple compliance options are available, the owner or operator shall state in this compliance report if the owner or operator has changed compliance options since the last compliance report.
- (4) The owner or operator shall report if the facility exceeded the one hundred tons of VOC per year emissions threshold if that exceedance would make the facility subject to paragraph (D)(3) of this rule.
- (5) Each facility that has obtained a Title V permit pursuant to Chapter 3745-77 of the Administrative Code shall report all deviations as described in this rule in the semiannual monitoring report required by the Title V permit. If the facility submits a semiannual compliance report pursuant to this rule along with, or as part of, the semiannual monitoring report required by the facility's Title V permit, and the semiannual compliance report includes all required information concerning deviations from any VOC emissions limitation, operating limit, or work practice standard in this rule, submission of the semiannual compliance report shall be deemed to satisfy any obligation to report the same deviations in the semiannual monitoring report. However, submission of a compliance report shall not otherwise affect any obligation the affected source may have to report deviations from permit requirements to the appropriate Ohio EPA district office or local air agency.

(R) Compliance dates.

- (1) Except where otherwise specified within this rule, any owner or operator of an affected operation that is subject to this rule shall comply with this rule by no later than the following dates:
- (a) For any affected operation for which installation commenced before December 14, 2009, the compliance date of the affected operation is the initial startup of the affected operation or December 14, 2010, whichever is later.

- (b) For any affected operation for which installation commenced on or after December 14, 2009, the compliance date of the affected operation is the date of initial startup of the affected operation.
- (2) If the reinforced plastic composites production facility has VOC emissions less than the threshold of one hundred tons of VOC per year from the combination of all open molding, centrifugal casting, continuous lamination/casting, pultrusion, SMC manufacturing, mixing, and BMC manufacturing, and the facility subsequently increases VOC emissions to meet or exceed the threshold of one hundred tons of VOC per year from the combination of such operations, the compliance date of any affected operation pertaining to a new VOC emission requirement is two years from the date that the semiannual compliance report indicates the facility meets or exceeds the threshold of one hundred tons of VOC per year.
- (3) In the event an uncontrolled SMC manufacturing machine is exempted under paragraph (D)(9) of this rule and is later equipped with a VOC emission control system, the compliance date of the SMC manufacturing machine pertaining to paragraph (D)(8) of this rule is the date of first startup of the installed VOC emission control system for the SMC manufacturing machine. Until the date of first startup of the installed VOC emission control system for the SMC manufacturing machine, the SMC manufacturing machine shall continue to comply with paragraph (D)(9) of this rule.
- (4) If an affected operation is vented to an add-on control to meet a VOC emissions requirement specified within the rule, the owner or operator shall demonstrate compliance by testing the operation and the add-on control device in accordance with this rule within ninety days after the compliance date of the affected operation.
- (5) Additional testing of an affected operation vented to an add-on control may be required by the director to ensure continued compliance.
- (S) Applicability notification, permit application, and testing notification.
- (1) The owner or operator of an affected operation, as described in paragraph (C) of this rule, that is subject to this rule and that has an initial startup date before December 14, 2009 shall notify the appropriate Ohio EPA district office or local air agency in writing that such operation is subject to this rule. The notification, which shall be submitted not later than February 12, 2010, shall provide the following information:
- (a) Name and address of the owner or operator.

- (b) Address (i.e., physical location) of the facility.
 - (c) Equipment description and Ohio EPA application number (if assigned) of the affected operation.
 - (d) Identification of the applicable requirements, the means of compliance, and the compliance date for the affected operation under this rule.
 - (e) An application for an operating permit or an application for a modification to an operating permit in accordance with Chapter 3745-77 of the Administrative Code (for sources subject to the Title V permit program) or an application for a permit-to-install and operate or an application for a modification to a permit-to-install and operate in accordance with Chapter 3745-31 of the Administrative Code (for sources not subject to the Title V permit program) for each subject process that meets one of the following:
 - (i) The process does not possess an effective operating permit or permit-to-install and operate.
 - (ii) The process possesses an effective operating permit or permit-to-install and operate and the owner or operator cannot certify in writing to the director that such subject process is in compliance with this rule. An application for an operating permit or permit-to-install and operate is not required provided the subject process is operating under an effective permit and certifies compliance. Such certification shall include all compliance certification requirements under paragraph (Q)(3) of this rule.
- (2) The owner or operator of an affected operation, as described in paragraph (C) of this rule, that is subject to this rule and that has an initial startup date on or after December 14, 2009 shall notify the appropriate Ohio EPA district office or local air agency in writing that the affected operation is subject to this rule. The notification, which shall be submitted not later than either the date of initial startup of the affected operation or February 12, 2010, whichever is later, shall provide the information listed under paragraph (F)(1) of this rule. The application for a permit to install under rule 3745-31-02 of the Administrative Code may be used to fulfill the notification requirements of this paragraph.
- (3) For the compliance testing of an affected operation that is vented to an add-on control device to meet a VOC emissions requirement specified within this rule, the owner or operator shall submit an intent to test that is in accordance with

the procedures of paragraph (A) of rule 3745-21-10 of the Administrative Code and that includes the test procedures specified within this rule.

Table 1: Work practice standards. As required in paragraph (D)(1) of this rule, the owner or operator shall meet the work practice standards specified by type of operation in the following table:

Type of operation	Work practice standards
1. Compression/injection molding	Uncover, unwrap or expose only one charge per mold cycle per compression/injection molding machine. For machines with multiple molds, one charge means sufficient material to fill all molds for one cycle. For machines with robotic loaders, no more than one charge may be exposed prior to the loader. For machines fed by hoppers, sufficient material may be uncovered to fill the hopper. Hoppers shall be closed when not adding materials. Materials may be uncovered to feed to slitting machines. Materials shall be recovered after slitting.
2. Cleaning operation (cleaning of equipment used in reinforced plastic composites manufacture)	Do not use cleaning solvents (cleaners) that have a VOC content greater than 0.42 pound VOC per gallon, except cleaners used in closed systems and used to clean cured resin from application equipment. Application equipment includes any equipment that directly contacts resin.
3. VOC-containing materials storage operation	Keep containers that store VOC-containing materials closed or covered except during the addition or removal of materials. Bulk VOC-containing materials storage tanks may be vented as necessary for safety.
4. SMC manufacturing operation	a. Close or cover the resin delivery system to the doctor box on each SMC manufacturing machine. The doctor box itself may be open.

	b. Use a nylon containing film to enclose SMC.
5. All mixing or BMC manufacturing operations ¹	a. Use mixer covers with no visible gaps present in the mixer covers, except that gaps of up to 1.0 inch are permissible around mixer shafts and any required instrumentation.
	b. Close any mixer vents when actual mixing is occurring, except that venting is allowed during addition of materials, or as necessary prior to adding materials or opening the cover for safety. Vents routed to a ninety-five per cent efficient control device are exempt from this requirement.
	c. Keep the mixer covers closed while actual mixing is occurring except when adding materials or changing covers to the mixing vessels.
6. Pultrusion operation manufacturing parts that meet the following criteria: one thousand or more reinforcements or the glass equivalent of one thousand ends of one hundred thirteen yield roving or more; and have a cross-sectional area of sixty square inches or more that is not subject to the ninety-five per cent VOC emissions reduction requirement	a. Do not allow vents from the building ventilation system, or local or portable fans to blow directly on or across the wet-out area.
	b. Do not permit point suction of ambient air in the wet-out area unless that air is directed to a control device.
	c. Use devices such as deflectors, baffles, and curtains when practical to reduce air flow velocity across the wet-out area.
	d. Direct any compressed air exhausts away from resin and wet-out area.

	e. Convey resin collected from drip-off pans or other devices to reservoirs, tanks, or sumps via covered troughs, pipes, or other covered conveyance that shields the resin from the ambient air.
	f. Cover all reservoirs, tanks, sumps, or VOC-containing materials storage vessels except when they are being charged or filled.
	g. Cover or shield from ambient air resin delivery systems to the wet-out area from reservoirs, tanks, or sumps where practical.

¹Containers of five gallons or less may be open when active mixing is taking place, or during periods when they are in process (i.e., they are actively being used to apply resin). For polymer casting mixing operations, containers with a surface area of five hundred square inches or less may be open while active mixing is taking place.

Table 2: VOC Emissions limits for specific open molding, centrifugal casting, pultrusion and continuous lamination/casting operations at facilities with VOC emissions less than the threshold of one hundred tons of VOC per year. As required in paragraph (D)(2) of this rule, the owner or operator shall meet the VOC emissions limits specified by type of operation and resin application method or gel coat type in the following table:

Type of operation	Resin application method or gel coat type	VOC emissions limit ¹
1. Open molding: corrosion-resistant and/or high strength (CR/HS)	a. Mechanical resin application	113 lb/ton
	b. Filament application	171 lb/ton
	c. Manual resin application	123 lb/ton
2. Open molding: non-CR/HS	a. Mechanical resin application	88 lb/ton
	b. Filament application	188 lb/ton
	c. Manual resin application	87 lb/ton

3. Open molding: tooling	a. Mechanical resin application	254 lb/ton
	b. Manual resin application	157 lb/ton
4. Open molding: low-flame spread/low-smoke products	a. Mechanical resin application	497 lb/ton
	b. Filament application	270 lb/ton
	c. Manual resin application	238 lb/ton
5. Open molding: shrinkage controlled resins ²	a. Mechanical resin application	354 lb/ton
	b. Filament application	215 lb/ton
	c. Manual resin application	180 lb/ton
6. Open molding: gel coat ³	a. Tooling gel coat	440 lb/ton
	b. White/off white pigmented gel coat	267 lb/ton
	c. All other pigmented gel coat	377 lb/ton
	d. CR/HS or high performance gel coat	605 lb/ton
	e. Fire retardant gel coat	854 lb/ton
	f. Clear production gel coat	522 lb/ton
7. Centrifugal casting: CR/HS	a. Resin application with the mold closed, and the mold is vented during spinning and cure	25 lb/ton ⁴
	b. Resin application with the mold closed, and the mold is not vented during spinning and cure	Not applicable (this is considered to be a closed molding operation)

	c. Resin application with the mold open, and the mold is vented during spinning and cure	25 lb/ton ⁴
	d. Resin application with the mold open, and the mold is not vented during spinning and cure	Use the appropriate open molding emission limit ⁵
8. Centrifugal casting: non-CR/HS	a. Resin application with the mold closed, and the mold is vented during spinning and cure	20 lb/ton ⁴
	b. Resin application with the mold closed, and mold is not vented during the spinning and cure	Not applicable (this is considered to be a closed molding operation)
	c. Resin application with the mold open, and the mold is vented during spinning and cure	20 lb/ton ⁴
	d. Resin application with the mold open, and the mold is not vented during spinning and cure	Use the appropriate open molding emission limit ⁵
9. Pultrusion ⁶	Not applicable	Reduce total VOC emissions by at least sixty per cent by weight
10. Continuous lamination/casting	Not applicable	Reduce total VOC emissions by at least 58.5 per cent by weight or not exceed a VOC emissions limit

		of 15.7 pounds of VOC per ton of neat resin plus and neat gel coat plus
--	--	---

¹VOC emissions limits for open molding and centrifugal casting are expressed as pounds of VOC per ton of resin or gel coat (pounds per ton). The operation shall be at or below these values based on a twelve-month rolling average.

²This emission limit applies regardless of whether the shrinkage controlled resin is used as a production resin or a tooling resin.

³If applying gel coat with manual application, for compliance purposes treat the gel coat as if it were applied using atomized spray guns to determine both emission limits and emission factors. If using multiple application methods and any portion of a specific gel coat is applied using nonatomized spray, the owner or operator may use the nonatomized spray gel coat equation to calculate an emission factor for the manually applied portion of that gel coat. Otherwise, use the atomized spray gel coat application equation to calculate emission factors.

⁴For compliance purposes, calculate the VOC emission factor using only the appropriate centrifugal casting equation in item 2 of table 1 of 40 CFR part 63, subpart WWWW, or a site-specific emission factor for after the mold is closed as discussed in paragraph (E) (1) of this rule.

⁵Calculate ~~your~~the emission factor using the appropriate open molding covered cure emission factor in item 1 of table 1 of 40 CFR part 63, subpart WWWW, or a site-specific emission factor as discussed in paragraph (E)(1) of this rule.

⁶Pultrusion machines that produce parts that meet the following criteria: one thousand or more reinforcements or the glass equivalent of one thousand ends of one hundred thirteen yield roving or more; and have a cross sectional area of sixty square inches or more are not subject to this requirement. ~~Their~~The requirement is the work practice of air flow management which is described in table 1 of this rule.

Table 3: Alternative VOC emissions limits for open molding, centrifugal casting, and continuous lamination/casting operations at facilities with VOC emissions equal to or greater than the threshold of one hundred tons of VOC per year. As provided in paragraph (D)(3) of this rule, as an alternative to the ninety-five per cent VOC emissions reductions requirement, the owner or operator may meet the appropriate VOC emissions limits

specified by type of operation and resin application method, gel coat type, or vent system type in the following table:

Type of operation	Resin application method	VOC emissions limit ¹
1. Open molding: corrosion-resistant and/or high strength (CR/HS)	a. Mechanical resin application	6 lb/ton
	b. Filament application	9 lb/ton
	c. Manual resin application	7 lb/ton
2. Open molding: non-CR/HS	a. Mechanical resin application	13 lb/ton
	b. Filament application	10 lb/ton
	c. Manual resin application	5 lb/ton
3. Open molding: tooling	a. Mechanical resin application	13 lb/ton
	b. Manual resin application	8 lb/ton
4. Open molding: low flame spread/low smoke products	a. Mechanical resin application	25 lb/ton
	b. Filament application	14 lb/ton
	c. Manual resin application	12 lb/ton
5. Open molding: shrinkage controlled resins	a. Mechanical resin application	18 lb/ton
	b. Filament application	11 lb/ton
	c. Manual resin application	9 lb/ton
6. Open molding: gel coat: Open molding: gel coat ²	a. Tooling gel coat	22 lb/ton

	b. White/off white pigmented gel coat	22 lb/ton
	c. All other pigmented gel coat	19 lb/ton
	d. CR/HS or high performance gel coat	31 lb/ton
	e. Fire retardant gel coat	43 lb/ton
	f. Clear production gel coat	27 lb/ton
7. Centrifugal casting: CR/HS ^{3,4}	a. Uses a vent system that moves heated air through the mold	27 lb/ton
	b. Uses a vent system that moves ambient air through the mold	2 lb/ton
8. Centrifugal casting: non-CR/HS ^{3,4}	a. Uses a vent system that moves heated air through the mold	21 lb/ton
	b. Uses a vent system that moves ambient air through the mold	1 lb/ton
9. Continuous lamination/casting	Not applicable	1.47 lb/ton

¹For open molding and centrifugal casting operations, the VOC emissions limits are expressed as pounds of VOC per ton of resin or gel coat used (pound per ton). For a continuous lamination/casting operation, the VOC emissions limit is expressed as pounds of VOC per ton of neat resin plus and neat gel coat plus used. The operations shall be at or below these values based on a twelve-month rolling average.

²These limits are for spray application of gel coat. Manual gel coat application shall be included as part of spray gel coat application for compliance purposes using the same VOC emissions factor equation and VOC emissions limit. If only gel coat is applied with manual

application, treat the manually applied gel coat as if it were applied with atomized spray for compliance determinations.

³Centrifugal casting operations where the mold is not vented during spinning and cure are considered to be closed molding and are not subject to any emissions limit. Centrifugal casting operations where the mold is not vented during spinning and cure, and the resin is applied to the open centrifugal casting mold using mechanical or manual open molding resin application techniques are considered to be open molding operations and the appropriate open molding emission limits apply.

⁴Centrifugal casting operations where the mold is vented during spinning and the resin is applied to the open centrifugal casting mold using mechanical or manual open molding resin application techniques, are to use the appropriate centrifugal casting emission limit to determine compliance. Calculate the emission factor using the appropriate centrifugal casting emission factor in table 1 of 40 CFR part 63, subpart WWWW, or a site-specific emissions factor as discussed in paragraph (E)(1) of this rule.

Table 4: Options allowing use of the same resin across different operations that use the same resin type. As provided in paragraph (G)(4) of this rule, when electing to use the same resin for multiple resin application methods, the owner or operator may use any resin with a monomer content less than or equal to the values shown in the following table, or any combination of resins whose weighted average monomer content based on a twelve-month rolling average is less than or equal to the values shown in the following table:

Type of operation	Resin application method	Monomer content limit (per cent by weight of resin)
1. CR/HS resins, centrifugal casting ^{1,2}	a. CR/HS mechanical ³	48.0
	b. CR/HS filament application	48.0
	c. CR/HS manual	48.0
2. CR/HS resins, nonatomized mechanical	a. CR/HS filament application	46.4
	b. CR/HS manual	46.4
3. CR/HS resins, filament application	CR/HS manual	42.0

4. Non-CR/HS resins, filament application	a. Non-CR/HS mechanical ³	45.0
	b. Non-CR/HS manual	45.0
	c. Non-CR/HS centrifugal casting ^{1,2}	45.0
5. Non-CR/HS resins, nonatomized mechanical	a. Non-CR/HS manual	38.5
	b. Non-CR/HS centrifugal casting ^{1,2}	38.5
6. Non-CR/HS resins, centrifugal casting ^{1,2}	Non-CR/HS manual	37.5
7. Tooling resins, nonatomized mechanical	Tooling manual	91.4
8. Tooling resins, manual	Tooling atomized mechanical	45.9

¹If the centrifugal casting operation blows heated air through the molds, then ninety-five per cent capture and control shall be used if the owner or operator wishes to use this compliance option.

²If the centrifugal casting molds are not vented, the owner or operator may treat the centrifugal casting operations as if ~~they~~the molds were vented if the owner or operator wishes to use this compliance option.

³Nonatomized mechanical application shall be used.

Effective: 3/27/2022
Five Year Review (FYR) Dates: 11/29/2021 and 11/29/2026

CERTIFIED ELECTRONICALLY

Certification

03/17/2022

Date

Promulgated Under: 119.03
Statutory Authority: 3704.03(E)
Rule Amplifies: 3704.03(A), 3704.03(E)
Prior Effective Dates: 12/14/2009, 11/11/2010, 10/15/2015, 02/16/2019

3745-21-26

Surface coating of miscellaneous metal and plastic parts.**(A) Applicability.**

- (1) Except as provided in paragraph (A)(3) of this rule, paragraphs (B) to (I) of this rule shall apply to each miscellaneous metal or plastic parts coating line that meets the following:
 - (a) The total actual VOC emissions from all miscellaneous metal or plastic parts coating operations, including related cleaning operations, are equal to or greater than 2.7 tons per rolling twelve-month period, before the application of control systems and devices.
 - (b) The facility is located in Ashtabula, Butler, Clermont, Cuyahoga, Geauga, Hamilton, Lake, Lorain, Medina, Portage, ~~or~~ Summit, or Warren county.
- (2) Miscellaneous metal and plastic parts include, but are not limited to, metal and plastic components of the following types of products as well as the products themselves:
 - (a) Large and small farm machinery.
 - (b) Small household appliances.
 - (c) Office equipment.
 - (d) Commercial and industrial machinery and equipment.
 - (e) Fabricated metal products.
 - (f) Molded plastic parts.
 - (g) Automotive or transportation equipment.
 - (h) Interior or exterior automotive parts.
 - (i) Construction equipment.
 - (j) Motor vehicle accessories.
 - (k) Bicycles and sporting goods.
 - (l) Toys.
 - (m) Recreational vehicles.

- (n) Pleasure craft (recreational boats).
- (o) Extruded aluminum structural components.
- (p) Railroad cars.
- (q) Heavier vehicles, except as provided in paragraph (A)(3)(a)(iv) of this rule.
- (r) Lawn and garden equipment.
- (s) Business machines.
- (t) Laboratory and medical equipment.
- (u) Electronic equipment.
- (v) Steel drums.
- (w) Metal pipes.

(3) Exemptions.

(a) Paragraphs (B) to (I) of this rule shall not apply to the following:

(i) The surface coating of any metal or plastic parts or products for which the owner or operator is both subject to and required to comply with any of the following:

(a) Rule 3745-21-20 of the Administrative Code for shipbuilding and repair.

(b) Rule 3745-21-19 of the Administrative Code for aerospace.

(c) Rule 3745-21-15 of the Administrative Code for wood furniture.

(d) Paragraph (I) of rule 3745-21-09 of the Administrative Code for metal furniture.

(e) Paragraph (K) of rule 3745-21-09 of the Administrative Code for large appliances.

(f) Paragraph (C) of rule 3745-21-09 of the Administrative Code or rule 3745-21-29 of the Administrative Code for automobile and light-duty truck assembly.

- (g) Rule 3745-21-24 of the Administrative Code for flatwood paneling.
 - (h) Rule 3745-21-28 of the Administrative Code for miscellaneous industrial adhesives and sealants.
 - (i) Rule 3745-21-27 of the Administrative Code for fiberglass boat manufacturing.
 - (j) Paragraph (F) of rule 3745-21-09 of the Administrative Code for paper, film, and foil.
 - (k) Paragraph (D) of rule 3745-21-09 of the Administrative Code for can coatings.
 - (l) Paragraph (E) of rule 3745-21-09 of the Administrative Code for coil coatings.
 - (m) Paragraph (J) of rule 3745-21-09 of the Administrative Code for magnet wire coatings.
 - (n) Paragraph (G) of rule 3745-21-09 of the Administrative Code for fabric coating.
 - (o) Paragraph (H) of rule 3745-21-09 of the Administrative Code for vinyl coating.
 - (p) Rule 3745-21-25 of the Administrative Code for reinforced plastic composites production operations.
- (ii) Architectural coatings and automobile refinish coatings are not regulated under this rule to the extent the coatings are used for architectural coating or automobile refinish coating purposes as defined in Chapter 3745-113 of the Administrative Code and rule 3745-21-18 of the Administrative Code, respectively.
 - (iii) Aerosol coatings and powder coatings.
 - (iv) The coating of bodies or body parts for new heavier vehicles where the owner or operator elects to comply with rule 3745-21-29 of the Administrative Code.

- (b) Metal parts coatings and coating operations subject to paragraph (S) of rule 3745-21-09 of the Administrative Code are exempt from paragraph (C) of this rule.
- (c) The following metal parts coatings and coating operations are exempt from paragraphs (C) and (D) of this rule:
 - (i) Stencil coatings.
 - (ii) Safety-indicating coatings.
 - (iii) Solid film lubricants.
 - (iv) Electric-insulating and thermal-conducting coatings.
 - (v) Magnetic data storage disk coatings.
 - (vi) Plastic extruded onto metal parts to form a coating.
- (d) The following plastic parts coatings and coating operations are exempt from paragraph (C) of this rule:
 - (i) Touch-up and repair coatings.
 - (ii) Stencil coatings applied on clear or transparent substrates.
 - (iii) Clear or translucent coatings.
 - (iv) Coatings applied at a paint manufacturing facility while conducting performance tests on the coatings.
 - (v) Any individual coating category under paragraph (C) of this rule used in volumes less than fifty gallons in any one calendar year, if substitute compliant coatings are not available, provided that the total usage of all such coatings does not exceed two hundred gallons per calendar year, per facility.
 - (vi) Reflective coating applied to highway cones.
 - (vii) Mask coatings that are less than 0.5 millimeter thick (dried) and the area coated is less than twenty-five square inches.
 - (viii) Electromagnetic interference/radio frequency interference (EMI/RFI) shielding coatings.

- (ix) Heparin-benzalkonium chloride (HBAC) containing coatings applied to medical devices, provided that the total usage of all such coatings does not exceed one hundred gallons per calendar year, per plastic parts coating operation.
- (e) For automotive or transportation and business machine plastic part coating, the following types of coatings and operations are exempt from paragraph (C) of this rule:
- (i) Texture coatings.
 - (ii) Vacuum metallizing coatings.
 - (iii) Gloss reducers.
 - (iv) Texture topcoats.
 - (v) Adhesion primers.
 - (vi) Electrostatic preparation coatings.
 - (vii) Resist coatings.
 - (viii) Stencil coatings.
- (f) Metal parts coating operations are exempt from paragraph (C) of this rule where the following occurs:
- (i) The coating line never uses more than three gallons per day. The daily usage applicability level shall not apply to coatings employed by the coating line on parts or products which are not metal.
 - (ii) The coating operation is a new source, as defined by rule 3745-31-01 of the Administrative Code and meets the following:
 - (a) The construction or modification of the coating operation commenced on or after March 27, 1981.
 - (b) The director has determined that the otherwise applicable emission limitation in paragraph (C) of this rule is technically or economically infeasible and has established an alternative reasonably available control technology emission limitation. The alternative limitation shall be the lowest emission limitation that the coating operation is capable of meeting

by the application of control technology that is reasonably available considering technological and economic feasibility. The alternative limitation shall be an emissions rate (e.g., pounds VOC per gallon) or overall per cent reduction but shall not be in terms of mass per time (e.g., pounds per hour).

(c) A final installation permit has been issued for the coating operation pursuant to Chapter 3745-31 of the Administrative Code. The installation permit shall contain terms and conditions that specify the control requirement or emission limitation that is the basis for the director's alternative limitation determination for the coating line, as described in paragraph (A)(3)(f)(ii)(b) of this rule.

(d) USEPA has approved the alternative limitation as a revision to the Ohio state implementation plan.

(g) The application method requirements in paragraph (D) of this rule do not apply to the following:

(i) For metal parts coatings; touch-up coatings, repair coatings, and textured finishes.

(ii) For plastic parts coatings; airbrush operations using five gallons or less per year of coating.

(iii) For pleasure craft surface coating operations; extreme high gloss coatings.

(B) The definitions applicable to this rule are contained in paragraphs (B) and (D) of rule 3745-21-01 of the Administrative Code.

(C) VOC emission limitations.

The owner or operator of a coating line engaged in the surface coating of miscellaneous metal or plastic parts shall limit VOC emissions from all VOC-containing materials (i.e., coatings, thinners, and any other additives) used by each miscellaneous metal and plastic part surface coating line by complying with one of the following three options. Motor vehicle materials listed in table 5 of this rule may not use option two.

If more than one emission limitation in paragraph (C) of this rule applies to a specific coating, then the least stringent emission limitation may be applied.

If a coating does not meet a specific coating category definition, then it can be assumed to be a general use coating and the VOC limit for "general" coating or "other" coating shall apply.

- (1) Option one. VOC content limitations based on low-VOC coatings as follows in tables 1 to 5 of this rule and the use of application methods specified in paragraph (D) of this rule.

Table 1. - Metal parts and products maximum VOC content limitations (mass of VOC per volume of coating (excluding water and exempt compounds, as applied)).

Coating Category	Air Dried, Pound VOC per Gallon Coating	Baked, Pound VOC per Gallon Coating
General One-Component	2.8	2.3
General Multi-Component	2.8	2.3
Camouflage	3.5	3.5
Electric-Insulating Varnish	3.5	3.5
Etching Filler	3.5	3.5
Extreme High-Gloss	3.5	3.0
Extreme Performance	3.5	3.0
Heat-Resistant	3.5	3.0
High-Performance Architectural	6.2	6.2
High-Temperature	3.5	3.5
Metallic	3.5	3.5
Military Specification	2.8	2.3
Mold-Seal	3.5	3.5
Pan Backing	3.5	3.5
Prefabricated Architectural Multi-Component	3.5	2.3

Prefabricated Architectural One-Component	3.5	2.3
Pretreatment	3.5	3.5
Repair and Touch-Up	3.5	3.0
Silicone Release	3.5	3.5
Solar-Absorbent	3.5	3.0
Vacuum Metallizing	3.5	3.5
Drum, New, Exterior	2.8	2.8
Drum, New, Interior	3.5	3.5
Drum, Reconditioned, Exterior	3.5	3.5
Drum, Reconditioned, Interior	4.2	4.2

Table 2 - Plastic parts and products maximum VOC content limitations (mass of VOC per volume of coating (excluding water and exempt compounds, as applied))

Coating Category	Pound VOC per Gallon Coating
General One-Component	2.3
General Multi-Component	3.5
Electric-Dissipating and Shock-Free	6.7
Extreme Performance	3.5 (2-pack coatings)
Metallic	3.5
Military Specification	2.8 (1-pack), 3.5 (2-pack)
Mold-Seal	6.3
Multi-Colored	5.7
Optical	6.7

Vacuum Metallizing	6.7
--------------------	-----

Table 3 - Automotive/transportation and business machine plastic parts maximum VOC content limitations (mass of VOC per volume of coating (excluding water and exempt compounds, as applied))

Coating Category	Pound VOC per Gallon Coating
--Automotive/Transportation Coatings*--	
High-Bake - Interior and Exterior Parts	
Flexible Primer	4.5
Non-Flexible Primer	3.5
Basecoat	4.3
Clearcoat	4.0
Non-Basecoat/Clearcoat	4.3
Low-Bake/Air Dried - Exterior Parts	
Primer	4.8
Basecoat	5.0
Clearcoat	4.5
Non-Basecoat/Clearcoat	5.0
Low-Bake/Air Dried - Interior Parts	5.0
Touch-Up and Repair	5.2
--Business Machine Coatings--	
Primers	2.9

Topcoat	2.9
Texture Coat	2.9
Fog Coat	2.2
Touch-Up and Repair	2.9

* For red, yellow, and black automotive coatings, except touch-up and repair coatings, the recommended limitation is determined by multiplying the appropriate limitation in table 3 of this rule by 1.15.

Table 4 - Pleasure craft surface coating maximum VOC content limitations (mass of VOC per volume of coating (excluding water and exempt compounds, as applied))

Coating Category	Pound VOC per Gallon Coating
Extreme High-Gloss Topcoat	5.0
High-Gloss Topcoat	3.5
Pretreatment Wash Primer	6.5
Finish Primer/Surfacer	3.5
High-Build Primer/Surfacer	2.8
Antifouling Sealer/Tie Coat	3.5
Aluminum Substrate Antifoulant	4.7
Other Substrate Antifoulant	3.3
All Other Pleasure Craft Surface Coatings for Metal or Plastic	3.5

Table 5 - Motor vehicle materials maximum VOC content limitations (mass of VOC per volume of coating (excluding water and exempt compounds, as applied))

Coating Category	Pound VOC per Gallon Coating
Motor Vehicle Cavity Wax	5.4
Motor Vehicle Sealer	5.4

Motor Vehicle Deadener	5.4
Motor Vehicle Gasket/Gasket Sealing Material	1.7
Motor Vehicle Underbody	5.4
Motor Vehicle Trunk Interior	5.4
Motor Vehicle Bedliner	1.7
Motor Vehicle Lubricating Wax/Compound	5.8

(2) Option two. VOC content limitations based on low-VOC coatings as follows in tables 6 to 9 of this rule, the use of add-on air pollution control equipment to meet the VOC content limitations, and the use of application methods specified in paragraph (D) of this rule. Such add-on air pollution control equipment shall meet paragraph (F) of this rule.

Table 6 - Metal parts and products maximum VOC emission rate limitations (mass of VOC per volume solids, as applied)

Coating Category	Air Dried, Pound VOC per Gallon Solids	Baked, Pounds VOC per Gallon Solids
General One-Component	4.5	3.4
General Multi-Component	4.5	3.4
Camouflage	6.7	6.7
Electric-Insulating Varnish	6.7	6.7
Etching Filler	6.7	6.7
Extreme High-Gloss	6.7	5.1
Extreme Performance	6.7	5.1
Heat-Resistant	6.7	5.1
High-Performance Architectural	38.0	38.0
High-Temperature	6.7	6.7

Metallic	6.7	6.7
Military Specification	4.5	3.4
Mold-Seal	6.7	6.7
Pan Backing	6.7	6.7
Prefabricated Architectural Multi-Component	6.7	3.4
Prefabricated Architectural One-Component	6.7	3.4
Pretreatment	6.7	6.7
Silicone Release	6.7	6.7
Solar-Absorbent	6.7	5.1
Vacuum Metallizing	6.7	6.7
Drum, New, Exterior	4.5	4.5
Drum, New, Interior	6.7	6.7
Drum, Reconditioned, Exterior	6.7	6.7
Drum, Reconditioned, Interior	9.8	9.8

Table 7 - Plastic parts and products maximum VOC emission rate limitations (VOC per volume solids)

Coating Category	Pound VOC per Gallon Solids
General One-Component	3.4
General Multi-Component	6.7
Electric-Dissipating and Shock-Free	74.7
Extreme Performance	6.7 (2-pack coatings)

Metallic	6.7
Military Specification	4.5 (1-pack), 6.7 (2-pack)
Mold-Seal	43.7
Multi-Colored	25.3
Optical	74.7
Vacuum Metallizing	74.7

Table 8 - Automotive/transportation and business machine plastic parts maximum VOC emission rate limitations (VOC per volume solids)

Coating Category	Pound VOC per Gallon Solids
--Automotive/Transportation Coatings*--	
High-Bake - Interior and Exterior Parts	
Flexible Primer	11.6
Non-flexible Primer	6.7
Basecoat	10.3
Clearcoat	8.8
Non-Basecoat/Clearcoat	10.3
Low-Bake/Air Dried - Exterior Parts	
Primer	13.8
Basecoat	15.6
Clearcoat	11.6
Non-Basecoat/Clearcoat	15.6

Low-Bake/Air Dried Coatings - Interior Parts	15.6
Touch-Up and Repair Coatings	17.7
--Business Machine Coatings--	
Primer	4.8
Topcoat	4.8
Texture Coat	4.8
Fog Coat	3.1
Touch-Up and Repair	4.8

* For red, yellow, and black automotive coatings, except touch up and repair coatings, the recommended limit is determined by multiplying the appropriate limit in table 8 of this rule by 1.15.

Table 9 - Pleasure craft surface coating maximum VOC emission rate limitations (VOC per volume solids)

Coating Category	Pound VOC per Gallon Solids
Extreme High-Gloss Topcoat	9.2
High-Gloss Topcoat	6.7
Pretreatment Wash Primer	55.6
Finish Primer/Surfacer	6.7
High-Build Primer Surfacer	4.6
Aluminum Substrate Antifoulant	12.8
Other Substrate Antifoulant	4.4
All Other Pleasure Craft Surface Coatings for Metal or Plastic	6.7

(3) Option three. Reducing coating VOC emissions by add-on controls only.

An owner or operator may achieve compliance with this rule by using add-on air pollution control equipment that achieves a minimum overall VOC control efficiency of ninety per cent in lieu of the options under paragraph (C)(1) or (C)(2) of this rule. Such add-on air pollution control equipment shall meet paragraph (F) of this rule.

(D) One, or a combination, of the following application methods shall be used for coating application, except when complying using option three (add-on air pollution control equipment only) under paragraph (C)(3) of this rule or exempt under paragraph (A) (3) of this rule:

- (1) Electrostatic equipment.
- (2) High volume low pressure (HVLP) spray equipment.
- (3) Flow coating.
- (4) Roller coating.
- (5) Dip coating, including electrodeposition.
- (6) Airless spray.
- (7) Air-assisted airless spray.
- (8) Other coating application method capable of achieving a transfer efficiency equivalent or better than achieved by HVLP spraying.

(E) Work practice standards.

Work practices shall be used to minimize VOC emissions from mixing operations, storage tanks and other containers, and handling operations for coatings, thinners, cleaning materials, and waste materials. Work practices shall include, but are not limited to, the following:

- (1) Store all VOC containing coatings, thinners, coating related waste, and cleaning materials in closed containers.
- (2) Ensure that mixing and storage containers used for VOC containing coatings, thinners, coating related waste, and cleaning materials are kept closed at all times except when depositing or removing these materials.

- (3) Minimize spills of VOC containing coatings, thinners, coating related waste, and cleaning materials.
 - (4) Convey VOC containing coatings, thinners, coating related waste, and cleaning materials from one location to another in closed containers or pipes.
 - (5) Minimize VOC emissions from the cleaning of application, storage, mixing, and conveying equipment by ensuring that equipment cleaning is performed without atomizing the cleaning solvent and all spent solvent is captured in closed containers.
- (F) Compliance procedures and test methods.
- (1) Compliance with the VOC emission limitations specified in this rule are based upon a weighted average by volume of all coating materials employed in the coating line in any one day. The VOC contents and densities of the coating materials subject to this rule shall be determined in accordance with paragraph (B) of rule 3745-21-10 of the Administrative Code. The VOC emission rate, capture efficiency and control efficiency for coating lines subject to this rule shall be determined in accordance with paragraph (C) of rule 3745-21-10 of the Administrative Code.
 - (2) The averaging of VOC emissions over two or more coating lines in order to demonstrate compliance with an applicable emission limitation (i.e., cross-line averaging) is prohibited.
 - (3) If add-on air pollution control equipment is used to meet this rule, the following monitoring shall be applicable:
 - (a) The combustion temperature is monitored continuously if a thermal incinerator is operate.
 - (b) For catalytic incinerators, one of the following:
 - (i) The inlet and exhaust gas temperatures are monitored continuously.
 - (ii) The inlet temperature only for an owner or operator that elects to implement an inspection and maintenance plan for the catalytic incinerator that meets paragraph (F)(5) of this rule.
 - (c) Control device efficiency is monitored continuously if a carbon absorber or control device other than a thermal or catalytic incinerator is operated.

(4) If add-on air pollution control equipment is used to meet this rule, the following emissions testing shall be applicable:

- (a) The general provisions specified under paragraphs (A)(2) to (A)(5) of rule 3745-21-10 of the Administrative Code shall apply to compliance testing.
- (b) The test methods and procedures of paragraph (C) of rule 3745-21-10 of the Administrative Code shall be followed.

For the purpose of demonstrating compliance with the emission control requirements of paragraph (C)(2) or (C)(3) of this rule, the affected source shall be run at typical operating conditions and flow rates compatible with scheduled production during any emission testing.

(5) For an owner or operator that elects, in accordance with paragraph (F)(3)(b)(ii) of this rule, to monitor the inlet temperature only of the catalytic incinerator, an inspection and maintenance plan shall be developed, maintained on-site, and made readily available upon the request of the appropriate Ohio EPA district office or local air agency. At a minimum, the plan shall include the following:

- (a) Annual sampling and analysis of the catalyst activity (i.e., conversion efficiency) following the manufacturer's or catalyst supplier's recommended procedures.
- (b) Monthly inspection of the oxidizer system including the burner assembly and fuel supply lines for problems.
- (c) Annual internal and monthly external visual inspection of the catalyst bed to check for channeling, abrasion, and settling. If problems are found, corrective action consistent with the manufacturer's recommendations shall be implemented and a new performance test to determine destruction efficiency in accordance with paragraph (C) of rule 3745-21-10 of the Administrative Code shall be conducted.

(G) Recordkeeping and reporting.

- (1) The owner or operator of a coating line subject to this rule shall demonstrate the on-going status of compliance with the applicable VOC emission limitations or control requirements by means of one of the recordkeeping and reporting requirement alternatives specified in paragraph (B)(3) of rule 3745-21-09 of the Administrative Code.
- (2) Any owner or operator of a facility who complies with paragraph (C)(2) or (C)(3) of this rule through the use of add-on air pollution control equipment shall

record the key operating parameters for the control equipment, including but not limited to, the following information:

- (a) On a daily basis, the combustion temperature, inlet and exhaust gas temperatures and control device efficiency, as appropriate, pursuant to paragraph (F)(3) of this rule.
 - (b) Daily hours of operation.
 - (c) All maintenance performed including the date and type of maintenance.
- (3) All records made to determine compliance with this rule shall be maintained for five years from the date such record is created and shall be made available to the director or any authorized representative of the director within ninety days of a request.

(H) Compliance dates.

- (1) The owner or operator of a coating line that is subject to this rule shall comply with this rule no later than the following dates:
- (a) For any subject coating line located in Ashtabula, Cuyahoga, Geauga, Lake, Lorain, Medina, Portage, or Summit county for which installation commenced before ~~the effective date of this rule~~ October 15, 2015, the compliance date for the coating line is either ~~twelve months after the effective date of this rule~~ October 15, 2016 or the date of initial startup of the coating line, whichever is later.
 - (b) For any subject coating line located in Ashtabula, Cuyahoga, Geauga, Lake, Lorain, Medina, Portage, or Summit county for which installation commenced on or after ~~the effective date of this rule~~ October 15, 2015, the compliance date for the coating line is the initial startup date of the coating line.
 - (c) For any subject coating line located in Butler, Clermont, Hamilton or Warren county for which installation commenced before the effective date of this rule, the compliance date is either March 1, 2023 or the date of initial startup of the coating line, whichever is later.
 - (d) For any subject coating line located in Butler, Clermont, Hamilton or Warren county for which installation commenced on or after the effective date of this rule, the compliance date is the date of initial startup of the coating line.

- (2) The owner or operator of a coating line that is subject to this rule shall demonstrate compliance with paragraph (C)(2) or (C)(3) of this rule by testing the control device on each subject source in accordance with paragraph (F)(4) of this rule according to the following:
- (a) For any owner or operator of a coating line subject to paragraph (H)(1)(a) of this rule, by no later than ninety days after the process's compliance date. In addition, the Ohio EPA may accept the results of an emission test conducted prior to the effective date of this rule, if the owner or operator provides information and data to the Ohio EPA which demonstrate that the test was witnessed by the Ohio EPA or local air agency, that an approved USEPA emission test method was employed, and that the operation of the process was consistent with the current operating conditions and operating capacity.
 - (b) For any owner or operator of a coating line subject to paragraph (H)(1)(b) of this rule, within one hundred-eighty days after the coating line's compliance date.
- (3) Additional testing of a subject coating line and its VOC add-on air pollution control equipment in accordance with paragraph (F)(4) of this rule may be required by the director to ensure continued compliance.

(I) Applicability notification, compliance certification, and permit application.

- (1) The owner or operator of a coating line that is subject to this rule, is located in located in Ashtabula, Cuyahoga, Geauga, Lake, Lorain, Medina, Portage, or Summit county, and has an initial startup of the coating line before October 15, 2015 shall notify the appropriate Ohio EPA district office or local air agency in writing that the coating line is subject to this rule not later than December 14, 2015 or within sixty days after the coating line becomes subject to this rule, providing the information specified in paragraph (I)(5) of this rule.
- (2) The owner or operator of a coating line that is subject to this rule, is located in Ashtabula, Cuyahoga, Geauga, Lake, Lorain, Medina, Portage, or Summit county, and has an initial startup of the coating line on or after October 15, 2015 shall notify the appropriate Ohio EPA district office or local air agency in writing that the coating line is subject to this rule not later than either the date of initial startup of the subject coating line or December 14, 2015 (whichever is later), providing the information specified in paragraph (I)(5) of this rule. The application for a permit-to-install under rule 3745-31-02 of the Administrative Code may be used to fulfill the notification requirements of this paragraph.

- (3) The owner or operator of a coating line that is subject to this rule, is located in Butler, Clermont, Hamilton or Warren county, and has an initial startup of the coating line before the effective date of this rule shall notify the appropriate Ohio EPA district office or local air agency in writing that the coating line is subject to this rule not later than sixty days after the effective date of this rule, providing the information specified in paragraph (I)(5) of this rule.
- (4) The owner or operator of a coating line that is subject to this rule, is located in Butler, Clermont, Hamilton or Warren county, and has an initial startup of the coating line on or after the effective date of this rule shall notify the appropriate Ohio EPA district office or local air agency in writing that the coating line is subject to this rule not later than either the date of initial startup of the subject coating line or sixty days after the effective date of this rule (whichever is later), providing the information specified in paragraph (I)(5) of this rule. The application for a permit-to-install under rule 3745-31-02 of the Administrative Code may be used to fulfill the notification requirements of this paragraph.
- ~~(1)(5) The owner or operator of a coating line that is subject to this rule with an initial startup date before the effective date of this rule shall notify the Ohio EPA district office or local air agency in writing that the coating line is subject to this rule. The notification, which shall be submitted not later than sixty days after the effective date of this rule or within sixty days after the coating line becomes subject to this rule, required in paragraphs (I)(1) to (I)(4) of this rule shall provide the following information:~~
- (a) Name and address of the owner or operator.
 - (b) Address (i.e., physical location) of the facility.
 - (c) Equipment description and Ohio EPA application number (if assigned) of the subject coating line.
 - (d) Identification of the VOC emission requirement, the means of compliance, and the compliance date for the subject coating line.
 - (e) An application for an operating permit or an application for a modification to an operating permit in accordance with Chapter 3745-77 of the Administrative Code (for sources subject to the Title V permit program) or an application for a permit-to-install and operate or an application for a modification to a permit-to-install and operate in accordance with Chapter 3745-31 of the Administrative Code (for sources not subject to the Title V permit program) for each subject process that meets one of the following:

- (i) The process does not possess an effective operating permit or permit-to-install and operate.
- (ii) The process possesses an effective operating permit or permit-to-install and operate and the owner or operator cannot certify in writing to the director that such subject process is in compliance with this rule. An application for an operating permit or permit-to-install and operate is not required provided the subject process is operating under an effective permit and certifies compliance. Such certification shall include all compliance certification requirements under paragraph (I)(36) of this rule.

~~(2) The owner or operator of a coating line that is subject to this rule with an initial startup date on or after the effective date of this rule shall notify the Ohio EPA district office or local air agency in writing that the coating line is subject to this rule. The notification, which shall be submitted not later than either the date of initial startup of the subject coating line, or sixty days after the effective date of this rule (whichever is later), shall provide the information listed under paragraph (I)(1) of this rule. The application for an installation permit under rule 3745-31-02 of the Administrative Code may be used to fulfill the notification requirements of this paragraph.~~

~~(3)~~(6) Compliance certification.

- (a) The owner or operator of a coating line that is subject to this rule shall notify the Ohio EPA district office or local air agency in writing within thirty days following the completion of any of the following:
 - (i) For a coating line subject to the VOC emission requirements in paragraph (C)(1) or (C)(2) of this rule, the first documented achievement of compliance with each of the requirements.
 - (ii) For a coating line subject to the VOC add-on air pollution control equipment requirement in paragraph (C)(2) or (C)(3) of this rule:
 - (a) The completion of installation and initial use of a VOC emission control system for the subject coating line.
 - (b) The completion of installation and initial use of any monitoring devices required under paragraph (C)(2) or (C)(3) of this rule for the subject coating line.

- (c) The completion of any compliance testing conducted in accordance with paragraph (H)(2) of this rule to demonstrate compliance with the applicable control requirements.
 - (b) The compliance certification under paragraph (I)(36)(a) of this rule shall provide the following, where applicable:
 - (i) A description of the requirements.
 - (ii) A description of the VOC emission control system.
 - (iii) A description of the monitoring devices.
 - (iv) A description of the records that document continuing compliance.
 - (v) The results of any compliance tests, including documentation of test data.
 - (vi) The results of any records that document continuing compliance, including calculations.
 - (vii) A statement by the owner or operator as to whether the subject coating line has complied with the requirements.
- (J) Requirements for an owner or operator of a coating line that determines ~~they~~the owner or operator are not subject to one of the following:
 - (1) The owner or operator of a facility that determines the total actual VOC emissions, before the application of control systems and devices, from all miscellaneous metal or plastic parts coating operations, including related cleaning operations, at the facility are not equal to or greater than the limitation specified in paragraph (A)(1)(a) of this rule, shall select one of the following methods and maintain the following records for a period of five years:
 - (a) Monthly recordkeeping method, as follows:
 - (i) Total gallons of each coating and cleaning material used per calendar month.
 - (ii) VOC content (per cent by weight or pounds per gallon, whichever is consistent with the records kept in paragraph (J)(1)(a)(i) of this rule) of each coating and cleaning material used per calendar month.

- (iii) The total monthly VOC emissions, before the application of control systems and devices, in pounds for all coatings and cleaning materials employed per calendar month.
- (iv) The rolling twelve-month average of VOC emissions, in tons, before the application of control systems and devices. The rolling twelve-month average shall be calculated as the total VOC emissions, for the current calendar month, plus the total VOC emissions from the previous eleven calendar months.

(b) Daily emissions method, the following:

Provided total VOC emissions are less than 15.0 pounds per day, the owner or operator may elect to maintain the following records in lieu of the records required under paragraph (J)(1)(a) of this rule.

- (i) Total pounds or gallons of each coating and cleaning material used per day.
- (ii) VOC content (per cent by weight or pounds per gallon, whichever is consistent with the records kept in paragraph (J)(1)(b)(i) of this rule) of each coating and cleaning material used per day.
- (iii) The total daily VOC emissions, before the application of control systems and devices, in pounds for all coatings and cleaning materials employed per day.

(2) The owner or operator of a subject coating line that determines a requirement of paragraph (C) of this rule is not applicable because any individual coating category under paragraph (C) of this rule does not exceed fifty gallons per calendar year and the total usage of all such coatings does not exceed two hundred gallons per year, per facility, in accordance with paragraph (A)(3)(d)(v) of this rule shall maintain the following records, for a period of five years:

- (a) Identification of each individual coating category under paragraph (C) of this rule for which the owner or operator does not exceed fifty gallons per calendar year.
- (b) Total gallons of each coating for each individual coating category under paragraph (C) of this rule used per calendar year.
- (c) The sum of the total gallons of all such coatings identified under paragraph (J)(2)(b) of this rule used per calendar year.

- (3) The owner or operator of a subject coating line, and subject to the exemption in paragraph (A)(3)(d)(ix) of this rule, that determines a requirement of paragraph (C) of this rule is not applicable because the total usage of all HBAC containing coatings does not exceed one hundred gallons per calendar year per plastic parts coating operation, in accordance with paragraph (A)(3)(d)(ix) of this rule shall maintain the following records, for a period of five years:
- (a) Identification of each HBAC containing coating used per calendar year.
 - (b) Total gallons of each HBAC containing coating used per calendar year.
 - (c) The sum of the total gallons of all such coatings identified under paragraph (J)(3)(b) of this rule used per calendar year.
- (4) The owner or operator of a subject coating line, and subject to the exemption in paragraph (A)(3)(f)(i) of this rule, that determines a requirement of paragraph (C) of this rule is not applicable because the total usage of all coatings, except for coatings used on parts or products which are not metal, does not exceed three gallons per day, in accordance with paragraph (A)(3)(f)(i) of this rule shall maintain the records specified in paragraphs (B)(3)(d) and (B)(3)(e) of rule 3745-21-09 of the Administrative Code.

Effective: 3/27/2022
Five Year Review (FYR) Dates: 11/29/2021 and 11/29/2026

CERTIFIED ELECTRONICALLY

Certification

03/17/2022

Date

Promulgated Under: 119.03
Statutory Authority: 3704.03(E)
Rule Amplifies: 3704.03(A), 3704.03(E)
Prior Effective Dates: 10/15/2015, 02/16/2019

3745-21-27

Boat manufacturing.

[Comment: For dates and availability of non-regulatory government publications, publications of recognized organizations and associations, federal rules, and federal statutory provisions referenced in this rule, see paragraph (JJ) of rule 3745-21-01 of the Administrative Code titled to "referenced materials."]

(A) Applicability.

(1) Except as provided in paragraph (B) of this rule, paragraphs (C) to (L) of this rule shall apply to the following boat manufacturing operations at any boat manufacturing facility that meets all of the criteria under paragraph (A)(2) of this rule:

- (a) Open molding resin and gel coat operations (these include pigmented gel coat, clear gel coat, production resin, tooling gel coat, and tooling resin).
- (b) Resin and gel coat mixing operations.
- (c) Resin and gel coat application equipment cleaning operations.

The owner or operator of a boat manufacturing facility that manufactures solely fiberglass parts of boats such as hatches, seats, lockers, or boat trailers is not considered a boat manufacturing facility for the purpose of this rule.

(2) The boat manufacturing operations meet the following:

- (a) Are located at a boat manufacturing facility where the total actual VOC emissions from all boat manufacturing operations identified in paragraph (A)(1) of this rule (including, but not limited to emissions from the manufacture of hatches, seats, lockers, trailers or cleanup materials) are equal to or greater than 2.7 tons per rolling twelve-month period, before the application of control system and devices.
- (b) Are located at a boat manufacturing facility in Ashtabula, Butler, Clermont, Cuyahoga, Geauga, Hamilton, Lake, Lorain, Medina, Portage, ~~or~~ Summit or Warren county.

(B) Exemptions.

The following operations or materials are exempt from the monomer and nonmonomer VOC requirements of paragraph (D) of this rule:

- (1) Production resins (including skin coat resins) that must meet specifications for use in military vessels or must be approved by the United States coast

guard for use in the construction of lifeboats, rescue boats, and other life-saving appliances approved under 46 CFR subchapter Q or the construction of small passenger vessels regulated by 46 CFR subchapter T. Production resins for which this exemption is used shall be applied with a nonatomized resin application method.

- (2) Pigmented, clear, and tooling gel coat used for part or mold repair and touch-up. The total gel coat materials included in this exemption shall not exceed 1.0 per cent by weight of all gel coat used at the facility on a twelve-month rolling basis.
- (3) Pure, one hundred per cent vinylester resin used for skin coats. This exemption does not apply to blends of vinylester and polyester resins used for skin coats. Resins for which this exemption is used shall be applied with a nonatomized application method. The total resin materials included in the exemption cannot exceed 5.0 per cent by weight of all resin used at the facility on a twelve-month rolling basis.
- (4) Any closed molding operation that meets the specific definition of closed molding as defined in paragraph (HH) of rule 3745-21-01 of the Administrative Code. Open molding resin and gel coat operations that precede a closed molding operation are not exempt. Examples of these operations include gel coat or skin coat layers that are applied before lamination is performed by closed molding.

Any owner or operator of a facility claiming an exemption pursuant to this subparagraph shall record and maintain records, as applicable, in accordance with paragraph (M)(2) of this rule.

(C) Definitions.

The definitions applicable to this rule are contained in paragraphs (A), (B), and (HH) of rule 3745-21-01 of the Administrative Code.

(D) Molding resin and gel coat operation standards.

- (1) The owner or operator of a boat manufacturing facility shall limit monomer VOC emissions from the five operations listed below to the monomer VOC limitation specified in paragraph (D)(3) of this rule.
 - (a) Production resin.
 - (b) Pigmented gel coat.
 - (c) Clear gel coat.

(d) Tooling resin.

(e) Tooling gel coat.

(2) Non-monomer VOC content.

The owner or operator of a boat manufacturing facility shall not apply any resin or gel coat that exceeds a non-monomer content of 5.0 per cent, by weight, of resin or gel coat.

(3) Monomer VOC emission limitation.

(a) The owner or operator of a boat manufacturing facility shall limit monomer VOC emissions from open molding resin and gel coat operations to the limitation specified by the following equation, based on a twelve-month rolling average.

$$\text{Monomer VOC limit} = [92(M_R) + 318(M_{PG}) + 582(M_{CG}) + 108(M_{TR}) + 428(M_{TG})]$$

Where:

Monomer VOC limit = total allowable monomer VOC that can be emitted from the molding operations included in the average, pounds per twelve-month period.

M_R = mass of production resin used in the past twelve months, excluding any materials that are exempt pursuant to paragraph (B) of this rule, in tons.

M_{PG} = mass of pigmented gel coat used in the past twelve months, excluding any materials that are exempt pursuant to paragraph (B) of this rule, in tons.

M_{CG} = mass of clear gel coat used in the past twelve months, excluding any materials that are exempt pursuant to paragraph (B) of this rule, in tons.

M_{TR} = mass of tooling resin used in the past twelve months, excluding any materials that are exempt pursuant to paragraph (B) of this rule, in tons.

M_{TG} = mass of tooling gel coat used in the past twelve months, excluding any materials that are exempt pursuant to paragraph (B) of this rule, in tons.

The numerical coefficients associated with each term on the right hand side of the equation are the allowable monomer VOC emission rate for that particular material in units of pounds per ton of material used.

- (b) The owner or operator of a boat manufacturing facility using a filled production resin or filled tooling resin shall limit monomer VOC emissions from molding operations to the following limits:
 - (i) If the filled resin is used as a production resin; less than or equal to 92.0 pounds of monomer VOC per ton of filled resin applied.
 - (ii) If the filled resin is used as a tooling resin; less than or equal to 108.0 pounds of monomer VOC per ton of filled resin applied.

(E) Cleaning material standards.

- (1) The VOC content of cleaning solvents employed for routine application equipment cleaning shall contain a maximum of 5.0 per cent VOC, by weight, or have a composite partial vapor pressure of no more than 0.50 mmHg at sixty-eight degrees Fahrenheit.
- (2) Only non-VOC solvents shall be used to remove cured resin and gel coat from application equipment.

(F) Application technique standards.

- (1) Production resins exempt pursuant to paragraph (B)(1) of this rule shall be applied with a nonatomized application method.
- (2) Pure one hundred per cent vinyl ester used for skin coats exempt pursuant to paragraph (B)(3) of this rule shall be applied with a nonatomized application method.

(G) Work practice standards.

All resin and gel coat mixing containers with a capacity equal to or greater than 55.0 gallons, including those used for on-site mixing of putties and polyputties, have a cover with no visible gaps in place at all times. This work practice standard does not apply when material is being manually added to or removed from a container, or when mixing or pumping equipment is being placed in or removed from a container.

(H) Compliance procedures and test methods.

- (1) Non-monomer VOC content requirement of paragraph (D)(2) of this rule.

Compliance with the non-monomer VOC content (weight per cent) for resin and gel coat materials shall be determined by using test methods and procedures specified in paragraph (B) of rule 3745-21-10 of the Administrative Code.

- (2) The monomer VOC emission limitation requirement of paragraph (D)(3) of this rule.

Compliance with the monomer VOC emission limitation for resin and gel coat operations shall be determined using one of the following options:

- (a) Compliant material option.

- (i) The owner or operator shall demonstrate compliance by using resins and gel coats that meet the monomer VOC content requirements in table 1 of this rule.

Table 1 Alternative VOC content requirements for molding resin and gel coat operations

Operation	Application Method	Weighted-Average Monomer VOC Content (weight per cent)
Production resin	Atomized	28.0
Production resin	Nonatomized	35.0
Pigmented gel coat	Any method	33.0
Clear gel coat	Any method	48.0
Tooling resin	Atomized	30.0
Tooling resin	Nonatomized	39.0
Tooling gel coat	Any method	40.0

- (ii) The monomer VOC content (weight per cent) shall be determined by using SCAQMD method 312-91. As an alternative, manufacture's formulation data may be used to demonstrate compliance. If there is a discrepancy between the manufacture's formulation data and the results of a subsequent test, test method results will be the determining factor unless the owner or operator can demonstrate to the director that the manufacturer's formulation data are correct.

- (iii) Compliance using the VOC content requirements listed in table 1 of this rule is based on a twelve-month rolling average that is calculated at the end of every month. The first twelve-month rolling-average period begins on the compliance date specified in paragraph (K)(1) of this rule. If the owner or operator is using filled material (production resin or tooling resin), the owner or operator shall comply according to the procedure described in paragraph (H)(3) of this rule.
- (iv) At the end of the twelfth month after the facility's compliance date and at the end of every subsequent month, the owner or operator shall review the VOC contents of the resins and gel coats used in the past twelve months in each operation. If all resins and gel coats used in an operation have VOC contents no greater than the applicable VOC content limitations in table 1 of this rule, then the owner or operator is in compliance with the emission limitation specified in paragraph (D)(3) of this rule for that twelve-month period for that operation. In addition, the owner or operator does not need to complete the weighted-average VOC content calculation contained in paragraph (H)(2)(a)(v) of this rule for that operation.
- (v) In the event the owner or operator does not demonstrate compliance under paragraph (H)(2)(a)(iv) of this rule, at the end of every month, the owner or operator shall use the following equation to calculate the weighted average VOC content for all resins and gel coats used in each operation in the past twelve months.

$$\text{Weighted Average VOC Content (\%)} = \frac{\sum_{i=1}^n (M_i \text{ VOC}_i)}{\sum_{i=1}^n (M_i)}$$

Where:

M_i = mass of molding resin or gel coat "i" used in the past twelve months in an operation, tons.

VOC_i = Monomer VOC content, by weight percent, of molding resin or gel coat "i" used in the past twelve months in an operation.

n = number of different molding resins or gel coats used in the past twelve months in an operation.

If the weighted-average VOC content for all materials of a certain type and specific application method does not exceed the applicable VOC content limitation specified in table 1 of this rule, then the owner or operator is in compliance with the emission limitation specified in paragraph (D)(3) of this rule.

(b) Emissions averaging option.

- (i) Compliance using the emissions averaging option is demonstrated on a twelve-month rolling-average basis and is determined at the end of every month (twelve times per year). The first twelve-month rolling-average period begins on the compliance date specified in paragraph (K)(1) of this rule.
- (ii) At the end of the twelfth month after the facility's compliance date and at the end of every subsequent month, use the following equation to demonstrate that the VOC emissions from those operations included in the average do not exceed the emission limitation in paragraph (D)(3) of this rule calculated for the same twelve-month period. (Include terms in the equation specified in paragraph (D)(3) of this rule and the following equation for only those operations and materials included in the average.)

$$\text{Monomer VOC emissions} = (PV_R)(M_R) + (PV_{PG})(M_{PG}) + (PV_{CG})(M_{CG}) + (PV_{TR})(M_{TR}) + (PV_{TG})(M_{TG})$$

Where:

Monomer VOC emissions = Monomer VOC emissions calculated using the monomer VOC emission equations for each operation included in the average, in pounds.

PV_R = Weighted-average monomer VOC emission rate for production resin used in the past twelve months, in pounds per ton.

M_R = Mass of production resin used in the past twelve months, in tons.

PV_{PG} = Weighted-average monomer VOC emission rate for pigmented gel coat used in the past twelve months, in pounds per ton.

M_{PG} = Mass of pigmented gel coat used in the past twelve months, in tons.

PV_{CG} = Weighted-average monomer VOC emission rate for clear gel coat used in the past twelve months, in pounds per ton.

M_{CG} = Mass of clear gel coat used in the past twelve months, in pounds.

PV_{TR} = Weighted-average monomer VOC emission rate for tooling resin used in the past twelve months, in pounds per ton.

M_{TR} = Mass of tooling resin used in the past twelve months, in tons.

PV_{TG} = Weighted-average monomer VOC emission rate for tooling gel coat used in the past twelve months, in pounds per ton.

M_{TG} = Mass of tooling gel coat used in the past twelve months, in tons.

- (iii) At the end of every month, use the following equation to compute the weighted-average monomer VOC emission rate for each molding resin and gel coat operation included in the average.

$$PV_{op} = \frac{\sum_{i=1}^n M_i PV_i}{\sum_{i=1}^n M_i}$$

Where:

PV_{OP} = weighted-average monomer VOC emission rate for each molding operation (PV_R , PV_{PG} , PV_{CG} , PV_{TR} , and PV_{TG}) included in the average, pounds of monomer VOC per ton of material applied.

M_i = mass of resin or gel coat "i" used within an operation in the past twelve months, in tons.

n = number of different molding resins and gel coats used within an operation in the past twelve months.

PV_i = the monomer VOC emission rate for resin or gel coat "i" used within an operation in the past twelve months, pounds of monomer VOC per tons of material applied. PV_i shall equal PV_F as calculated under paragraph (H)(3) of this rule when using filled resins.

- (iv) The owner or operator shall use the equations in table 2 of this rule to calculate the monomer VOC emission rate (PV_i) for each resin and gel coat used in each operation in the past twelve months.

Table 2 Monomer VOC emission rate formulas for molding operations.

Operation	Application Method	Formula to calculate the monomer VOC emission rate.
Production resin, tooling resin	Atomized	$0.014 \times (\text{Resin VOC per cent})^{2.425}$
	Atomized, plus vacuum bagging with roll-out	$0.01185 \times (\text{Resin VOC per cent})^{2.425}$
	Atomized, plus vacuum bagging without roll-out	$0.00945 \times (\text{Resin VOC per cent})^{2.425}$
	Nonatomized	$0.014 \times (\text{Resin VOC per cent})^{2.275}$
	Nonatomized, plus vacuum bagging with roll-out	$0.0110 \times (\text{Resin VOC per cent})^{2.275}$
	Nonatomized, plus vacuum bagging without roll-out	$0.0076 \times (\text{Resin VOC per cent})^{2.275}$
Pigmented gel coat, clear gel coat, tooling gel coat	All methods	$0.445 \times (\text{Gel coat VOC per cent})^{1.675}$

Equations in table 2 of this rule calculate the monomer VOC emission rate value in kilograms of VOC per megagrams of resin or gel coat applied. To convert the monomer VOC emission rate to pounds per ton multiply the product of the equation by two. The equations for vacuum bagging with roll-out are applicable when a facility rolls out the applied resin and fabric prior to applying the vacuum bagging materials. The equations for vacuum bagging without roll-out are applicable when a facility applies the vacuum bagging materials immediately after resin application without rolling out the resin and fabric. VOC per cent equals VOC content as supplied, expressed as a weight-per cent value between zero and one hundred per cent.

- (v) If the monomer VOC emissions, as calculated in paragraph (H)(2)(b)(ii) of this rule, are less than the monomer VOC emission limitation calculated in the equation specified in paragraph (D)(3)(a) of this rule for the same twelve-month period, then the facility is in compliance with the emission limitation calculated in paragraph (D)(3)(a) of this rule for those operations and materials included in the average.
- (vi) Those operations and materials not included in this emissions average option shall demonstrate compliance using an option in paragraph (H)(2)(a) or (H)(2)(c) of this rule.

(c) Add-on control option.

- (i) The owner or operator shall demonstrate compliance by employing an add-on control device with a minimum overall control efficiency that will meet the monomer VOC emission limitations specified in paragraph (D)(3) of this rule.
- (ii) Compliance shall be determined by performing emissions tests in accordance with the following:
 - (a) The general provisions specified under paragraphs (A)(2) to (A)(5) of rule 3745-21-10 of the Administrative Code shall apply to the compliance testing.
 - (b) The test methods and procedures of paragraph (C) of rule 3745-21-10 of the Administrative Code shall be followed.

(c) When calculating the monomer VOC emission limitation in paragraph (D)(3) of this rule, the owner or operator shall use the mass of each material used during the control device performance test (in lieu of the mass of each material used over the past twelve months) to determine the emission limit that is applicable during the test. If the measured emissions at the outlet of the control device are less than the emission limit, then the facility will be considered to have achieved compliance with the emission limit.

(3) The monomer VOC emission limitation (for filled resins) requirement of paragraph (D)(3)(b) of this rule.

(a) If the owner or operator is using a filled production resin or filled tooling resin, compliance shall be demonstrated for the filled material on an as-applied basis using the following equation:

$$PV_F = (PV_U)(100 - \text{per cent filler}) / 100$$

Where:

PV_F = The as-applied monomer VOC emission rate for a filled production resin or tooling resin, pounds of monomer VOC per ton of filled material.

PV_U = The monomer VOC emission rate for the neat (unfilled) resin, before filler is added, as calculated using the formulas in table 2 of this rule.

Per cent filler = The weight-per cent of filler in the as-applied filled resin system.

(b) If the owner or operator is including a filled resin in the emissions averaging procedure described in paragraph (H)(2)(b) of this rule, then the owner or operator shall use the value of PV_F calculated using the equation above for the value of PV_i in equation specified in paragraph (H)(2)(b)(iii) of this rule.

(4) The cleaning material requirements of paragraph (E) of this rule.

(a) Compliance with the VOC content requirement shall be determined by using the procedures outlined in USEPA method 24.

(b) Compliance with the vapor pressure requirement shall be determined by the following procedures:

- (i) Determining the identity and quantity of each compound in a blended organic solvent by using ASTM D2306-00, or by using ASTM E260-96(2011) for organics and ASTM D3792-05(2009) for water content, if applicable, or the manufacturer's product formulation data; and
- (ii) Determining the vapor pressure of each pure VOC component by using ASTM D2879-10 or from publications such as "Perry's Chemical Engineer's Handbook", "CRC Handbook of Chemistry and Physics", or "Lange's Handbook of Chemistry"; and
- (iii) Calculating the composite partial pressure of the solvent by using the formula for composite partial pressure. For the purpose of this calculation, the blended solvent shall be assumed to be an ideal solution where "Raoult's Law" applies. The partial pressures of each compound at twenty degrees Celsius (sixty-eight degrees Fahrenheit) shall be used in the formula.

The VOC composite partial vapor pressure is calculated as follows:

$$PP_c = \sum_{i=1}^n \frac{(W_i)(VP_i) / MW_i}{\frac{W_w}{MW_w} + \frac{W_e}{MW_e} + \sum_{i=1}^n \frac{W_i}{MW_i}}$$

Where:

W_i = Weight of the "i"th VOC compound, in grams.

W_w = Weight of water, in grams.

W_e = Weight of exempt compound, in grams.

MW_i = Molecular weight of the "i"th VOC compound, in grams per gram-mole.

MW_w = Molecular weight of water, in grams per gram-mole.

MW_e = Molecular weight of the "e"th exempt compound, in grams per gram-mole.

PP_c = VOC composite partial pressure at twenty degrees Celsius (sixty-eight degrees Fahrenheit), in mmHg.

VP_i = Vapor pressure of the "i"th VOC compound at twenty degrees Celsius (sixty-eight degrees Fahrenheit), in mmHg.

(I) Monitoring and recordkeeping.

- (1) The owner or operator of a boat manufacturing facility that is subject to the provisions of this rule shall collect and record the following information for each operation subject to this rule on a monthly basis and shall maintain the information at the facility for a period of five years:
 - (a) The total amounts, in pounds, of atomized molding production resin, nonatomized production resin, pigmented gel coat, clear gel coat, atomized tooling resin, nonatomized tooling resin, and tooling gel coat used per month and the weighted-average VOC contents for each operation, expressed as weight per cent.
 - (b) All calculations performed pursuant to paragraph (H) of this rule.
 - (c) The VOC content of each non-monomer resin and gel coat employed.
 - (d) For each cleaning material employed for routine application equipment cleaning, either the VOC content, by weight per cent or the composite vapor pressure, in mmHg; whichever is the applicable requirement selected to comply with the cleaning solvent requirements of paragraph (E) of this rule.
 - (e) Calculations performed to establish the monomer VOC emission limitation as specified in paragraph (D)(3)(a) of this rule.
- (2) If an owner or operator of a boat manufacturing facility that employs add-on control equipment pursuant to paragraph (H)(2)(c) of this rule consisting of a thermal incinerator or catalytic incinerator to achieve and maintain compliance, the owner or operator shall comply with the following:

- (a) Continuous temperature monitoring and continuous temperature recording equipment shall be installed and operated to accurately measure the operating temperature for the control device.
 - (b) The following information shall be collected and recorded for each day of operation of the control device, and the information shall be maintained at the facility for a period of five years:
 - (i) A log or record of the operating time for the control device, monitoring equipment, and the associated boat manufacturing operation.
 - (ii) For thermal incinerators, all three-hour periods of operation during which the average combustion temperature was more than fifty degrees Fahrenheit below the average combustion temperature during the most recent emission test that demonstrated that the boat manufacturing facility was in compliance.
 - (iii) For catalytic incinerators, all three-hour periods of operation during which the average temperature of the dryer exhaust gases immediately before the catalyst bed was more than fifty degrees Fahrenheit below the average temperature of the dryer exhaust gases during the most recent emission test that demonstrated that the boat manufacturing facility was in compliance, and one of the following:
 - (a) All three-hour periods during which the average temperature difference across the catalyst bed was less than eighty per cent of the average temperature difference during the most recent emission test that demonstrated that the boat manufacturing facility was in compliance.
 - (b) Records required by an inspection and maintenance plan for the catalytic incinerator that meets paragraph (I)(4) of this rule.
- (3) If an owner or operator of a boat manufacturing facility operates add-on control equipment pursuant to paragraph (H)(2)(c) of this rule consisting of a carbon adsorption system to achieve and maintain compliance, the owner or operator shall comply with the following:
- (a) One of the following types of monitoring and recording equipment shall be installed and operated for the carbon adsorption system:
 - (i) A continuous emission monitoring and recording system that is capable of accurately measuring and recording the concentration of

organic compounds in the exhaust gases from the carbon adsorption system.

- (ii) Monitoring and recording equipment that are capable of accurately measuring and recording the total mass steam flow rate for each regeneration cycle of each carbon bed.
 - (iii) Monitoring and recording equipment that are capable of accurately measuring and recording the temperature of each carbon bed after regeneration (and after completion of any cooling cycle).
- (b) The following information shall be collected and recorded for each day of operation of the carbon adsorption system, and the information shall be maintained at the facility for a period of five years:
- (i) A log or record of the operating time for the carbon adsorption system, monitoring equipment, and the associated boat manufacturing operation.
 - (ii) For a carbon adsorption system that employs a continuous emission monitoring and recording system to measure and record the concentration of organic compounds in the exhaust gases, all three-hour periods of operation during which the average concentration level or reading in the exhaust gases is more than twenty per cent greater than the exhaust gas organic compound concentration level or reading measured by the most recent performance test that demonstrated that the boat manufacturing facility was in compliance.
 - (iii) For a carbon adsorption system that employs monitoring and recording equipment to measure and record the total mass steam flow rate for each regeneration cycle of each carbon bed, all carbon bed regeneration cycles during which the total mass steam flow rate was more than ten per cent below the total mass steam flow rate during the most recent performance test that demonstrated that the boat manufacturing facility was in compliance.
 - (iv) For a carbon adsorption system that employs monitoring and recording equipment to measure and record the temperature of each carbon bed after regeneration (and after completion of any cooling cycle), all carbon bed regeneration cycles during which the temperature of the carbon bed after regeneration (and after completion of any cooling cycle) was more than ten per cent

greater than the carbon bed temperature during the most recent performance test that demonstrated that the boat manufacturing facility was in compliance.

- (4) For an owner or operator that elects to monitor the dryer exhaust gases immediately before the catalyst bed of the catalytic incinerator only, in accordance with paragraph (I)(2)(b)(iii)(b) of this rule, an inspection and maintenance plan shall be developed, maintained on-site, and made readily available upon the request of the appropriate Ohio EPA district office or local air agency. At a minimum, the plan shall include the following:
 - (a) Annual sampling and analysis of the catalyst activity (i.e., conversion efficiency) following the manufacturer's or catalyst supplier's recommended procedures.
 - (b) Monthly inspection of the oxidizer system including the burner assembly and fuel supply lines for problems.
 - (c) Annual internal and monthly external visual inspection of the catalyst bed to check for channeling, abrasion, and settling. If problems are found, corrective action consistent with the manufacturer's recommendations shall be implemented and a new performance test to determine destruction efficiency in accordance with paragraph (C) of rule 3745-21-10 of the Administrative Code shall be conducted.
 - (d) Records, and a description of the results of each inspection and catalyst activity analysis.

(J) Reporting.

- (1) Any owner or operator of a boat manufacturing facility that is subject to the provisions of this rule shall notify the director of any record maintained in accordance with paragraph (I)(1) of this rule showing the use of noncomplying materials. A copy of such record shall be sent to the director within thirty days following the end of the month in which the use of noncomplying materials occurs.
- (2) Any owner or operator of a boat manufacturing facility that employs control equipment pursuant to paragraph (H)(2)(c) of this rule shall submit to the director quarterly summaries of the records required by paragraphs (I)(2)(b) and (I)(3)(b) of this rule. These quarterly reports shall be submitted no later than April thirtieth, July thirty-first, October thirty-first, and January thirty-first, and shall cover the records for the previous calendar quarters.

(K) Compliance dates.

- (1) The owner or operator of a facility that is subject to this rule shall comply with this rule no later than the following dates:
 - (a) For any subject boat manufacturing facility located in Ashtabula, Cuyahoga, Geauga, Lake, Lorain, Medina, Portage, or Summit county for which installation commenced before May 12, 2011, the compliance date for the boat manufacturing facility is either May 12, 2012 or the date of initial startup of the boat manufacturing facility, whichever is later.
 - (b) For any subject boat manufacturing facility located in Ashtabula, Cuyahoga, Geauga, Lake, Lorain, Medina, Portage, or Summit county for which installation commenced on or after May 12, 2011, the compliance date for the boat manufacturing facility is the initial startup date of the boat manufacturing facility.
 - (c) For any subject boat manufacturing facility located in Butler, Clermont, Hamilton or Warren county for which installation commenced before the effective date of this rule, the compliance date is either March 1, 2023 or the date of initial startup of the boat manufacturing facility, whichever is later.
 - (d) For any subject boat manufacturing facility located in Butler, Clermont, Hamilton or Warren county for which installation commenced on or after the effective date of this rule, the compliance date is the date of initial startup of the the boat manufacturing facility.
- (2) If an owner or operator of a boat manufacturing facility that is subject to this rule and employs add-on control equipment to comply with this rule, pursuant to paragraph (H)(2)(c) of this rule, the owner or operator shall demonstrate compliance with paragraph (H)(2)(c) of this rule by testing the VOC emission control equipment in accordance with paragraph (H)(2)(c)(ii) of this rule according to the following:
 - (a) For any owner or operator of a facility subject to paragraph (K)(1)(a) of this rule, by no later than ninety days after the operation's compliance date. In addition, the Ohio EPA may accept the results of an emission test conducted prior to May 12, 2011, if the owner or operator provides information and data to the Ohio EPA which demonstrate that the test was witnessed by the Ohio EPA or local air agency, that an approved USEPA emission test method was employed, and that the operation of

the operation was consistent with the current operating conditions and operating capacity.

(b) For any owner or operator of a facility subject to paragraph (K)(1)(b) of this rule, within one hundred eighty days after the facility's compliance date.

(3) Additional testing of the VOC emission control equipment for a boat manufacturing facility in accordance with paragraph (H)(2)(c) of this rule may be required by the director to ensure continued compliance.

(L) Applicability notification, compliance certification, and permit application.

(1) The owner or operator of a boat manufacturing facility that is subject to this rule, is located in located in Ashtabula, Cuyahoga, Geauga, Lake, Lorain, Medina, Portage, or Summit county, and has an initial startup before May 12, 2011 shall notify the appropriate Ohio EPA district office or local air agency in writing that the boat manufacturing facility is subject to this rule not later than July 11, 2011 or within sixty days after the boat manufacturing facility becomes subject to this rule, providing the information specified in paragraph (L)(5) of this rule.

(2) The owner or operator of a boat manufacturing facility that is subject to this rule, is located in Ashtabula, Cuyahoga, Geauga, Lake, Lorain, Medina, Portage, or Summit county, and has an initial startup on or after May 12, 2011 shall notify the appropriate Ohio EPA district office or local air agency in writing that the boat manufacturing facility is subject to this rule not later than either the date of initial startup of the boat manufacturing facility or July 11, 2011 (whichever is later), providing the information specified in paragraph (L)(5) of this rule. The application for a permit-to-install under rule 3745-31-02 of the Administrative Code may be used to fulfill the notification requirements of this paragraph.

(3) The owner or operator of a boat manufacturing facility that is subject to this rule, is located in Butler, Clermont, Hamilton or Warren county, and has an initial startup before the effective date of this rule shall notify the appropriate Ohio EPA district office or local air agency in writing that the boat manufacturing facility is subject to this rule not later than sixty days after the effective date of this rule, providing the information specified in paragraph (L)(5) of this rule.

(4) The owner or operator of a boat manufacturing facility that is subject to this rule, is located in Butler, Clermont, Hamilton or Warren county, and has an initial startup on or after the effective date of this rule shall notify the appropriate Ohio EPA district office or local air agency in writing that the boat manufacturing facility is subject to this rule not later than either the date of initial startup of the boat manufacturing facility or sixty days after the effective date of this rule

(whichever is later), providing the information specified in paragraph (L)(5) of this rule. The application for a permit-to-install under rule 3745-31-02 of the Administrative Code may be used to fulfill the notification requirements of this paragraph.

~~(1)(5) The owner or operator of a boat manufacturing facility that is subject to this rule with an initial startup date before May 12, 2011 shall notify the Ohio EPA district office or local air agency in writing that the boat manufacturing facility is subject to this rule. The notification, which shall be submitted not later than July 11, 2011 or within sixty days after the boat manufacturing facility becomes subject to this rule, required in paragraphs (L)(1) to (L)(4) of this rule shall provide the following information:~~

- (a) Name and address of the owner or operator.
- (b) Address (i.e., physical location) of the affected facility.
- (c) Description of the boat manufacturing facility and Ohio EPA emissions unit number, if assigned.
- (d) Identification of the VOC emission requirement, the means of compliance and the compliance date for the boat manufacturing facility.
- (e) An application for an operating permit or an application for a modification to an operating permit in accordance with Chapter 3745-77 of the Administrative Code (for sources subject to the Title V permit program) or an application for a permit-to-install and operate or an application for a modification to a permit-to-install and operate in accordance with Chapter 3745-31 of the Administrative Code (for sources not subject to the Title V permit program) for each subject process that meets one of the following:
 - (i) The process does not possess an effective operating permit or permit-to-install and operate.
 - (ii) The process possesses an effective operating permit or permit-to-install and operate and the owner or operator cannot certify in writing to the director that such subject operation is in compliance with this rule. An application for an operating permit or permit-to-install and operate is not required provided the subject process is operating under an effective permit and certifies compliance. Such certification shall include all compliance certification requirements under paragraph (L)(36) of this rule.

~~(2) The owner or operator of a boat manufacturing facility that is subject to this rule with an initial startup date on or after May 12, 2011 notify the Ohio EPA district office or local air agency in writing that the boat manufacturing facility is subject to this rule. The notification, which shall be submitted not later than either the date of initial startup of the boat manufacturing facility or July 11, 2011, whichever is later, and shall provide the information listed under paragraph (L)(1) of this rule. The application for an installation permit under rule 3745-31-02 of the Administrative Code may be used to fulfill the notification requirements of this paragraph.~~

~~(3)~~(6) Compliance certification.

- (a) The owner or operator of a fiberglass boat manufacturing facility that is subject to this rule shall notify the Ohio EPA district office or local air agency in writing within thirty days following the completion of any of the following:
 - (i) For a boat manufacturing facility subject to the VOC emission requirements in paragraph (D) of this rule, the first documented achievement of compliance with the requirements.
 - (ii) For a boat manufacturing facility subject to the add-on control requirement in paragraph (H)(2)(c) of this rule:
 - (a) The completion of installation and initial use of the add-on control system.
 - (b) The completion of installation and initial use of any monitoring devices required under paragraph (I) of this rule.
 - (c) The completion of any compliance testing conducted in accordance with paragraph (K)(2) of this rule to demonstrate compliance with the applicable control requirement.
- (b) The compliance certification under paragraph (L)~~(36)~~(a) of this rule shall provide the following, where applicable:
 - (i) A description of the requirements.
 - (ii) A description of the VOC emission control system.
 - (iii) A description of the monitoring devices.
 - (iv) A description of the records that document continuing compliance.

- (v) The results of any compliance tests, including documentation of test data.
- (vi) The results of any records that document continuing compliance, including calculations.
- (vii) A statement by the owner or operator of the affected facility as to whether the boat manufacturing facility has complied with the requirements.

(M) Requirements for an owner or operator of a boat manufacturing facility that determines they are not subject to one of the following:

(1) The owner or operator of a boat manufacturing facility that determines the total actual VOC emissions, before the application of control systems and devices, from all boat manufacturing operations are not equal to or greater than the limitation specified in paragraph (A)(2)(a) of this rule, shall select one of the following methods and maintain the following records for a period of five years:

(a) Monthly recordkeeping method, as follows:

- (i) Total pounds of all resins and gel coats used per calendar month.
- (ii) Total gallons of all cleanup materials used per calendar month.
- (iii) VOC content of each resin, gel coat, and cleanup material used per calendar month.
- (iv) The total VOC emissions before the application of control systems and devices, in pounds for all resins, gel coats, and cleanup material employed per calendar month.
- (v) The rolling twelve-month summation of VOC emissions, in tons, before the application of control systems and devices. The rolling twelve-month summation shall be calculated as the total VOC emissions for the current calendar month, plus the total VOC emissions from the previous eleven calendar months.

(b) Daily emissions method.

Provided total VOC emissions are less than 15.0 pounds per day, the owner or operator may elect to maintain the following records in lieu of the records required under paragraph (M)(1)(a) of this rule:

- (i) Total pounds of all resins and gel coats used per day.
 - (ii) Total gallons of all cleanup materials used per day.
 - (iii) VOC content of each resin, gel coat, and cleanup material used per day.
 - (iv) The total VOC emissions before the application of control systems and devices, in pounds for all resins, gel coats, and cleanup material employed per day.
- (2) The owner or operator of a boat manufacturing facility that determines the boat manufacturing operations are not subject to the monomer and non-monomer VOC requirements of paragraph (D) of this rule shall maintain the following records for a period of five years, as applicable:
- (a) For a production resin employed meeting the exemption requirements specified in paragraph (B)(1) of this rule, the owner or operator shall keep a record of the resins which are being used for this exemption.
 - (b) For a pigmented, clear, and tooling gel coat employed meeting the exemption requirements specified in paragraph (B)(2) of this rule, the amount of each of these types of coats employed and copies of calculations showing that the exempt amount does not exceed 1.0 per cent of all gel coat used.
 - (c) For a pure one hundred per cent vinylester used for skin coats meeting the exemption requirements specified in paragraph (B)(3) of this rule, the amount of one hundred per cent vinylester skin coat employed and copies of calculations showing that the exempt amount does not exceed 5.0 per cent of all resin used.

Effective: 3/27/2022
Five Year Review (FYR) Dates: 11/29/2021 and 11/29/2026

CERTIFIED ELECTRONICALLY

Certification

03/17/2022

Date

Promulgated Under: 119.03
Statutory Authority: 3704.03(E)
Rule Amplifies: 3704.03(A), 3704.03(E)
Prior Effective Dates: 05/12/2011, 10/15/2015

3745-21-28

Miscellaneous industrial adhesives and sealants.

[Comment: For dates and availability of non-regulatory government publications, publications of recognized organizations and associations, federal rules, and federal statutory provisions referenced in this rule, see paragraph (JJ) of rule 3745-21-01 of the Administrative Code titled "referenced materials."]

(A) Applicability.

(1) Except as provided in paragraph (A)(2) of this rule, paragraphs (B) to (G) of this rule shall apply to each miscellaneous industrial adhesive and sealant application process that meet the following:

- (a) The total actual VOC emissions from all miscellaneous industrial adhesive and sealant application processes (including emissions from surface preparation and cleanup activities) at the facility are equal to or greater than 3.0 tons per twelve-month rolling period before the application of control systems and devices.
- (b) The miscellaneous industrial adhesive and sealant application process is located at a facility in Ashtabula, Butler, Clermont, Cuyahoga, Geauga, Hamilton, Lake, Lorain, Medina, Portage, ~~or~~ Summit, or Warren county.

(2) Paragraphs (C)(1), (D) and (E) of this rule shall not apply to the following:

- (a) Adhesives, sealants, adhesive primers or sealant primers being tested or evaluated in any research and development, quality assurance or analytical laboratory.
- (b) Adhesives, sealants, adhesive primers or sealant primers used in the assembly, repair and manufacture of aerospace or undersea-based weapon systems.
- (c) Adhesives, sealants, adhesive primers or sealant primers used in the manufacturing of medical equipment.
- (d) Aerosol adhesive and aerosol adhesive primer application processes.
- (e) Cyanoacrylate adhesives.
- (f) Processes using adhesives, sealants, adhesive primers or sealant primers that are supplied by the manufacturer in containers with a net volume of sixteen fluid ounces or less, or a net weight of one pound or less. Any owner or operator of a facility claiming exemption pursuant to

this subparagraph shall record and maintain records in accordance with paragraph (H)(2) of this rule.

- (g) Processes using polyester bonding putties to assemble fiberglass parts at fiberglass boat manufacturing facilities and at other reinforced plastic composite manufacturing facilities.
 - (h) Digital printing operations.
- (3) Paragraphs (B) to (H) of this rule shall not apply to miscellaneous industrial adhesive and sealant application processes for which the owner or operator is required to comply with the following ~~rules~~:
- (a) Rule 3745-21-19 of the Administrative Code for aerospace.
 - (b) Paragraph (I)(4) of rule 3745-21-09 of the Administrative Code for metal furniture.
 - (c) Paragraph (K)(6) of rule 3745-21-09 of the Administrative Code for large appliances.
 - (d) Rule 3745-21-24 of the Administrative Code for flatwood paneling.
 - (e) Paragraph (F)(2) of rule 3745-21-09 of the Administrative Code for paper, film, and foil.
 - (f) Rule 3745-21-22 of the Administrative Code for offset lithographic printing and letterpress printing facilities.
 - (g) Paragraph (Y)(4) of rule 3745-21-09 of the Administrative Code for flexographic, packaging rotogravure and publication rotogravure printing lines.
 - (h) Paragraph (E) of rule 3745-21-09 of the Administrative Code for coil coatings.
 - (i) Paragraph (G) of rule 3745-21-09 of the Administrative Code for fabric coatings.
 - (j) Paragraph (X) of rule 3745-21-09 of the Administrative Code for rubber tire manufacturing.

(k) Rule 3745-21-25 of the Administrative Code for Control of Volatile Organic Compound Emissions from Reinforced Plastic Composites Production Operations.

(l) Rule 3745-21-29 of the Administrative Code for Control of Volatile Organic Compound Emissions from Automobile and Light-duty Truck Assembly Coating Operations, Heavier Vehicle Assembly Coating Operations and Cleaning Operations Associated with These Coating Operations.

(B) The definitions applicable to this rule are contained in paragraphs (A), (B), and (II) of rule 3745-21-01 of the Administrative Code.

(C) VOC limitation standards.

(1) The VOC content limitations in table 1 of this rule for adhesives, sealants, adhesive primers or sealant primers applied to particular substrates shall apply as follows:

(a) If an owner or operator uses an adhesive, sealant, adhesive primer or sealant primer subject to a specific VOC content limit in table 1 of this rule, such specific limitation is applicable rather than an adhesive-to-substrate limitation as presented in table 1 of this rule.

(b) If an adhesive is used to bond dissimilar substrates together, the applicable substrate category with the highest VOC content shall be the limitation for such use.

(c) All adhesives, sealants, adhesive primers or sealant primers shall be applied using one of the following application methods: electrostatic spray, HVLP spray, flow coat, roll coat, dip coat (including electrodeposition), airless spray, or air-assisted airless spray. An equivalent coating application method capable of achieving similar transfer efficiencies to HVLP may be approved by the director on a case-by-case basis.

Table 1 - VOC content limitations for adhesives, adhesive primers, sealants and sealant primers.

Adhesive, sealant, adhesive primer or sealant primer category	VOC content limitation (pounds per gallon, excluding water and exempt solvents)
ABS welding	3.3
Ceramic tile installation	1.1

Computer diskette jacket manufacturing	7.1
Contact bond	2.1
Cove base installation	1.3
CPVC welding	4.1
Indoor floor covering installation	1.3
Metal to urethane/rubber molding or casting	7.1
Motor vehicle adhesive	2.1
Motor vehicle weatherstrip adhesive	6.3
Multipurpose construction	1.7
Non-membrane roof installation/repair	2.6
Other plastic cement welding	4.3
Outdoor floor covering installation	2.1
PVC welding	4.3
Single-ply roof membrane installation/ repair	2.1
Structural glazing	0.8
Thin metal laminating	6.5
Tire repair	0.8
Perimeter bonded sheet vinyl flooring installation	5.5
Waterproof resorcinol glue	1.4
Sheet-applied rubber installation	7.1
Sealants:	
Architectural	2.1

Marine deck	6.4
Non-membrane roof installation/repair	2.6
Roadway	2.1
Single-ply roof membrane	3.8
Other	3.6
Adhesive primers:	
Automotive glass	7.5
Plastic cement welding	5.4
Single-ply roof membrane	2.1
Traffic marking tape	1.3
Other	2.1
Sealant primers:	
Non-porous architectural	2.1
Porous architectural	6.5
Marine deck	6.4
Other	6.3
Adhesives applied to the listed substrate (Adhesive-to-substrate limitations):	
Flexible vinyl	2.1
Fiberglass	1.7
Metal	0.3
Porous material (except wood)	1.0
Wood	0.3
Rubber	2.1

Other substrates	2.1
------------------	-----

- (2) An owner or operator of each miscellaneous industrial adhesive and sealant application process using an adhesive, sealant, adhesive primer or sealant primer subject to paragraph (C)(1) of this rule may use add-on air pollution control equipment, in lieu of complying with the VOC content limitations of table 1 of this rule, if such equipment meets the following:
- (a) The VOC emissions from the use of all adhesives, sealants, adhesive primers or sealant primers subject to this rule are reduced by an overall capture and control efficiency of at least eighty-five per cent, by weight.
 - (b) The combustion temperature is monitored continuously if a thermal incinerator is operated.
 - (c) One of the following if a catalytic incinerator is operated:
 - (i) The inlet and exhaust gas temperatures are monitored continuously.
 - (ii) If an owner or operator elects to implement an inspection and maintenance plan for the catalytic incinerator that meets paragraph (C)(2)(f) of this rule, only the inlet gas temperature is monitored continuously.
 - (d) Control device efficiency is monitored continuously if a carbon absorber or control device other than a thermal or catalytic incinerator is operated.
 - (e) Operation records sufficient to demonstrate compliance with the requirements of this subdivision are maintained as required by paragraph (D) of this rule.
 - (f) For an owner or operator that elects to monitor the inlet temperature only of the catalytic incinerator, in accordance with paragraph (C)(2)(c)(ii) of this rule, an inspection and maintenance plan shall be developed, maintained on-site, and made readily available upon the request of the appropriate Ohio EPA district office or local air agency. At a minimum, the plan shall include the following:
 - (i) Annual sampling and analysis of the catalyst activity (i.e., conversion efficiency) following the manufacturer's or catalyst supplier's recommended procedures.

- (ii) Monthly inspection of the oxidizer system including the burner assembly and fuel supply lines for problems.
 - (iii) Annual internal and monthly external visual inspection of the catalyst bed to check for channeling, abrasion, and settling. If problems are found, corrective action consistent with the manufacturer's recommendations shall be implemented and a new performance test to determine destruction efficiency in accordance with paragraph (C) of rule 3745-21-10 of the Administrative Code shall be conducted.
- (3) Any owner or operator of a miscellaneous industrial adhesive and sealant application process using adhesives, sealants, adhesive primers, sealant primers, surface preparation solvents or cleanup solvents subject to this rule shall do the following:
 - (a) Store all VOC-containing adhesives, adhesive primers, and process-related waste materials in closed containers.
 - (b) Store all VOC-containing cleaning materials and used shop towels in closed containers.
 - (c) Ensure that mixing and storage containers used for VOC-containing cleaning materials, adhesives, adhesive primers, and process-related waste materials are kept closed at all times except when depositing or removing these materials.
 - (d) Minimize spills of VOC-containing cleaning materials, adhesives, adhesive primers, and process-related waste materials.
 - (e) Convey VOC-containing cleaning materials, adhesives, adhesive primers, and process-related waste materials from one location to another in closed containers or pipes.
 - (f) Minimize VOC emission from cleaning of application, storage, mixing, and conveying equipment by ensuring that equipment cleaning is performed without atomizing the cleaning solvent and all spent solvent is captured in closed containers.
- (4) The provisions of paragraphs (C)(1) to (C)(3) of this rule shall not apply to any emissions unit that meets the following:
 - (a) The director has determined that the otherwise applicable emission limitation in paragraph (C) of this rule is technically or economically

infeasible and has established an alternative reasonably available control technology emission limitation. The alternative limitation shall be the lowest emission limitation that the adhesives, adhesive primers, sealants and sealant primers operation is capable of meeting by the application of control technology that is reasonably available considering technological and economic feasibility. The alternative limitation shall be an emissions rate (e.g., pounds VOC per gallon) or overall per cent reduction but shall not be in terms of mass per time (e.g., pounds per hour).

(b) A final permit-to-install or permit-to-install and operate has been issued for the emissions unit pursuant to Chapter 3745-31 of the Administrative Code which contains terms and conditions that specify the control requirement or emission limitation that are the basis for the director's alternative limitation determination for the emissions unit, as described in paragraph (C)(4)(a) of this rule, and the permit-to-install or permit-to-install and operate has been issued by the Ohio EPA in a manner that makes the alternative limitation federally enforceable.

(c) USEPA has approved the alternative limitation as a revision to the Ohio state implementation plan.

(D) Recordkeeping and reporting.

(1) The owner or operator of each miscellaneous industrial adhesive and sealant application process subject to this rule shall maintain records demonstrating compliance with this rule, including, but not limited to, the following information:

(a) A list of each adhesive, sealant, adhesive primer, and sealant primer in use and in storage.

(b) A data sheet or material list which provides the material name, manufacturer identification, and material application.

(c) Catalysts, reducers or other components used and the mix ratio.

(d) The VOC content of each product as supplied.

(e) The final VOC content as applied.

(f) The monthly volume of each adhesive, sealant, adhesive primer, and sealant primer used.

- (2) Any owner or operator of a miscellaneous industrial adhesive and sealant application process who complies with paragraph (C)(2) of this rule in lieu of paragraph (C)(1) of this rule through the use of add-on air pollution control equipment shall record the key operating parameters for the control equipment, including but not limited to, the following information:
- (a) On a daily basis, the combustion temperature, inlet and exhaust gas temperatures and control device efficiency, as appropriate, pursuant to paragraph (C)(2) of this rule.
 - (b) Daily hours of operation.
 - (c) All maintenance performed including the date and type of maintenance.
 - (d) Any owner or operator of a miscellaneous industrial adhesive and sealant application process electing to comply with paragraph (C)(2)(c)(ii) of this rule, records, and a description of the results of each inspection and catalyst activity analysis, as specified in paragraph (C)(2)(f) of this rule, shall be maintained.
- (3) All records made to determine compliance with this rule shall be maintained for five years from the date such record is created and shall be made available to the director or any authorized representative of the director within ninety days of a request.

(E) Compliance procedures and test methods.

- (1) Except as provided in paragraphs (E)(3) to (E)(4) of this rule, the VOC and solids content of all non-aerosol adhesives, and adhesive primers shall be determined using USEPA method 24, as identified in 40 CFR part 60, appendix A.
- (2) The organic content of exempt organic compounds shall be determined using ASTM ~~D4457-02(2008)~~D4457, as applicable.
- (3) The VOC content of any plastic cement welding adhesive or primer shall be determined using SCAQMD method 316A.
- (4) To determine if a diluent is a reactive diluent, the percent of the reactive organic compound that becomes an integral part of the finished materials shall be determined using SCAQMD method 316A.
- (5) For adhesives that do not contain reactive diluents, pounds of VOC per gallon of adhesive, less water and exempt compounds, shall be calculated according to the following equation:

Pounds of VOC per gallon of adhesive = $(W_s - W_w - W_e) / (V_m - V_w - V_e)$

Where:

W_s = weight of volatile compounds, in pounds.

W_w = weight of water, in pounds.

W_e = weight of exempt compounds, in pounds.

V_m = volume of material, in gallons.

V_w = volume of water, in gallons.

V_e = volume of exempt compounds, in gallons.

- (6) For adhesives that contain reactive diluents, the VOC content of the adhesive is determined after curing. The pounds of VOC per gallon of adhesive, less water and exempt compounds, shall be calculated according to the following equation:

Pounds of VOC per gallon of adhesive = $(W_{rs} - W_{rw} - W_{re}) / (V_{rm} - V_{rw} - V_{re})$

Where:

W_{rs} = weight of volatile compounds not consumed during curing, in pounds.

W_{rw} = weight of water not consumed during curing, in pounds.

W_{re} = weight of exempt compounds not consumed during curing, in pounds.

V_{rm} = volume of material not consumed during curing, in gallons.

V_{rw} = volume of water not consumed during curing, in gallons.

V_{re} = volume of exempt compounds not consumed during curing, in gallons.

- (7) Pounds of VOC per gallon of material shall be calculated according to the following equation:

Pounds of VOC per gallon of material = $(W_s - W_w - W_e) / V_m$

Where:

W_s = weight of volatile compounds, in pounds.

W_w = weight of water, in pounds.

W_e = weight of exempt compounds, in pounds.

V_m = volume of material, in gallons.

(8) Per cent VOC by weight shall be calculated according to the following equation:

$$\% \text{ VOC by weight} = (W_v / W) \times 100$$

Where:

W_v = weight of VOCs in pounds.

W = weight of material in pounds.

(9) If add-on air pollution control equipment is used to meet this rule, the following emissions testing shall be applicable:

(a) The general provisions specified under paragraphs (A)(2) to (A)(5) of rule 3745-21-10 of the Administrative Code shall apply to compliance testing.

(b) The test methods and procedures of paragraph (C) of rule 3745-21-10 of the Administrative Code shall be followed.

For the purpose of demonstrating compliance with the emission control requirements of paragraph (C)(2) of this rule, the affected source shall be run at typical operating conditions and flow rates compatible with scheduled production during any emission testing.

(F) Compliance dates.

(1) The owner or operator of a miscellaneous industrial adhesive and sealant application process subject to this rule shall comply with this rule no later than the following dates:

(a) For any subject miscellaneous industrial adhesive and sealant application process located in Ashtabula, Cuyahoga, Geauga, Lake, Lorain, Medina, Portage, or Summit county for which installation commenced before May 12, 2011, the compliance date for the process is either May 12, 2012 or the date of initial startup of the process, whichever is later.

(b) For any subject miscellaneous industrial adhesive and sealant application process located in Ashtabula, Cuyahoga, Geauga, Lake, Lorain, Medina, Portage, or Summit county for which installation commenced on or after

May 12, 2011, the compliance date for the process is the initial startup date of the process.

(c) For any miscellaneous industrial adhesive and sealant application process located in Butler, Clermont, Hamilton or Warren county for which installation commenced before the effective date of this rule, the compliance date is either March 1, 2023 or the date of initial startup of the process, whichever is later.

(d) For any miscellaneous industrial adhesive and sealant application process located in Butler, Clermont, Hamilton or Warren county for which installation commenced on or after the effective date of this rule, the compliance date is the date of initial startup of the the process.

(2) The owner or operator of a miscellaneous industrial adhesive and sealant application process that is subject to this rule shall demonstrate compliance with paragraph (C)(2) of this rule by testing the control device on each subject source in accordance with paragraph (E)(9) of this rule according to the following:

(a) For any owner or operator of a miscellaneous industrial adhesive and sealant application process subject to paragraph (F)(1)(a) of this rule, by no later than ninety days after the process's compliance date. In addition, the Ohio EPA may accept the results of an emission test conducted prior to May 12, 2011, if the owner or operator provides information and data to the Ohio EPA which demonstrate that the test was witnessed by the Ohio EPA or local air agency, that an approved USEPA emission test method was employed, and that the operation of the process was consistent with the current operating conditions and operating capacity.

(b) For any owner or operator of a miscellaneous industrial adhesive and sealant application process subject to paragraph (F)(1)(b) of this rule, within one hundred eighty days after the miscellaneous industrial adhesive and sealant application process's compliance date.

(3) Additional testing of a subject miscellaneous industrial adhesive and sealant application process and its VOC add-on air pollution control equipment in accordance with paragraph (E)(9) of this rule may be required by the director to ensure continued compliance.

(G) Applicability notification, compliance certification, and permit application.

(1) The owner or operator of a miscellaneous industrial adhesive and sealant application process that is subject to this rule, is located in located in Ashtabula,

Cuyahoga, Geauga, Lake, Lorain, Medina, Portage, or Summit county, and has an initial startup before May 12, 2011 shall notify the appropriate Ohio EPA district office or local air agency in writing that the process is subject to this rule not later than July 11, 2011 (or within sixty days after the process becomes subject to this rule), providing the information specified in paragraph (G)(5) of this rule.

- (2) The owner or operator of a miscellaneous industrial adhesive and sealant application process that is subject to this rule, is located in Ashtabula, Cuyahoga, Geauga, Lake, Lorain, Medina, Portage, or Summit county, and has an initial startup on or after May 12, 2011 shall notify the appropriate Ohio EPA district office or local air agency in writing that the process is subject to this rule not later than either the date of initial startup of the subject process or July 11, 2011 (whichever is later), providing the information specified in paragraph (G)(5) of this rule. The application for a permit-to-install under rule 3745-31-02 of the Administrative Code may be used to fulfill the notification requirements of this paragraph.
- (3) The owner or operator of a miscellaneous industrial adhesive and sealant application process that is subject to this rule, is located in Butler, Clermont, Hamilton or Warren county, and has an initial startup of shipbuilding or ship repair operations before the effective date of this rule shall notify the appropriate Ohio EPA district office or local air agency in writing that the process is subject to this rule not later than sixty days after the effective date of this rule, providing the information specified in paragraph (G)(5) of this rule.
- (4) The owner or operator of a miscellaneous industrial adhesive and sealant application process that is subject to this rule, is located in Butler, Clermont, Hamilton or Warren county, and has an initial startup of shipbuilding or ship repair operations on or after the effective date of this rule shall notify the appropriate Ohio EPA district office or local air agency in writing that the process is subject to this rule not later than either the date of initial startup of the subject process or sixty days after the effective date of this rule (whichever is later), providing the information specified in paragraph (G)(5) of this rule. The application for a permit-to-install under rule 3745-31-02 of the Administrative Code may be used to fulfill the notification requirements of this paragraph.
- ~~(1)(5) The owner or operator of a miscellaneous industrial adhesive and sealant application process that is subject to this rule with an initial startup date before May 12, 2011 shall notify the Ohio EPA district office or local air agency in writing that the process is subject to this rule. The notification, which shall be submitted not later than July 11, 2011 (or within sixty days after the process~~

~~becomes subject to this rule),~~ required in paragraphs (G)(1) to (G)(4) of this rule shall provide the following information:

- (a) Name and address of the owner or operator.
 - (b) Address (i.e., physical location) of the facility.
 - (c) Equipment description and Ohio EPA application number (if assigned) of the subject process.
 - (d) Identification of the VOC emission requirement, the means of compliance, and the compliance date for the subject process.
 - (e) An application for an operating permit or an application for a modification to an operating permit in accordance with Chapter 3745-77 of the Administrative Code (for sources subject to the Title V permit program) or an application for a permit-to-install and operate or an application for a modification to a permit-to-install and operate in accordance with Chapter 3745-31 of the Administrative Code (for sources not subject to the Title V permit program) for each subject process that meets one of the following:
 - (i) The process does not possess an effective operating permit or permit-to-install and operate.
 - (ii) The process possesses an effective operating permit or permit-to-install and operate and the owner or operator cannot certify in writing to the director that such subject process is in compliance with this rule. An application for an operating permit or permit-to-install and operate is not required provided the subject process is operating under an effective permit and certifies compliance. Such certification shall include all compliance certification requirements under paragraph (G)(~~36~~) of this rule.
- ~~(2) The owner or operator of a miscellaneous industrial adhesive and sealant application process that is subject to this rule with an initial startup date on or after May 12, 2011 shall notify the Ohio EPA district office or local air agency in writing that the process is subject to this rule. The notification, which shall be submitted not later than either the date of initial startup of the subject process, or July 11, 2011 of this rule (whichever is later), shall provide the information listed under paragraph (G)(1) of this rule. The application for an installation permit under rule 3745-31-02 of the Administrative Code may be used to fulfill the notification requirements of this paragraph.~~

~~(3)~~(6) Compliance certification.

- (a) The owner or operator of a miscellaneous industrial adhesive and sealant application process that is subject to this rule shall notify the Ohio EPA district office or local air agency in writing within thirty days following the completion of any of the following:
- (i) For a process subject to the VOC emission requirements in paragraphs (C)(1) and (C)(3) of this rule, the first documented achievement of compliance with each of the requirements.
 - (ii) For a process subject to the VOC add-on air pollution control equipment in paragraph (C)(2) of this rule, the following:
 - (a) The completion of installation and initial use of a VOC emission control system for subject process.
 - (b) The completion of installation and initial use of any monitoring devices required under paragraph (C)(2) of this rule for the subject process.
 - (c) The completion of any compliance testing conducted in accordance with paragraph (F)(2) of this rule to demonstrate compliance with the applicable control requirements.
- (b) The compliance certification under paragraph (G)~~(36)~~(a) of this rule shall provide the following, where applicable:
- (i) A description of the requirements.
 - (ii) A description of the VOC emission control system.
 - (iii) A description of the monitoring devices.
 - (iv) A description of the records that document continuing compliance.
 - (v) The results of any compliance tests, including documentation of test data.
 - (vi) The results of any records that document continuing compliance, including calculations.
 - (vii) A statement by the owner or operator of the facility as to whether the subject process has complied with the requirements.

(H) Requirements for an owner or operator of a miscellaneous industrial adhesive and sealant application process that determines they are not subject to one or more of the following:

(1) The owner or operator of a miscellaneous industrial adhesive and sealant application process that determines the total actual VOC emissions, before the application of air pollution control systems, from all miscellaneous industrial adhesive application processes (including emissions from surface preparation and cleanup activities) at the facility are not equal to or greater than the limitation specified in paragraph (A)(1)(a) of this rule, and, therefore, the facility is not subject to paragraphs (B) to (G) of this rule, shall select one of the following methods and maintain the following records for a period of five years:

(a) Monthly recordkeeping method, as follows:

- (i) Total pounds or gallons of each adhesive, sealant, adhesive primer, sealant primer, cleanup solvent and surface preparation solvent used per calendar month.
- (ii) VOC content (per cent by weight or pounds per gallon, whichever is consistent with the records kept in paragraph (H)(1)(a)(i) of this rule) of each adhesive, sealant, adhesive primer, sealant primer, cleanup solvent and surface preparation solvent used per calendar month.
- (iii) The total monthly VOC emissions, before the application of capture systems and control devices, in pounds for all adhesives, sealant, adhesive primer, sealant primer, cleanup solvent and surface preparation solvent employed per calendar month.
- (iv) The rolling twelve-month summation of VOC emissions, in tons, before the application of control systems and devices. The rolling twelve-month summation shall be calculated as the total VOC emissions for the current calendar month, plus the total VOC emissions from the previous eleven calendar months.

(b) Daily emissions method.

Provided total VOC emissions are less than 15.0 pounds per day, the owner or operator may elect to maintain the following records in lieu of the records required under paragraph (H)(1)(a) of this rule:

- (i) Total pounds or gallons of each adhesive, sealant, adhesive primer, sealant primer, cleanup solvent and surface preparation solvent used per day.
 - (ii) VOC content (per cent by weight or pounds per gallon, whichever is consistent with the records kept in paragraph (H)(1)(b)(i) of this rule) of each adhesive, sealant, adhesive primer, sealant primer, cleanup solvent and surface preparation solvent used per day.
 - (iii) The total daily VOC emissions, before the application of capture systems and control devices, in pounds for all adhesives, sealant, adhesive primer, sealant primer, cleanup solvent and surface preparation solvent employed per day.
- (2) The owner or operator of a miscellaneous industrial adhesive application process that determines the process is not subject to paragraphs (C)(1), (D) and (E) of this rule because the use of all adhesives, sealants, adhesive primers or sealant primers in all processes are supplied by the manufacturer in containers with a net volume of sixteen fluid ounces or less, or a net weight of one pound or less, in accordance with paragraph (A)(2)(f) of this rule, shall maintain records for a period of five years identifying that all supplied containers of said materials meet the exemption.

Effective: 3/27/2022
Five Year Review (FYR) Dates: 11/29/2021 and 11/29/2026

CERTIFIED ELECTRONICALLY

Certification

03/17/2022

Date

Promulgated Under: 119.03
Statutory Authority: 3704.03(E)
Rule Amplifies: 3704.03(A), 3704.03(E)
Prior Effective Dates: 05/12/2011, 10/15/2015, 02/16/2019

3745-21-29

Control of volatile organic compound emissions from automobile and light-duty truck assembly coating operations, heavier vehicle assembly coating operations, and cleaning operations associated with these coating operations.

[Comment: For dates and availability of non-regulatory government publications, publications of recognized organizations and associations, federal rules, and federal statutory provisions referenced in this rule, see paragraph (JJ) of rule 3745-21-01 of the Administrative Code titled "referenced materials."]

(A) Applicability.

(1) Except as otherwise provided in paragraph (A)(3) of this rule, paragraphs (B) to (I) of this rule shall apply to the following operations at an automobile and light-duty truck assembly facility, at a facility that performs these operations on a contractual basis, or at a heavier vehicle assembly facility that meets the criteria under paragraph (A)(2) of this rule:

(a) All primary coatings applied to the following:

- (i) New automobile or new light-duty truck bodies.
- (ii) Body parts for new automobiles or new light-duty trucks.
- (iii) Other parts that are coated along with these bodies or body parts.

(b) Additional coatings applied during the vehicle assembly process. Additional coatings include glass bonding primer, adhesives, cavity wax, sealer, deadener, gasket/gasket sealing material, underbody coating, trunk interior coating, bedliner, weatherstrip adhesive and lubricating waxes/compounds.

(c) The coating of bodies or body parts for new heavier vehicles at an automobile and light-duty truck assembly facility or a heavier vehicle assembly facility that meet the applicability requirements of rule 3745-21-26 of the Administrative Code; however, the owner or operator elects to comply with this rule in lieu of rule 3745-21-26 of the Administrative Code.

(2) The coating operation meets the following:

(a) Is located at a facility where the total actual VOC emissions from all automobile and light-duty truck assembly coating operations identified in paragraph (A)(1) of this rule, including related cleaning operations, are

equal to or greater than 3.0 tons per rolling twelve-month period, before the application of control systems and devices.

- (b) Is located at a facility in Ashtabula, Butler, Clermont, Cuyahoga, Geauga, Hamilton, Lake, Lorain, Medina, Portage, ~~or~~ Summit, or Warren county.

(3) Exemptions.

- (a) Paragraphs (B) to (I) this rule shall not apply to any plastic or composites molding facility where all of the body parts topcoated at this facility for use in new automobiles, new light-duty trucks, or new heavier vehicles were fabricated (molded, stamped, formed, etc.) at this facility or at another plastic or composites molding facility which is jointly owned or operated with this facility, and none of the new vehicles in which these body parts are used are assembled at this facility; and the facility does not topcoat all of the body parts for any single new automobile, new light-duty truck, or heavier vehicle.

- (b) The following coatings are excluded from the emission limitations specified in paragraph (C) of this rule:

(i) Aerosol coatings.

(ii) Coatings supplied in containers with a net volume of sixteen ounces or less, or a net weight of one pound or less.

(iii) Coatings that meet the following low usage restrictions at the facility:

(a) Annual total usage of each separate coating formulation does not exceed fifty gallons.

(b) Combined annual total usage of such coating formulations does not exceed two hundred gallons.

(B) Definitions.

The definitions applicable to this rule are contained in paragraphs (A), (B), and (D) of rule 3745-21-01 of the Administrative Code.

(C) Surface coating emission limitations.

No owner or operator of facility subject to this rule may cause, allow or permit the discharge into the ambient air of any VOC in excess of the following limitations:

(1) For primary coatings:

(a) For EDP primer coating operations:

(i) When the solids turnover ratio is 0.16 or greater; 0.70 pound of VOC per gallon of solids.

(ii) When the solids turnover ratio is greater than or equal to 0.040 and less than 0.160; $0.70 \times 350^{(0.160-RT)}$ pounds of VOC per gallon of solids.

(iii) When the solids turnover ratio is less than 0.040, there is no emission limitation.

(b) For primer coating operations that are neither EDP primer nor primer-surfacer, 1.9 pounds of VOC per gallon of coating, excluding water and exempt solvents, or, if a control system is employed, 2.6 pounds of VOC per gallon of solids.

(c) For primer-surfacer coating operations, 12.0 pounds of VOC per gallon of deposited solids. This emissions limitation is a daily volume-weighted average of the entire primer-surfacer coating operations (i.e., all spray booths, flash-off areas and bake ovens where primer-surfacer coatings are applied, dried, and cured, except those spray booths, flash-off areas and bake ovens in the final repair coating operations).

(d) For topcoat coating operations, 12.0 pounds of VOC per gallon of deposited solids. This emissions limitation is a daily volume-weighted average of the entire topcoat coating operations (i.e., all spray booths, flash-off areas and bake ovens where topcoat coatings are applied, dried, and cured, except those spray booths, flash-off areas and bake ovens in the final repair coating operations).

(e) For combined primer-surfacer and topcoat coating operations, 12.0 pounds of VOC per gallon of deposited solids. This emissions limitation is a daily volume-weighted average of the entire combined primer-surfacer and topcoat coating operations (i.e., all spray booths, flash-off areas and bake ovens where primer-surfacer coatings and topcoat coatings are applied, dried, and cured, except those spray booths, flash-off areas and bake ovens in the final repair coating operations).

[Comment: This is an alternative emission limitation in place of the emission limitations separately applicable to primer-surfacer coating operations and topcoat coating operations at the facility.]

- (f) For final repair coating operations, 4.8 pounds of VOC per gallon of coating, excluding water and exempt solvents, or, if a control system is employed, 13.8 pounds of VOC per gallon of solids.

(2) For additional coatings:

- (a) Automobile and light-duty truck glass bonding primer, 7.5 pounds VOC per gallon excluding water and exempt compounds.
- (b) Automobile and light-duty truck adhesive, 2.1 pounds VOC per gallon excluding water and exempt compounds.
- (c) Automobile and light-duty truck cavity wax, 5.4 pounds VOC per gallon excluding water and exempt compounds.
- (d) Automobile and light-duty truck sealer, 5.4 pounds VOC per gallon excluding water and exempt compounds.
- (e) Automobile and light-duty truck deadener, 5.4 pounds VOC per gallon excluding water and exempt compounds.
- (f) Automobile and light-duty truck gasket/gasket sealing material, 1.7 pounds VOC per gallon excluding water and exempt compounds.
- (g) Automobile and light-duty truck underbody coating, 5.4 pounds VOC per gallon excluding water and exempt compounds.
- (h) Automobile and light-duty truck trunk interior coating, 5.4 pounds VOC per gallon excluding water and exempt compounds.
- (i) Automobile and light-duty truck bedliner, 1.7 pounds VOC per gallon excluding water and exempt compounds.
- (j) Automobile and light-duty truck weatherstrip adhesive, 6.3 pounds VOC per gallon excluding water and exempt compounds.
- (k) Automobile and light-duty truck lubricating wax/compound, 5.8 pounds VOC per gallon excluding water and exempt compounds.

(D) An owner or operator may achieve compliance with the limitations in paragraph (C) of this rule by using add-on air pollution control equipment. Such add-on air pollution control equipment shall meet paragraph (F)(7) of this rule.

(E) Work practices for coating-related activities and cleaning materials.

Any owner or operator of coating operations for which emission limitations are specified under paragraph (C) of this rule shall do the following:

- (1) Store all VOC-containing coatings, thinners, and coating-related waste materials in closed containers.
- (2) Ensure that mixing and storage containers used for VOC-containing coatings, thinners, and coating-related waste materials are kept closed at all times except when depositing or removing these materials.
- (3) Minimize spills of VOC-containing coatings, thinners, and coating-related waste materials.
- (4) Convey VOC-containing coatings, thinners, and coating-related waste materials from one location to another in closed containers or pipes.
- (5) Minimize VOC emission from cleaning of storage, mixing, and conveying equipment.
- (6) Develop and implement a work practice plan to minimize VOC emissions from cleaning and from purging of equipment associated with all coating operations for which requirements are specified in paragraphs (C) and (D) of this rule. The work practice plan shall specify practices and procedures to ensure that VOC emissions from the following operations are minimized:
 - (a) Vehicle body wiping.
 - (b) Coating line purging.
 - (c) Flushing of coating systems.
 - (d) Cleaning of spray booth grates.
 - (e) Cleaning of spray booth walls.
 - (f) Cleaning of spray booth equipment.
 - (g) Cleaning external spray booth areas.

- (h) Other housekeeping measures (e.g., keeping solvent-laden rags in closed containers).

[Comment: If a facility subject to this rule already has a work practice plan in place under the national emission standards for hazardous air pollutants (NESHAP), the facility can add to its NESHAP work practice plan the practices and procedures for minimizing non-HAP VOC emissions].

(F) Compliance procedures and test methods.

- (1) The VOC content of a coating, other than a reactive adhesive, shall be determined by the owner or operator in accordance with paragraph (B) of rule 3745-21-10 of the Administrative Code, wherein formulation data or USEPA method 24 procedures (which include various ASTM measurement methods) may be employed.

- (2) VOC content of a reactive adhesive.

The VOC content of a reactive adhesive shall be determined from coating formulation data from the coating user or coating manufacturer, or by the analytical procedures of 40 CFR part 63, subpart P, appendix A. In the event of a dispute between coating formulation data and data obtained by analytical procedures, the data obtained by analytical procedures shall be employed, except as otherwise provided in paragraph (B)(12) of rule 3745-21-10 of the Administrative Code.

- (3) VOC content of a coating applied by a dip coater.

- (a) VOC content of a coating applied by a dip coater (rolling thirty-day average VOC content) that is not an EDP primer.

The as-applied VOC content of a coating applied by a dip coater shall be determined by the owner or operator as a rolling thirty-day average of the VOC content of the material (coating and thinner) added to the reservoir of the dip coater. The rolling thirty-day average VOC content (C30), expressed in pounds of VOC per gallon of coating, excluding water and exempt solvents, as applied, shall be calculated for each day of operation of the dip coater as follows:

$$C_{30} = \frac{\sum_{i=1}^n (A_{i,30})(C_{i, \text{VOC}})}{\sum_{i=1}^n (A_i)(V_{i, \text{VOC}} + V_{i, \text{solids}})}$$

Where:

$A_{i,30}$ = amount of material i added to the reservoir of the dip coater during a thirty-day period consisting of the day of operation of the dip coater plus the previous twenty-nine calendar days, expressed in gallons

$C_{i,\text{VOC}}$ = VOC content of material i expressed in pounds of VOC per gallon.

$V_{i,\text{solids}}$ = volume fraction of solids (nonvolatile matter) in material i .

$V_{i,\text{VOC}}$ = volume fraction of VOC in material i .

i = subscript denoting a specific material (coating or thinner) added to the reservoir of the dip coater during the thirty-day period.

n = total number of materials (coatings and thinners) added to the reservoir of the dip coater during the thirty-day period.

(b) VOC content of an EDP primer (calendar month average).

The as applied VOC content of an EDP primer shall be determined by the owner or operator as a monthly average of the VOC content of the material (coating and thinner) added to the reservoir of the dip coater during a calendar month. The monthly average VOC content (C_{month}), expressed in pounds of VOC per gallon of solids, as applied, shall be calculated for each month of operation of the dip coater as follows:

$$C_{\text{month}} = \frac{\sum_{i=1}^n (A_{i,\text{month}})(C_{i,\text{VOC}})}{\sum_{i=1}^n (A_{i,\text{month}})(V_{i,\text{solids}})}$$

Where:

$A_{i,\text{month}}$ = amount of material i added to the reservoir of the dip coater during a calendar month, expressed in gallons.

$C_{i,\text{VOC}}$ = VOC content of material i expressed in pounds of VOC per gallon.

$V_{i,\text{solids}}$ = volume fraction of solids (nonvolatile matter) in material i .

i = subscript denoting a specific material (coating or thinner) added to the reservoir of the dip coater during the calendar month.

n = total number of materials (coatings and thinners) added to the reservoir of the dip coater during the calendar month.

- (4) Compliance with the limitations specified in paragraphs (C)(1)(c) to (C)(1)(e) of this rule shall be determined each day of operation in accordance with the publication entitled "Protocol for determining the daily volatile organic compound emission rate of automobile and light-duty truck primer-surfacer and topcoat operations" (EPA-453/R-08-002). Compliance with the limitation specified in paragraph (C)(1)(a) of this rule shall be determined each day of operation and is based upon a weighted average by volume of all coating materials employed in the coating operation in the past thirty days. Compliance with the limitation specified in paragraphs (C)(1)(b) and (C)(1)(f) of this rule

is based upon a weighted average by volume of all coating materials employed in the coating operation in any one day.

- (5) The solids turnover ratio (R_T) of an EDP coating operation shall be calculated as follows:

$$R_T = L_S/L_E$$

Where:

L_S = total volume of coating solids that is added to the EDP coating operation in a calendar month (gallons).

L_E = total volume design capacity of the EDP system, which is the total liquid volume contained in the EDP system's tanks, pumps, recirculating lines, filters, etc. at the system's designed liquid operating level (gallons).

- (6) Manufacturer's formulation data may be accepted in lieu of the analytical procedures above. In the event of a dispute between coating formulation data and data obtained by analytical procedures, the data obtained by analytical procedures shall be employed, except as otherwise provided in paragraph (B) (12) of rule 3745-21-10 of the Administrative Code.

- (7) Add-on pollution control equipment.

For add-on air pollution control equipment employed in accordance with paragraph (D) of this rule, the owner or operator shall do the following:

- (a) Meet the same monitoring requirements as contained in 40 CFR 63.3168 and, if appropriate, "Protocol for Determining the Daily Volatile Organic Compound Emission Rate of Automobile and Light-Duty Truck Primer-Surfacer and Topcoat Operations" (EPA-453/R-08-002).
- (b) Conduct a compliance test to determine the capture efficiency of a capture system, the control efficiency of a control device (or each control device if a combination of control devices is employed), and the overall control efficiency of the add-on air pollution control equipment in accordance with 40 CFR 63.3165 and 40 CFR 63.3166, except where 40 CFR 63.3165 refers to the "Protocol for Determining Daily Volatile Organic Compound Emission Rate of Automobile and Light-Duty Truck Topcoat Operations," EPA-450/3-88-018, EPA-453/R-08-002 shall be used instead, and, if appropriate, "Protocol for Determining the Daily Volatile Organic Compound Emission Rate of Automobile and

Light-Duty Truck Primer-Surfacer and Topcoat Operations" (EPA-453/R-08-002). During the compliance test, the owner or operator shall establish the operating limits (operating parameter values) for the required monitoring devices by following the requirements contained in 40 CFR 63.3167 and, if appropriate, "Protocol for Determining the Daily Volatile Organic Compound Emission Rate of Automobile and Light-Duty Truck Primer-Surfacer and Topcoat Operations" (EPA-453/R-08-002).

(G) Recordkeeping and reporting.

- (1) The following types of records are to be maintained by the owner or operator of a facility subject to this rule:
 - (a) Compliance demonstration records for coating operations.
 - (b) Compliance demonstration records for coating-related activities and cleaning materials.
 - (c) Monitoring records for add-on air pollution control systems subject to the add-on pollution control requirements of paragraph (D) of this rule.
- (2) For any coating operation subject to paragraph (C) of this rule, the owner or operator shall maintain the following records:
 - (a) For each coating in use at the facility:
 - (i) The name and VOC content as received and as applied.
 - (ii) The type of coating, as identified under paragraph (C) of this rule.
 - (b) All data, calculations, and test results (including USEPA method 24 results) used in determining the VOC content of each coating, expressed in pounds of VOC per gallon of coating, excluding water and exempt solvents, as applied.
 - (c) The amount (gallons) of each coating used each month at the facility.
 - (d) For each EDP primer coating operation, calculate the turnover ratio (R_T) when used to adjust the VOC emission limit as described in paragraphs (C)(1)(a)(ii) and (C)(1)(a)(iii) of this rule, by the following equation:

$$R_T = V_S / V_E, \text{ truncated after three decimal places}$$

Where:

V_E = volume of EDP primer coating tank, in gallons.

V_s = volume of solids added to the EDP primer coating tank during the month, in gallons.

V_s = summation of $(A_{i,\text{month}})(V_{i,\text{solids}})$ for $i=1$ to $i=n$

$A_{i,\text{month}}$ = amount of material i added to the reservoir of the dip coater during a calendar month, expressed in gallons.

$V_{i,\text{solids}}$ = volume fraction of solids (nonvolatile matter) in material i .

i = subscript denoting a specific material (coating or thinner) added to the reservoir of the dip coater during the calendar month.

n = total number of materials (coatings and thinners) added to the reservoir of the dip coater during the calendar month.

Then calculate or select the appropriate limit according to paragraph (C)(1)(a) of this rule.

- (e) For any coating operation subject to the add-on pollution control equipment requirements of paragraph (D) of this rule:
 - (i) Identification of the coating line or coating operation.
 - (ii) Documentation on the overall control efficiency of each individual add-on pollution control equipment and the overall control efficiency of the add-on pollution control system, including design estimates and the results of compliance tests conducted pursuant to paragraph (F)(7) of this rule.
 - (iii) For any coating that is controlled by add-on pollution control equipment, the name of the coating, the dates (or time periods) of control, and the amount (gallons) of such coating controlled each month.
- (f) Records pertaining to a rolling thirty-day average VOC content for a dip coater, other than an EDP primer coating operation:
 - (i) For each day of operation, the gallons of each material (coating and thinner) added to the dip coater reservoir.

- (ii) The VOC content (in pounds of VOC per gallon), volume fraction VOC, and volume fraction solids for each material added to the dip coater reservoir.
 - (iii) For each day of operation, the rolling thirty-day average VOC content in pounds of VOC per gallon of coating, excluding water and exempt solvent, as applied, as determined in accordance with paragraph (F)(3) of this rule.
- (g) Records pertaining to a monthly average VOC content for an EDP primer coating operation:
 - (i) For each day of operation, the gallons of each material (coating and thinner) added to the dip coater reservoir.
 - (ii) The VOC content (in pounds of VOC per gallon), volume fraction VOC, and volume fraction solids for each material added to the dip coater reservoir.
 - (iii) For month of operation, the monthly average VOC content in pounds of VOC per gallon of solids, as determined in accordance with paragraph (F)(3)(b) of this rule.
- (h) Records pertaining a coating line subject to paragraph (C)(1)(b) or paragraph (C)(1)(f) of this rule in which the owner or operator elects to demonstrate the ongoing status of compliance with the applicable emission limitation by means of a daily volume-weighted average VOC content:
 - (i) Date of operation.
 - (ii) The name and identification number of each coating, as applied on the date of operation.
 - (iii) The mass of VOC per volume (excluding water and exempt solvents) and the volume of each coating (excluding water and exempt solvents), as applied on the date of operation.
 - (iv) The daily volume-weighted average VOC content of all coatings, as applied on the date of operation, calculated in accordance with the equation specified in paragraph (B)(9) of rule 3745-21-10 of the Administrative Code for $C_{voc,2}$.

(i) For any coating operation subject to paragraph (C)(1)(c), (C)(1)(d) or (C)(1)(e) of this rule, the owner or operator shall maintain the records specified in "Protocol for determining the daily volatile organic compound emission rate of automobile and light-duty truck primer-surfacer and topcoat operations" (EPA-453/R-08-002).

(3) Compliance demonstration records for coating-related activities and cleaning materials.

For the coating-related activities and cleaning materials, the owner or operator shall maintain the following records on a monthly basis:

(a) A copy of any documents and the work implementation plan that address the procedures for ensuring compliance with the work practices under paragraph (E) of this rule.

(b) A determination on whether the work practices are being met.

(4) Monitoring records for add-on pollution control equipment.

For an add-on pollution control system that is employed in accordance with paragraph (D) of this rule, the owner or operator shall maintain the same monitoring records as specified under paragraph (K)(5) of rule 3745-21-15 of the Administrative Code.

(5) All records made to determine compliance with this rule shall be maintained for five years from the date such record is created and shall be made available to the director or any authorized representative of the director within ninety days of a request.

(H) Compliance dates.

(1) The owner or operator of a coating operation that is subject to this rule shall comply with this rule no later than the following dates:

(a) For any subject coating operation located in Ashtabula, Cuyahoga, Geauga, Lake, Lorain, Medina, Portage, or Summit county for which installation commenced before ~~the~~ May 12, 2011, the compliance date for the coating operation is either May 12, 2012 or the date of initial startup of the coating operation, whichever is later.

(b) For any subject coating operation located in Ashtabula, Cuyahoga, Geauga, Lake, Lorain, Medina, Portage, or Summit county for which installation

commenced on or after May 12, 2011, the compliance date for the coating operation is the initial startup date of the coating operation.

(c) For any subject coating operation located in Butler, Clermont, Hamilton or Warren county for which installation commenced before the effective date of this rule, the compliance date is either March 1, 2023 or the date of initial startup of the coating operation, whichever is later.

(d) For any subject coating operation located in Butler, Clermont, Hamilton or Warren county for which installation commenced on or after the effective date of this rule, the compliance date is the date of initial startup of the coating operation.

(2) The owner or operator of a coating operation that is subject to this rule shall demonstrate compliance with paragraph (D) of this rule by testing the control device on each subject source in accordance with paragraph (F)(7) of this rule according to the following:

(a) For any owner or operator of a coating operation subject to paragraph (H)(1) (a) of this rule, by no later than one hundred eighty days after the coating operations compliance date.

(b) For any owner or operator of a coating operation subject to paragraph (H)(1)(b) of this rule, within one hundred eighty days after the coating operation's compliance date.

(c) The Ohio EPA may accept the results of an emission test conducted prior to May 12, 2011, if the owner or operator provides information and data to the Ohio EPA which demonstrate that the test was witnessed by the Ohio EPA or local air agency, that an approved USEPA emission test method was employed, and that the operation of the process was consistent with the current operating conditions and operating capacity.

(3) Additional testing of a subject coating operation and its VOC add-on air pollution control equipment in accordance with paragraph (F)(7) of this rule may be required by the director to ensure continued compliance.

(I) Applicability notification, compliance certification and permit requirements.

(1) The owner or operator of a coating operation that is subject to this rule, is located in located in Ashtabula, Cuyahoga, Geauga, Lake, Lorain, Medina, Portage, or Summit county, and has an initial startup of the coating operation before May 12, 2011 shall notify the appropriate Ohio EPA district office or local air agency in writing that the coating operation is subject to this rule not later than July 11,

2011 (or within sixty days after the coating operation becomes subject to this rule), providing the information specified in paragraph (I)(5) of this rule.

- (2) The owner or operator of a coating operation that is subject to this rule, is located in Ashtabula, Cuyahoga, Geauga, Lake, Lorain, Medina, Portage, or Summit county, and has an initial startup of the coating operation on or after May 12, 2011 shall notify the appropriate Ohio EPA district office or local air agency in writing that the coating operation is subject to this rule not later than either the date of initial startup of the the subject coating operation or July 11, 2011 (whichever is later), providing the information specified in paragraph (I)(5) of this rule. The application for a permit-to-install under rule 3745-31-02 of the Administrative Code may be used to fulfill the notification requirements of this paragraph.
- (3) The owner or operator of a coating operation that is subject to this rule, is located in Butler, Clermont, Hamilton or Warren county, and has an initial startup of the coating operation before the effective date of this rule shall notify the appropriate Ohio EPA district office or local air agency in writing that the coating operation is subject to this rule not later than sixty days after the effective date of this rule, providing the information specified in paragraph (I) (5) of this rule.
- (4) The owner or operator of a coating operation that is subject to this rule, is located in Butler, Clermont, Hamilton or Warren county, and has an initial startup of the coating operation on or after the effective date of this rule shall notify the appropriate Ohio EPA district office or local air agency in writing that the coating operation is subject to this rule not later than either the date of initial startup of the the subject coating operation or sixty days after the effective date of this rule (whichever is later), providing the information specified in paragraph (I)(5) of this rule. The application for a permit-to-install under rule 3745-31-02 of the Administrative Code may be used to fulfill the notification requirements of this paragraph.
- ~~(1)(5) The owner or operator of a coating operation that is subject to this rule with an initial startup date before May 12, 2011 shall notify the Ohio EPA district office or local air agency in writing that the coating operation is subject to this rule. The notification, which shall be submitted not later than July 11, 2011 (or within sixty days after the coating operation becomes subject to this rule), required in paragraphs (I)(1) to (I)(4) of this rule shall provide the following information:~~
- (a) Name and address of the owner or operator.
 - (b) Address (i.e., physical location) of the facility.

- (c) Equipment description and Ohio EPA application number (if assigned) of the subject process.
 - (d) Identification of the VOC emission requirement, the means of compliance, and the compliance date for the subject process.
 - (e) An application for an operating permit or an application for a modification to an operating permit in accordance with Chapter 3745-77 of the Administrative Code (for sources subject to the Title V permit program) or an application for a permit-to-install and operate or an application for a modification to a permit-to-install and operate in accordance with Chapter 3745-31 of the Administrative Code (for sources not subject to the Title V permit program) for each subject process that meets one of the following:
 - (i) The process does not possess an effective operating permit or permit-to-install and operate.
 - (ii) The process possesses an effective operating permit or permit-to-install and operate and the owner or operator cannot certify in writing to the director that such subject process is in compliance with all requirements of this rule. An application for an operating permit or permit-to-install and operate is not required provided the subject process is operating under an effective permit and certifies compliance. Such certification shall include all compliance certification requirements under paragraph (I)(36) of this rule.
- ~~(2) The owner or operator of a coating operation that is subject to this rule with an initial startup date on or after May 12, 2011 shall notify the Ohio EPA district office or local air agency in writing that the coating operation is subject to this rule. The notification, which shall be submitted not later than either the date of initial startup of the subject coating operation, or July 11, 2011 (whichever is later), shall provide the information listed under paragraph (I)(1) of this rule. The application for an installation permit under rule 3745-31-02 of the Administrative Code may be used to fulfill the notification requirements of this paragraph.~~
- ~~(3)(6)~~ Compliance certification.
- (a) The owner or operator of a coating operation that is subject to this rule shall notify the Ohio EPA district office or local air agency in writing within thirty days following the completion of any of the following requirements:

- (i) For a process subject to the VOC emission requirements in paragraph (C) of this rule, the first documented achievement of compliance with each of the requirements.
- (ii) For a process subject to the VOC add-on air pollution control equipment in paragraph (D) of this rule:
 - (a) The completion of installation and initial use of a VOC emission control system for subject process.
 - (b) The completion of installation and initial use of any monitoring devices required under paragraph (F)(7) of this rule for the subject process.
 - (c) The completion of any compliance testing conducted in accordance with paragraph (F)(7) of this rule to demonstrate compliance with the applicable control requirements.
- (b) The compliance certification under paragraph (I)(36)(a) of this rule shall provide the following, where applicable:
 - (i) A description of the requirements.
 - (ii) A description of the VOC emission control system.
 - (iii) A description of the monitoring devices.
 - (iv) A description of the records that document continuing compliance.
 - (v) The results of any compliance tests, including documentation of test data.
 - (vi) The results of any records that document continuing compliance, including calculations.
 - (vii) A statement by the owner or operator of the facility as to whether the subject process has complied with the requirements.
- (J) Requirements for an owner or operator of an automobile and light-duty truck assembly plant coating operation that determines ~~they are~~ the operation is not subject to one or more of the following:
 - (1) The owner or operator of a coating operation that determines the facility's total actual VOC emissions, before the application of control systems and devices,

from all automobile and light-duty truck assembly plant coating operations, including related cleaning activities, are not equal to or greater than the limitation specified in paragraph (A)(2)(a) of this rule, shall select one of the following methods and maintain the following records for a period of five years:

(a) Monthly recordkeeping method, as follows.

- (i) Total pounds or gallons of each coating and cleaning solvent used per calendar month.
- (ii) VOC content (per cent by weight or pounds per gallon, whichever is consistent with the records kept in paragraph (J)(1)(a)(i) of this rule) of each coating and cleaning solvent used per calendar month.
- (iii) The total monthly VOC emissions, before the application of capture systems and control devices, in pounds for all coatings and cleaning solvents employed per calendar month.
- (iv) The rolling twelve-month average of VOC emissions, in tons, before the application of capture systems and control devices. The rolling twelve-month average shall be calculated as the total VOC emissions, for the current calendar month, plus the total VOC emissions from the previous eleven calendar months.

(b) Daily emissions method.

Provided total VOC emissions are less than 15.0 pounds per day, the owner or operator may elect to maintain the following records in lieu of the records required under paragraph (J)(1)(a) of this rule:

- (i) Total pounds or gallons of each coating and cleaning solvent used per day.
- (ii) VOC content (per cent by weight or pounds per gallon, whichever is consistent with the records kept in paragraph (J)(1)(b)(i) of this rule) of each coating used per day.
- (iii) The total daily VOC emissions, before the application of capture systems and control devices, in pounds for all coatings employed per day.

(2) The owner or operator of a coating operation that determines a coating is not subject to paragraph (C) of this rule because the use of the coating in all processes are supplied by the manufacturer in containers with a net volume

of sixteen ounces or less, or a net weight of one pound or less, in accordance with paragraph (A)(3)(b)(ii) of this rule, shall maintain records for a period of five years identifying that all supplied containers of said materials meet the exemption.

- (3) The owner or operator of a coating operation that determines a coating is not subject to paragraph (C) of this rule because the use of the coating in all processes meets the low usage coating exemption, in accordance with paragraph (A)(3)(b)(iii) of this rule, shall maintain the following records for a period of five years:
 - (a) The name of each separate coating formulation.
 - (b) The amount (gallons) used during the month at the facility for each separate coating formulation.
 - (c) The total amount (gallons) used during the calendar year at the facility for each separate coating formulation and for all such coatings formulations combined.

Effective: 3/27/2022
Five Year Review (FYR) Dates: 11/29/2021 and 11/29/2026

CERTIFIED ELECTRONICALLY

Certification

03/17/2022

Date

Promulgated Under: 119.03
Statutory Authority: 3704.03(E)
Rule Amplifies: 3704.03(A), 3704.03(E)
Prior Effective Dates: 05/12/2011, 10/15/2015, 02/16/2019

Article II

Copy of Public Notice and
Director's Findings & Orders

**NOTICE OF ADOPTION OF RULES
OHIO ENVIRONMENTAL PROTECTION AGENCY
OHIO ADMINISTRATIVE CODE (OAC) CHAPTER 3745-21**

Notice is hereby given that the Director of the Ohio Environmental Protection Agency (Ohio EPA) has adopted new and amended rules contained in Ohio Administrative Code (OAC) Chapter 3745-21, "Carbon Monoxide, Photochemically Reactive Materials, Hydrocarbons, and Related Materials Standards."

These rules establish requirements for the control of emissions of volatile organic compounds (VOCs) and carbon monoxide (CO) from stationary emission sources. The purpose of this rule making was to adopt mandatory Reasonably Available Control Technology (RACT) requirements for the Cincinnati and Cleveland 2015 ozone nonattainment areas. Ohio EPA is also amending these rules to address minor changes needed for clarification and Legislative Service Commission (LSC) formatting protocol.

The Director's order of adoption was issued on March 17, 2022. The adoption of these amended rules will become effective on **Sunday, March 27, 2022.**

Copies of the new and amended rules can be found on Ohio EPA's website at <https://epa.ohio.gov/divisions-and-offices/air-pollution-control/regulations>.

The Director's action in this matter is pursuant to the procedural requirements of Ohio Revised Code Chapter 119 and is based upon the record of the public hearing conducted by Ohio EPA on January 3, 2022.

You are hereby notified that this action of the Director is final and may be appealed to the Environmental Review Appeals Commission pursuant to Section 3745.04 of the Ohio Revised Code. The appeal must be in writing and set forth the action complained of and the grounds upon which the appeal is based. The appeal must be filed with the Commission within thirty (30) days after notice of the Director's action. The appeal must be accompanied by a filing fee of \$70.00, made payable to "Treasurer, State of Ohio," which the Commission, in its discretion, may reduce if by affidavit you demonstrate that payment of the full amount of the fee would cause extreme hardship. Notice of the filing of the appeal shall be filed with the Director within three (3) days of filing with the Commission. Ohio EPA requests that a copy of the appeal be served upon the Ohio Attorney General's Office, Environmental Enforcement Section. An appeal may be filed with the Environmental Review Appeals Commission at the following address:

Environmental Review Appeals Commission
30 East Broad St., 4th Floor
Columbus, Ohio 43215

By:  Date: _____

BEFORE THE

3/17/2022

OHIO ENVIRONMENTAL PROTECTION AGENCY

In the Matter of:

**The Adoption of Amended
Rules 3745-21-01, 3745-21-04,
3745-21-07, 3745-21-09,
3745-21-10, 3745-21-15, and
3745-21-18 through 3745-21-29,
and New Rule 3745-21-11 of
the Ohio Administrative Code**

:
:
:
:
:
:
:
:
:
:
:
:
:
:
:

**Director's Final Findings and
Orders**

FINDINGS AND ORDERS

The Director of Environmental Protection, having considered in compliance with the Administrative Procedure Act the adoption of the new and amended rules of the Ohio Administrative Code cited above, finds:

1. That due notice of a public hearing in this matter pursuant to the Administrative Procedure Act was given, that a public hearing was held on January 3, 2022 both virtually and in Columbus, Ohio, and that all interested persons were afforded the opportunity to be heard; and
2. That upon due consideration, the adoption of the new and amended rules of the Ohio Administrative Code cited above, is reasonable and lawful and within the purview of authority provided by law.

It is therefore

ORDERED that amended rules 3745-21-01, 3745-21-04, 3745-21-07, 3745-21-09, 3745-21-10, 3745-21-15, and 3745-21-18 through 3745-21-29, and new rule 3745-21-11 of the Ohio Administrative Code be adopted in final form.

It is further

ORDERED that the effective date of said adoption shall be March 27, 2022.

It is further

ORDERED that copies of these Findings and Orders and certified copies of said new and amended rules shall be filed with the Secretary of State, the Joint Committee on Agency Rule Review, the Legislative Services Commission, and the Department of Development's Office of Small and Developing Business, as required by law.

APPEAL RIGHTS

You are hereby notified that this action of the Director is final and may be appealed to the Environmental Review Appeals Commission pursuant to Section 3745.04 of the Ohio Revised Code. The appeal must be in writing and set forth the action complained of and the grounds upon which the appeal is based. The appeal must be filed with the Commission within thirty (30) days after notice of the Director's action. The appeal must be accompanied by a filing fee of \$70.00, made payable to "Treasurer, State of Ohio," which the Commission, in its discretion, may reduce if by affidavit you demonstrate that payment of the full amount of the fee would cause extreme hardship. Notice of the filing of the appeal shall be filed with the Director within three (3) days of filing with the Commission. Ohio EPA requests that a copy of the appeal be served upon the Ohio Attorney General's Office, Environmental Enforcement Section. An appeal may be filed with the Environmental Review Appeals Commission at the following address:

Environmental Review Appeals Commission
30 East Broad St., 4th Floor
Columbus, OH 43215



Laurie A. Stevenson, Director
Ohio Environmental Protection Agency

Issued at Columbus, Ohio this 17th day of March, 2022.

Article III

Evidence Ohio EPA
Followed Rule Adoption
Procedures

Evidence Ohio EPA Followed Rule Adoption Procedures

Ohio Revised Code (ORC) 119.03, Procedures for adoption, amendment, or rescission of rules; finding that fiscal analysis is incomplete or inaccurate, outlines the requirements Ohio EPA must follow during the rule-making process. A copy of ORC 119.03 can be provided upon request. Ohio EPA fully complied with the requirements of this law and has provided evidence on the major requirements below:

1. ORC 119.03(A): Reasonable public notice shall be given in the register of Ohio at least 30 days prior to the date set for a hearing.

Ohio's electronic rule filing system automatically posts public notices in the Ohio Register when rules are proposed. A copy of the Public Hearing notice is included (Attachment A). The Public Hearing notice was placed in the Ohio Register on November 29, 2021. Ohio EPA held a public hearing on January 3, 2022 in Columbus, Ohio. This hearing was held thirty-five days after the notice was placed in the register. The ORC 119.03 requirements for public notice contents were met as evidenced by comparing the public notice and ORC 119.03 (A)(1)-(4). In addition to the Register of Ohio, Ohio EPA also placed an advertisement in the major newspapers throughout the state. Copies can be provided upon request.

2. ORC 119.03(B): The required materials must be filed with the secretary of state and the director of the legislative service commission (LSC).

Ohio's electronic filing system automatically generates a letter when all the required elements have been uploaded on the system and the package is proposed. This letter is included (Attachment B1). On February 14, 2022, OAC rule 3745-21-09 was re-filed to make minor clarifications. The confirmation letter from this filing is also included (Attachment B2).

Ohio EPA also complied with all requirements for incorporated materials. In addition, the answers to questions eight and nine of each of the Rule Summary and Fiscal Analysis (RSFA) documents are provided (Attachments C1 and C2).

3. ORC 119.03(C): Conduct public hearings as advertised.

Ohio EPA conducted the public hearing on January 3, 2022 as identified in the Public Hearing notice. A copy of the hearings transcript may be provided upon request.

4. ORC 119.03(D): After the period of time when legislative review and invalidation may occur expires, the agency may issue an order adopting the rule.

The Joint Committee on Agency Rule Review (JCARR) oversees agency rule making in Ohio. A hearing was held with JCARR on January 25, 2022 where these rules were placed on the consent agenda as item 36 (Attachment D1). On February 14, 2022, OAC rule 3745-21-09 was re-filed to make minor clarifications. Another

JCARR hearing for this rule was held on March 8, 2022 where this rule was placed on the consent agenda as item 45 (Attachment D2). No testimony, questions or invalidation of the rules occurred during either hearings. JCARR jurisdiction expired on February 2, 2022 for all rules except for OAC 3745-21-09 which expired on March 16, 2022, as evidenced by the JCARR consent agendas.

Ohio EPA issued the order to adopt the rules on March 17, 2022 as evidenced by the Director's Findings & Orders and the Public Notice (both contained in Article 2). The Secretary of the State and Director of the LSC once again received a letter of notice (Attachment E).

5. ORC 119.03(E): Provide notice to public prior to effective date of rules.

Ohio EPA provided an update of the adoption of the rules through the Ohio EPA website and through an e-mail notice to all interested parties on March 17, 2022. A copy of these notifications can be provided upon request.

ORC 121.39, Provisions applicable to proposed legislation or administrative rules concerning environmental protection, imposes further requirements for interested party review specific to environmental rule adoption. Ohio EPA fully complied with the requirements of this law and has provided evidence on the major requirements below:

1. ORC 121.39(B): Legislation dealing with the environment must be accompanied by a statement identifying if it is necessary to comply with a federal requirement. It must also include information on the estimated cost of compliance.

The RSFA and Environmental Rule Adoption/Amendment Form (ERAF) documents are automatically generated questions that are part of the States electronic rule filing system (Attachment B). The questions are intended to address the items in ORC 121.39. As evidenced in Question 6 of the RSFA documents and item (C) of the ERAF for the rule, Ohio EPA stated the adoption of this rule, or a version as stringent as, is required by U.S. EPA. The RSFA documents also contain a section entitled Fiscal Analysis which addresses potential costs. Our responses met the requirements of this law as evidenced in the consent by JCARR who reviews these documents.

2. ORC 121.39(D): Prior to adopting any environmental rule, the agency must consult with interested parties, consider all documentation relevant to the need for the rule making, identify any need to adopt in order to maintain approval to administer a federal environmental law, and it must include an RSFA.

On May 17, 2021 Ohio EPA notified interested parties via e-mail of the draft rule language. A copy of the notification may be provided upon request. We provided a 32-day comment period closing June 18, 2021. The interested parties list included Ohio EPA, DAPC's general rule making list. A copy of the e-mail and interested party list will be provided upon request.

As evidenced in item (C) of the ERAF for each rule, Ohio EPA stated the adoption of

this rule is required in order to maintain approval to administer a federal environmental law.

As evidenced in item (A) of the ERAF for each rule, Ohio EPA identified that it considered all documentation relevant to the need for the rule making and identified those documents in list form.

Article III

Attachment A

Public Hearing Notice

Public Notice and Public Hearing
Ohio Environmental Protection Agency
Ohio Administrative Code (OAC) Chapter 3745-21, "Carbon Monoxide, Photochemically Reactive
Materials, Hydrocarbons, and Related Materials Standards"
Five-Year Rule Review and Reasonably Available Control Technology (RACT) for the Cincinnati and
Cleveland 2015 Ozone Moderate Nonattainment Areas

Notice is hereby given that the Ohio Environmental Protection Agency, Division of Air Pollution Control (DAPC) has performed a review of the above referenced rules primarily to satisfy the requirements of Section 106.03 and 106.031 of the Ohio Revised Code (five-year review). Upon review, Ohio EPA has determined that certain changes are needed and that all rules in the chapter remain necessary.

Ohio EPA has drafted revisions to OAC chapter 3745-21 to adopt mandatory Reasonably Available Control Technology (RACT) requirements for Cincinnati and Cleveland 2015 ozone nonattainment areas. The Cleveland and Cincinnati nonattainment areas are currently classified as marginal nonattainment for the 2015 ozone standard. The areas are required to meet the ozone standard by August 3, 2021, based on ozone monitoring data collected during the 2018-2020 ozone monitoring seasons, which extend from March 1 to October 31 each year.

The Cleveland and Cincinnati areas have failed to meet the ozone standard during the 2018-2020 ozone monitoring seasons as required and Ohio EPA anticipates that the areas will be reclassified to moderate nonattainment by U.S. EPA in accordance with the Clean Air Act (CAA). Reclassification to moderate nonattainment triggers additional CAA requirements, including VOC RACT requirements. This includes adoption of U.S. EPA Control Technique Guidelines (CTGs) as well as non-CTG VOC RACT for major stationary sources located in the moderate nonattainment areas. Some CTGs and non-CTG VOC RACT were previously adopted under prior ozone standards.

Ohio EPA is also amending these rules to address minor changes needed for clarification and Legislative Service Commission (LSC) formatting protocol.

Please see the rule synopsis, available electronically at the web address below, for a complete summary of the proposed rule amendments.

Pursuant to Section 121.39 of the Ohio Revised Code, DAPC was required to consult with interested parties affected by the rules before the Division formally adopts them. On May 17, 2021 these rules went out for a 30-day review by interested parties. Ohio EPA's responses to comments received is available electronically on Ohio EPA's website at the URL listed below.

Ohio EPA has also prepared a draft RACT State Implementation Plan (SIP) which will be submitted to U.S. EPA along with the above-mentioned rules. Ohio EPA is also seeking public comment on the draft RACT SIP.

Pursuant to Part D of Title I of the CAA, Ohio EPA is required to establish a SIP for the attainment and maintenance of the NAAQS. The above-mentioned rules and RACT SIP are a part of Ohio's SIP for attainment and maintenance of the 2015 ozone NAAQS and the proposed amendments and RACT SIP will be submitted to United States Environmental Protection Agency (U.S. EPA) as a modification of the SIP.

Ohio EPA will hold an in-person and virtual public hearing on the rules on **Monday, January 3, 2022 at**

10:00 AM. The in-person hearing will be at the same time and date and will be located at Ohio EPA, Suite 700, 50 W. Town Street, Columbus, Ohio 43215. During the hearing, the public may submit written comments on the record about the proposed rules. If participating virtually, comments may be submitted electronically and may be submitted verbally if participating in person.

To facilitate the scheduling of oral presentations, persons intending to give testimony in-person at the hearing should notify Cathryn Allen at the Ohio EPA Public Interest Center, cathryn.allen@epa.ohio.gov or (614) 644-2160.

Citizens who want to participate virtually must register in advance for the meeting at: <https://register.gotowebinar.com/register/8634946818248390926>

All interested persons are entitled to attend or be represented at the hearing and give written or oral comments on these rule changes and SIP revisions. All oral comments presented at the hearing, and all written statements submitted at the hearing or by the close of business on January 3, 2022 will be considered by Ohio EPA prior to final action on this rule and SIP revisions. Written statements submitted after January 3, 2022 may be considered as time and circumstances permit but will not be part of the official record of the hearing.

These rules and associated rulemaking documents are available on DAPC's Web page for electronic downloading. The URL is: <https://epa.ohio.gov/dapc/DAPCrules>.

Questions regarding accessing the web site should be directed to Paul Braun at 614-644-3734; other questions or comments about these rules or SIP revisions should be directed to Holly Kaloz at Ohio EPA, (614) 644-3632, holly.kaloz@epa.ohio.gov, or mailed to Holly Kaloz, Ohio EPA, Division Air Pollution Control, Lazarus Government Center, P.O. Box 1049, Columbus, Ohio 43216-1049.

Article III

Attachment B

Letter to Secretary of State
and Director of LSC



ELECTRONIC RULE-FILING SYSTEM

FILING OF OHIO ADMINISTRATIVE RULES AND RULE-RELATED DOCUMENTS

The Honorable Frank LaRose
Secretary of State
180 E. Broad St., 16th Floor
Columbus, OH 43215

Wendy Zhan, Director
Legislative Service Commission
77 South High St., 9th Floor
Columbus, OH 43215

Larry Wolpert, Director
Joint Committee on Agency Rule Review
77 South High St., Concourse Level
Columbus, OH 43215

It is hereby confirmed that the Ohio Environmental Protection Agency **original filed** the following rule(s) pursuant to section 119.03 of the Ohio Revised Code.

Package Number: 190335
File Date and Time: 11/29/2021 9:09 AM
Confirmation Number: 76f1a6f9eb1aa0fe89a488eac5417dc

ORIGINAL FILE

Rule Number	Type	FYR	CSI	JE Date	Eff Date	Next FYR	Tagline
3745-21-01	Amendment	Y	Y	02/02/2022			Definitions and incorporation by reference.
3745-21-04	Amendment	Y	Y	02/02/2022			Compliance time schedules.
3745-21-07	Amendment	Y	Y	02/02/2022			Control of emissions of organic materials from stationary sources (i.e., emissions that are not regulated by rule 3745-21-09, 3745-21-12 to 3745-21-16, or 3745-21-18 to 3745-21-29 of the Administrative Code).
3745-21-09	Amendment	Y	Y	02/02/2022			Control of emissions of volatile organic compounds from stationary sources and perchloroethylene from dry cleaning facilities.
3745-21-10	Amendment	Y	Y	02/02/2022			Compliance test methods and procedures.
3745-21-11	New	N	Y	02/02/2022			Reasonably available control technology studies for non-CTG sources in ozone nonattainment areas.
3745-21-15	Amendment	Y	Y	02/02/2022			Control of volatile organic compound emissions from wood furniture manufacturing operations.
3745-21-18	Amendment	Y	Y	02/02/2022			Commercial motor vehicle and mobile equipment refinishing operations.
3745-21-19	Amendment	Y	Y	02/02/2022			Control of volatile organic compound emissions from aerospace manufacturing and rework facilities.
3745-21-20	Amendment	Y	Y	02/02/2022			Control of volatile organic emissions from shipbuilding and ship repair operations (marine coatings).
3745-21-21	Amendment	Y	Y	02/02/2022			Storage of volatile organic liquids in fixed roof tanks and external floating roof tanks.
3745-21-22	Amendment	Y	Y	02/02/2022			Control of volatile organic compound emissions from offset lithographic printing and letterpress printing facilities.

Rule Number	Type	FYR	CSI	JE Date	Eff Date	Next FYR	Tagline
3745-21-23	Amendment	Y	Y	02/02/2022			Control of volatile organic compound emissions from industrial solvent cleaning operations.
3745-21-24	Amendment	Y	Y	02/02/2022			Flat wood paneling coatings.
3745-21-25	Amendment	Y	Y	02/02/2022			Control of VOC emissions from reinforced plastic composites production operations.
3745-21-26	Amendment	Y	Y	02/02/2022			Surface coating of miscellaneous metal and plastic parts.
3745-21-27	Amendment	Y	Y	02/02/2022			Boat manufacturing.
3745-21-28	Amendment	Y	Y	02/02/2022			Miscellaneous industrial adhesives and sealants.
3745-21-29	Amendment	Y	Y	02/02/2022			Control of volatile organic compound emissions from automobile and light-duty truck assembly coating operations, heavier vehicle assembly coating operations, and cleaning operations associated with these coating operations.



ELECTRONIC RULE-FILING SYSTEM

FILING OF OHIO ADMINISTRATIVE RULES AND RULE-RELATED DOCUMENTS

The Honorable Frank LaRose
Secretary of State
180 E. Broad St., 16th Floor
Columbus, OH 43215

Wendy Zhan, Director
Legislative Service Commission
77 South High St., 9th Floor
Columbus, OH 43215

Larry Wolpert, Director
Joint Committee on Agency Rule Review
77 South High St., Concourse Level
Columbus, OH 43215

It is hereby confirmed that the Ohio Environmental Protection Agency **revise filed** the following rule(s) pursuant to section 119.03 of the Ohio Revised Code.

Package Number: 190335
File Date and Time: 11/29/2021 10:47 AM
Confirmation Number: cad8dbaaa4cc95e1d199116acd30a6e

REVISE

Rule Number	Type	FYR	CSI	JE Date	Eff Date	Next FYR	Tagline
3745-21-01	Amendment	Y	Y	02/02/2022			Definitions and incorporation by reference.
3745-21-04	Amendment	Y	Y	02/02/2022			Compliance time schedules.
3745-21-07	Amendment	Y	Y	02/02/2022			Control of emissions of organic materials from stationary sources (i.e., emissions that are not regulated by rule 3745-21-09, 3745-21-12 to 3745-21-16, or 3745-21-18 to 3745-21-29 of the Administrative Code).
3745-21-09	Amendment	Y	Y	02/02/2022			Control of emissions of volatile organic compounds from stationary sources and perchloroethylene from dry cleaning facilities.
3745-21-10	Amendment	Y	Y	02/02/2022			Compliance test methods and procedures.
3745-21-11	New	N	Y	02/02/2022			Reasonably available control technology studies for non-CTG sources in ozone nonattainment areas.
3745-21-15	Amendment	Y	Y	02/02/2022			Control of volatile organic compound emissions from wood furniture manufacturing operations.
3745-21-18	Amendment	Y	Y	02/02/2022			Commercial motor vehicle and mobile equipment refinishing operations.
3745-21-19	Amendment	Y	Y	02/02/2022			Control of volatile organic compound emissions from aerospace manufacturing and rework facilities.
3745-21-20	Amendment	Y	Y	02/02/2022			Control of volatile organic emissions from shipbuilding and ship repair operations (marine coatings).
3745-21-21	Amendment	Y	Y	02/02/2022			Storage of volatile organic liquids in fixed roof tanks and external floating roof tanks.
3745-21-22	Amendment	Y	Y	02/02/2022			Control of volatile organic compound emissions from offset lithographic printing and letterpress printing facilities.

Rule Number	Type	FYR	CSI	JE Date	Eff Date	Next FYR	Tagline
3745-21-23	Amendment	Y	Y	02/02/2022			Control of volatile organic compound emissions from industrial solvent cleaning operations.
3745-21-24	Amendment	Y	Y	02/02/2022			Flat wood paneling coatings.
3745-21-25	Amendment	Y	Y	02/02/2022			Control of VOC emissions from reinforced plastic composites production operations.
3745-21-26	Amendment	Y	Y	02/02/2022			Surface coating of miscellaneous metal and plastic parts.
3745-21-27	Amendment	Y	Y	02/02/2022			Boat manufacturing.
3745-21-28	Amendment	Y	Y	02/02/2022			Miscellaneous industrial adhesives and sealants.
3745-21-29	Amendment	Y	Y	02/02/2022			Control of volatile organic compound emissions from automobile and light-duty truck assembly coating operations, heavier vehicle assembly coating operations, and cleaning operations associated with these coating operations.



ELECTRONIC RULE-FILING SYSTEM

FILING OF OHIO ADMINISTRATIVE RULES AND RULE-RELATED DOCUMENTS

The Honorable Frank LaRose
Secretary of State
180 E. Broad St., 16th Floor
Columbus, OH 43215

Wendy Zhan, Director
Legislative Service Commission
77 South High St., 9th Floor
Columbus, OH 43215

Larry Wolpert, Director
Joint Committee on Agency Rule Review
77 South High St., Concourse Level
Columbus, OH 43215

It is hereby confirmed that the Ohio Environmental Protection Agency **refiled** the following rule(s) pursuant to section 119.03 of the Ohio Revised Code.

Package Number: 190335
File Date and Time: 02/14/2022 9:31 AM
Confirmation Number: 152825e5fcad4de1c356f551562

REFILE

Rule Number	Type	FYR	CSI	JE Date	Eff Date	Next FYR	Tagline
3745-21-09	Amendment	Y	Y	03/16/2022			Control of emissions of volatile organic compounds from stationary sources and perchloroethylene from dry cleaning facilities.

Article III
Attachment C
RSFAs

Rule Summary and Fiscal Analysis

Part A - General Questions

Rule Number: 3745-21-01

Rule Type: Amendment

Rule Title/Tagline: Definitions and incorporation by reference.

Agency Name: Ohio Environmental Protection Agency

Division:

Address: 50 West Town Street, Suite 700 PO Box 1049 Columbus OH 43216-1049

Contact: Holly Kaloz **Phone:** 614-644-2760

Email: holly.kaloz@epa.ohio.gov

I. Rule Summary

1. **Is this a five year rule review?** Yes
 - A. **What is the rule's five year review date?** 11/29/2021
2. **Is this rule the result of recent legislation?** No
3. **What statute is this rule being promulgated under?** 119.03
4. **What statute(s) grant rule writing authority?** 3704.03(E)
5. **What statute(s) does the rule implement or amplify?** 3704.03(A), 3704.03(E)
6. **What are the reasons for proposing the rule?**

This rule is being filed to fulfill the requirements of ORC 106.03 (5-yr review).

7. **Summarize the rule's content, and if this is an amended rule, also summarize the rule's changes.**

This rule defines the various terms used throughout Chapter 3745-21 of the Administrative Code. This rule is being amended to include information on items incorporated by reference and to add and modify definitions as necessary due to modifications elsewhere in Chapter 3745-21 of the Administrative Code. Minor

typographical changes have also been made to conform to LSC style and formatting guidelines.

- 8. Does the rule incorporate material by reference? Yes**
- 9. If the rule incorporates material by reference and the agency claims the material is exempt pursuant to R.C. 121.75, please explain the basis for the exemption and how an individual can find the referenced material.**

This rule contains references to the Ohio Administrative Code (OAC). While copies of these rules and statutes are generally available to the public through libraries and on-line sources, including the Ohio EPA website, ORC 121.76 (A) exempts such references from the provisions of ORC 121.71 through 121.75.

This rule also contains references to the Code of Federal Regulations (CFR). These rules are generally available through libraries, Ohio EPA and U.S. EPA websites. CFR references have also been dated to reference the specific version of the rules. ORC 121.75 (D) exempts such references from the requirements of ORC 121.71 through 121.74.

This rule also contains references to the United States Code (USC), the Federal Insecticide, Rodenticide, and Fungicide Act, and the Clean Air Act. These rules and Acts are generally available through libraries, Ohio EPA and Government Printing Office's websites. USC references have also been dated to reference the specific version of the rules. ORC 121.75(D) exempts such references from the requirements of ORC 121.71 through 121.74.

The rule also contains references to analytical test methods used to determine parameters for materials subject to this rule or other materials utilized by regulators and impacted parties to determine or achieve compliance with these rules. These test methods and materials are commonly known and utilized by laboratories performing this type of analytical work. Copies of these test methods are available in libraries and the websites of the method's supporting organization (ASTM, ANSI, NFPA, NACE, etc.).

Referenced materials are cited, dated and availability noted in paragraph (JJ) of rule 3745-21-01 of the Administrative Code.

- 10. If revising or re-filing the rule, please indicate the changes made in the revised or re-filed version of the rule.**

Ohio EPA's website is converting to the State of Ohio IOP platform during the comment period for this rule-making, therefore the link to the rules in the public notice would

no longer work. Ohio EPA is revise filing to change the public notice to the updated web location.

II. Fiscal Analysis

11. **Please estimate the increase / decrease in the agency's revenues or expenditures in the current biennium due to this rule.**

This will have no impact on revenues or expenditures.

0.00

Not Applicable

12. **What are the estimated costs of compliance for all persons and/or organizations directly affected by the rule?**

This rule contains definitions used throughout this chapter. There is no cost of compliance associated with this rule.

13. **Does the rule increase local government costs? (If yes, you must complete an RSFA Part B).** No

14. **Does the rule regulate environmental protection? (If yes, you must complete an RSFA Part C).** Yes

15. **If the rule imposes a regulation fee, explain how the fee directly relates to your agency's cost in regulating the individual or business.**

Not Applicable

III. Common Sense Initiative (CSI) Questions

16. **Was this rule filed with the Common Sense Initiative Office?** Yes

17. **Does this rule have an adverse impact on business?** No

A. **Does this rule require a license, permit, or any other prior authorization to engage in or operate a line of business?** No

B. **Does this rule impose a criminal penalty, a civil penalty, or another sanction, or create a cause of action, for failure to comply with its terms?** No

- C. Does this rule require specific expenditures or the report of information as a condition of compliance? No
- D. Is it likely that the rule will directly reduce the revenue or increase the expenses of the lines of business of which it will apply or applies? No

IV. Regulatory Restrictions (This section only applies to agencies indicated in R.C. 121.95 (A))

18. Are you adding a new or removing an existing regulatory restriction as defined in R.C. 121.95? Yes
- A. How many new regulatory restrictions do you propose adding? 0
 - B. How many existing regulatory restrictions do you propose removing? 33

Removed restriction: OAC 3745-21-01(A): Except as otherwise provided in this rule, the definitions in rule 3745-15-01 of the Administrative Code shall apply to this chapter. (removed shall)

Removed restriction: OAC 3745-21-01(C)(5)(c): Revised "Whenever any organic material or any constituent of an organic material may be classified from its chemical structure into more than one of the above groups of organic compounds, it shall be considered as a member of the most reactive chemical group, that is, that group having the least allowable per cent of the total volume of liquid." to "Any organic material or any constituent of an organic material that may be classified from its chemical structure into more than one of the above groups of organic compounds, is considered as a member of the most reactive chemical group, that is, that group having the least allowable per cent of the total volume of liquid."

Removed restriction: OAC 3745-21-01(C)(6): "Submerged fill pipe" means any fill pipe with the discharge opening entirely submerged when the liquid level is six inches above the bottom of the tank; or when applied to a tank which is loaded from the side, shall mean any fill pipe with the discharge opening entirely submerged when the liquid level is eighteen inches above the bottom of the tank. (changed "shall mean" to "means")

Removed restriction: OAC 3745-21-01(D)(53): "Coating of plastic parts of automobiles and trucks" means the coating of any plastic part that is or shall

will be assembled with other parts to form an automobile or truck. (changed shall to will)

Removed restriction: OAC 3745-21-01(D)(54): "Coating of plastic parts of business machines" means the coating of any plastic part that is or shall will be assembled with other parts to form a business machine. (changed shall to will)

Removed restriction: OAC 3745-21-01(D)(86): "Fog coating" means a coating is applied to a plastic part for the purpose of color matching without masking a molded-in texture. A fog coat shall not be applied at a thickness of more than 0.5 mils of coating solids. Changed to "Fog coating" means a coating is applied to a plastic part for the purpose of color matching without masking a molded-in texture and that is not applied at a thickness of more than 0.5 mils of coating solids.

Removed restriction: OAC 3745-21-01(D)(89)(b): For miscellaneous industrial adhesives and sealants, a coating that is applied to a plastic part solely to reduce the shine of the part and such gloss reducer shall not be applied at a thickness of more than 0.5 mils of coating solids. Changed to For miscellaneous industrial adhesives and sealants glossreducer means a coating that is applied at a thickness of no more than 0.5 mils of coating solids to a plastic part solely to reduce the shine of the part.

Removed restriction: OAC 3745-21-01(D)(186): "Vinyl coating" means a coating or ink applied to the surface of vinyl coated fabric, vinyl sheets, or other vinyl products by means of a knife coater, roll coater, or roll printer. For purposes of this rule, "vinyl coating" shall not include organisol or plastisol coatings. Changed to "Vinyl coating" means a coating or ink, not including organisol or plastisol coatings, applied to the surface of vinyl coated fabric, vinyl sheets, or other vinyl products by means of a knife coater, roll coater, or roll printer.

Removed restriction: OAC 3745-21-01(H)(4)(a)(i): however, gasoline dispensing facilities in Ohio shall not be subject to any provision or statement that specifies an expiration or decertification due to EVR standards and certification procedures. (replaced "shall not be" with "are not").

Removed restriction: OAC 3745-21-01(H)(4)(a)(ii): however, gasoline dispensing facilities in Ohio shall not be subject to any provision or statement that specifies an expiration or decertification due to EVR standards and certification procedures. (replaced "shall not be" with "are not").

Removed restriction: OAC 3745-21-01(H)(4)(a)(ii): "CARB certification" and "CARB certified" shall also mean (replaced "shall also mean" with "also means")

Removed restriction: OAC 3745-21-01(H)(12)(d): For purposes of this definition, the term "refiner" shall not include (replaced "shall not include" with "means")

Removed restriction: OAC 3745-21-01(H)(16): "Submerged fill pipe" means any fill pipe the discharge opening of which is entirely submerged when the liquid level is six inches above the bottom of the tank, or when applied to a tank which is loaded from the side, shall mean (replaced "shall mean" with "means")

Removed restriction: OAC 3745-21-01(U): Except as otherwise provided in this paragraph, the definitions in rule 3745-15-01 of the Administrative Code and paragraph (B) of rule 3745-21-01 of the Administrative Code shall apply to rule 3745-21-12 (removed shall)

Removed restriction: OAC 3745-21-01(U)(8): Any physical or operational limitation on the capacity shall be treated as part of its physical and operational design (replaced "shall be" with "are").

Removed restriction: OAC 3745-21-01(V): Except as otherwise provided in this paragraph, the definitions in rule 3745-15-01 of the Administrative Code and paragraph (B) of this rule shall apply to rule 3745-21-13 (removed shall)

Removed restriction: OAC 3745-21-01(W): Except as otherwise provided in this paragraph, the definitions in rule 3745-15-01 of the Administrative Code and paragraph (B) of this rule shall apply to rule 3745-21-14 (removed shall)

Removed restriction: OAC 3745-21-01(W)(4): Irrespective of the product being produced, a batch process train which is independent of other processes shall be considered a single batch process train for purposes of this rule. (changed "shall be" to "is")

Removed restriction: OAC 3745-21-01(W)(8): "Emission event" shall be defined as a discrete period of venting that is associated with a unit operation (changed "shall be defined as" to "means")

Removed restriction: OAC 3745-21-01(X): Except as otherwise provided in this paragraph, the definitions in rule 3745-15-01 of the Administrative Code and paragraph (B) of this rule shall apply to rule 3745-21-15 (removed shall)

Removed restriction: OAC 3745-21-01(X)(1): "Adhesive" means any chemical substance that is applied for the purpose of bonding two surfaces together other than by mechanical means. Products used on humans and animals, adhesive tape, contact paper, or any other product with an adhesive incorporated onto or in an inert substrate shall not be considered adhesives. Changed to "Adhesive" means any chemical substance that is applied for the purpose of bonding two surfaces together other than by mechanical mean but does not include products used on humans and animals, adhesive tape, contact paper, or any other product with an adhesive incorporated onto or in an inert substrate.

Removed restriction: OAC 3745-21-01(X)(24): "Finishing material" means a coating used in the wood furniture manufacturing industry. Such materials include, but are not limited to, stains, basecoats, washcoats, enamels, sealers, and topcoats. Under rule 3745-21-15 of the Administrative Code, adhesives and nonpermanent final finish materials shall not be considered finishing materials. Changed to "Finishing material" means a coating used in the wood furniture manufacturing industry. Such materials include, but are not limited to, stains, basecoats, washcoats, enamels, sealers, and topcoats except that adhesives and nonpermanent final finish materials are not included under rule 3745-21-15 of the Administrative Code.

Removed restriction: OAC 3745-21-01(Y): Except as otherwise provided in this paragraph, the definitions in rule 3745-15-01 of the Administrative Code and paragraph (B) of this rule shall apply to rule 3745-21-16 (removed shall)

Removed restriction: OAC 3745-21-01(Z): Except as otherwise provided in this paragraph, the definitions in rule 3745-15-01 of the Administrative Code and paragraph (B) of this rule shall apply to rule 3745-21-17 (removed shall)

Removed restriction: OAC 3745-21-01(AA)(13): A material shall not be classified as a bearing coating if (changed "shall not be" to "but is not")

Removed restriction: OAC 3745-21-01(AA)(15): "Caulking and smoothing compounds" means semi-solid materials which are applied by hand application methods and are used to aerodynamically smooth exterior vehicle surfaces or fill cavities such as bolt hole accesses. A material shall not be classified as a caulking and smoothing compound if the material can also be classified as a sealant. Changed to "Caulking and smoothing compounds" means semi-solid materials which are applied by hand application methods and are used to aerodynamically smooth exterior vehicle surfaces or fill cavities such as bolt

hole accesses, but does not include materials that may also be classified as a sealant.

Removed restriction: OAC 3745-21-01(BB)(13): "Pleasure craft" means any marine or fresh-water vessel used by individuals for noncommercial, nonmilitary, and recreational purposes that is less than twenty meters in length. A vessel rented exclusively to or chartered by individuals for such purposes shall be considered a pleasure craft. Changed to "Pleasure craft" means any marine or fresh-water vessel used by individuals for noncommercial, nonmilitary, and recreational purposes that is less than twenty meters in length including vessels rented exclusively to or chartered by individuals for such purposes.

Removed restriction: OAC 3745-21-01(GG)(40)(a): The products shall meet both the applicable flame spread requirements and the applicable smoke requirements. (removed "shall meet")

Removed restriction: OAC 3745-21-01(GG)(40)(b): Interior or exterior building application products shall meet an ASTM... (removed "shall meet")

Removed restriction: OAC 3745-21-01(GG)(40)(c): Mass transit application products shall meet an ASTM... (removed "shall meet")

Removed restriction: OAC 3745-21-01(GG)(40)(d): Duct application products shall meet an ASTM... (removed "shall meet")

Removed restriction: OAC 3745-21-01(GG)(51): In addition, the device shall be is operated according to the manufacturer's directions (replaced "shall be" with "is")

Removed restriction: OAC 3745-21-01(GG)(54): and the manufacturing schedule shall be based on (removed "shall be")

Rule Summary and Fiscal Analysis

Part C - Environmental Rule Questions

Pursuant to Am. Sub. H.B. 106 of the 121st General Assembly, prior to adopting a rule or an amendment to a rule dealing with environmental protection, or containing a component dealing with environmental protection, a state agency shall:

- (1) Consult with organizations that represent political subdivisions, environmental interests, business interests, and other persons affected by the proposed rule or amendment.
- (2) Consider documentation relevant to the need for, the environmental benefits or consequences of, other benefits of, and the technological feasibility of the proposed rule or rule amendment.
- (3) Specifically identify whether the proposed rule or rule amendment is being adopted or amended to enable the state to obtain or maintain approval to administer and enforce a federal environmental law or to participate in a federal environmental program, whether the proposed rule or rule amendment is more stringent than its federal counterpart, and, if the proposed rule or rule amendment is more stringent, the rationale for not incorporating its federal counterpart.
- (4) Include with the proposed rule or rule amendment and rule summary and fiscal analysis required to be filed with the Joint Committee on Agency Rule Review information relevant to the previously listed requirements.

(A) Were organizations that represent political subdivisions, environmental interests, business interests, and other persons affected by the proposed rule or amendment consulted? Yes

Please list each contact.

A draft of these rules was released for a 30-day public comment and review period ending June 18, 2021. The rules were released to Ohio EPA's electronic interested parties list, posted on Ohio EPA's regulations website and shared with interested industry parties. Several comments were received on Ohio EPA's rulemaking effort. Ohio EPA's response to comments document can be provided upon request. A copy of Ohio EPA's interested parties distribution list can be made available upon request.

(B) Was documentation that is relevant to the need for, the environmental benefits or consequences of, other benefits of, and the technological feasibility of the proposed rule or amendment considered? Yes

Please list the information provided and attach a copy of each piece of documentation to this form. (A SUMMARY OR INDEX MAY BE ATTACHED IN LIEU OF THE ACTUAL DOCUMENTATION.)

Clean Air Act, USEPA Control Technique Guidance Documents, LSC Style and Formatting Manual, and comments from interested parties.

- (C) **Is the proposed rule or rule amendment being adopted or amended to enable the state to obtain or maintain approval to administer and enforce a federal environmental law or to participate in a federal environmental program? Yes**

Is the proposed rule or rule amendment more stringent than its federal counterpart?
No Not Applicable

- (D) **If this is a rule amendment that is being adopted under a state statute that establishes standards with which the amendment is to comply, is the proposed rule amendment more stringent than the rule that it is proposing to amend? No**

Rule Summary and Fiscal Analysis

Part A - General Questions

Rule Number: 3745-21-04

Rule Type: Amendment

Rule Title/Tagline: Compliance time schedules.

Agency Name: Ohio Environmental Protection Agency

Division:

Address: 50 West Town Street, Suite 700 PO Box 1049 Columbus OH 43216-1049

Contact: Holly Kaloz **Phone:** 614-644-2760

Email: holly.kaloz@epa.ohio.gov

I. Rule Summary

1. **Is this a five year rule review? Yes**
 - A. **What is the rule's five year review date? 11/29/2021**
2. **Is this rule the result of recent legislation? No**
3. **What statute is this rule being promulgated under? 119.03**
4. **What statute(s) grant rule writing authority? 3704.03(E)**
5. **What statute(s) does the rule implement or amplify? 3704.03(A), 3704.03(E)**
6. **What are the reasons for proposing the rule?**

This rule is being filed to fulfill the requirements of ORC 106.03 (5-yr review) and to adopt mandatory Reasonably Available Control Technology (RACT) requirements for the Cincinnati and Cleveland 2015 ozone nonattainment areas.

7. **Summarize the rule's content, and if this is an amended rule, also summarize the rule's changes.**

This rule establishes the compliance time schedules for emission reduction and control requirements for sources subject to Chapter 3745-21 of the Administrative Code. Amendments pursuant to the 5-year review are being made to correct formatting

to meet LSC requirements, to update facility names and addresses, to remove permanently closed facilities, and to remove unnecessary restriction language from the rule. In addition, amendments are being made to establish compliance deadlines for the expansion of requirements to the Cincinnati nonattainment area.

8. **Does the rule incorporate material by reference? Yes**
9. **If the rule incorporates material by reference and the agency claims the material is exempt pursuant to R.C. 121.75, please explain the basis for the exemption and how an individual can find the referenced material.**

This rule contains references to the Ohio Administrative Code (OAC). While copies of these rules and statutes are generally available to the public through libraries and on-line sources, including the Ohio EPA website, ORC 121.76 (A) exempts such references from the provisions of ORC 121.71 through 121.75.

This rule also contains references to the Code of Federal Regulations (CFR). These rules are generally available through libraries, Ohio EPA and U.S. EPA websites. CFR references have also been dated to reference the specific version of the rules. ORC 121.75 (D) exempts such references from the requirements of ORC 121.71 through 121.74.

The rule also contains references to analytical test methods used to determine parameters for materials subject to this rule or other materials utilized by regulators and impacted parties to determine or achieve compliance with these rules. These test methods and materials are commonly known and utilized by laboratories performing this type of analytical work. Copies of these test methods are available in libraries and the websites of the method's supporting organization (ASTM, ANSI, NFPA, NACE, etc.).

Referenced materials are cited, dated and availability noted in paragraph (JJ) of rule 3745-21-01 of the Administrative Code.

10. **If revising or re-filing the rule, please indicate the changes made in the revised or re-filed version of the rule.**

Ohio EPA's website is converting to the State of Ohio IOP platform during the comment period for this rule-making, therefore the link to the rules in the public notice would no longer work. Ohio EPA is revise filing to change the public notice to the updated web location.

II. Fiscal Analysis

11. Please estimate the increase / decrease in the agency's revenues or expenditures in the current biennium due to this rule.

This will have no impact on revenues or expenditures.

0.00

Not Applicable

12. What are the estimated costs of compliance for all persons and/or organizations directly affected by the rule?

This rule establishes the compliance requirements and time schedules for emission reduction and control requirements for sources subject to Chapter 3745-21 of the Administrative Code. This rule requires facilities subject to this chapter to provide a written certification that they are in compliance with the requirements of this chapter and apply for a permit-to-install and operate for the subject sources in accordance with OAC Chapter 3745-31 or a permit-to-operate in accordance with OAC Chapter 3745-77.

The cost of compliance to apply for and obtain a permit-to-install or a permit-to-install and operate varies greatly based on the size and number of sources at the facility. For example, a small facility subject, such as a dry-cleaning facility, which are eligible for a permit-by-rule may only incur a cost of compliance of a few hundred dollars to generate a letter to Ohio EPA requesting their permit, whereas a large manufacturing facility with multiple sources may spend a few thousand to \$35,000 to prepare their application and complete the process. Permits are necessary to assure that facilities are aware of and can operate within the allowable emission limits contained in this chapter. The cost of the compliance letter is included in these costs.

13. Does the rule increase local government costs? (If yes, you must complete an RSFA Part B). No

14. Does the rule regulate environmental protection? (If yes, you must complete an RSFA Part C). Yes

15. If the rule imposes a regulation fee, explain how the fee directly relates to your agency's cost in regulating the individual or business.

Not Applicable

III. Common Sense Initiative (CSI) Questions

16. Was this rule filed with the Common Sense Initiative Office? Yes

17. Does this rule have an adverse impact on business? Yes

A. Does this rule require a license, permit, or any other prior authorization to engage in or operate a line of business? Yes

An affected facility is required to submit a notification to the Ohio EPA district office or local air agency in writing that states that the facility is subject to this rule. A new permit is required if the facility does not already possess a complying permit.

B. Does this rule impose a criminal penalty, a civil penalty, or another sanction, or create a cause of action, for failure to comply with its terms? No

C. Does this rule require specific expenditures or the report of information as a condition of compliance? No

D. Is it likely that the rule will directly reduce the revenue or increase the expenses of the lines of business of which it will apply or applies? No

IV. Regulatory Restrictions (This section only applies to agencies indicated in R.C. 121.95 (A))

18. Are you adding a new or removing an existing regulatory restriction as defined in R.C. 121.95? Yes

A. How many new regulatory restrictions do you propose adding? 8

New restriction: OAC 3745-21-04(C)(3)(c): Paragraphs (C)(5)(f), (C)(8)(g), (C)(10)(f), and (C)(32)(c) of this rule, a certification or operating permit application shall be submitted in accordance with paragraphs (B)(1)(a) and (B)(1)(b) of this rule by no later than sixty days after the effective date of this rule.

Removed restriction 1: OAC 3745-21-01(A): Except as otherwise provided in this rule, the definitions in rule 3745-15-01 of the Administrative Code shall apply to this chapter. (removed shall)

Removed restriction 2: OAC 3745-21-01(C)(5)(c): Revised "Whenever any organic material or any constituent of an organic material may be classified

from its chemical structure into more than one of the above groups of organic compounds, it shall be considered as a member of the most reactive chemical group, that is, that group having the least allowable per cent of the total volume of liquid." to "Any organic material or any constituent of an organic material that may be classified from its chemical structure into more than one of the above groups of organic compounds, is considered as a member of the most reactive chemical group, that is, that group having the least allowable per cent of the total volume of liquid."

New restriction: OAC 3745-21-04(C)(5)(e): Any owner or operator of a paper coating line located in Butler, Clermont, Hamilton or Warren county which is subject to paragraph (F)(2) of rule 3745-21-09 of the Administrative Code shall achieve compliance with said requirements by no later than March 1, 2023.

Removed restriction 1: OAC 3745-21-01(C)(6): "Submerged fill pipe" means any fill pipe with the discharge opening entirely submerged when the liquid level is six inches above the bottom of the tank; or when applied to a tank which is loaded from the side, shall mean any fill pipe with the discharge opening entirely submerged when the liquid level is eighteen inches above the bottom of the tank. (changed "shall mean" to "means")

Removed restriction 2: OAC 3745-21-01(D)(53): "Coating of plastic parts of automobiles and trucks" means the coating of any plastic part that is or shall will be assembled with other parts to form an automobile or truck. (changed shall to will)

New restriction: OAC 3745-21-04(C)(5)(f): Any owner or operator of a paper coating line located in Butler, Clermont, Hamilton or Warren county which employs an add-on control system shall achieve compliance with the control requirements specified in paragraph (B)(7) of rule 3745-21-09 of the Administrative Code by no later than March 1, 2023.

Removed restriction 1: OAC 3745-21-01(D)(54): "Coating of plastic parts of business machines" means the coating of any plastic part that is or shall will be assembled with other parts to form a business machine. (changed shall to will)

Removed restriction 2: OAC 3745-21-01(D)(86): "Fog coating" means a coating is applied to a plastic part for the purpose of color matching without masking a molded-in texture. A fog coat shall not be applied at a thickness of more than 0.5 mils of coating solids. Changed to "Fog coating" means a coating is applied to a plastic part for the purpose of color matching without masking a molded-

in texture and that is not applied at a thickness of more than 0.5 mils of coating solids.

New restriction: OAC 3745-21-04(C)(8)(f): Any owner or operator of a metal furniture coating line located in Butler, Clermont, Hamilton or Warren county which is subject to paragraph (I)(4) of rule 3745-21-09 of the Administrative Code shall achieve compliance with said requirements by no later than March 1, 2023.

Removed restriction 1: OAC 3745-21-01(D)(89)(b): For miscellaneous industrial adhesives and sealants, a coating that is applied to a plastic part solely to reduce the shine of the part and such gloss reducer shall not be applied at a thickness of more than 0.5 mils of coating solids. Changed to For miscellaneous industrial adhesives and sealants glossreducer means a coating that is applied at a thickness of no more than 0.5 mils of coating solids to a plastic part solely to reduce the shine of the part.

Removed restriction 2: OAC 3745-21-01(D)(186): "Vinyl coating" means a coating or ink applied to the surface of vinyl coated fabric, vinyl sheets, or other vinyl products by means of a knife coater, roll coater, or roll printer. For purposes of this rule, "vinyl coating" shall not include organisol or plastisol coatings. Changed to "Vinyl coating" means a coating or ink, not including organisol or plastisol coatings, applied to the surface of vinyl coated fabric, vinyl sheets, or other vinyl products by means of a knife coater, roll coater, or roll printer.

New restriction: OAC 3745-21-04(C)(8)(g): Any owner or operator of a metal furniture coating line located in Butler, Clermont, Hamilton or Warren county which employs an add-on control system shall achieve compliance with either the control requirements specified in paragraph (B)(7) of rule 3745-21-09 of the Administrative Code or the VOC limitation specified in the table of paragraph (I)(4) of rule 3745-21-09 of the Administrative Code and expressed in terms of pounds of VOC per gallon of deposited solids by no later than March 1, 2023.

Removed restriction 1: OAC 3745-21-01(H)(4)(a)(i): however, gasoline dispensing facilities in Ohio shall not be subject to any provision or statement that specifies an expiration or decertification due to EVR standards and certification procedures. (replaced "shall not be" with "are not").

Removed restriction 2: OAC 3745-21-01(H)(4)(a)(ii): however, gasoline dispensing facilities in Ohio shall not be subject to any provision or statement

that specifies an expiration or decertification due to EVR standards and certification procedures. (replaced "shall not be" with "are not").

New restriction: OAC 3745-21-04(C)(10)(e): Any owner or operator of a large appliance coating line located in Butler, Clermont, Hamilton or Warren county which is subject to paragraph (K)(6) of rule 3745-21-09 of the Administrative Code shall achieve compliance with said requirements by no later than March 1, 2023.

Removed restriction 1: OAC 3745-21-01(H)(4)(a)(ii): "CARB certification" and "CARB certified" shall also mean (replaced "shall also mean" with "also means")

Removed restriction 2: OAC 3745-21-01(H)(12)(d): For purposes of this definition, the term "refiner" shall not include (replaced "shall not include" with "means")

New restriction: OAC 3745-21-04(C)(10)(f): Any owner or operator of a large appliance coating line located in Butler, Clermont, Hamilton or Warren county which employs a control system shall achieve compliance with either the control requirements specified in paragraph (B)(7) of rule 3745-21-09 of the Administrative Code or the VOC limitation which is contained in paragraph (K) (6) of rule 3745-21-09 of the Administrative Code and expressed in terms of pounds of VOC per gallon of deposited solids by no later than March 1, 2023.

Removed restriction 1: OAC 3745-21-01(H)(16): "Submerged fill pipe" means any fill pipe the discharge opening of which is entirely submerged when the liquid level is six inches above the bottom of the tank, or when applied to a tank which is loaded from the side, shall mean (replaced "shall mean" with "means")

Removed restriction 2: OAC 3745-21-01(U): Except as otherwise provided in this paragraph, the definitions in rule 3745-15-01 of the Administrative Code and paragraph (B) of rule 3745-21-01 of the Administrative Code shall apply to rule 3745-21-12 (removed shall)

New restriction: OAC 3745-21-04(C)(32)(c): Paragraph (Y)(4) of rule 3745-21-09 of the Administrative Code shall achieve compliance with said requirements by no later than March 1, 2023 for a packaging rotogravure printing line, publication rotogravure printing line, or flexographic printing line located in Butler, Clermont, Hamilton or Warren county.

Removed restriction 1: OAC 3745-21-01(U)(8): Any physical or operational limitation on the capacity ... shall be treated as part of its physical and operational design if... (replaced "shall be" with "are")

Removed restriction 2: OAC 3745-21-01(V): Except as otherwise provided in this paragraph, the definitions in rule 3745-15-01 of the Administrative Code and paragraph (B) of this rule shall apply to rule 3745-21-13 (removed shall)

B. How many existing regulatory restrictions do you propose removing? 7

Removed restriction: OAC 3745-21-04(B)(1)(a): Such certification shall include: equipment description, Ohio EPA permit application number (if assigned), and all necessary data (consistent with the appropriate permit application appendices or emission activity category forms) and calculations which confirm the compliance status. (changed to list form and changed "shall include" to "including the following")

Removed restriction: OAC 3745-21-04(B)(1)(a): The certification shall also include an application for a permit authorizing operation of such source in accordance with rule 3745-21-09 of the Administrative Code if such source does not possess an effective permit, or, if applicable. (moved to list form and removed "also shall")

Removed restriction: OAC 3745-21-04(B)(1)(b): Such application shall include... (changed "shall include" to "including")

Removed restriction: OAC 3745-21-04(B)(1)(b): ...and shall identify all reasonable interim control measures... (changed "shall identify" to "identifies")

Removed restriction: OAC 3745-21-04(B)(7): the owner or operator shall only submit (changed "shall only submit" to "an operating permit is not required")

Removed restriction: OAC 3745-21-04(C)(45): "PMC Cincinnati, Inc.", facility ID 1431380075, or any subsequent owner or operator of the "PMC Cincinnati, Inc." facility located at 2000 West street, Cincinnati, Ohio shall achieve compliance with paragraph (KK) of rule 3745-21-09 of the Administrative Code by May 25, 1988.

Removed restriction: OAC 3745-21-04(C)(53): "Ritrama Duramark", facility ID 1318007355, or any subsequent owner or operator of the "Ritrama Duramark" facility located at 341 Eddy Road, Cleveland, Ohio shall achieve compliance

with paragraph (SS) of rule 3745-21-09 of the Administrative Code by March 31, 1993.

Rule Summary and Fiscal Analysis

Part C - Environmental Rule Questions

Pursuant to Am. Sub. H.B. 106 of the 121st General Assembly, prior to adopting a rule or an amendment to a rule dealing with environmental protection, or containing a component dealing with environmental protection, a state agency shall:

- (1) Consult with organizations that represent political subdivisions, environmental interests, business interests, and other persons affected by the proposed rule or amendment.
- (2) Consider documentation relevant to the need for, the environmental benefits or consequences of, other benefits of, and the technological feasibility of the proposed rule or rule amendment.
- (3) Specifically identify whether the proposed rule or rule amendment is being adopted or amended to enable the state to obtain or maintain approval to administer and enforce a federal environmental law or to participate in a federal environmental program, whether the proposed rule or rule amendment is more stringent than its federal counterpart, and, if the proposed rule or rule amendment is more stringent, the rationale for not incorporating its federal counterpart.
- (4) Include with the proposed rule or rule amendment and rule summary and fiscal analysis required to be filed with the Joint Committee on Agency Rule Review information relevant to the previously listed requirements.

(A) Were organizations that represent political subdivisions, environmental interests, business interests, and other persons affected by the proposed rule or amendment consulted? Yes

Please list each contact.

A draft of these rules was released for a 30-day public comment and review period ending June 18, 2021. The rules were released to Ohio EPA's electronic interested parties list, posted on Ohio EPA's regulations website and shared with interested industry parties. Several comments were received on Ohio EPA's rulemaking effort. Ohio EPA's response to comments document can be provided upon request. A copy of Ohio EPA's interested parties distribution list can be made available upon request.

(B) Was documentation that is relevant to the need for, the environmental benefits or consequences of, other benefits of, and the technological feasibility of the proposed rule or amendment considered? Yes

Please list the information provided and attach a copy of each piece of documentation to this form. (A SUMMARY OR INDEX MAY BE ATTACHED IN LIEU OF THE ACTUAL DOCUMENTATION.)

Clean Air Act, USEPA Control Technique Guidance Documents, LSC Style and Formatting Manual, and comments from interested parties.

- (C) Is the proposed rule or rule amendment being adopted or amended to enable the state to obtain or maintain approval to administer and enforce a federal environmental law or to participate in a federal environmental program? Yes**

Is the proposed rule or rule amendment more stringent than its federal counterpart?
No Not Applicable

- (D) If this is a rule amendment that is being adopted under a state statute that establishes standards with which the amendment is to comply, is the proposed rule amendment more stringent than the rule that it is proposing to amend? No**

Rule Summary and Fiscal Analysis

Part A - General Questions

Rule Number: 3745-21-07

Rule Type: Amendment

Rule Title/Tagline: Control of emissions of organic materials from stationary sources (i.e., emissions that are not regulated by rule 3745-21-09, 3745-21-12 to 3745-21-16, or 3745-21-18 to 3745-21-29 of the Administrative Code).

Agency Name: Ohio Environmental Protection Agency

Division:

Address: 50 West Town Street, Suite 700 PO Box 1049 Columbus OH 43216-1049

Contact: Holly Kaloz **Phone:** 614-644-2760

Email: holly.kaloz@epa.ohio.gov

I. Rule Summary

1. **Is this a five year rule review?** Yes
 - A. **What is the rule's five year review date?** 11/29/2021
2. **Is this rule the result of recent legislation?** No
3. **What statute is this rule being promulgated under?** 119.03
4. **What statute(s) grant rule writing authority?** 3704.03(E)
5. **What statute(s) does the rule implement or amplify?** 3704.03(A), 3704.03(E)
6. **What are the reasons for proposing the rule?**

This rule is being filed to fulfill the requirements of ORC 106.03 (5-yr review).

7. **Summarize the rule's content, and if this is an amended rule, also summarize the rule's changes.**

This rule identifies control requirements for emissions of organic materials from stationary sources (i.e., emissions that are not regulated by rule 3745-21-09, 3745-21-12 to 3745-21-16, or 3745-21-18 to 3745-21-29 of the Administrative Code).

This rule is being amended to correct formatting to meet LSC requirements, to update facility names and addresses, to remove permanently closed facilities and units, and to remove unnecessary restriction language from the rule.

- 8. Does the rule incorporate material by reference? Yes**
- 9. If the rule incorporates material by reference and the agency claims the material is exempt pursuant to R.C. 121.75, please explain the basis for the exemption and how an individual can find the referenced material.**

This rule contains references to the Ohio Administrative Code (OAC). While copies of these rules and statutes are generally available to the public through libraries and on-line sources, including the Ohio EPA website, ORC 121.76 (A) exempts such references from the provisions of ORC 121.71 through 121.75.

This rule also contains references to the Code of Federal Regulations (CFR). These rules are generally available through libraries, Ohio EPA and U.S. EPA websites. CFR references have also been dated to reference the specific version of the rules. ORC 121.75 (D) exempts such references from the requirements of ORC 121.71 through 121.74.

This rule also contains references to the United States Code (USC) and the Clean Air Act. These rules and Acts are generally available through libraries, Ohio EPA and Government Printing Office's websites. USC references have also been dated to reference the specific version of the rules. ORC 121.75(D) exempts such references from the requirements of ORC 121.71 through 121.74.

Referenced materials are cited, dated and availability noted in paragraph (JJ) of rule 3745-21-01 of the Administrative Code.

- 10. If revising or re-filing the rule, please indicate the changes made in the revised or re-filed version of the rule.**

Ohio EPA's website is converting to the State of Ohio IOP platform during the comment period for this rule-making, therefore the link to the rules in the public notice would no longer work. Ohio EPA is revise filing to change the public notice to the updated web location.

II. Fiscal Analysis

- 11. Please estimate the increase / decrease in the agency's revenues or expenditures in the current biennium due to this rule.**

This will have no impact on revenues or expenditures.

0.00

Not Applicable

12. What are the estimated costs of compliance for all persons and/or organizations directly affected by the rule?

This rule has been in effect for several years. All costs associated with compliance with the existing requirements of this rule have been addressed in previous rulemakings and have been well established in the industry. The amendments being made to this rule do not add any additional requirements to affected facilities. As such, there is no additional cost of compliance associated with the amendments being made to this rule.

13. Does the rule increase local government costs? (If yes, you must complete an RSFA Part B). No

14. Does the rule regulate environmental protection? (If yes, you must complete an RSFA Part C). Yes

15. If the rule imposes a regulation fee, explain how the fee directly relates to your agency's cost in regulating the individual or business.

Not Applicable

III. Common Sense Initiative (CSI) Questions

16. Was this rule filed with the Common Sense Initiative Office? Yes

17. Does this rule have an adverse impact on business? No

A. Does this rule require a license, permit, or any other prior authorization to engage in or operate a line of business? No

B. Does this rule impose a criminal penalty, a civil penalty, or another sanction, or create a cause of action, for failure to comply with its terms? No

C. Does this rule require specific expenditures or the report of information as a condition of compliance? No

- D. Is it likely that the rule will directly reduce the revenue or increase the expenses of the lines of business of which it will apply or applies? No

IV. Regulatory Restrictions (This section only applies to agencies indicated in R.C. 121.95 (A))

18. Are you adding a new or removing an existing regulatory restriction as defined in R.C. 121.95? Yes

- A. How many new regulatory restrictions do you propose adding? 0
- B. How many existing regulatory restrictions do you propose removing? 32

Removed restriction: OAC 3745-21-07(A)(3): This rule shall apply to any source or operation, for which installation commenced prior to February 18, 2008 and that is specified in paragraphs (K) to (N) of this rule, but shall not apply to VOC emissions... (changed "shall not apply to" to "is not applicable to")

Removed restriction: OAC 3745-21-07(A)(4): Any emission limitation, control requirement, or operational restriction contained in a permit-to-install, permit-by-rule, permit-to-operate, or Title V permit that is based upon a citation to this rule, except the emission limitations and control requirements specified in paragraphs (K)(2), (K)(4), (L)(2), (M)(2) to (M)(4), (N)(2), and (N)(3) of this rule, shall be void upon February 18, 2008. (changed "shall be void upon" to "expire as of")

Removed restriction: OAC 3745-21-07(A)(4): As examples of the applicability of this paragraph, if a permit-to install, a permit-by-rule, a permit-to-operate, or a Title V permit has been issued prior to February 18, 2008 and contains both a citation to rule 3745-21-07 of the Administrative Code and one of the associated requirements referenced within this comment, the associated requirements contained in such a permit shall be void upon February 18, 2008. (changed "shall be void upon" to "expire as of")

Removed restriction: OAC 3745-21-07(A)(4): The associated requirements covered by this comment shall include: (removed shall)

Removed restriction: OAC 3745-21-07(A)(5): This rule shall not apply to any source (changed "shall" to "does")

Removed restriction: OAC 3745-21-07(A)(6): The use of emissions test data, if available, from a source or operation specified in paragraphs (K) to (N) of this rule shall take precedence over the use of an emission factor approved by the USEPA or the use of emission test data from similar sources or operations. (removed shall)

Removed restriction: OAC 3745-21-07(K)(2)(a): The storage tank shall be equipped with a floating pontoon or double-deck type cover that includes closure seals to enclose any space between the cover's edge and the compartment wall. This control requirement shall not be permitted if the liquid organic material in the tank has a vapor pressure of 12.5 pounds per square inch absolute or greater under actual storage conditions. (Changed to: A floating pontoon or double-deck type cover that includes closure seals to enclose any space between the cover's edge and the compartment wall provided that the liquid organic material in the tank has a vapor pressure of less than 12.5 pounds per square inch absolute under actual storage conditions)

Removed restriction: OAC 3745-21-07(K)(2)(a): All tank gauging or sampling devices shall be gas tight except when tank gauging or sampling is taking place. (change "shall be" to "remain")

Removed restriction: OAC 3745-21-07(K)(2)(b): The storage tank shall be equipped with a vapor recovery system or control system that reduces the emission of organic compounds into the atmosphere by at least ninety per cent by weight. (Changed to: A vapor recovery system or control system that reduces the emission of organic compounds into the atmosphere by at least ninety per cent by weight.)

Removed restriction: OAC 3745-21-07(K)(2)(b): All tank gauging or sampling devices shall be gas tight except when tank gauging or sampling is taking place. (change "shall be" to "remain")

Removed restriction: OAC 3745-21-07(L)(2)(a): The oil-water separator shall be equipped with a solid cover with all openings sealed and totally enclosing the liquid contents of the compartment. (Changed to: A solid cover with all openings sealed and totally enclosing the liquid contents of the compartment)

Removed restriction: OAC 3745-21-07(L)(2)(a): All gauging and sampling devices shall be gas tight except when gauging or sampling is taking place. (changed "shall be" to "remaining")

Removed restriction: OAC 3745-21-07(L)(2)(b): The oil-water separator shall be equipped with a floating pontoon or double-deck type cover that includes closure seals to enclose any space between the cover's edge and compartment wall. (Changed to: A floating pontoon or double-deck type cover that includes closure seals to enclose any space between the cover's edge and compartment wall.)

Removed restriction: OAC 3745-21-07(L)(2)(b): All gauging and sampling devices shall be gas tight except when gauging or sampling is taking place. (changed "shall be" to "remaining")

Removed restriction: OAC 3745-21-07(L)(2)(c): The oil-water separator shall be equipped with a vapor recovery system that reduces the emission of organic compounds into the atmosphere by at least ninety per cent by weight. (Changed to: A vapor recovery system that reduces the emission of organic compounds into the atmosphere by at least ninety per cent by weight.)

Removed restriction: OAC 3745-21-07(L)(2)(c): All gauging and sampling devices shall be gas tight except when gauging or sampling is taking place. (changed "shall be" to "remaining")

Removed restriction: OAC 3745-21-07(M)(3)(b): The owner or operator of any article, machine, equipment, or other contrivance meeting paragraph (M)(3)(a) of this rule, and not specified in paragraph (M)(1) of this rule, shall notify Ohio EPA of the need to be specified in paragraph (M)(1) of this rule. Such notification shall be submitted by May 18, 2008. (Changed to: The owner or operator of any article, machine, equipment, or other contrivance meeting paragraph (M)(3)(a) of this rule, and not specified in paragraph (M)(1) of this rule, shall notify Ohio EPA by May 18, 2008 of the need to be specified in paragraph (M)(1) of this rule.)

Removed restriction: OAC 3745-21-07(M)(3)(d): The following specific articles, machines, equipment or other contrivances shall not be subject to paragraphs (M)(3)(a) and (M)(3)(b) of this rule: (changed "shall not be subject to" to "are exempt from")

Removed restriction: OAC 3745-21-07(M)(5)(a): Paragraph (M)(2) of this rule shall not apply to... (changed "shall" to "does")

Removed restriction: OAC 3745-21-07(M)(5)(b): Paragraphs (M)(2), (M)(3)(a) and (M)(4) of this rule shall not apply to... (changed "shall" to "do")

Removed restriction: OAC 3745-21-07(M)(5)(c): Paragraph (M)(2) of this rule shall not apply to... (changed "shall" to "does")

Removed restriction: OAC 3745-21-07(M)(5)(d): Paragraphs (M)(1), (M)(2), (M)(3)(a) and (M)(4) of this rule shall not apply to... (changed "shall" to "do")

Removed restriction: OAC 3745-21-07(M)(5)(e): Paragraphs (M)(2), (M)(3)(d), (M)(3)(e), (M)(3)(f), (M)(3)(g), (M)(3)(h) and (M)(4) of this rule shall not apply to... (changed "shall" to "do")

Removed restriction: OAC 3745-21-07(M)(5)(e)(i): The equivalent best available technology requirement shall be consistent with (changed "shall be" to "is")

Removed restriction: OAC 3745-21-07(M)(5)(e)(i): ...for purposes of this paragraph, shall provide... (removed shall)

Removed restriction: OAC 3745-21-07(M)(5)(e)(i): ...the best available technology determination must comply with Section 193 of the Clean Air Act... (changed "must comply" to "complies")

Removed restriction: OAC 3745-21-07(M)(5)(e)(iii): The permit-to-install shall contain terms and conditions... (changed "shall contain" to "contains")

Removed restriction: OAC 3745-21-07(M)(5)(e)(iii): The permit-to install shall be issued by the Ohio EPA (changed "shall be" to "and that is")

Removed restriction: OAC 3745-21-07(M)(5)(f): Paragraph (M) of this rule shall not apply to... (changed "shall" to "does")

Removed restriction: OAC 3745-21-07(M)(5)(g): Paragraphs (M)(3)(a), (M)(3)(b), (M)(3)(g) and (M)(4) of this rule shall not apply to... (changed "shall" to "do")

Removed restriction: OAC 3745-21-07(M)(5)(h): Paragraph (M)(3)(g) of this rule shall not apply to... (changed "shall" to "does")

Removed restriction: OAC 3745-21-07(M)(5)(i): Paragraph (M)(2) of this rule shall not apply to... (changed "shall" to "does")

Rule Summary and Fiscal Analysis

Part C - Environmental Rule Questions

Pursuant to Am. Sub. H.B. 106 of the 121st General Assembly, prior to adopting a rule or an amendment to a rule dealing with environmental protection, or containing a component dealing with environmental protection, a state agency shall:

- (1) Consult with organizations that represent political subdivisions, environmental interests, business interests, and other persons affected by the proposed rule or amendment.
- (2) Consider documentation relevant to the need for, the environmental benefits or consequences of, other benefits of, and the technological feasibility of the proposed rule or rule amendment.
- (3) Specifically identify whether the proposed rule or rule amendment is being adopted or amended to enable the state to obtain or maintain approval to administer and enforce a federal environmental law or to participate in a federal environmental program, whether the proposed rule or rule amendment is more stringent than its federal counterpart, and, if the proposed rule or rule amendment is more stringent, the rationale for not incorporating its federal counterpart.
- (4) Include with the proposed rule or rule amendment and rule summary and fiscal analysis required to be filed with the Joint Committee on Agency Rule Review information relevant to the previously listed requirements.

(A) Were organizations that represent political subdivisions, environmental interests, business interests, and other persons affected by the proposed rule or amendment consulted? Yes

Please list each contact.

A draft of these rules was released for a 30-day public comment and review period ending June 18, 2021. The rules were released to Ohio EPA's electronic interested parties list, posted on Ohio EPA's regulations website and shared with interested industry parties. Several comments were received on Ohio EPA's rulemaking effort. Ohio EPA's response to comments document can be provided upon request. A copy of Ohio EPA's interested parties distribution list can be made available upon request.

(B) Was documentation that is relevant to the need for, the environmental benefits or consequences of, other benefits of, and the technological feasibility of the proposed rule or amendment considered? Yes

Please list the information provided and attach a copy of each piece of documentation to this form. (A SUMMARY OR INDEX MAY BE ATTACHED IN LIEU OF THE ACTUAL DOCUMENTATION.)

Clean Air Act, USEPA Control Technique Guidance Documents, LSC Style and Formatting Manual, and comments from interested parties.

- (C) Is the proposed rule or rule amendment being adopted or amended to enable the state to obtain or maintain approval to administer and enforce a federal environmental law or to participate in a federal environmental program? Yes**

Is the proposed rule or rule amendment more stringent than its federal counterpart?
No Not Applicable

- (D) If this is a rule amendment that is being adopted under a state statute that establishes standards with which the amendment is to comply, is the proposed rule amendment more stringent than the rule that it is proposing to amend? No**

Rule Summary and Fiscal Analysis

Part A - General Questions

Rule Number: 3745-21-09

Rule Type: Amendment

Rule Title/Tagline: Control of emissions of volatile organic compounds from stationary sources and perchloroethylene from dry cleaning facilities.

Agency Name: Ohio Environmental Protection Agency

Division:

Address: 50 West Town Street, Suite 700 PO Box 1049 Columbus OH 43216-1049

Contact: Holly Kaloz **Phone:** 614-644-2760

Email: holly.kaloz@epa.ohio.gov

I. Rule Summary

1. **Is this a five year rule review?** Yes
 - A. **What is the rule's five year review date?** 11/29/2021
2. **Is this rule the result of recent legislation?** No
3. **What statute is this rule being promulgated under?** 119.03
4. **What statute(s) grant rule writing authority?** 3704.03(E)
5. **What statute(s) does the rule implement or amplify?** 3704.03(A), 3704.03(E)
6. **What are the reasons for proposing the rule?**

This rule is being filed to fulfill the requirements of ORC 106.03 (5-yr review) and to adopt mandatory Reasonably Available Control Technology (RACT) requirements for the Cincinnati and Cleveland 2015 ozone nonattainment areas.

7. **Summarize the rule's content, and if this is an amended rule, also summarize the rule's changes.**

This rule identifies VOC emission and control requirements for several source categories that emit VOC. Amendments pursuant to the 5-year review are being

made to correct formatting to meet LSC requirements, to update facility names and addresses, to remove permanently closed facilities, and to remove unnecessary restriction language from the rule. In addition, amendments are being made to expand RACT requirements to the Cincinnati nonattainment area.

8. **Does the rule incorporate material by reference? Yes**
9. **If the rule incorporates material by reference and the agency claims the material is exempt pursuant to R.C. 121.75, please explain the basis for the exemption and how an individual can find the referenced material.**

This rule contains references to the Ohio Administrative Code (OAC). While copies of these rules and statutes are generally available to the public through libraries and on-line sources, including the Ohio EPA website, ORC 121.76 (A) exempts such references from the provisions of ORC 121.71 through 121.75.

This rule also contains references to the Code of Federal Regulations (CFR). These rules are generally available through libraries, Ohio EPA and U.S. EPA websites. CFR references have also been dated to reference the specific version of the rules. ORC 121.75 (D) exempts such references from the requirements of ORC 121.71 through 121.74.

This rule also contains references to the United States Code (USC), the Federal Insecticide, Rodenticide, and Fungicide Act, and the Clean Air Act. These rules and Acts are generally available through libraries, Ohio EPA and Government Printing Office's websites. USC references have also been dated to reference the specific version of the rules. ORC 121.75(D) exempts such references from the requirements of ORC 121.71 through 121.74.

The rule also contains references to analytical test methods used to determine parameters for materials subject to this rule or other materials utilized by regulators and impacted parties to determine or achieve compliance with these rules. These test methods and materials are commonly known and utilized by laboratories performing this type of analytical work. Copies of these test methods are available in libraries and the websites of the method's supporting organization (ASTM, ANSI, NFPA, NACE, etc.).

Referenced materials are cited, dated and availability noted in paragraph (JJ) of rule 3745-21-01 of the Administrative Code.

10. **If revising or re-filing the rule, please indicate the changes made in the revised or re-filed version of the rule.**

Ohio EPA's website is converting to the State of Ohio IOP platform during the comment period for this rule-making, therefore the link to the rules in the public notice would no longer work. Ohio EPA is revise filing to change the public notice to the updated web location.

II. Fiscal Analysis

11. Please estimate the increase / decrease in the agency's revenues or expenditures in the current biennium due to this rule.

This will have no impact on revenues or expenditures.

0.00

Not Applicable

12. What are the estimated costs of compliance for all persons and/or organizations directly affected by the rule?

OAC Chapter 3745-21 has been in the OAC since 1972. The rules have evolved over the years to address requirements in the Clean Air Act to develop regulations as part of an effort to achieve the NAAQS for CO and ozone within the state. These rules and additional technical support were submitted to U.S. EPA for review and approval as part of the SIP.

This Chapter has been modified over the years to incorporate requirements for categories of sources for which U.S. EPA has indicated that RACT should apply. In general, the levels of control that are available have been evaluated and presented in a series of CTGs issued by U.S. EPA. There are also rules based on information provided by U.S. EPA for other sources which were identified as non-CTG RACT.

Given the many and varied types of processes that are regulated under OAC chapter 3745-21, it is difficult to give an exact cost of compliance with the rules in this chapter in a limited space. The cost of compliance with these rules can range from zero cost for a control technology such as a work practice or raw material change, to a few million dollars for the installation and operation of a mechanical control device. As part of the permitting process, facilities can perform a RACT analysis which allows them to determine, based on all technologies available, the best and most cost-effective control strategy for their facility.

This rule has been in effect for several years. Most of the costs associated with compliance with the existing requirements of this rule have been addressed in

previous rulemakings and have been well established in the industry. There may be some additional cost of compliance related to the expansion of the requirements in the Cincinnati ozone nonattainment area in order to meet mandatory RACT requirements; however, many of the facilities affected by this expansion may already meet the requirements and not incur additional costs.

It should be noted that CTG based rules similar to Ohio's rules can also be found in Ohio's neighbor states and in any state containing a moderate ozone non-attainment area. Facilities wishing to locate in these types of areas will need to meet these requirements in all states.

13. **Does the rule increase local government costs? (If yes, you must complete an RSFA Part B). Yes**
14. **Does the rule regulate environmental protection? (If yes, you must complete an RSFA Part C). Yes**
15. **If the rule imposes a regulation fee, explain how the fee directly relates to your agency's cost in regulating the individual or business.**

Not Applicable

III. Common Sense Initiative (CSI) Questions

16. **Was this rule filed with the Common Sense Initiative Office? Yes**
17. **Does this rule have an adverse impact on business? Yes**
 - A. **Does this rule require a license, permit, or any other prior authorization to engage in or operate a line of business? No**
 - B. **Does this rule impose a criminal penalty, a civil penalty, or another sanction, or create a cause of action, for failure to comply with its terms? No**
 - C. **Does this rule require specific expenditures or the report of information as a condition of compliance? Yes**

The rule requires periodic submission of reports that typically include deviations from requirements and exceedances of emissions limits. These costs are discussed in the fiscal analysis for this rule.

- D. Is it likely that the rule will directly reduce the revenue or increase the expenses of the lines of business of which it will apply or applies? No

IV. Regulatory Restrictions (This section only applies to agencies indicated in R.C. 121.95 (A))

18. Are you adding a new or removing an existing regulatory restriction as defined in R.C. 121.95? Yes

- A. How many new regulatory restrictions do you propose adding? 1

New restriction: OAC 3745-21-09(EEE): Portable oil and gas sources. Portable oil and gas sources relocating to Butler, Clermont, Cuyahoga, Geauga, Hamilton, Lake, Lorain, Medina, Portage, or Summit or Warren county may be subject to the USEPA CTG "Control Techniques Guidelines for the Oil and Natural Gas Industry". Sources subject to the requirements of this CTG shall submit an application for a federally enforceable installation permit in accordance with Chapter 3745-31 of the Administrative Code to incorporate applicable requirements of the CTG into a federally enforceable permit prior to relocation.

Removed restriction 1: OAC 3745-21-01(W): Except as otherwise provided in this paragraph, the definitions in rule 3745-15-01 of the Administrative Code and paragraph (B) of this rule shall apply to rule 3745-21-14 (removed shall)

Removed restriction 2: OAC 3745-21-01(W)(4): Irrespective of the product being produced, a batch process train which is independent of other processes shall be considered a single batch process train for purposes of this rule. (changed "shall be" to "is")

- B. How many existing regulatory restrictions do you propose removing? 107

Removed restriction: OAC 3745-21-09(B)(3)(c): A copy of such record shall be sent to the director within forty-five days after the exceedance occurs. (deleted sentence; added deadline to previous sentence)

Removed restriction: OAC 3745-21-09(B)(3)(e): A copy of such record shall be sent to the director within forty-five days after the exceedance occurs. (deleted sentence; added deadline to previous sentence)

Removed restriction: OAC 3745-21-09(B)(3)(g): A copy of such record shall be sent to the director within thirty days after the exceedance occurs. (deleted sentence; added deadline to previous sentence)

Removed restriction: OAC 3745-21-09(B)(3)(i): A copy of such record shall be sent to the director within forty-five days after the exceedance occurs. (deleted sentence; added deadline to previous sentence)

Removed restriction: OAC 3745-21-09(B)(3)(k): A copy of such record shall be sent to the director within forty-five days after the exceedance occurs. (deleted sentence; added deadline to previous sentence)

Removed restriction: OAC 3745-21-09(B)(3)(m): These quarterly reports shall be submitted by April thirtieth, July thirty-first, October thirty-first, and January thirty-first, and shall cover the records for the previous calendar quarters. (deleted sentence; added deadlines to previous sentence)

Removed restriction: OAC 3745-21-09(B)(4)(c): These quarterly reports shall be submitted by April thirtieth, July thirty-first, October thirty-first, and January thirty-first, and shall cover the records for the previous calendar quarters. (deleted sentence; added deadlines to previous sentence)

Removed restriction: OAC 3745-21-09(B)(4)(d): The continuous monitoring and recording devices shall be installed and placed in operation either within one hundred eighty days of March 31, 1993 or by the date of operation of any new control equipment installed for the source after March 31, 1993 to achieve compliance with the VOC control requirements of this rule. (deleted sentence; added deadlines to previous sentence)

Removed restriction: OAC 3745-21-09(B)(5): the alternative recordkeeping and reporting program shall supersede paragraph (B)(3) or (B)(4) of this rule and shall be specified in the terms and conditions of the permit (removed shall)

Removed restriction: OAC 3745-21-09(B)(5): Any alternative recordkeeping and reporting program approved by the director shall also be approved by the USEPA as a revision to the state implementation plan. (deleted sentence; added "and USEPA as a revision to the state implementation plan" to previous sentence)

Removed restriction: OAC 3745-21-09(C): For any source located in Ashtabula, Cuyahoga, Geauga, Lake, Lorain, Medina, Portage, or Summit county subject to paragraph (C) of this rule, the requirement to comply with paragraph (C) of this

rule shall terminate at such time the source becomes subject to and complies with rule 3745-21-29 of the Administrative Code. (changed "shall terminate" to "terminates")

Removed restriction: OAC 3745-21-09(C)(1)(a)(ii): RT shall be calculated as follows: (changed "shall be" to "is")

Removed restriction: OAC 3745-21-09(C)(5)(b): A copy of such monthly record shall be sent to the director within thirty days following the end of the calendar month. (deleted sentence; added deadline to previous sentence)

Removed restriction: OAC 3745-21-09(C)(7)(b): A copy of such monthly record shall be sent to the director within thirty days following the end of the calendar month. (deleted sentence; added deadline to previous sentence)

Removed restriction: OAC 3745-21-09(C)(8)(d): The calculated, controlled VOC emission rate, in mass of VOC per unit volume of coating solids, as applied. The controlled VOC emission rate shall be: (changed to "The calculated, controlled VOC emission rate, in mass of VOC per unit volume of coating solids, as applied, calculated using the following:")

Removed restriction: OAC 3745-21-09(C)(9): A copy of such monthly record shall be sent to the director within thirty days following the end of the calendar month. (deleted sentence; added deadline to previous sentence)

Removed restriction: OAC 3745-21-09(H)(3): Paragraphs (H)(1) and (H)(2) of this rule shall not apply to the application of organisol or plastisol coatings. (changed to "The application of organisol or plastisol coatings are exempt from paragraphs (H)(1) and (H)(2) of this rule.")

Removed restriction: OAC 3745-21-09(I)(4)(b)(iii): Paragraphs (I)(4)(a) and (I)(4)(d) of this rule shall not apply to the following: (changed "shall not apply" to "are not applicable")

Removed restriction: OAC 3745-21-09(K)(2): The emission limit under paragraph (K)(1) of this rule shall not apply to C_6H_6 ; (changed "shall" to "does")

Removed restriction: OAC 3745-21-09(K)(4): The emission limit under paragraph (K)(1) of this rule shall not apply to C_6H_6 ; (changed "shall" to "does")

Removed restriction: OAC 3745-21-09(K)(5): The emission limit under paragraph (K)(1) of this rule shall not apply to (changed "shall" to "does")

Removed restriction: OAC 3745-21-09(K)(6)(b)(ii): Paragraphs (K)(6)(a) and (K)(6)(e) of this rule shall not apply to the following: (changed "shall" to "do")

Removed restriction: OAC 3745-21-09(L)(3): Any owner or operator of a fixed roof tank that is not exempted pursuant to paragraph (L)(2) of this rule shall maintain records of the following information in a readily accessible location for at least five years and shall make copies of the records (removed shall)

Removed restriction: OAC 3745-21-09(M)(3)(b): Such records shall include including the following: (changed to "including")

Removed restriction: OAC 3745-21-09(N)(3): Paragraphs (N)(1) and (N)(2) of this rule shall not apply to the following: (changed "shall" to "do")

Removed restriction: OAC 3745-21-09(O)(5): Any owner or operator of a solvent metal cleaning operation shall maintain records of the following information in a readily accessible location for at least five years and shall make these records available (removed shall)

Removed restriction: OAC 3745-21-09(O)(6)(a): Paragraph (O)(2)(d)(v) of this rule shall not apply to (changed "shall" to "does")

Removed restriction: OAC 3745-21-09(O)(6)(b): paragraphs (O)(2) to (O)(5) of this rule shall not apply to (changed "shall" to "do")

Removed restriction: OAC 3745-21-09(O)(6)(d): Such documentation shall be provided to the appropriate Ohio EPA district office or local air agency. (changed "such documentation shall" to "and documentation is")

Removed restriction: OAC 3745-21-09(P)(2): the following operating practices shall be followed (changed "shall be followed" to "are applicable")

Removed restriction: OAC 3745-21-09(P)(2)(a): The vapor balance system shall be kept in good working order and shall be used at all times during the transfer of gasoline. (removed shall be)

Removed restriction: OAC 3745-21-09(P)(5)(a): Paragraphs (P)(1) to (P)(4) of this rule shall not apply (changed "shall not apply" to "are not applicable")

Removed restriction: OAC 3745-21-09(P)(5)(b): Paragraph (P)(1)(b) of this rule shall not apply (changed "shall not apply" to "is not applicable")

Removed restriction: OAC 3745-21-09(P)(6): Any owner or operator of a bulk gasoline plant shall maintain records of the following information in a readily accessible location for at least five years and shall immediately make these records available (removed shall)

Removed restriction: OAC 3745-21-09(Q)(4): Paragraph (Q)(1) of this rule shall not apply to (changed "shall" to "does")

Removed restriction: OAC 3745-21-09(R)(2): the following operating practices shall be followed (changed "shall be followed" to "are applicable")

Removed restriction: OAC 3745-21-09(R)(2)(a): The vapor balance system shall be kept in good working order and shall be used at all times during the transfer of gasoline. (changed to "A vapor balance system kept in good working order and used at all times during the transfer of gasoline.")

Removed restriction: OAC 3745-21-09(R)(2)(b): There shall be no leaks in the delivery vessel pressure/vacuum relief valves and hatch covers. (changed to "Secure delivery vessel pressure/vacuum relief valves and hatch covers which do not leak.")

Removed restriction: OAC 3745-21-09(R)(2)(c): There shall be no leaks in the vapor and liquid lines during the transfer of gasoline. (changed to "Secure vapor and liquid lines which do not leak during the transfer of gasoline.")

Removed restriction: OAC 3745-21-09(R)(4): Paragraphs (R)(1) to (R)(3) of this rule shall not apply to the following: (changed "shall" to "do")

Removed restriction: OAC 3745-21-09(R)(5): The records shall be maintained at the facility for a period of three years. (removed shall and moved to list form following)

Removed restriction: OAC 3745-21-09(R)(5): The owner or operator shall notify the director if the annual gasoline throughput for any rolling twelve-month period is equal to or greater than one hundred twenty thousand gallons. (removed shall and moved to list form following)

Removed restriction: OAC 3745-21-09(R)(5): The director shall be notified within forty-five days after the exceedance occurs. (removed shall and moved to list form following)

Removed restriction: OAC 3745-21-09(T)(1)(e): The tag shall be readily visible and weatherproof (removed shall and moved to list form following)

Removed restriction: OAC 3745-21-09(T)(1)(e): it shall bear an identification number (removed shall and moved to list form following)

Removed restriction: OAC 3745-21-09(T)(1)(e): and it shall clearly indicate the date the leak was detected (removed shall and moved to list form following)

Removed restriction: OAC 3745-21-09(T)(1)(e): The tag shall remain in place until the leaking component is repaired. (removed shall and moved to list form following)

Removed restriction: OAC 3745-21-09(T)(1)(f): The monitoring log shall contain (changed to "containing")

Removed restriction: OAC 3745-21-09(T)(4): \hat{a} shall be acceptable to the director. (changed "shall be" to "is")

Removed restriction: OAC 3745-21-09(U)(1): the limit which is least restrictive shall apply (changed "shall apply" to "applies")

Removed restriction: OAC 3745-21-09(U)(2): Paragraph (U)(1) of this rule shall not apply (changed "shall not apply" to "is not applicable")

Removed restriction: OAC 3745-21-09(U)(2)(e)(iii): paragraphs (U)(2)(e)(i) to (U)(2)(e)(iii) of this rule shall not apply (changed "shall not apply" to "is not applicable")

Removed restriction: OAC 3745-21-09(U)(2)(f)(ii): \hat{a} The alternative limitation shall be \hat{a} (changed to " provided the alternative limit is")

Removed restriction: OAC 3745-21-09(U)(2)(f)(ii): The alternative limitation shall be an emissions rate (e.g., pounds VOC per gallon) or overall per cent reduction but shall not be in terms of mass per time (e.g., pounds per hour). (changed to "and is expressed as an emissions rate (e.g., pounds VOC per gallon) or overall per cent reduction but not in terms of mass per time (e.g., pounds per hour).")

Removed restriction: OAC 3745-21-09(U)(2)(f)(iii): The installation permit shall containâ | (changed to "containing")

Removed restriction: OAC 3745-21-09(U)(2)(h): (pounds of VOC attributed to metal parts or products coating lines in which non-metal parts or products were being coated shall not count towards (changed "shall not count" to "is exempt from counting")

Removed restriction: OAC 3745-21-09(V)(1)(h): the gasoline tank truck shall also be inspected/repared in accordance with the following procedures (changed to "the following inspection and repair procedures apply")

Removed restriction: OAC 3745-21-09(X)(2): Paragraph (X)(1) of this rule shall not apply to the following operations: (changed to "The following operations are exempt from the requirements of paragraph Paragraph (X)(1) of this rule")

Removed restriction: OAC 3745-21-09(Y)(2): Paragraph (Y)(1) of this rule shall not apply (changed "shall not apply" to "is not applicable")

Removed restriction: OAC 3745-21-09(Z)(3): The following external floating roof tanks shall be exempted (changed "shall be" to "are")

Removed restriction: OAC 3745-21-09(Z)(4): and shall make copies of the records available (removed shall)

Removed restriction: OAC 3745-21-09(AA)(2)(a): Paragraphs (AA)(1)(a) to (AA)(1)(e) of this rule shall not apply (changed "shall not apply" to "are not applicable")

Removed restriction: OAC 3745-21-09(AA)(2)(b): Paragraph (AA)(1)(a) of this rule shall not apply (changed "shall not apply" to "is not applicable")

Removed restriction: OAC 3745-21-09(AA)(2)(c): Paragraph (AA)(1)(a) of this rule shall not apply (changed "shall not apply" to "is not applicable")

Removed restriction: OAC 3745-21-09(AA)(4): and shall make these records available (removed shall)

Removed restriction: OAC 3745-21-09(BB)(1)(e): The leak shall be repaired (changed "The leak shall be" to "and the leak")

Removed restriction: OAC 3745-21-09(BB)(3): Paragraphs (BB)(1)(a), (BB)(1)(b), and (BB)(2) of this rule shall not apply (changed "shall" to "do")

Removed restriction: OAC 3745-21-09(BB)(4)(a): and shall make these records available (removed shall)

Removed restriction: OAC 3745-21-09(BB)(4)(b): and shall make these records available (removed shall)

Removed restriction: OAC 3745-21-09(DD)(2)(b)(i): Any pump in light liquid service shall be monitored monthly. (changed to "Monthly for any pump in light liquid service.")

Removed restriction: OAC 3745-21-09(DD)(2)(b)(ii): Any valve in gas/vapor service or in light liquid service shall be monitored monthly (changed to "Monthly for any valve in gas/vapor service or in light liquid service")

Removed restriction: OAC 3745-21-09(DD)(2)(b)(ii): The quarterly monitoring shall begin (changed to "beginning")

Removed restriction: OAC 3745-21-09(DD)(2)(b)(ii): and shall be conducted in the first month of each calendar quarter (removed "shall be")

Removed restriction: OAC 3745-21-09(DD)(2)(j): and the first attempts at repair shall include (changed to "including")

Removed restriction: OAC 3745-21-09(DD)(2)(m): and shall include the following information (removed shall)

Removed restriction: OAC 3745-21-09(DD)(8)(c): The barrier fluid system shall be in heavy liquid service or shall not be in VOC service. (removed shall)

Removed restriction: OAC 3745-21-09(DD)(10)(d)(i): The flare shall be designed (changed to "Designed")

Removed restriction: OAC 3745-21-09(DD)(10)(d)(ii): The flare shall be operated (changed to "Operated")

Removed restriction: OAC 3745-21-09(DD)(10)(d)(ii): and shall be monitored with a thermocouple (removed shall)

Removed restriction: OAC 3745-21-09(DD)(10)(d)(ii): and shall be monitored to detect any failure (removed shall)

Removed restriction: OAC 3745-21-09(DD)(10)(d)(iii): The flare shall be (changed to "Be")

Removed restriction: OAC 3745-21-09(DD)(10)(d)(iv): or shall be two hundred Btu/scf or greater (removed "shall be")

Removed restriction: OAC 3745-21-09(DD)(10)(d)(v): the flare shall be designed and operated (removed "the flare shall")

Removed restriction: OAC 3745-21-09(DD)(10)(d)(vi)(a): shall be greater than one thousand Btu/scf (changed "shall be" to "is")

Removed restriction: OAC 3745-21-09(DD)(10)(d)(vi)(b): The flare shall be designed and operated (changed "shall be" to "is")

Removed restriction: OAC 3745-21-09(DD)(11)(b): A delay of repair shall be allowed if the repair is technically infeasible without a process unit shutdown. However, the repair shall occur before the end of the next process unit shutdown. (changed to "If the repair is technically infeasible without a process unit shutdown providing the repair occurs before the end of the next process unit shutdown.")

Removed restriction: OAC 3745-21-09(DD)(11)(c): A delay of repair shall be allowed for a piece of equipment that is (changed to "For a piece of equipment that is")

Removed restriction: OAC 3745-21-09(DD)(11)(d): A delay of repair for a valve shall be allowed if the following occurs: (changed to "For a valve shall be allowed if the following occurs:")

Removed restriction: OAC 3745-21-09(DD)(11)(e): A delay of repair for For a pump shall be allowed if the following occurs: (changed to "For a pump shall be allowed if the following occurs:")

Removed restriction: OAC 3745-21-09(DD)(11)(f): A delay of repair beyond a process unit shutdown shall be allowed for a valve if (changed to "Beyond a process unit shutdown for a valve provided")

Removed restriction: OAC 3745-21-09(DD)(13)(a): The alternative monitoring standard shall be based on maintaining the percentage of valves leaking at 2.0 or less. (removed sentence and added percentage to previous sentence)

Removed restriction: OAC 3745-21-09(DD)(13)(f)(i): All valves subject to this alternative monitoring standard shall be monitored (changed to "Monitor valves subject to this alternative monitoring standard")

Removed restriction: OAC 3745-21-09(DD)(13)(f)(iii): The percentage of valves leaking shall be determined (changed to "Determine the percentage of valves leaking")

Removed restriction: OAC 3745-21-09(DD)(15)(b): The results of such compliance tests shall be reported (changed to "and the results of such compliance tests reported")

Removed restriction: OAC 3745-21-09(DD)(15)(c): The semiannual reports shall be submitted by (changed to "and submitted by")

Removed restriction: OAC 3745-21-09(DD)(15)(c): and shall include information for (removed shall)

Removed restriction: OAC 3745-21-09(EE)(2)(a): shall be exempt from (changed "shall be" to "is")

Removed restriction: OAC 3745-21-09(EE)(2)(a): This exemption shall terminate (changed "shall terminate" to "terminates")

Removed restriction: OAC 3745-21-09(EE)(2)(b): shall be exempt from (changed "shall be" to "is")

Removed restriction: OAC 3745-21-09(EE)(2)(b): shall be based upon (changed "shall be" to "is")

Removed restriction: OAC 3745-21-09(FF): shall comply with the following (changed to "is subject to the following")

Removed restriction: OAC 3745-21-09(FF)(2): These records shall be maintained at the facility for a period of three years. (removed; added timeline to previous sentence)

Removed restriction: OAC 3745-21-09(FF)(2): A copy of the record showing the exceedance shall be submitted to the director within thirty days after the exceedance occurs. (removed; added deadline to previous sentence)

Removed restriction: OAC 3745-21-09(JJ): shall comply (changed to "is subject to")

Removed restriction: OAC 3745-21-09(KK): shall comply (changed to "is subject to")

Removed restriction: OAC 3745-21-09(LL): shall comply (changed to "is subject to")

Removed restriction: OAC 3745-21-09(MM)(1): The paint manufacturing operations shall include the following equipment for the processing or use of solvent based or waterbased paint materials: mixing tanks for paint liquids and pigments, grinding mills, paint thinning and tinting tanks, paint filling equipment for shipping containers, cleaning equipment for paint processing equipment, and recovery equipment for the cleaning solvents. The paint laboratory operations shall include the following equipment for the processing or use of solvent based or waterbased paint materials: paint spray booths and associated ovens within the paint manufacturing quality control laboratory and the paint research laboratory (removed; changed to list form)

Rule Summary and Fiscal Analysis

Part B - Local Governments Questions

1. Does the rule increase costs for:

A. Public School Districts	No
B. County Government	Yes
C. Township Government	Yes
D. City and Village Governments	Yes

2. Please estimate the total cost, in dollars, of compliance with the rule for the affected local government(s). If you cannot give a dollar cost, explain how the local government is financially impacted.

OAC Chapter 3745-21 has been in the OAC since 1972. The rules have evolved over the years to address requirements in the Clean Air Act to develop regulations as part of an effort to achieve the NAAQS for CO and ozone within the state. These rules and additional technical support were submitted to U.S. EPA for review and approval as part of the SIP.

This Chapter has been modified over the years to incorporate requirements for categories of sources for which U.S. EPA has indicated that RACT should apply. In general, the levels of control that are available have been evaluated and presented in a series of CTGs issued by U.S. EPA. There are also rules based on information provided by U.S. EPA for other sources which were identified as non-CTG RACT.

Given the many and varied types of processes that are regulated under OAC chapter 3745-21, it is difficult to give an exact cost of compliance with the rules in this chapter in a limited space. The cost of compliance with these rules can range from zero cost for a control technology such as a work practice or raw material change, to a few million dollars for the installation and operation of a mechanical control device. As part of the permitting process, facilities can perform a RACT analysis which allows them to determine, based on all technologies available, the best and most cost-effective control strategy for their facility.

This rule has been in effect for several years. Most of the costs associated with compliance with the existing requirements of this rule have been addressed in previous rulemakings and have been well established in the industry. There may be some additional cost of compliance related to the expansion of the requirements in the

Cincinnati ozone nonattainment area in order to meet mandatory RACT requirements; however, many of the facilities affected by this expansion may already meet the requirements and not incur additional costs.

It should be noted that CTG based rules similar to Ohio's rules can also be found in Ohio's neighbor states and in any state containing a moderate ozone non-attainment area. Facilities wishing to locate in these types of areas will need to meet these requirements in all states.

3. **Is this rule the result of a federal government requirement? Yes**
 - A. **If yes, does this rule do more than the federal government requires? No**
 - B. **If yes, what are the costs, in dollars, to the local government for the regulation that exceeds the federal government requirement?**

Not Applicable
4. **Please provide an estimated cost of compliance for the proposed rule if it has an impact on the following:**
 - A. **Personnel Costs**

See above.
 - B. **New Equipment or Other Capital Costs**

See above.
 - C. **Operating Costs**

See above.
 - D. **Any Indirect Central Service Costs**

See above.
 - E. **Other Costs**

See above.
5. **Please explain how the local government(s) will be able to pay for the increased costs associated with the rule.**

Ohio EPA acknowledges that there will be an increase in costs associated with the expansion of the requirements in the Cincinnati ozone nonattainment area in order to meet mandatory RACT requirements; however, many of the facilities affected by this expansion may already meet the requirements and not incur additional costs. Facilities that are affected will need to adjust their operational and maintenance budgets accordingly. These budgets are typically financed through a general fund.

6. What will be the impact on economic development, if any, as the result of this rule?

These rules are being promulgated to implement federal requirements for the application of reasonably available control technology to source categories of VOC in moderate ozone non-attainment areas. Rules governing VOC for these source types are in effect in many places around the country, and are not unique to the area covered by this rule. Therefore, any potential economic impact in the affected area would be minimal.

Reducing emissions benefits the affected area by providing a cost savings and economic benefit to stakeholders through reduced pollution. Not only does reducing pollution provide for better enjoyment of the states resources through cleaner air but also reduces property damage caused by pollution, reduces illnesses and reduces healthcare costs. The cost benefits, although difficult to quantify, are significant and may exceed the cost incurred by regulated entities required to comply with VOC RACT rules.

Rule Summary and Fiscal Analysis

Part C - Environmental Rule Questions

Pursuant to Am. Sub. H.B. 106 of the 121st General Assembly, prior to adopting a rule or an amendment to a rule dealing with environmental protection, or containing a component dealing with environmental protection, a state agency shall:

- (1) Consult with organizations that represent political subdivisions, environmental interests, business interests, and other persons affected by the proposed rule or amendment.
- (2) Consider documentation relevant to the need for, the environmental benefits or consequences of, other benefits of, and the technological feasibility of the proposed rule or rule amendment.
- (3) Specifically identify whether the proposed rule or rule amendment is being adopted or amended to enable the state to obtain or maintain approval to administer and enforce a federal environmental law or to participate in a federal environmental program, whether the proposed rule or rule amendment is more stringent than its federal counterpart, and, if the proposed rule or rule amendment is more stringent, the rationale for not incorporating its federal counterpart.
- (4) Include with the proposed rule or rule amendment and rule summary and fiscal analysis required to be filed with the Joint Committee on Agency Rule Review information relevant to the previously listed requirements.

(A) Were organizations that represent political subdivisions, environmental interests, business interests, and other persons affected by the proposed rule or amendment consulted? Yes

Please list each contact.

A draft of these rules was released for a 30-day public comment and review period ending June 18, 2021. The rules were released to Ohio EPA's electronic interested parties list, posted on Ohio EPA's regulations website and shared with interested industry parties. Several comments were received on Ohio EPA's rulemaking effort. Ohio EPA's response to comments document can be provided upon request. A copy of Ohio EPA's interested parties distribution list can be made available upon request.

(B) Was documentation that is relevant to the need for, the environmental benefits or consequences of, other benefits of, and the technological feasibility of the proposed rule or amendment considered? Yes

Please list the information provided and attach a copy of each piece of documentation to this form. (A SUMMARY OR INDEX MAY BE ATTACHED IN LIEU OF THE ACTUAL DOCUMENTATION.)

Clean Air Act, USEPA Control Technique Guidance Documents, LSC Style and Formatting Manual, and comments from interested parties.

- (C) Is the proposed rule or rule amendment being adopted or amended to enable the state to obtain or maintain approval to administer and enforce a federal environmental law or to participate in a federal environmental program? Yes**

Is the proposed rule or rule amendment more stringent than its federal counterpart?
No Not Applicable

- (D) If this is a rule amendment that is being adopted under a state statute that establishes standards with which the amendment is to comply, is the proposed rule amendment more stringent than the rule that it is proposing to amend? No**

Rule Summary and Fiscal Analysis

Part A - General Questions

Rule Number: 3745-21-10

Rule Type: Amendment

Rule Title/Tagline: Compliance test methods and procedures.

Agency Name: Ohio Environmental Protection Agency

Division:

Address: 50 West Town Street, Suite 700 PO Box 1049 Columbus OH 43216-1049

Contact: Holly Kaloz **Phone:** 614-644-2760

Email: holly.kaloz@epa.ohio.gov

I. Rule Summary

1. **Is this a five year rule review?** Yes
 - A. **What is the rule's five year review date?** 11/29/2021
2. **Is this rule the result of recent legislation?** No
3. **What statute is this rule being promulgated under?** 119.03
4. **What statute(s) grant rule writing authority?** 3704.03(E)
5. **What statute(s) does the rule implement or amplify?** 3704.03(A), 3704.03(E)
6. **What are the reasons for proposing the rule?**

This rule is being filed to fulfill the requirements of ORC 106.03 (5-yr review).

7. **Summarize the rule's content, and if this is an amended rule, also summarize the rule's changes.**

This rule identifies compliance test methods for sources of VOC. This rule is being amended to update test method, publication and referenced material titles, effective dates, addresses and web sites.

8. **Does the rule incorporate material by reference?** Yes

9. **If the rule incorporates material by reference and the agency claims the material is exempt pursuant to R.C. 121.75, please explain the basis for the exemption and how an individual can find the referenced material.**

This rule contains references to the Ohio Administrative Code (OAC). While copies of these rules and statutes are generally available to the public through libraries and on-line sources, including the Ohio EPA website, ORC 121.76 (A) exempts such references from the provisions of ORC 121.71 through 121.75.

This rule also contains references to the Code of Federal Regulations (CFR). These rules are generally available through libraries, Ohio EPA and U.S. EPA websites. CFR references have also been dated to reference the specific version of the rules. ORC 121.75 (D) exempts such references from the requirements of ORC 121.71 through 121.74.

The rule also contains references to analytical test methods used to determine parameters for materials subject to this rule or other materials utilized by regulators and impacted parties to determine or achieve compliance with these rules. These test methods and materials are commonly known and utilized by laboratories performing this type of analytical work. Copies of these test methods are available in libraries and the websites of the method's supporting organization (ASTM, ANSI, NFPA, NACE, etc.).

Referenced materials are cited, dated and availability noted in paragraph (JJ) of rule 3745-21-01 of the Administrative Code.

10. **If revising or re-filing the rule, please indicate the changes made in the revised or re-filed version of the rule.**

Ohio EPA's website is converting to the State of Ohio IOP platform during the comment period for this rule-making, therefore the link to the rules in the public notice would no longer work. Ohio EPA is revise filing to change the public notice to the updated web location.

II. Fiscal Analysis

11. **Please estimate the increase / decrease in the agency's revenues or expenditures in the current biennium due to this rule.**

This will have no impact on revenues or expenditures.

0.00

Not Applicable

12. What are the estimated costs of compliance for all persons and/or organizations directly affected by the rule?

This rule identifies test methods to be used to demonstrate compliance for sources of VOC. This rule does not specifically require the testing, the rule provides information on the methods to use when testing is required elsewhere in this chapter.

For facilities performing a compliance test per this rule, an intent to test notification and final test report are required to be submitted. The cost of providing this notification is estimated to be a few hundred to a thousand dollars depending on the number of tests being performed and number of emission units being tested. This cost consists of labor charges to collect and prepare the required information for the notification.

This rule has been in effect for 40+ years. All costs associated with compliance with the existing requirements of this rule have been well established in industry. The amendments being made to this rule do not add any additional requirements to affected facilities. As such, there is no additional cost of compliance associated with the amendments being made to this rule.

13. Does the rule increase local government costs? (If yes, you must complete an RSFA Part B). No

14. Does the rule regulate environmental protection? (If yes, you must complete an RSFA Part C). Yes

15. If the rule imposes a regulation fee, explain how the fee directly relates to your agency's cost in regulating the individual or business.

Not Applicable

III. Common Sense Initiative (CSI) Questions

16. Was this rule filed with the Common Sense Initiative Office? Yes

17. Does this rule have an adverse impact on business? Yes

A. Does this rule require a license, permit, or any other prior authorization to engage in or operate a line of business? No

- B. Does this rule impose a criminal penalty, a civil penalty, or another sanction, or create a cause of action, for failure to comply with its terms? No**
- C. Does this rule require specific expenditures or the report of information as a condition of compliance? Yes**

For facilities performing a compliance test per this rule, an intent to test notification and final test report are required to be submitted. As for the cost of reporting, this rule has been in effect for several years. All costs associated with compliance with the existing requirements of this rule have been addressed in previous rulemakings and have been well established in the industry. The amendments being made to this rule do not add any additional requirements to affected facilities. As such, there is no additional cost of compliance associated with the amendments being made to this rule.

- D. Is it likely that the rule will directly reduce the revenue or increase the expenses of the lines of business of which it will apply or applies? No**

IV. Regulatory Restrictions (This section only applies to agencies indicated in R.C. 121.95 (A))

- 18. Are you adding a new or removing an existing regulatory restriction as defined in R.C. 121.95? No**
- A. How many new regulatory restrictions do you propose adding?**
- Not Applicable
- B. How many existing regulatory restrictions do you propose removing?**
- Not Applicable

Rule Summary and Fiscal Analysis

Part C - Environmental Rule Questions

Pursuant to Am. Sub. H.B. 106 of the 121st General Assembly, prior to adopting a rule or an amendment to a rule dealing with environmental protection, or containing a component dealing with environmental protection, a state agency shall:

- (1) Consult with organizations that represent political subdivisions, environmental interests, business interests, and other persons affected by the proposed rule or amendment.
- (2) Consider documentation relevant to the need for, the environmental benefits or consequences of, other benefits of, and the technological feasibility of the proposed rule or rule amendment.
- (3) Specifically identify whether the proposed rule or rule amendment is being adopted or amended to enable the state to obtain or maintain approval to administer and enforce a federal environmental law or to participate in a federal environmental program, whether the proposed rule or rule amendment is more stringent than its federal counterpart, and, if the proposed rule or rule amendment is more stringent, the rationale for not incorporating its federal counterpart.
- (4) Include with the proposed rule or rule amendment and rule summary and fiscal analysis required to be filed with the Joint Committee on Agency Rule Review information relevant to the previously listed requirements.

(A) Were organizations that represent political subdivisions, environmental interests, business interests, and other persons affected by the proposed rule or amendment consulted? Yes

Please list each contact.

A draft of these rules was released for a 30-day public comment and review period ending June 18, 2021. The rules were released to Ohio EPA's electronic interested parties list, posted on Ohio EPA's regulations website and shared with interested industry parties. Several comments were received on Ohio EPA's rulemaking effort. Ohio EPA's response to comments document can be provided upon request. A copy of Ohio EPA's interested parties distribution list can be made available upon request.

(B) Was documentation that is relevant to the need for, the environmental benefits or consequences of, other benefits of, and the technological feasibility of the proposed rule or amendment considered? Yes

Please list the information provided and attach a copy of each piece of documentation to this form. (A SUMMARY OR INDEX MAY BE ATTACHED IN LIEU OF THE ACTUAL DOCUMENTATION.)

Clean Air Act, USEPA Control Technique Guidance Documents, LSC Style and Formatting Manual, and comments from interested parties.

- (C) **Is the proposed rule or rule amendment being adopted or amended to enable the state to obtain or maintain approval to administer and enforce a federal environmental law or to participate in a federal environmental program? Yes**

Is the proposed rule or rule amendment more stringent than its federal counterpart?
No Not Applicable

- (D) **If this is a rule amendment that is being adopted under a state statute that establishes standards with which the amendment is to comply, is the proposed rule amendment more stringent than the rule that it is proposing to amend? No**

Rule Summary and Fiscal Analysis

Part A - General Questions

Rule Number: 3745-21-11

Rule Type: New

Rule Title/Tagline: Reasonably available control technology studies for non-CTG sources in ozone nonattainment areas.

Agency Name: Ohio Environmental Protection Agency

Division:

Address: 50 West Town Street, Suite 700 PO Box 1049 Columbus OH 43216-1049

Contact: Holly Kaloz **Phone:** 614-644-2760

Email: holly.kaloz@epa.ohio.gov

I. Rule Summary

1. **Is this a five year rule review?** No
 - A. **What is the rule's five year review date?**
2. **Is this rule the result of recent legislation?** No
3. **What statute is this rule being promulgated under?** 119.03
4. **What statute(s) grant rule writing authority?** 3704.03(E)
5. **What statute(s) does the rule implement or amplify?** 3704.03(A), 3704.03(E)
6. **What are the reasons for proposing the rule?**

This rule is being filed to adopt mandatory Reasonably Available Control Technology (RACT) requirements for the Cincinnati and Cleveland 2015 ozone nonattainment areas.

7. **Summarize the rule's content, and if this is an amended rule, also summarize the rule's changes.**

This new rule is being promulgated to require facilities in the Cincinnati and Cleveland nonattainment areas with the potential to emit 100 tons per year or more of VOC,

where not already controlled by other requirements in OAC chapter 3745-21, to submit a RACT study within one year of the effective date of the rule. This new rule also requires facilities in the nonattainment areas that have existing site-specific RACT established to submit an updated RACT study within one year of the effective date of the rule.

- 8. Does the rule incorporate material by reference? Yes**
- 9. If the rule incorporates material by reference and the agency claims the material is exempt pursuant to R.C. 121.75, please explain the basis for the exemption and how an individual can find the referenced material.**

This rule contains references to the Ohio Administrative Code (OAC). While copies of these rules and statutes are generally available to the public through libraries and on-line sources, including the Ohio EPA website, ORC 121.76 (A) exempts such references from the provisions of ORC 121.71 through 121.75.

This rule also contains references to the Code of Federal Regulations (CFR). These rules are generally available through libraries, Ohio EPA and U.S. EPA websites. CFR references have also been dated to reference the specific version of the rules. ORC 121.75 (D) exempts such references from the requirements of ORC 121.71 through 121.74.

- 10. If revising or re-filing the rule, please indicate the changes made in the revised or re-filed version of the rule.**

Ohio EPA's website is converting to the State of Ohio IOP platform during the comment period for this rule-making, therefore the link to the rules in the public notice would no longer work. Ohio EPA is revise filing to change the public notice to the updated web location.

II. Fiscal Analysis

- 11. Please estimate the increase / decrease in the agency's revenues or expenditures in the current biennium due to this rule.**

This will have no impact on revenues or expenditures.

0.00

Not Applicable

12. What are the estimated costs of compliance for all persons and/or organizations directly affected by the rule?

This rule requires facilities in the Cincinnati and Cleveland nonattainment areas meeting certain criteria to submit a new or updated RACT study and implement controls consistent with the results of that study. The cost to conduct a RACT study is estimated to be less than \$30,000. Given the many and varied types of processes that are regulated under OAC chapter 3745-21, it is difficult to give an exact cost of compliance for implementing controls. The cost of compliance can range from zero cost for a control technology such as a work practice or raw material change, to a few million dollars for the installation and operation of a mechanical control device.

13. Does the rule increase local government costs? (If yes, you must complete an RSFA Part B). Yes

14. Does the rule regulate environmental protection? (If yes, you must complete an RSFA Part C). Yes

15. If the rule imposes a regulation fee, explain how the fee directly relates to your agency's cost in regulating the individual or business.

Not Applicable

III. Common Sense Initiative (CSI) Questions

16. Was this rule filed with the Common Sense Initiative Office? Yes

17. Does this rule have an adverse impact on business? Yes

A. Does this rule require a license, permit, or any other prior authorization to engage in or operate a line of business? No

B. Does this rule impose a criminal penalty, a civil penalty, or another sanction, or create a cause of action, for failure to comply with its terms? No

C. Does this rule require specific expenditures or the report of information as a condition of compliance? Yes

The rule requires submission of a RACT study for certain sources. These costs are discussed in the fiscal analysis for this rule.

- D. Is it likely that the rule will directly reduce the revenue or increase the expenses of the lines of business of which it will apply or applies? No

IV. Regulatory Restrictions (This section only applies to agencies indicated in R.C. 121.95 (A))

18. Are you adding a new or removing an existing regulatory restriction as defined in R.C. 121.95? Yes

- A. How many new regulatory restrictions do you propose adding? 4

New restriction: OAC 3745-21-11(B): The owner or operator of any facility subject to this rule shall conduct a detailed engineering study, performed by an engineering consulting firm or other person or persons experienced in the field of air pollution control, to determine the technical and economic feasibility of reducing the VOC emissions from the sources at the facility which are not by Ohio's CTG regulations in this chapter and to define RACT for the source, providing the following information:

Removed restriction 1: OAC 3745-21-01(W)(8): "Emission event" shall be defined as a discrete period of venting that is associated with a unit operation (changed "shall be defined as" to "means")

Removed restriction 2: OAC 3745-21-01(X): Except as otherwise provided in this paragraph, the definitions in rule 3745-15-01 of the Administrative Code and paragraph (B) of this rule shall apply to rule 3745-21-15 (removed shall)

New restriction: OAC 3745-21-11(C): If upon review of this information, the director determines that the information does not or may not indicate that the definition of best available technology satisfies the requirements of this chapter, the director will so notify the owner or operator, and the owner or operator shall conduct a full RACT engineering study in accordance with paragraph (B) of this rule.

Removed restriction 1: OAC 3745-21-01(X)(1): "Adhesive" means any chemical substance that is applied for the purpose of bonding two surfaces together other than by mechanical means. Products used on humans and animals, adhesive tape, contact paper, or any other product with an adhesive incorporated onto or in an inert substrate shall not be considered adhesives. Changed to "Adhesive" means any chemical substance that is applied for the

purpose of bonding two surfaces together other than by mechanical means but does not include products used on humans and animals, adhesive tape, contact paper, or any other product with an adhesive incorporated onto or in an inert substrate.

Removed restriction 2: OAC 3745-21-01(X)(24): "Finishing material" means a coating used in the wood furniture manufacturing industry. Such materials include, but are not limited to, stains, basecoats, washcoats, enamels, sealers, and topcoats. Under rule 3745-21-15 of the Administrative Code, adhesives and nonpermanent final finish materials shall not be considered finishing materials. Changed to "Finishing material" means a coating used in the wood furniture manufacturing industry. Such materials include, but are not limited to, stains, basecoats, washcoats, enamels, sealers, and topcoats except that adhesives and nonpermanent final finish materials are not included under rule 3745-21-15 of the Administrative Code.

New restriction: OAC 3745-21-11(D): For any facility having a potential to emit, as described in paragraph (A)(2) of this rule, in excess of one hundred tons of VOC as of the effective date of this rule, the detailed engineering study shall be submitted to the Ohio EPA, division of air pollution control (central office), by not later than one year after the effective date of this rule, and for any facility having a potential to emit in excess of one hundred tons of VOC during any calendar year after the effective date of this rule by not later than one year following the first such calendar year.

Removed restriction 1: OAC 3745-21-01(Y): Except as otherwise provided in this paragraph, the definitions in rule 3745-15-01 of the Administrative Code and paragraph (B) of this rule shall apply to rule 3745-21-16 (removed shall)

Removed restriction 2: OAC 3745-21-01(Z): Except as otherwise provided in this paragraph, the definitions in rule 3745-15-01 of the Administrative Code and paragraph (B) of this rule shall apply to rule 3745-21-17 (removed shall)

New restriction: OAC 3745-21-11(E): Any facility located in Butler, Clermont, Cuyahoga, Geauga, Hamilton, Lake, Lorain, Medina, Portage, Summit, or Warren county for which the director has established a site-specific definition of RACT in this chapter shall submit an updated RACT study to the Ohio environmental protection agency within one year of the effective date of this rule.

Removed restriction 1: OAC 3745-21-01(AA)(13): A material shall not be classified as a bearing coating if (changed "shall not be" to "but is not")

Removed restriction 2: OAC 3745-21-01(AA)(15): "Caulking and smoothing compounds" means semi-solid materials which are applied by hand application methods and are used to aerodynamically smooth exterior vehicle surfaces or fill cavities such as bolt hole accesses. A material shall not be classified as a caulking and smoothing compound if the material can also be classified as a sealant. Changed to "Caulking and smoothing compounds" means semi-solid materials which are applied by hand application methods and are used to aerodynamically smooth exterior vehicle surfaces or fill cavities such as bolt hole accesses, but does not include materials that may also be classified as a sealant.

B. How many existing regulatory restrictions do you propose removing? 0

Rule Summary and Fiscal Analysis

Part B - Local Governments Questions

1. Does the rule increase costs for:

A. Public School Districts	No
B. County Government	Yes
C. Township Government	Yes
D. City and Village Governments	Yes

2. Please estimate the total cost, in dollars, of compliance with the rule for the affected local government(s). If you cannot give a dollar cost, explain how the local government is financially impacted.

This rule requires facilities in the Cincinnati and Cleveland nonattainment areas meeting certain criteria to submit a new or updated RACT study and implement controls consistent with the results of that study. The cost to conduct a RACT study is estimated to be less than \$30,000. Given the many and varied types of processes that are regulated under OAC chapter 3745-21, it is difficult to give an exact cost of compliance for implementing controls. The cost of compliance can range from zero cost for a control technology such as a work practice or raw material change, to a few million dollars for the installation and operation of a mechanical control device.

3. Is this rule the result of a federal government requirement? Yes

- A. If yes, does this rule do more than the federal government requires? No**
- B. If yes, what are the costs, in dollars, to the local government for the regulation that exceeds the federal government requirement?**

Not Applicable

4. Please provide an estimated cost of compliance for the proposed rule if it has an impact on the following:

A. Personnel Costs

See above.

B. New Equipment or Other Capital Costs

See above.

C. Operating Costs

See above.

D. Any Indirect Central Service Costs

See above.

E. Other Costs

See above.

5. Please explain how the local government(s) will be able to pay for the increased costs associated with the rule.

Ohio EPA acknowledges that there will be an increase in costs associated with the expansion of the requirements in the Cincinnati ozone nonattainment area in order to meet mandatory RACT requirements; however, many of the facilities affected by this expansion may already meet the requirements and not incur additional costs. Facilities that are affected will need to adjust their operational and maintenance budgets accordingly. These budgets are typically financed through a general fund.

6. What will be the impact on economic development, if any, as the result of this rule?

These rules are being promulgated to implement federal requirements for the application of reasonably available control technology to source categories of VOC in moderate ozone non-attainment areas. Rules governing VOC for these source types are in effect in many places around the country, and are not unique to the area covered by this rule. Therefore, any potential economic impact in the affected area would be minimal.

Reducing emissions benefits the affected area by providing a cost savings and economic benefit to stakeholders through reduced pollution. Not only does reducing pollution provide for better enjoyment of the states resources through cleaner air but also reduces property damage caused by pollution, reduces illnesses and reduces healthcare costs. The cost benefits, although difficult to quantify, are significant and may exceed the cost incurred by regulated entities required to comply with VOC RACT rules.

Rule Summary and Fiscal Analysis

Part C - Environmental Rule Questions

Pursuant to Am. Sub. H.B. 106 of the 121st General Assembly, prior to adopting a rule or an amendment to a rule dealing with environmental protection, or containing a component dealing with environmental protection, a state agency shall:

- (1) Consult with organizations that represent political subdivisions, environmental interests, business interests, and other persons affected by the proposed rule or amendment.
- (2) Consider documentation relevant to the need for, the environmental benefits or consequences of, other benefits of, and the technological feasibility of the proposed rule or rule amendment.
- (3) Specifically identify whether the proposed rule or rule amendment is being adopted or amended to enable the state to obtain or maintain approval to administer and enforce a federal environmental law or to participate in a federal environmental program, whether the proposed rule or rule amendment is more stringent than its federal counterpart, and, if the proposed rule or rule amendment is more stringent, the rationale for not incorporating its federal counterpart.
- (4) Include with the proposed rule or rule amendment and rule summary and fiscal analysis required to be filed with the Joint Committee on Agency Rule Review information relevant to the previously listed requirements.

(A) Were organizations that represent political subdivisions, environmental interests, business interests, and other persons affected by the proposed rule or amendment consulted? Yes

Please list each contact.

A draft of these rules was released for a 30-day public comment and review period ending June 18, 2021. The rules were released to Ohio EPA's electronic interested parties list, posted on Ohio EPA's regulations website and shared with interested industry parties. Several comments were received on Ohio EPA's rulemaking effort. Ohio EPA's response to comments document can be provided upon request. A copy of Ohio EPA's interested parties distribution list can be made available upon request.

(B) Was documentation that is relevant to the need for, the environmental benefits or consequences of, other benefits of, and the technological feasibility of the proposed rule or amendment considered? Yes

Please list the information provided and attach a copy of each piece of documentation to this form. (A SUMMARY OR INDEX MAY BE ATTACHED IN LIEU OF THE ACTUAL DOCUMENTATION.)

Clean Air Act, USEPA Control Technique Guidance Documents, LSC Style and Formatting Manual, and comments from interested parties.

- (C) **Is the proposed rule or rule amendment being adopted or amended to enable the state to obtain or maintain approval to administer and enforce a federal environmental law or to participate in a federal environmental program? Yes**

Is the proposed rule or rule amendment more stringent than its federal counterpart?
No Not Applicable

- (D) **If this is a rule amendment that is being adopted under a state statute that establishes standards with which the amendment is to comply, is the proposed rule amendment more stringent than the rule that it is proposing to amend? No**

Rule Summary and Fiscal Analysis

Part A - General Questions

Rule Number: 3745-21-15

Rule Type: Amendment

Rule Title/Tagline: Control of volatile organic compound emissions from wood furniture manufacturing operations.

Agency Name: Ohio Environmental Protection Agency

Division:

Address: 50 West Town Street, Suite 700 PO Box 1049 Columbus OH 43216-1049

Contact: Holly Kaloz **Phone:** 614-644-2760

Email: holly.kaloz@epa.ohio.gov

I. Rule Summary

1. **Is this a five year rule review?** Yes
 - A. **What is the rule's five year review date?** 11/29/2021
2. **Is this rule the result of recent legislation?** No
3. **What statute is this rule being promulgated under?** 119.03
4. **What statute(s) grant rule writing authority?** 3704.03(E)
5. **What statute(s) does the rule implement or amplify?** 3704.03(A), 3704.03(E)
6. **What are the reasons for proposing the rule?**

This rule is being filed to fulfill the requirements of ORC 106.03 (5-yr review).

7. **Summarize the rule's content, and if this is an amended rule, also summarize the rule's changes.**

This rule establishes emission control requirements for wood manufacturing operations. This rule is being amended to correct formatting to meet agency standards.

8. **Does the rule incorporate material by reference?** Yes

9. **If the rule incorporates material by reference and the agency claims the material is exempt pursuant to R.C. 121.75, please explain the basis for the exemption and how an individual can find the referenced material.**

This rule contains references to the Ohio Administrative Code (OAC). While copies of these rules and statutes are generally available to the public through libraries and on-line sources, including the Ohio EPA website, ORC 121.76 (A) exempts such references from the provisions of ORC 121.71 through 121.75.

This rule also contains references to the Code of Federal Regulations (CFR). These rules are generally available through libraries, Ohio EPA and U.S. EPA websites. CFR references have also been dated to reference the specific version of the rules. ORC 121.75 (D) exempts such references from the requirements of ORC 121.71 through 121.74.

The rule also contains references to analytical test methods used to determine parameters for materials subject to this rule or other materials utilized by regulators and impacted parties to determine or achieve compliance with these rules. These test methods and materials are commonly known and utilized by laboratories performing this type of analytical work. Copies of these test methods are available in libraries and the websites of the method's supporting organization (ASTM, ANSI, NFPA, NACE, etc.).

Referenced materials are cited, dated and availability noted in paragraph (JJ) of rule 3745-21-01 of the Administrative Code.

10. **If revising or re-filing the rule, please indicate the changes made in the revised or re-filed version of the rule.**

Ohio EPA's website is converting to the State of Ohio IOP platform during the comment period for this rule-making, therefore the link to the rules in the public notice would no longer work. Ohio EPA is revise filing to change the public notice to the updated web location.

II. Fiscal Analysis

11. **Please estimate the increase / decrease in the agency's revenues or expenditures in the current biennium due to this rule.**

This will have no impact on revenues or expenditures.

0.00

Not Applicable

12. What are the estimated costs of compliance for all persons and/or organizations directly affected by the rule?

This rule establishes emission control requirements for wood manufacturing operations.

There is a cost associated with the introduction of a control technology under this rule depending on the control technology chosen. This estimated capital cost, which includes high volume low pressure (HVL) spray guns, cost for extra drying capacity, paint circulation system, and coating material storage which are estimated to be from \$15,000 to \$900,000 depending on the control option chosen. The estimated personnel cost, annually, will range from \$210,000 to \$375,000 depending on the control option chosen. The estimated annual cost for operating cost, the control equipment ranges from \$105,000 to \$280,000 again, depending on the control option chosen. The estimated annual indirect/other cost, which includes the costs of maintaining facilities, equipment, administrative salaries, supplies, and savings; due to less coating used ranges from(\$180,000) to (\$265,000). These cost estimates are based on a study conducted by the USEPA Guideline Series Control of Volatile Organic Compound Emissions from Wood Furniture Manufacturing Operations in April, 1996. Numbers in parentheses indicate a net savings. The dollar amounts have been calculated to reflect 2021 buying power.

This rule has been in effect for at least 15 years. These costs are well established in the industry as existing facilities have already upgraded their equipment to comply with this rule and several years. The amendments being made to this rule do not add any additional requirements to affected facilities. As such, there is no additional cost of compliance associated with the amendments being made to this rule.

13. Does the rule increase local government costs? (If yes, you must complete an RSFA Part B). No

14. Does the rule regulate environmental protection? (If yes, you must complete an RSFA Part C). Yes

15. If the rule imposes a regulation fee, explain how the fee directly relates to your agency's cost in regulating the individual or business.

Not Applicable

III. Common Sense Initiative (CSI) Questions

16. Was this rule filed with the Common Sense Initiative Office? Yes

17. Does this rule have an adverse impact on business? Yes

A. Does this rule require a license, permit, or any other prior authorization to engage in or operate a line of business? Yes

An affected facility is required to submit a notification to the Ohio EPA district office or local air agency in writing that states that the facility is subject to this rule. A new permit is required if the facility does not already possess a complying permit.

B. Does this rule impose a criminal penalty, a civil penalty, or another sanction, or create a cause of action, for failure to comply with its terms? No

C. Does this rule require specific expenditures or the report of information as a condition of compliance? Yes

The rule requires periodic submission of reports that typically include deviations from requirements and exceedances of emissions limits. These costs are discussed in the fiscal analysis for this rule.

D. Is it likely that the rule will directly reduce the revenue or increase the expenses of the lines of business of which it will apply or applies? No

IV. Regulatory Restrictions (This section only applies to agencies indicated in R.C. 121.95 (A))

18. Are you adding a new or removing an existing regulatory restriction as defined in R.C. 121.95? No

A. How many new regulatory restrictions do you propose adding?

Not Applicable

B. How many existing regulatory restrictions do you propose removing?

Not Applicable

Rule Summary and Fiscal Analysis

Part C - Environmental Rule Questions

Pursuant to Am. Sub. H.B. 106 of the 121st General Assembly, prior to adopting a rule or an amendment to a rule dealing with environmental protection, or containing a component dealing with environmental protection, a state agency shall:

- (1) Consult with organizations that represent political subdivisions, environmental interests, business interests, and other persons affected by the proposed rule or amendment.
- (2) Consider documentation relevant to the need for, the environmental benefits or consequences of, other benefits of, and the technological feasibility of the proposed rule or rule amendment.
- (3) Specifically identify whether the proposed rule or rule amendment is being adopted or amended to enable the state to obtain or maintain approval to administer and enforce a federal environmental law or to participate in a federal environmental program, whether the proposed rule or rule amendment is more stringent than its federal counterpart, and, if the proposed rule or rule amendment is more stringent, the rationale for not incorporating its federal counterpart.
- (4) Include with the proposed rule or rule amendment and rule summary and fiscal analysis required to be filed with the Joint Committee on Agency Rule Review information relevant to the previously listed requirements.

(A) Were organizations that represent political subdivisions, environmental interests, business interests, and other persons affected by the proposed rule or amendment consulted? Yes

Please list each contact.

A draft of these rules was released for a 30-day public comment and review period ending June 18, 2021. The rules were released to Ohio EPA's electronic interested parties list, posted on Ohio EPA's regulations website and shared with interested industry parties. Several comments were received on Ohio EPA's rulemaking effort. Ohio EPA's response to comments document can be provided upon request. A copy of Ohio EPA's interested parties distribution list can be made available upon request.

(B) Was documentation that is relevant to the need for, the environmental benefits or consequences of, other benefits of, and the technological feasibility of the proposed rule or amendment considered? Yes

Please list the information provided and attach a copy of each piece of documentation to this form. (A SUMMARY OR INDEX MAY BE ATTACHED IN LIEU OF THE ACTUAL DOCUMENTATION.)

Clean Air Act, USEPA Control Technique Guidance Documents, LSC Style and Formatting Manual, and comments from interested parties.

- (C) **Is the proposed rule or rule amendment being adopted or amended to enable the state to obtain or maintain approval to administer and enforce a federal environmental law or to participate in a federal environmental program? Yes**

Is the proposed rule or rule amendment more stringent than its federal counterpart?
No Not Applicable

- (D) **If this is a rule amendment that is being adopted under a state statute that establishes standards with which the amendment is to comply, is the proposed rule amendment more stringent than the rule that it is proposing to amend? No**

Rule Summary and Fiscal Analysis

Part A - General Questions

Rule Number: 3745-21-18

Rule Type: Amendment

Rule Title/Tagline: Commercial motor vehicle and mobile equipment refinishing operations.

Agency Name: Ohio Environmental Protection Agency

Division:

Address: 50 West Town Street, Suite 700 PO Box 1049 Columbus OH 43216-1049

Contact: Holly Kaloz **Phone:** 614-644-2760

Email: holly.kaloz@epa.ohio.gov

I. Rule Summary

1. **Is this a five year rule review?** Yes
 - A. **What is the rule's five year review date?** 11/29/2021
2. **Is this rule the result of recent legislation?** No
3. **What statute is this rule being promulgated under?** 119.03
4. **What statute(s) grant rule writing authority?** 3704.03(E)
5. **What statute(s) does the rule implement or amplify?** 3704.03(A), 3704.03(E)
6. **What are the reasons for proposing the rule?**

This rule is being filed to fulfill the requirements of ORC 106.03 (5-yr review).

7. **Summarize the rule's content, and if this is an amended rule, also summarize the rule's changes.**

This rule establishes emission control requirements for autobody repaint shops. This rule is being amended to correct formatting to meet agency and LSC standards and to remove unnecessary restriction language from the rule.

8. **Does the rule incorporate material by reference?** Yes

9. **If the rule incorporates material by reference and the agency claims the material is exempt pursuant to R.C. 121.75, please explain the basis for the exemption and how an individual can find the referenced material.**

This rule contains references to the Ohio Administrative Code (OAC). While copies of these rules and statutes are generally available to the public through libraries and on-line sources, including the Ohio EPA website, ORC 121.76 (A) exempts such references from the provisions of ORC 121.71 through 121.75.

The rule also contains references to analytical test methods used to determine parameters for materials subject to this rule or other materials utilized by regulators and impacted parties to determine or achieve compliance with these rules. These test methods and materials are commonly known and utilized by laboratories performing this type of analytical work. Copies of these test methods are available in libraries and the websites of the method's supporting organization (ASTM, ANSI, NFPA, NACE, etc.).

Referenced materials are cited, dated and availability noted in paragraph (JJ) of rule 3745-21-01 of the Administrative Code.

10. **If revising or re-filing the rule, please indicate the changes made in the revised or re-filed version of the rule.**

Ohio EPA's website is converting to the State of Ohio IOP platform during the comment period for this rule-making, therefore the link to the rules in the public notice would no longer work. Ohio EPA is revise filing to change the public notice to the updated web location.

II. **Fiscal Analysis**

11. **Please estimate the increase / decrease in the agency's revenues or expenditures in the current biennium due to this rule.**

This will have no impact on revenues or expenditures.

0.00

Not Applicable

12. **What are the estimated costs of compliance for all persons and/or organizations directly affected by the rule?**

This rule establishes emission control requirements for autobody repaint shops. This rule has been in effect for 15+ years and all existing facilities have adopted controls to comply with the requirements of this rule. The original cost of compliance with this rule was approximately \$200-\$400 per coating spray gun replaced, although the cost saving in reduced coating usage through more efficient application techniques provided some offset to the cost.

The amendments being made to this rule do not add any additional requirements to affected facilities. As such, there is no additional cost of compliance associated with the amendments being made to this rule.

13. **Does the rule increase local government costs? (If yes, you must complete an RSFA Part B).** No
14. **Does the rule regulate environmental protection? (If yes, you must complete an RSFA Part C).** Yes
15. **If the rule imposes a regulation fee, explain how the fee directly relates to your agency's cost in regulating the individual or business.**

Not Applicable

III. Common Sense Initiative (CSI) Questions

16. **Was this rule filed with the Common Sense Initiative Office?** Yes
17. **Does this rule have an adverse impact on business?** Yes
 - A. **Does this rule require a license, permit, or any other prior authorization to engage in or operate a line of business?** No
 - B. **Does this rule impose a criminal penalty, a civil penalty, or another sanction, or create a cause of action, for failure to comply with its terms?** No
 - C. **Does this rule require specific expenditures or the report of information as a condition of compliance?** Yes

The rule requires periodic submission of reports that typically include deviations from requirements and exceedances of emissions limits. These costs are discussed in the fiscal analysis for this rule.

- D. Is it likely that the rule will directly reduce the revenue or increase the expenses of the lines of business of which it will apply or applies? No

IV. Regulatory Restrictions (This section only applies to agencies indicated in R.C. 121.95 (A))

18. Are you adding a new or removing an existing regulatory restriction as defined in R.C. 121.95? Yes

A. How many new regulatory restrictions do you propose adding? 0

B. How many existing regulatory restrictions do you propose removing? 3

Removed restriction: OAC 3745-21-18(C)(5): Ensure that the spray guns used to apply mobile equipment repair and refinishing coatings shall be are cleaned by one of the following: (changed "shall be" to "are")

Removed restriction: OAC 3745-21-18(E)(1): The documentation also shall verify (changed to ", and verify)

Removed restriction: OAC 3745-21-18(E)(1): This documentation shall be submitted to the appropriate Ohio EPA district office or local air agency. (added recipient to previous sentence)

Rule Summary and Fiscal Analysis

Part C - Environmental Rule Questions

Pursuant to Am. Sub. H.B. 106 of the 121st General Assembly, prior to adopting a rule or an amendment to a rule dealing with environmental protection, or containing a component dealing with environmental protection, a state agency shall:

- (1) Consult with organizations that represent political subdivisions, environmental interests, business interests, and other persons affected by the proposed rule or amendment.
- (2) Consider documentation relevant to the need for, the environmental benefits or consequences of, other benefits of, and the technological feasibility of the proposed rule or rule amendment.
- (3) Specifically identify whether the proposed rule or rule amendment is being adopted or amended to enable the state to obtain or maintain approval to administer and enforce a federal environmental law or to participate in a federal environmental program, whether the proposed rule or rule amendment is more stringent than its federal counterpart, and, if the proposed rule or rule amendment is more stringent, the rationale for not incorporating its federal counterpart.
- (4) Include with the proposed rule or rule amendment and rule summary and fiscal analysis required to be filed with the Joint Committee on Agency Rule Review information relevant to the previously listed requirements.

(A) Were organizations that represent political subdivisions, environmental interests, business interests, and other persons affected by the proposed rule or amendment consulted? Yes

Please list each contact.

A draft of these rules was released for a 30-day public comment and review period ending June 18, 2021. The rules were released to Ohio EPA's electronic interested parties list, posted on Ohio EPA's regulations website and shared with interested industry parties. Several comments were received on Ohio EPA's rulemaking effort. Ohio EPA's response to comments document can be provided upon request. A copy of Ohio EPA's interested parties distribution list can be made available upon request.

(B) Was documentation that is relevant to the need for, the environmental benefits or consequences of, other benefits of, and the technological feasibility of the proposed rule or amendment considered? Yes

Please list the information provided and attach a copy of each piece of documentation to this form. (A SUMMARY OR INDEX MAY BE ATTACHED IN LIEU OF THE ACTUAL DOCUMENTATION.)

Clean Air Act, USEPA Control Technique Guidance Documents, LSC Style and Formatting Manual, and comments from interested parties.

- (C) **Is the proposed rule or rule amendment being adopted or amended to enable the state to obtain or maintain approval to administer and enforce a federal environmental law or to participate in a federal environmental program? Yes**

Is the proposed rule or rule amendment more stringent than its federal counterpart?
No Not Applicable

- (D) **If this is a rule amendment that is being adopted under a state statute that establishes standards with which the amendment is to comply, is the proposed rule amendment more stringent than the rule that it is proposing to amend? No**

Rule Summary and Fiscal Analysis

Part A - General Questions

Rule Number: 3745-21-19

Rule Type: Amendment

Rule Title/Tagline: Control of volatile organic compound emissions from aerospace manufacturing and rework facilities.

Agency Name: Ohio Environmental Protection Agency

Division:

Address: 50 West Town Street, Suite 700 PO Box 1049 Columbus OH 43216-1049

Contact: Holly Kaloz **Phone:** 614-644-2760

Email: holly.kaloz@epa.ohio.gov

I. Rule Summary

1. **Is this a five year rule review?** Yes
 - A. **What is the rule's five year review date?** 11/29/2021
2. **Is this rule the result of recent legislation?** No
3. **What statute is this rule being promulgated under?** 119.03
4. **What statute(s) grant rule writing authority?** 3704.03(E)
5. **What statute(s) does the rule implement or amplify?** 3704.03(A), 3704.03(E)
6. **What are the reasons for proposing the rule?**

This rule is being filed to fulfill the requirements of ORC 106.03 (5-yr review) and to adopt mandatory Reasonably Available Control Technology (RACT) requirements for the Cincinnati and Cleveland 2015 ozone nonattainment areas.

7. **Summarize the rule's content, and if this is an amended rule, also summarize the rule's changes.**

This rule establishes emission control requirements for the aerospace manufacturing industry. This rule is being amended to expand CTG requirements to the Cincinnati nonattainment area.

8. **Does the rule incorporate material by reference? No**
9. **If the rule incorporates material by reference and the agency claims the material is exempt pursuant to R.C. 121.75, please explain the basis for the exemption and how an individual can find the referenced material.**

Not Applicable

10. **If revising or re-filing the rule, please indicate the changes made in the revised or re-filed version of the rule.**

Ohio EPA's website is converting to the State of Ohio IOP platform during the comment period for this rule-making, therefore the link to the rules in the public notice would no longer work. Ohio EPA is revise filing to change the public notice to the updated web location.

II. Fiscal Analysis

11. **Please estimate the increase / decrease in the agency's revenues or expenditures in the current biennium due to this rule.**

This will have no impact on revenues or expenditures.

0.00

Not Applicable

12. **What are the estimated costs of compliance for all persons and/or organizations directly affected by the rule?**

OAC Chapter 3745-21 has been in the OAC since 1972. The rules have evolved over the years to address requirements in the Clean Air Act to develop regulations as part of an effort to achieve the NAAQS for CO and ozone within the state. These rules and additional technical support were submitted to U.S. EPA for review and approval as part of the SIP.

This Chapter has been modified over the years to incorporate requirements for categories of sources for which U.S. EPA has indicated that RACT should apply. In

general, the levels of control that are available have been evaluated and presented in a series of CTGs issued by U.S. EPA. There are also rules based on information provided by U.S. EPA for other sources which were identified as non-CTG RACT.

Given the many and varied types of processes that are regulated under OAC chapter 3745-21, it is difficult to give an exact cost of compliance with the rules in this chapter in a limited space. The cost of compliance with these rules can range from zero cost for a control technology such as a work practice or raw material change, to a few million dollars for the installation and operation of a mechanical control device. As part of the permitting process, facilities can perform a RACT analysis which allows them to determine, based on all technologies available, the best and most cost-effective control strategy for their facility.

This rule has been in effect for several years. Most of the costs associated with compliance with the existing requirements of this rule have been addressed in previous rulemakings and have been well established in the industry. There may be some additional cost of compliance related to the expansion of the requirements in the Cincinnati ozone nonattainment area in order to meet mandatory RACT requirements; however, many of the facilities affected by this expansion may already meet the requirements and not incur additional costs.

It should be noted that CTG based rules similar to Ohio's rules can also be found in Ohio's neighbor states and in any state containing a moderate ozone non-attainment area. Facilities wishing to locate in these types of areas will need to meet these requirements in all states.

13. **Does the rule increase local government costs? (If yes, you must complete an RSFA Part B). Yes**
14. **Does the rule regulate environmental protection? (If yes, you must complete an RSFA Part C). Yes**
15. **If the rule imposes a regulation fee, explain how the fee directly relates to your agency's cost in regulating the individual or business.**

Not Applicable

III. Common Sense Initiative (CSI) Questions

16. **Was this rule filed with the Common Sense Initiative Office? Yes**
17. **Does this rule have an adverse impact on business? Yes**

- A. Does this rule require a license, permit, or any other prior authorization to engage in or operate a line of business? Yes**

An affected facility is required to submit a notification to the Ohio EPA district office or local air agency in writing that states that the facility is subject to this rule. A new permit is required if the facility does not already possess a complying permit.

- B. Does this rule impose a criminal penalty, a civil penalty, or another sanction, or create a cause of action, for failure to comply with its terms? No**

- C. Does this rule require specific expenditures or the report of information as a condition of compliance? Yes**

The rule requires periodic submission of reports that typically include deviations from requirements and exceedances of emissions limits. These costs are discussed in the fiscal analysis for this rule.

- D. Is it likely that the rule will directly reduce the revenue or increase the expenses of the lines of business of which it will apply or applies? No**

IV. Regulatory Restrictions (This section only applies to agencies indicated in R.C. 121.95 (A))

- 18. Are you adding a new or removing an existing regulatory restriction as defined in R.C. 121.95? Yes**

- A. How many new regulatory restrictions do you propose adding? 4**

New restriction: OAC 3745-21-19(L)(1): The owner or operator of an aerospace manufacturing or rework facility that is subject to this rule, is located in located in Ashtabula, Cuyahoga, Geauga, Lake, Lorain, Medina, Portage, or Summit county, and has an initial startup of coating or cleaning operations before August 25, 2008 shall notify the appropriate Ohio EPA district office or local air agency in writing that the facility is subject to this rule not later than October 24, 2008, providing the information specified in paragraph (L)(5) of this rule.

Removed restriction 1: OAC 3745-21-01(BB)(13): "Pleasure craft" means any marine or fresh-water vessel used by individuals for noncommercial, nonmilitary, and recreational purposes that is less than twenty meters

in length. A vessel rented exclusively to or chartered by individuals for such purposes shall be considered a pleasure craft. Changed to "Pleasure craft" means any marine or fresh-water vessel used by individuals for noncommercial, nonmilitary, and recreational purposes that is less than twenty meters in length including vessels rented exclusively to or chartered by individuals for such purposes.

Removed restriction 2: OAC 3745-21-01(GG)(40)(a): The products shall meet both the applicable flame spread requirements and the applicable smoke requirements. (removed "shall meet")

New restriction: OAC 3745-21-19(L)(2): The owner or operator of an aerospace manufacturing or rework facility that is subject to this rule, is located in Ashtabula, Cuyahoga, Geauga, Lake, Lorain, Medina, Portage, or Summit county, and has an initial startup of coating or cleaning operations on or after August 25, 2008 shall notify the appropriate Ohio EPA district office or local air agency in writing that the facility is subject to this rule not later than either the date of initial startup of the facility's coating or cleaning operations or October 24, 2008 (whichever is later), providing the information specified in paragraph (L)(5) of this rule. The application for a permit-to-install under rule 3745-31-02 of the Administrative Code may be used to fulfill the notification requirements of this paragraph.

Removed restriction 1: OAC 3745-21-01(GG)(40)(b): Interior or exterior building application products shall meet an ASTM... (removed "shall meet")

Removed restriction 2: OAC 3745-21-01(GG)(40)(c): Mass transit application products shall meet an ASTM... (removed "shall meet")

New restriction: OAC 3745-21-19(L)(3): The owner or operator of an aerospace manufacturing or rework facility that is subject to this rule, is located in Butler, Clermont, Hamilton or Warren county, and has an initial startup of coating or cleaning operations before the effective date of this rule shall notify the appropriate Ohio EPA district office or local air agency in writing that the facility is subject to this rule not later than sixty days after the effective date of this rule, providing the information specified in paragraph (L)(5) of this rule.

Removed restriction 1: OAC 3745-21-01(GG)(40)(d): Duct application products shall meet an ASTM... (removed "shall meet")

Removed restriction 2: OAC 3745-21-01(GG)(51): In addition, the device shall be is operated according to the manufacturer's directions (replaced "shall be" with "is")

New restriction: OAC 3745-21-19(L)(4): The owner or operator of an aerospace manufacturing or rework facility that is subject to this rule, is located in Butler, Clermont, Hamilton or Warren county, and has an initial startup of coating or cleaning operations on or after the effective date of this rule shall notify the appropriate Ohio EPA district office or local air agency in writing that the facility is subject to this rule not later than either the date of initial startup of the facility's coating or cleaning operations or sixty days after the effective date of this rule (whichever is later), providing the information specified in paragraph (L)(5) of this rule. The application for a permit-to-install under rule 3745-31-02 of the Administrative Code may be used to fulfill the notification requirements of this paragraph.

Removed restriction 1: OAC 3745-21-01(GG)(54): ...and the manufacturing schedule shall be based on... (removed "shall be")

Removed restriction 2: OAC 3745-21-04(B)(1)(a): Such certification shall include: equipment description, Ohio EPA permit application number (if assigned), and all necessary data (consistent with the appropriate permit application appendices or emission activity category forms) and calculations which confirm the compliance status. (changed to list form and changed "shall include" to "including the following")

B. How many existing regulatory restrictions do you propose removing? 5

Removed restriction: OAC 3745-21-19(L)(5): The owner or operator of an aerospace manufacturing or rework facility that is subject to this rule and that has an initial startup of coating or cleaning operations before August 25, 2008 shall notify the appropriate Ohio EPA district office or local air agency in writing that the facility is subject to this rule. (moved)

Removed restriction: OAC 3745-21-19(L)(5): The notification, which shall be submitted not later than October 24, 2008. (moved)

Removed restriction: OAC 3745-21-19(L)(2): The owner or operator of an aerospace manufacturing or rework facility that is subject to this rule and that has an initial startup of coating or cleaning operations on or after August 25, 2008 shall notify the appropriate Ohio EPA district office or local air agency in writing that the facility is subject to this rule. (moved)

Removed restriction: OAC 3745-21-19(L)(2): The notification, which shall be submitted not later than either the date of initial startup of the facility's coating or cleaning operations or October 24, 2008 (whichever is later) (moved)

Removed restriction: OAC 3745-21-19(L)(2): ...shall provide the information listed under paragraph (L)(1) of this rule. (moved)

Rule Summary and Fiscal Analysis

Part B - Local Governments Questions

1. Does the rule increase costs for:

A. Public School Districts	No
B. County Government	Yes
C. Township Government	Yes
D. City and Village Governments	Yes

2. Please estimate the total cost, in dollars, of compliance with the rule for the affected local government(s). If you cannot give a dollar cost, explain how the local government is financially impacted.

OAC Chapter 3745-21 has been in the OAC since 1972. The rules have evolved over the years to address requirements in the Clean Air Act to develop regulations as part of an effort to achieve the NAAQS for CO and ozone within the state. These rules and additional technical support were submitted to U.S. EPA for review and approval as part of the SIP.

This Chapter has been modified over the years to incorporate requirements for categories of sources for which U.S. EPA has indicated that RACT should apply. In general, the levels of control that are available have been evaluated and presented in a series of CTGs issued by U.S. EPA. There are also rules based on information provided by U.S. EPA for other sources which were identified as non-CTG RACT.

Given the many and varied types of processes that are regulated under OAC chapter 3745-21, it is difficult to give an exact cost of compliance with the rules in this chapter in a limited space. The cost of compliance with these rules can range from zero cost for a control technology such as a work practice or raw material change, to a few million dollars for the installation and operation of a mechanical control device. As part of the permitting process, facilities can perform a RACT analysis which allows them to determine, based on all technologies available, the best and most cost-effective control strategy for their facility.

This rule has been in effect for several years. Most of the costs associated with compliance with the existing requirements of this rule have been addressed in previous rulemakings and have been well established in the industry. There may be some additional cost of compliance related to the expansion of the requirements in the

Cincinnati ozone nonattainment area in order to meet mandatory RACT requirements; however, many of the facilities affected by this expansion may already meet the requirements and not incur additional costs.

It should be noted that CTG based rules similar to Ohio's rules can also be found in Ohio's neighbor states and in any state containing a moderate ozone non-attainment area. Facilities wishing to locate in these types of areas will need to meet these requirements in all states.

3. **Is this rule the result of a federal government requirement? Yes**
 - A. **If yes, does this rule do more than the federal government requires? No**
 - B. **If yes, what are the costs, in dollars, to the local government for the regulation that exceeds the federal government requirement?**

Not Applicable
4. **Please provide an estimated cost of compliance for the proposed rule if it has an impact on the following:**
 - A. **Personnel Costs**

See above.
 - B. **New Equipment or Other Capital Costs**

See above.
 - C. **Operating Costs**

See above.
 - D. **Any Indirect Central Service Costs**

See above.
 - E. **Other Costs**

See above.
5. **Please explain how the local government(s) will be able to pay for the increased costs associated with the rule.**

Ohio EPA acknowledges that there will be an increase in costs associated with the expansion of the requirements in the Cincinnati ozone nonattainment area in order

to meet mandatory RACT requirements; however, many of the facilities affected by this expansion may already meet the requirements and not incur additional costs. Facilities that are affected will need to adjust their operational and maintenance budgets accordingly. These budgets are typically financed through a general fund.

6. What will be the impact on economic development, if any, as the result of this rule?

These rules are being promulgated to implement federal requirements for the application of reasonably available control technology to source categories of VOC in moderate ozone non-attainment areas. Rules governing VOC for these source types are in effect in many places around the country, and are not unique to the area covered by this rule. Therefore, any potential economic impact in the affected area would be minimal.

Reducing emissions benefits the affected area by providing a cost savings and economic benefit to stakeholders through reduced pollution. Not only does reducing pollution provide for better enjoyment of the states resources through cleaner air but also reduces property damage caused by pollution, reduces illnesses and reduces healthcare costs. The cost benefits, although difficult to quantify, are significant and may exceed the cost incurred by regulated entities required to comply with VOC RACT rules.

Rule Summary and Fiscal Analysis

Part C - Environmental Rule Questions

Pursuant to Am. Sub. H.B. 106 of the 121st General Assembly, prior to adopting a rule or an amendment to a rule dealing with environmental protection, or containing a component dealing with environmental protection, a state agency shall:

- (1) Consult with organizations that represent political subdivisions, environmental interests, business interests, and other persons affected by the proposed rule or amendment.
- (2) Consider documentation relevant to the need for, the environmental benefits or consequences of, other benefits of, and the technological feasibility of the proposed rule or rule amendment.
- (3) Specifically identify whether the proposed rule or rule amendment is being adopted or amended to enable the state to obtain or maintain approval to administer and enforce a federal environmental law or to participate in a federal environmental program, whether the proposed rule or rule amendment is more stringent than its federal counterpart, and, if the proposed rule or rule amendment is more stringent, the rationale for not incorporating its federal counterpart.
- (4) Include with the proposed rule or rule amendment and rule summary and fiscal analysis required to be filed with the Joint Committee on Agency Rule Review information relevant to the previously listed requirements.

(A) Were organizations that represent political subdivisions, environmental interests, business interests, and other persons affected by the proposed rule or amendment consulted? Yes

Please list each contact.

A draft of these rules was released for a 30-day public comment and review period ending June 18, 2021. The rules were released to Ohio EPA's electronic interested parties list, posted on Ohio EPA's regulations website and shared with interested industry parties. Several comments were received on Ohio EPA's rulemaking effort. Ohio EPA's response to comments document can be provided upon request. A copy of Ohio EPA's interested parties distribution list can be made available upon request.

(B) Was documentation that is relevant to the need for, the environmental benefits or consequences of, other benefits of, and the technological feasibility of the proposed rule or amendment considered? Yes

Please list the information provided and attach a copy of each piece of documentation to this form. (A SUMMARY OR INDEX MAY BE ATTACHED IN LIEU OF THE ACTUAL DOCUMENTATION.)

Clean Air Act, USEPA Control Technique Guidance Documents, LSC Style and Formatting Manual, and comments from interested parties.

- (C) **Is the proposed rule or rule amendment being adopted or amended to enable the state to obtain or maintain approval to administer and enforce a federal environmental law or to participate in a federal environmental program? Yes**

Is the proposed rule or rule amendment more stringent than its federal counterpart?
No Not Applicable

- (D) **If this is a rule amendment that is being adopted under a state statute that establishes standards with which the amendment is to comply, is the proposed rule amendment more stringent than the rule that it is proposing to amend? No**

Rule Summary and Fiscal Analysis

Part A - General Questions

Rule Number: 3745-21-20

Rule Type: Amendment

Rule Title/Tagline: Control of volatile organic emissions from shipbuilding and ship repair operations (marine coatings).

Agency Name: Ohio Environmental Protection Agency

Division:

Address: 50 West Town Street, Suite 700 PO Box 1049 Columbus OH 43216-1049

Contact: Holly Kaloz **Phone:** 614-644-2760

Email: holly.kaloz@epa.ohio.gov

I. Rule Summary

1. **Is this a five year rule review?** Yes
 - A. **What is the rule's five year review date?** 11/29/2021
2. **Is this rule the result of recent legislation?** No
3. **What statute is this rule being promulgated under?** 119.03
4. **What statute(s) grant rule writing authority?** 3704.03(E)
5. **What statute(s) does the rule implement or amplify?** 3704.03(A), 3704.03(E)
6. **What are the reasons for proposing the rule?**

This rule is being filed to fulfill the requirements of ORC 106.03 (5-yr review) and to adopt mandatory Reasonably Available Control Technology (RACT) requirements for the Cincinnati and Cleveland 2015 ozone nonattainment areas.

7. **Summarize the rule's content, and if this is an amended rule, also summarize the rule's changes.**

This rule establishes emission control requirements for the VOC content of marine coatings used in shipbuilding and ship repair operations. This rule is being amended to expand CTG requirements to the Cincinnati nonattainment area.

- 8. Does the rule incorporate material by reference? Yes**
- 9. If the rule incorporates material by reference and the agency claims the material is exempt pursuant to R.C. 121.75, please explain the basis for the exemption and how an individual can find the referenced material.**

This rule contains references to the Ohio Administrative Code (OAC). While copies of these rules and statutes are generally available to the public through libraries and on-line sources, including the Ohio EPA website, ORC 121.76 (A) exempts such references from the provisions of ORC 121.71 through 121.75.

This rule also contains references to the Code of Federal Regulations (CFR). These rules are generally available through libraries, Ohio EPA and U.S. EPA websites. CFR references have also been dated to reference the specific version of the rules. ORC 121.75 (D) exempts such references from the requirements of ORC 121.71 through 121.74.

This rule also contains references to the United States Code (USC), the Federal Insecticide, Rodenticide, and Fungicide Act, and the Clean Air Act. These rules and Acts are generally available through libraries, Ohio EPA and Government Printing Office's websites. USC references have also been dated to reference the specific version of the rules. ORC 121.75(D) exempts such references from the requirements of ORC 121.71 through 121.74.

The rule also contains references to analytical test methods used to determine parameters for materials subject to this rule or other materials utilized by regulators and impacted parties to determine or achieve compliance with these rules. These test methods and materials are commonly known and utilized by laboratories performing this type of analytical work. Copies of these test methods are available in libraries and the websites of the method's supporting organization (ASTM, ANSI, NFPA, NACE, etc.).

Referenced materials are cited, dated and availability noted in paragraph (JJ) of rule 3745-21-01 of the Administrative Code.

- 10. If revising or re-filing the rule, please indicate the changes made in the revised or re-filed version of the rule.**

Ohio EPA's website is converting to the State of Ohio IOP platform during the comment period for this rule-making, therefore the link to the rules in the public notice would no longer work. Ohio EPA is revise filing to change the public notice to the updated web location.

II. Fiscal Analysis

- 11. Please estimate the increase / decrease in the agency's revenues or expenditures in the current biennium due to this rule.**

This will have no impact on revenues or expenditures.

0.00

Not Applicable

- 12. What are the estimated costs of compliance for all persons and/or organizations directly affected by the rule?**

OAC Chapter 3745-21 has been in the OAC since 1972. The rules have evolved over the years to address requirements in the Clean Air Act to develop regulations as part of an effort to achieve the NAAQS for CO and ozone within the state. These rules and additional technical support were submitted to U.S. EPA for review and approval as part of the SIP.

This Chapter has been modified over the years to incorporate requirements for categories of sources for which U.S. EPA has indicated that RACT should apply. In general, the levels of control that are available have been evaluated and presented in a series of CTGs issued by U.S. EPA. There are also rules based on information provided by U.S. EPA for other sources which were identified as non-CTG RACT.

Given the many and varied types of processes that are regulated under OAC chapter 3745-21, it is difficult to give an exact cost of compliance with the rules in this chapter in a limited space. The cost of compliance with these rules can range from zero cost for a control technology such as a work practice or raw material change, to a few million dollars for the installation and operation of a mechanical control device. As part of the permitting process, facilities can perform a RACT analysis which allows them to determine, based on all technologies available, the best and most cost-effective control strategy for their facility.

This rule has been in effect for several years. Most of the costs associated with compliance with the existing requirements of this rule have been addressed in

previous rulemakings and have been well established in the industry. There may be some additional cost of compliance related to the expansion of the requirements in the Cincinnati ozone nonattainment area in order to meet mandatory RACT requirements; however, many of the facilities affected by this expansion may already meet the requirements and not incur additional costs.

It should be noted that CTG based rules similar to Ohio's rules can also be found in Ohio's neighbor states and in any state containing a moderate ozone non-attainment area. Facilities wishing to locate in these types of areas will need to meet these requirements in all states.

13. **Does the rule increase local government costs? (If yes, you must complete an RSFA Part B). Yes**
14. **Does the rule regulate environmental protection? (If yes, you must complete an RSFA Part C). Yes**
15. **If the rule imposes a regulation fee, explain how the fee directly relates to your agency's cost in regulating the individual or business.**

Not Applicable

III. Common Sense Initiative (CSI) Questions

16. **Was this rule filed with the Common Sense Initiative Office? Yes**
17. **Does this rule have an adverse impact on business? Yes**
 - A. **Does this rule require a license, permit, or any other prior authorization to engage in or operate a line of business? Yes**

An affected facility is required to submit a notification to the Ohio EPA district office or local air agency in writing that states that the facility is subject to this rule. A new permit is required if the facility does not already possess a complying permit.
 - B. **Does this rule impose a criminal penalty, a civil penalty, or another sanction, or create a cause of action, for failure to comply with its terms? No**
 - C. **Does this rule require specific expenditures or the report of information as a condition of compliance? Yes**

The rule requires periodic submission of reports that typically include deviations from requirements and exceedances of emissions limits. These costs are discussed in the fiscal analysis for this rule.

- D. **Is it likely that the rule will directly reduce the revenue or increase the expenses of the lines of business of which it will apply or applies?** No

IV. Regulatory Restrictions (This section only applies to agencies indicated in R.C. 121.95 (A))

18. **Are you adding a new or removing an existing regulatory restriction as defined in R.C. 121.95? Yes**

- A. **How many new regulatory restrictions do you propose adding?** 4

New restriction: OAC 3745-21-20(L)(1): The owner or operator of a shipbuilding or ship repair operation that is subject to this rule, is located in located in Ashtabula, Cuyahoga, Geauga, Lake, Lorain, Medina, Portage, or Summit county, and has an initial startup of shipbuilding or ship repair operations before August 25, 2008 shall notify the appropriate Ohio EPA district office or local air agency in writing that the facility is subject to this rule not later than October 24, 2008, providing the information specified in paragraph (L)(5) of this rule.

Removed restriction 1: OAC 3745-21-04(B)(1)(a): The certification shall also include an application for a permit authorizing operation of such source in accordance with rule 3745-21-09 of the Administrative Code if such source does not possess an effective permit, or, if applicable. (moved to list form and removed "also shall")

Removed restriction 2: OAC 3745-21-04(B)(1)(b): Such application shall includeâ (changed "shall include" to "including")

New restriction: OAC 3745-21-20(L)(2): The owner or operator of a shipbuilding or ship repair operation that is subject to this rule, is located in Ashtabula, Cuyahoga, Geauga, Lake, Lorain, Medina, Portage, or Summit county, and has an initial startup of shipbuilding or ship repair operations on or after August 25, 2008 shall notify the appropriate Ohio EPA district office or local air agency in writing that the facility is subject to this rule not later than either the date of initial startup of the facility's coating operations or October

24, 2008 (whichever is later), providing the information specified in paragraph (L)(5) of this rule.

Removed restriction 1: OAC 3745-21-04(B)(1)(b): and shall identify all reasonable interim control measures (changed "shall identify" to "identifies")

Removed restriction 2: OAC 3745-21-04(B)(7): the owner or operator shall only submit (changed "shall only submit" to "an operating permit is not required")

New restriction: OAC 3745-21-20(L)(3): The owner or operator of a shipbuilding or ship repair operation that is subject to this rule, is located in Butler, Clermont, Hamilton or Warren county, and has an initial startup of shipbuilding or ship repair operations before the effective date of this rule shall notify the appropriate Ohio EPA district office or local air agency in writing that the facility is subject to this rule not later than sixty days after the effective date of this rule, providing the information specified in paragraph (L)(5) of this rule.

Removed restriction 1: OAC 3745-21-04(C)(45): "PMC Cincinnati, Inc.", facility ID 1431380075, or any subsequent owner or operator of the "PMC Cincinnati, Inc." facility located at 2000 West street, Cincinnati, Ohio shall achieve compliance with paragraph (KK) of rule 3745-21-09 of the Administrative Code by May 25, 1988.

Removed restriction 2: OAC 3745-21-04(C)(53): "Ritrama Duramark", facility ID 1318007355, or any subsequent owner or operator of the "Ritrama Duramark" facility located at 341 Eddy Road, Cleveland, Ohio shall achieve compliance with paragraph (SS) of rule 3745-21-09 of the Administrative Code by March 31, 1993.

New restriction: OAC 3745-21-20(L)(4): The owner or operator of a shipbuilding or ship repair operation that is subject to this rule, is located in Butler, Clermont, Hamilton or Warren county, and has an initial startup of shipbuilding or ship repair operations on or after the effective date of this rule shall notify the appropriate Ohio EPA district office or local air agency in writing that the facility is subject to this rule not later than either the date of initial startup of the facility's coating operations or sixty days after the effective date of this rule (whichever is later), providing the information specified in paragraph (L)(5) of this rule.

Removed restriction 1: OAC 3745-21-07(A)(3): This rule shall apply to any source or operation, for which installation commenced prior to February 18,

2008 and that is specified in paragraphs (K) to (N) of this rule, but shall not apply to VOC emissions (changed "shall not apply to" to "is not applicable to")

Removed restriction 2: OAC 3745-21-07(A)(4): Any emission limitation, control requirement, or operational restriction contained in a permit-to-install, permit-by-rule, permit-to-operate, or Title V permit that is based upon a citation to this rule, except the emission limitations and control requirements specified in paragraphs (K)(2), (K)(4), (L)(2), (M)(2) to (M)(4), (N)(2), and (N)(3) of this rule, shall be void upon February 18, 2008. (changed "shall be void upon" to "expire as of")

B. How many existing regulatory restrictions do you propose removing? 5

Removed restriction: OAC 3745-21-20(L)(5): The owner or operator of shipbuilding or ship repair operations that are subject to this rule and that have an initial startup of shipbuilding or ship repair operations before August 25, 2008 shall notify the appropriate Ohio EPA district office or local air agency in writing that the facility is subject to this rule. (moved)

Removed restriction: OAC 3745-21-20(L)(5): The notification, which shall be submitted not later than October 24, 2008. (moved)

Removed restriction: OAC 3745-21-20(L)(2): The owner or operator of shipbuilding or ship repair operations that are subject to this rule and that have an initial startup of shipbuilding or ship repair operations on or after August 25, 2008 shall notify the appropriate Ohio EPA district office or local air agency in writing that the facility is subject to this rule. (moved)

Removed restriction: OAC 3745-21-20(L)(2): The notification, which shall be submitted not later than either the date of initial startup of the facility's coating operations or October 24, 2008 (whichever is later) (moved)

Removed restriction: OAC 3745-21-20(L)(2): shall provide the information listed under paragraph (L)(1) of this rule. (moved)

Rule Summary and Fiscal Analysis

Part B - Local Governments Questions

1. Does the rule increase costs for:

A. Public School Districts	No
B. County Government	Yes
C. Township Government	Yes
D. City and Village Governments	Yes

2. Please estimate the total cost, in dollars, of compliance with the rule for the affected local government(s). If you cannot give a dollar cost, explain how the local government is financially impacted.

OAC Chapter 3745-21 has been in the OAC since 1972. The rules have evolved over the years to address requirements in the Clean Air Act to develop regulations as part of an effort to achieve the NAAQS for CO and ozone within the state. These rules and additional technical support were submitted to U.S. EPA for review and approval as part of the SIP.

This Chapter has been modified over the years to incorporate requirements for categories of sources for which U.S. EPA has indicated that RACT should apply. In general, the levels of control that are available have been evaluated and presented in a series of CTGs issued by U.S. EPA. There are also rules based on information provided by U.S. EPA for other sources which were identified as non-CTG RACT.

Given the many and varied types of processes that are regulated under OAC chapter 3745-21, it is difficult to give an exact cost of compliance with the rules in this chapter in a limited space. The cost of compliance with these rules can range from zero cost for a control technology such as a work practice or raw material change, to a few million dollars for the installation and operation of a mechanical control device. As part of the permitting process, facilities can perform a RACT analysis which allows them to determine, based on all technologies available, the best and most cost-effective control strategy for their facility.

This rule has been in effect for several years. Most of the costs associated with compliance with the existing requirements of this rule have been addressed in previous rulemakings and have been well established in the industry. There may be some additional cost of compliance related to the expansion of the requirements in the

Cincinnati ozone nonattainment area in order to meet mandatory RACT requirements; however, many of the facilities affected by this expansion may already meet the requirements and not incur additional costs.

It should be noted that CTG based rules similar to Ohio's rules can also be found in Ohio's neighbor states and in any state containing a moderate ozone non-attainment area. Facilities wishing to locate in these types of areas will need to meet these requirements in all states.

3. **Is this rule the result of a federal government requirement? Yes**
 - A. **If yes, does this rule do more than the federal government requires? No**
 - B. **If yes, what are the costs, in dollars, to the local government for the regulation that exceeds the federal government requirement?**

Not Applicable
4. **Please provide an estimated cost of compliance for the proposed rule if it has an impact on the following:**
 - A. **Personnel Costs**

See above.
 - B. **New Equipment or Other Capital Costs**

See above.
 - C. **Operating Costs**

See above.
 - D. **Any Indirect Central Service Costs**

See above.
 - E. **Other Costs**

See above.
5. **Please explain how the local government(s) will be able to pay for the increased costs associated with the rule.**

Ohio EPA acknowledges that there will be an increase in costs associated with the expansion of the requirements in the Cincinnati ozone nonattainment area in order

to meet mandatory RACT requirements; however, many of the facilities affected by this expansion may already meet the requirements and not incur additional costs. Facilities that are affected will need to adjust their operational and maintenance budgets accordingly. These budgets are typically financed through a general fund.

6. What will be the impact on economic development, if any, as the result of this rule?

These rules are being promulgated to implement federal requirements for the application of reasonably available control technology to source categories of VOC in moderate ozone non-attainment areas. Rules governing VOC for these source types are in effect in many places around the country, and are not unique to the area covered by this rule. Therefore, any potential economic impact in the affected area would be minimal.

Reducing emissions benefits the affected area by providing a cost savings and economic benefit to stakeholders through reduced pollution. Not only does reducing pollution provide for better enjoyment of the states resources through cleaner air but also reduces property damage caused by pollution, reduces illnesses and reduces healthcare costs. The cost benefits, although difficult to quantify, are significant and may exceed the cost incurred by regulated entities required to comply with VOC RACT rules.

Rule Summary and Fiscal Analysis

Part C - Environmental Rule Questions

Pursuant to Am. Sub. H.B. 106 of the 121st General Assembly, prior to adopting a rule or an amendment to a rule dealing with environmental protection, or containing a component dealing with environmental protection, a state agency shall:

- (1) Consult with organizations that represent political subdivisions, environmental interests, business interests, and other persons affected by the proposed rule or amendment.
- (2) Consider documentation relevant to the need for, the environmental benefits or consequences of, other benefits of, and the technological feasibility of the proposed rule or rule amendment.
- (3) Specifically identify whether the proposed rule or rule amendment is being adopted or amended to enable the state to obtain or maintain approval to administer and enforce a federal environmental law or to participate in a federal environmental program, whether the proposed rule or rule amendment is more stringent than its federal counterpart, and, if the proposed rule or rule amendment is more stringent, the rationale for not incorporating its federal counterpart.
- (4) Include with the proposed rule or rule amendment and rule summary and fiscal analysis required to be filed with the Joint Committee on Agency Rule Review information relevant to the previously listed requirements.

(A) Were organizations that represent political subdivisions, environmental interests, business interests, and other persons affected by the proposed rule or amendment consulted? Yes

Please list each contact.

A draft of these rules was released for a 30-day public comment and review period ending June 18, 2021. The rules were released to Ohio EPA's electronic interested parties list, posted on Ohio EPA's regulations website and shared with interested industry parties. Several comments were received on Ohio EPA's rulemaking effort. Ohio EPA's response to comments document can be provided upon request. A copy of Ohio EPA's interested parties distribution list can be made available upon request.

(B) Was documentation that is relevant to the need for, the environmental benefits or consequences of, other benefits of, and the technological feasibility of the proposed rule or amendment considered? Yes

Please list the information provided and attach a copy of each piece of documentation to this form. (A SUMMARY OR INDEX MAY BE ATTACHED IN LIEU OF THE ACTUAL DOCUMENTATION.)

Clean Air Act, USEPA Control Technique Guidance Documents, LSC Style and Formatting Manual, and comments from interested parties.

- (C) **Is the proposed rule or rule amendment being adopted or amended to enable the state to obtain or maintain approval to administer and enforce a federal environmental law or to participate in a federal environmental program? Yes**

Is the proposed rule or rule amendment more stringent than its federal counterpart?
No Not Applicable

- (D) **If this is a rule amendment that is being adopted under a state statute that establishes standards with which the amendment is to comply, is the proposed rule amendment more stringent than the rule that it is proposing to amend? No**

Rule Summary and Fiscal Analysis

Part A - General Questions

Rule Number: 3745-21-21

Rule Type: Amendment

Rule Title/Tagline: Storage of volatile organic liquids in fixed roof tanks and external floating roof tanks.

Agency Name: Ohio Environmental Protection Agency

Division:

Address: 50 West Town Street, Suite 700 PO Box 1049 Columbus OH 43216-1049

Contact: Holly Kaloz **Phone:** 614-644-2760

Email: holly.kaloz@epa.ohio.gov

I. Rule Summary

1. **Is this a five year rule review?** Yes
 - A. **What is the rule's five year review date?** 11/29/2021
2. **Is this rule the result of recent legislation?** No
3. **What statute is this rule being promulgated under?** 119.03
4. **What statute(s) grant rule writing authority?** 3704.03(E)
5. **What statute(s) does the rule implement or amplify?** 3704.03(A), 3704.03(E)
6. **What are the reasons for proposing the rule?**

This rule is being filed to fulfill the requirements of ORC 106.03 (5-yr review) and to adopt mandatory Reasonably Available Control Technology (RACT) requirements for the Cincinnati and Cleveland 2015 ozone nonattainment areas.

7. **Summarize the rule's content, and if this is an amended rule, also summarize the rule's changes.**

This rule establishes reduction requirements for certain tanks used for storage of volatile organic liquids. This rule is being amended to expand CTG requirements to the Cincinnati nonattainment area.

- 8. Does the rule incorporate material by reference? Yes**
- 9. If the rule incorporates material by reference and the agency claims the material is exempt pursuant to R.C. 121.75, please explain the basis for the exemption and how an individual can find the referenced material.**

This rule contains references to the Ohio Administrative Code (OAC). While copies of these rules and statutes are generally available to the public through libraries and on-line sources, including the Ohio EPA website, ORC 121.76 (A) exempts such references from the provisions of ORC 121.71 through 121.75.

This rule also contains references to the Code of Federal Regulations (CFR). These rules are generally available through libraries, Ohio EPA and U.S. EPA websites. CFR references have also been dated to reference the specific version of the rules. ORC 121.75 (D) exempts such references from the requirements of ORC 121.71 through 121.74.

The rule also contains references to analytical test methods used to determine parameters for materials subject to this rule or other materials utilized by regulators and impacted parties to determine or achieve compliance with these rules. These test methods and materials are commonly known and utilized by laboratories performing this type of analytical work. Copies of these test methods are available in libraries and the websites of the method's supporting organization (ASTM, ANSI, NFPA, NACE, etc.).

Referenced materials are cited, dated and availability noted in paragraph (JJ) of rule 3745-21-01 of the Administrative Code.

- 10. If revising or re-filing the rule, please indicate the changes made in the revised or re-filed version of the rule.**

Ohio EPA's website is converting to the State of Ohio IOP platform during the comment period for this rule-making, therefore the link to the rules in the public notice would no longer work. Ohio EPA is revise filing to change the public notice to the updated web location.

II. Fiscal Analysis

11. Please estimate the increase / decrease in the agency's revenues or expenditures in the current biennium due to this rule.

This will have no impact on revenues or expenditures.

0.00

Not Applicable

12. What are the estimated costs of compliance for all persons and/or organizations directly affected by the rule?

OAC Chapter 3745-21 has been in the OAC since 1972. The rules have evolved over the years to address requirements in the Clean Air Act to develop regulations as part of an effort to achieve the NAAQS for CO and ozone within the state. These rules and additional technical support were submitted to U.S. EPA for review and approval as part of the SIP.

This Chapter has been modified over the years to incorporate requirements for categories of sources for which U.S. EPA has indicated that RACT should apply. In general, the levels of control that are available have been evaluated and presented in a series of CTGs issued by U.S. EPA. There are also rules based on information provided by U.S. EPA for other sources which were identified as non-CTG RACT.

Given the many and varied types of processes that are regulated under OAC chapter 3745-21, it is difficult to give an exact cost of compliance with the rules in this chapter in a limited space. The cost of compliance with these rules can range from zero cost for a control technology such as a work practice or raw material change, to a few million dollars for the installation and operation of a mechanical control device. As part of the permitting process, facilities can perform a RACT analysis which allows them to determine, based on all technologies available, the best and most cost-effective control strategy for their facility.

This rule has been in effect for several years. Most of the costs associated with compliance with the existing requirements of this rule have been addressed in previous rulemakings and have been well established in the industry. There may be some additional cost of compliance related to the expansion of the requirements in the Cincinnati ozone nonattainment area in order to meet mandatory RACT requirements; however, many of the facilities affected by this expansion may already meet the requirements and not incur additional costs.

It should be noted that CTG based rules similar to Ohio's rules can also be found in Ohio's neighbor states and in any state containing a moderate ozone non-attainment

area. Facilities wishing to locate in these types of areas will need to meet these requirements in all states.

13. **Does the rule increase local government costs? (If yes, you must complete an RSFA Part B). Yes**
14. **Does the rule regulate environmental protection? (If yes, you must complete an RSFA Part C). Yes**
15. **If the rule imposes a regulation fee, explain how the fee directly relates to your agency's cost in regulating the individual or business.**

Not Applicable

III. Common Sense Initiative (CSI) Questions

16. **Was this rule filed with the Common Sense Initiative Office? Yes**
17. **Does this rule have an adverse impact on business? Yes**

- A. **Does this rule require a license, permit, or any other prior authorization to engage in or operate a line of business? Yes**

An affected facility is required to submit a notification to the Ohio EPA district office or local air agency in writing that states that the facility is subject to this rule. A new permit is required if the facility does not already possess a complying permit.

- B. **Does this rule impose a criminal penalty, a civil penalty, or another sanction, or create a cause of action, for failure to comply with its terms? No**
- C. **Does this rule require specific expenditures or the report of information as a condition of compliance? No**
- D. **Is it likely that the rule will directly reduce the revenue or increase the expenses of the lines of business of which it will apply or applies? No**

The rule requires periodic submission of reports that typically include deviations from requirements and exceedances of emissions limits. These costs are discussed in the fiscal analysis for this rule.

IV. Regulatory Restrictions (This section only applies to agencies indicated in R.C. 121.95 (A))

18. Are you adding a new or removing an existing regulatory restriction as defined in R.C. 121.95? Yes

A. How many new regulatory restrictions do you propose adding? 4

New restriction: OAC 3745-21-21(I)(1): The owner or operator of a facility that is subject to this rule, is located in located in Ashtabula, Cuyahoga, Geauga, Lake, Lorain, Medina, Portage, or Summit county, and has an initial startup of a storage tank for volatile organic liquids before August 25, 2008 shall notify the appropriate Ohio EPA district office or local air agency in writing that the volatile organic liquid storage tank is subject to this rule not later than October 24, 2008 (or within sixty days after the volatile organic liquid storage tank becomes subject to this rule), providing the information specified in paragraph (I)(5) of this rule.

Removed restriction 1: OAC 3745-21-07(A)(4): As examples of the applicability of this paragraph, if a permit-to-install, a permit-by-rule, a permit-to-operate, or a Title V permit has been issued prior to February 18, 2008 and contains both a citation to rule 3745-21-07 of the Administrative Code and one of the associated requirements referenced within this comment, the associated requirements contained in such a permit shall be void upon February 18, 2008. (changed "shall be void upon" to "expire as of")

Removed restriction 2: OAC 3745-21-07(A)(4): The associated requirements covered by this comment shall include: (removed shall)

New restriction: OAC 3745-21-21(I)(2): The owner or operator of a facility that is subject to this rule, is located in Ashtabula, Cuyahoga, Geauga, Lake, Lorain, Medina, Portage, or Summit county, and has an initial startup of a storage tank for volatile organic liquids on or after August 25, 2008 shall notify the appropriate Ohio EPA district office or local air agency in writing that the volatile organic liquid storage tank is subject to this rule not later than either the date of initial startup of the the subject coating operation or October 24, 2008 (whichever is later), providing the information specified in paragraph (I) (5) of this rule.

Removed restriction 1: OAC 3745-21-07(A)(5): This rule shall not apply to any source (changed "shall" to "does")

Removed restriction 2: OAC 3745-21-07(A)(6): The use of emissions test data, if available, from a source or operation specified in paragraphs (K) to (N) of this rule shall take precedence over the use of an emission factor approved by the USEPA or the use of emission test data from similar sources or operations. (removed shall)

New restriction: OAC 3745-21-21(I)(3): The owner or operator of a facility that is subject to this rule, is located in Butler, Clermont, Hamilton or Warren county, and has an initial startup of a storage tank for volatile organic liquids before the effective date of this rule shall notify the appropriate Ohio EPA district office or local air agency in writing that the volatile organic liquid storage tank is subject to this rule not later than sixty days after the effective date of this rule, providing the information specified in paragraph (I)(5) of this rule.

Removed restriction 1: OAC 3745-21-07(K)(2)(a): The storage tank shall be equipped with a floating pontoon or double-deck type cover that includes closure seals to enclose any space between the cover's edge and the compartment wall. This control requirement shall not be permitted if the liquid organic material in the tank has a vapor pressure of 12.5 pounds per square inch absolute or greater under actual storage conditions. (Changed to: A floating pontoon or double-deck type cover that includes closure seals to enclose any space between the cover's edge and the compartment wall provided that the liquid organic material in the tank has a vapor pressure of less than 12.5 pounds per square inch absolute under actual storage conditions)

Removed restriction 2: OAC 3745-21-07(K)(2)(a): All tank gauging or sampling devices shall be gas tight except when tank gauging or sampling is taking place. (change "shall be" to "remain")

New restriction: OAC 3745-21-21(I)(4): The owner or operator of a facility that is subject to this rule, is located in Butler, Clermont, Hamilton or Warren county, and has an initial startup of a storage tank for volatile organic liquids on or after the effective date of this rule shall notify the appropriate Ohio EPA district office or local air agency in writing that the volatile organic liquid storage tank is subject to this rule not later than either the date of initial startup of the the volatile organic liquid storage tank or sixty days after the effective date of this rule (whichever is later), providing the information specified in paragraph (I) (5) of this rule.

Removed restriction 1: OAC 3745-21-07(K)(2)(b): The storage tank shall be equipped with a vapor recovery system or control system that reduces the emission of organic compounds into the atmosphere by at least ninety per

cent by weight. (Changed to: A vapor recovery system or control system that reduces the emission of organic compounds into the atmosphere by at least ninety per cent by weight.)

Removed restriction 2: OAC 3745-21-07(K)(2)(b): All tank gauging or sampling devices shall be gas tight except when tank gauging or sampling is taking place. (change "shall be" to "remain")

B. How many existing regulatory restrictions do you propose removing? 5

Removed restriction: OAC 3745-21-21(I)(5): The owner or operator of a facility that is subject to this rule and that operates a storage tank for volatile organic liquids with an initial startup date before August 25, 2008 shall notify the appropriate Ohio EPA district office or local air agency in writing that the volatile organic liquid storage tank is subject to this rule. (moved)

Removed restriction: OAC 3745-21-21(I)(5): The notification, which shall be submitted not later than October 24, 2008. (moved)

Removed restriction: OAC 3745-21-21(I)(2): The owner or operator of a facility that is subject to this rule and that has a volatile organic liquid storage tank with an initial start-up date on or after August 25, 2008 shall notify the appropriate Ohio EPA district office or local air agency in writing that the volatile organic liquid storage tank is subject to this rule. (moved)

Removed restriction: OAC 3745-21-21(I)(2): The notification, which shall be submitted not later than either the date of initial startup of the volatile organic liquid storage tank or October 24, 2008 (whichever is later) (moved)

Removed restriction: OAC 3745-21-21(I)(2): ...shall provide the information listed under paragraph (I)(1) of this rule. (moved)

Rule Summary and Fiscal Analysis

Part B - Local Governments Questions

1. Does the rule increase costs for:

A. Public School Districts	No
B. County Government	Yes
C. Township Government	Yes
D. City and Village Governments	Yes

2. Please estimate the total cost, in dollars, of compliance with the rule for the affected local government(s). If you cannot give a dollar cost, explain how the local government is financially impacted.

OAC Chapter 3745-21 has been in the OAC since 1972. The rules have evolved over the years to address requirements in the Clean Air Act to develop regulations as part of an effort to achieve the NAAQS for CO and ozone within the state. These rules and additional technical support were submitted to U.S. EPA for review and approval as part of the SIP.

This Chapter has been modified over the years to incorporate requirements for categories of sources for which U.S. EPA has indicated that RACT should apply. In general, the levels of control that are available have been evaluated and presented in a series of CTGs issued by U.S. EPA. There are also rules based on information provided by U.S. EPA for other sources which were identified as non-CTG RACT.

Given the many and varied types of processes that are regulated under OAC chapter 3745-21, it is difficult to give an exact cost of compliance with the rules in this chapter in a limited space. The cost of compliance with these rules can range from zero cost for a control technology such as a work practice or raw material change, to a few million dollars for the installation and operation of a mechanical control device. As part of the permitting process, facilities can perform a RACT analysis which allows them to determine, based on all technologies available, the best and most cost-effective control strategy for their facility.

This rule has been in effect for several years. Most of the costs associated with compliance with the existing requirements of this rule have been addressed in previous rulemakings and have been well established in the industry. There may be some additional cost of compliance related to the expansion of the requirements in the

Cincinnati ozone nonattainment area in order to meet mandatory RACT requirements; however, many of the facilities affected by this expansion may already meet the requirements and not incur additional costs.

It should be noted that CTG based rules similar to Ohio's rules can also be found in Ohio's neighbor states and in any state containing a moderate ozone non-attainment area. Facilities wishing to locate in these types of areas will need to meet these requirements in all states.

3. **Is this rule the result of a federal government requirement? Yes**
 - A. **If yes, does this rule do more than the federal government requires? No**
 - B. **If yes, what are the costs, in dollars, to the local government for the regulation that exceeds the federal government requirement?**

Not Applicable
4. **Please provide an estimated cost of compliance for the proposed rule if it has an impact on the following:**
 - A. **Personnel Costs**

See above.
 - B. **New Equipment or Other Capital Costs**

See above.
 - C. **Operating Costs**

See above.
 - D. **Any Indirect Central Service Costs**

See above.
 - E. **Other Costs**

See above.
5. **Please explain how the local government(s) will be able to pay for the increased costs associated with the rule.**

Ohio EPA acknowledges that there will be an increase in costs associated with the expansion of the requirements in the Cincinnati ozone nonattainment area in order

to meet mandatory RACT requirements; however, many of the facilities affected by this expansion may already meet the requirements and not incur additional costs. Facilities that are affected will need to adjust their operational and maintenance budgets accordingly. These budgets are typically financed through a general fund.

6. What will be the impact on economic development, if any, as the result of this rule?

These rules are being promulgated to implement federal requirements for the application of reasonably available control technology to source categories of VOC in moderate ozone non-attainment areas. Rules governing VOC for these source types are in effect in many places around the country, and are not unique to the area covered by this rule. Therefore, any potential economic impact in the affected area would be minimal.

Reducing emissions benefits the affected area by providing a cost savings and economic benefit to stakeholders through reduced pollution. Not only does reducing pollution provide for better enjoyment of the states resources through cleaner air but also reduces property damage caused by pollution, reduces illnesses and reduces healthcare costs. The cost benefits, although difficult to quantify, are significant and may exceed the cost incurred by regulated entities required to comply with VOC RACT rules.

Rule Summary and Fiscal Analysis

Part C - Environmental Rule Questions

Pursuant to Am. Sub. H.B. 106 of the 121st General Assembly, prior to adopting a rule or an amendment to a rule dealing with environmental protection, or containing a component dealing with environmental protection, a state agency shall:

- (1) Consult with organizations that represent political subdivisions, environmental interests, business interests, and other persons affected by the proposed rule or amendment.
- (2) Consider documentation relevant to the need for, the environmental benefits or consequences of, other benefits of, and the technological feasibility of the proposed rule or rule amendment.
- (3) Specifically identify whether the proposed rule or rule amendment is being adopted or amended to enable the state to obtain or maintain approval to administer and enforce a federal environmental law or to participate in a federal environmental program, whether the proposed rule or rule amendment is more stringent than its federal counterpart, and, if the proposed rule or rule amendment is more stringent, the rationale for not incorporating its federal counterpart.
- (4) Include with the proposed rule or rule amendment and rule summary and fiscal analysis required to be filed with the Joint Committee on Agency Rule Review information relevant to the previously listed requirements.

(A) Were organizations that represent political subdivisions, environmental interests, business interests, and other persons affected by the proposed rule or amendment consulted? Yes

Please list each contact.

A draft of these rules was released for a 30-day public comment and review period ending June 18, 2021. The rules were released to Ohio EPA's electronic interested parties list, posted on Ohio EPA's regulations website and shared with interested industry parties. Several comments were received on Ohio EPA's rulemaking effort. Ohio EPA's response to comments document can be provided upon request. A copy of Ohio EPA's interested parties distribution list can be made available upon request.

(B) Was documentation that is relevant to the need for, the environmental benefits or consequences of, other benefits of, and the technological feasibility of the proposed rule or amendment considered? Yes

Please list the information provided and attach a copy of each piece of documentation to this form. (A SUMMARY OR INDEX MAY BE ATTACHED IN LIEU OF THE ACTUAL DOCUMENTATION.)

Clean Air Act, USEPA Control Technique Guidance Documents, LSC Style and Formatting Manual, and comments from interested parties.

- (C) **Is the proposed rule or rule amendment being adopted or amended to enable the state to obtain or maintain approval to administer and enforce a federal environmental law or to participate in a federal environmental program? Yes**

Is the proposed rule or rule amendment more stringent than its federal counterpart?
No Not Applicable

- (D) **If this is a rule amendment that is being adopted under a state statute that establishes standards with which the amendment is to comply, is the proposed rule amendment more stringent than the rule that it is proposing to amend? No**

Rule Summary and Fiscal Analysis

Part A - General Questions

Rule Number: 3745-21-22

Rule Type: Amendment

Rule Title/Tagline: Control of volatile organic compound emissions from offset lithographic printing and letterpress printing facilities.

Agency Name: Ohio Environmental Protection Agency

Division:

Address: 50 West Town Street, Suite 700 PO Box 1049 Columbus OH 43216-1049

Contact: Holly Kaloz **Phone:** 614-644-2760

Email: holly.kaloz@epa.ohio.gov

I. Rule Summary

1. **Is this a five year rule review?** Yes
 - A. **What is the rule's five year review date?** 11/29/2021
2. **Is this rule the result of recent legislation?** No
3. **What statute is this rule being promulgated under?** 119.03
4. **What statute(s) grant rule writing authority?** 3704.03(E)
5. **What statute(s) does the rule implement or amplify?** 3704.03(A), 3704.03(E)
6. **What are the reasons for proposing the rule?**

This rule is being filed to fulfill the requirements of ORC 106.03 (5-yr review) and to adopt mandatory Reasonably Available Control Technology (RACT) requirements for the Cincinnati and Cleveland 2015 ozone nonattainment areas.

7. **Summarize the rule's content, and if this is an amended rule, also summarize the rule's changes.**

This rule identifies VOC emission and control requirements for lithographic printing and letterpress printing facilities. This rule is being amended to expand CTG requirements to the Cincinnati nonattainment area.

- 8. Does the rule incorporate material by reference? Yes**
- 9. If the rule incorporates material by reference and the agency claims the material is exempt pursuant to R.C. 121.75, please explain the basis for the exemption and how an individual can find the referenced material.**

This rule contains references to the Ohio Administrative Code (OAC). While copies of these rules and statutes are generally available to the public through libraries and on-line sources, including the Ohio EPA website, ORC 121.76 (A) exempts such references from the provisions of ORC 121.71 through 121.75.

This rule also contains references to the Code of Federal Regulations (CFR). These rules are generally available through libraries, Ohio EPA and U.S. EPA websites. CFR references have also been dated to reference the specific version of the rules. ORC 121.75 (D) exempts such references from the requirements of ORC 121.71 through 121.74.

The rule also contains references to analytical test methods used to determine parameters for materials subject to this rule or other materials utilized by regulators and impacted parties to determine or achieve compliance with these rules. These test methods and materials are commonly known and utilized by laboratories performing this type of analytical work. Copies of these test methods are available in libraries and the websites of the method's supporting organization (ASTM, ANSI, NFPA, NACE, etc.).

Referenced materials are cited, dated and availability noted in paragraph (JJ) of rule 3745-21-01 of the Administrative Code.

- 10. If revising or re-filing the rule, please indicate the changes made in the revised or re-filed version of the rule.**

Ohio EPA's website is converting to the State of Ohio IOP platform during the comment period for this rule-making, therefore the link to the rules in the public notice would no longer work. Ohio EPA is revise filing to change the public notice to the updated web location.

II. Fiscal Analysis

11. Please estimate the increase / decrease in the agency's revenues or expenditures in the current biennium due to this rule.

This will have no impact on revenues or expenditures.

0.00

Not Applicable

12. What are the estimated costs of compliance for all persons and/or organizations directly affected by the rule?

OAC Chapter 3745-21 has been in the OAC since 1972. The rules have evolved over the years to address requirements in the Clean Air Act to develop regulations as part of an effort to achieve the NAAQS for CO and ozone within the state. These rules and additional technical support were submitted to U.S. EPA for review and approval as part of the SIP.

This Chapter has been modified over the years to incorporate requirements for categories of sources for which U.S. EPA has indicated that RACT should apply. In general, the levels of control that are available have been evaluated and presented in a series of CTGs issued by U.S. EPA. There are also rules based on information provided by U.S. EPA for other sources which were identified as non-CTG RACT.

Given the many and varied types of processes that are regulated under OAC chapter 3745-21, it is difficult to give an exact cost of compliance with the rules in this chapter in a limited space. The cost of compliance with these rules can range from zero cost for a control technology such as a work practice or raw material change, to a few million dollars for the installation and operation of a mechanical control device. As part of the permitting process, facilities can perform a RACT analysis which allows them to determine, based on all technologies available, the best and most cost-effective control strategy for their facility.

This rule has been in effect for several years. Most of the costs associated with compliance with the existing requirements of this rule have been addressed in previous rulemakings and have been well established in the industry. There may be some additional cost of compliance related to the expansion of the requirements in the Cincinnati ozone nonattainment area in order to meet mandatory RACT requirements; however, many of the facilities affected by this expansion may already meet the requirements and not incur additional costs.

It should be noted that CTG based rules similar to Ohio's rules can also be found in Ohio's neighbor states and in any state containing a moderate ozone non-attainment

area. Facilities wishing to locate in these types of areas will need to meet these requirements in all states.

13. **Does the rule increase local government costs? (If yes, you must complete an RSFA Part B). Yes**
14. **Does the rule regulate environmental protection? (If yes, you must complete an RSFA Part C). Yes**
15. **If the rule imposes a regulation fee, explain how the fee directly relates to your agency's cost in regulating the individual or business.**

Not Applicable

III. Common Sense Initiative (CSI) Questions

16. **Was this rule filed with the Common Sense Initiative Office? Yes**
17. **Does this rule have an adverse impact on business? Yes**

- A. **Does this rule require a license, permit, or any other prior authorization to engage in or operate a line of business? Yes**

An affected facility is required to submit a notification to the Ohio EPA district office or local air agency in writing that states that the facility is subject to this rule. A new permit is required if the facility does not already possess a complying permit.

- B. **Does this rule impose a criminal penalty, a civil penalty, or another sanction, or create a cause of action, for failure to comply with its terms? No**

- C. **Does this rule require specific expenditures or the report of information as a condition of compliance? Yes**

The rule requires periodic submission of reports that typically include deviations from requirements and exceedances of emissions limits. These costs are discussed in the fiscal analysis for this rule.

- D. **Is it likely that the rule will directly reduce the revenue or increase the expenses of the lines of business of which it will apply or applies? No**

IV. Regulatory Restrictions (This section only applies to agencies indicated in R.C. 121.95 (A))

18. Are you adding a new or removing an existing regulatory restriction as defined in R.C. 121.95? Yes

A. How many new regulatory restrictions do you propose adding? 4

New restriction: OAC 3745-21-22(J)(1): The owner or operator of an offset lithographic or letterpress printing facility that is subject to this rule, is located in located in Ashtabula, Cuyahoga, Geauga, Lake, Lorain, Medina, Portage, or Summit county, and has an initial startup of an offset lithographic or letterpress printing press before April 2, 2009 shall notify the appropriate Ohio EPA district office or local air agency in writing that the offset lithographic or letterpress printing press is subject to this rule not later than June 1, 2009 (or within sixty days after the offset lithographic or letterpress printing press becomes subject to this rule), providing the information specified in paragraph (J)(5) of this rule.

Removed restriction 1: OAC 3745-21-07(K)(2)(b): The storage tank shall be equipped with a vapor recovery system or control system that reduces the emission of organic compounds into the atmosphere by at least ninety per cent by weight. (Changed to: A vapor recovery system or control system that reduces the emission of organic compounds into the atmosphere by at least ninety per cent by weight.)

Removed restriction 2: OAC 3745-21-07(K)(2)(b): All tank gauging or sampling devices shall be gas tight except when tank gauging or sampling is taking place. (change "shall be" to "remain")

New restriction: OAC 3745-21-22(J)(2): The owner or operator of an offset lithographic or letterpress printing facility that is subject to this rule, is located in Ashtabula, Cuyahoga, Geauga, Lake, Lorain, Medina, Portage, or Summit county, and has an initial startup of an offset lithographic or letterpress printing press on or after April 2, 2009 shall notify the appropriate Ohio EPA district office or local air agency in writing that the offset lithographic or letterpress printing press is subject to this rule not later than either the date of initial startup of the offset lithographic or letterpress printing press or June 1, 2009 (whichever is later), providing the information specified in paragraph (J)(5) of this rule.

Removed restriction 1: OAC 3745-21-07(L)(2)(a): The oil-water separator shall be equipped with a solid cover with all openings sealed and totally enclosing

the liquid contents of the compartment. (Changed to: A solid cover with all openings sealed and totally enclosing the liquid contents of the compartment)

Removed restriction 2: OAC 3745-21-07(L)(2)(a): All gauging and sampling devices shall be gas tight except when gauging or sampling is taking place. (changed "shall be" to "remaining")

New restriction: OAC 3745-21-22(J)(3): The owner or operator of an offset lithographic or letterpress printing facility that is subject to this rule, is located in Butler, Clermont, Hamilton or Warren county, and has an initial startup of an offset lithographic or letterpress printing press before the effective date of this rule shall notify the appropriate Ohio EPA district office or local air agency in writing that the offset lithographic or letterpress printing press is subject to this rule not later than sixty days after the effective date of this rule, providing the information specified in paragraph (J) (5) of this rule.

Removed restriction 1: OAC 3745-21-07(L)(2)(b): The oil-water separator shall be equipped with a floating pontoon or double-deck type cover that includes closure seals to enclose any space between the cover's edge and compartment wall. (Changed to: A floating pontoon or double-deck type cover that includes closure seals to enclose any space between the cover's edge and compartment wall.)

Removed restriction 2: OAC 3745-21-07(L)(2)(b): All gauging and sampling devices shall be gas tight except when gauging or sampling is taking place. (changed "shall be" to "remaining")

New restriction 1: OAC 3745-21-22(J)(4): The owner or operator of an offset lithographic or letterpress printing facility that is subject to this rule, is located in Butler, Clermont, Hamilton or Warren county, and has an initial startup of an offset lithographic or letterpress printing press on or after the effective date of this rule shall notify the appropriate Ohio EPA district office or local air agency in writing that the offset lithographic or letterpress printing press is subject to this rule not later than either the date of initial startup of the offset lithographic or letterpress printing press or sixty days after the effective date of this rule (whichever is later), providing the information specified in paragraph (J)(5) of this rule.

Removed restriction 2: OAC 3745-21-07(L)(2)(c): The oil-water separator shall be equipped with a vapor recovery system that reduces the emission of organic compounds into the atmosphere by at least ninety per cent by weight.

(Changed to: A vapor recovery system that reduces the emission of organic compounds into the atmosphere by at least ninety per cent by weight.)

Removed restriction: OAC 3745-21-07(L)(2)(c): All gauging and sampling devices shall be gas tight except when gauging or sampling is taking place. (changed "shall be" to "remaining")

B. How many existing regulatory restrictions do you propose removing? 5

Removed restriction: OAC 3745-21-22(J)(5): The owner or operator of an offset lithographic or letterpress printing facility that is subject to this rule and that has an offset lithographic or letterpress printing press with an initial startup date before April 2, 2009 of this rule shall notify the Ohio EPA district office or local air agency in writing that the offset lithographic or letterpress printing press is subject to this rule. (moved)

Removed restriction: OAC 3745-21-22(J)(5) The notification, which shall be submitted not later than June 1, 2009 (or within sixty days after the offset lithographic or letterpress printing press becomes subject to this rule) (moved)

Removed restriction: OAC 3745-21-22(J)(2): The owner or operator of an offset lithographic or letterpress printing facility that is subject to this rule and that has an offset lithographic or letterpress printing press with an initial startup date on or after April 2, 2009 of this rule shall notify the Ohio EPA district office or local air agency in writing that the offset lithographic or letterpress printing press is subject to this rule. (moved)

Removed restriction: OAC 3745-21-22(J)(2): The notification, which shall be submitted not later than either the date of initial startup of the offset lithographic or letterpress printing press, or June 1, 2009 (whichever is later) (moved)

Removed restriction: OAC 3745-21-22(J)(2): shall provide the information listed under paragraph (J)(1) of this rule. (moved)

Rule Summary and Fiscal Analysis

Part B - Local Governments Questions

1. Does the rule increase costs for:

A. Public School Districts	No
B. County Government	Yes
C. Township Government	Yes
D. City and Village Governments	Yes

2. Please estimate the total cost, in dollars, of compliance with the rule for the affected local government(s). If you cannot give a dollar cost, explain how the local government is financially impacted.

OAC Chapter 3745-21 has been in the OAC since 1972. The rules have evolved over the years to address requirements in the Clean Air Act to develop regulations as part of an effort to achieve the NAAQS for CO and ozone within the state. These rules and additional technical support were submitted to U.S. EPA for review and approval as part of the SIP.

This Chapter has been modified over the years to incorporate requirements for categories of sources for which U.S. EPA has indicated that RACT should apply. In general, the levels of control that are available have been evaluated and presented in a series of CTGs issued by U.S. EPA. There are also rules based on information provided by U.S. EPA for other sources which were identified as non-CTG RACT.

Given the many and varied types of processes that are regulated under OAC chapter 3745-21, it is difficult to give an exact cost of compliance with the rules in this chapter in a limited space. The cost of compliance with these rules can range from zero cost for a control technology such as a work practice or raw material change, to a few million dollars for the installation and operation of a mechanical control device. As part of the permitting process, facilities can perform a RACT analysis which allows them to determine, based on all technologies available, the best and most cost-effective control strategy for their facility.

This rule has been in effect for several years. Most of the costs associated with compliance with the existing requirements of this rule have been addressed in previous rulemakings and have been well established in the industry. There may be some additional cost of compliance related to the expansion of the requirements in the

Cincinnati ozone nonattainment area in order to meet mandatory RACT requirements; however, many of the facilities affected by this expansion may already meet the requirements and not incur additional costs.

It should be noted that CTG based rules similar to Ohio's rules can also be found in Ohio's neighbor states and in any state containing a moderate ozone non-attainment area. Facilities wishing to locate in these types of areas will need to meet these requirements in all states.

3. **Is this rule the result of a federal government requirement? Yes**
 - A. **If yes, does this rule do more than the federal government requires? No**
 - B. **If yes, what are the costs, in dollars, to the local government for the regulation that exceeds the federal government requirement?**

Not Applicable

4. **Please provide an estimated cost of compliance for the proposed rule if it has an impact on the following:**
 - A. **Personnel Costs**

See above.
 - B. **New Equipment or Other Capital Costs**

See above.
 - C. **Operating Costs**

See above.
 - D. **Any Indirect Central Service Costs**

See above.
 - E. **Other Costs**

See above.

5. **Please explain how the local government(s) will be able to pay for the increased costs associated with the rule.**

Ohio EPA acknowledges that there will be an increase in costs associated with the expansion of the requirements in the Cincinnati ozone nonattainment area in order

to meet mandatory RACT requirements; however, many of the facilities affected by this expansion may already meet the requirements and not incur additional costs. Facilities that are affected will need to adjust their operational and maintenance budgets accordingly. These budgets are typically financed through a general fund.

6. What will be the impact on economic development, if any, as the result of this rule?

These rules are being promulgated to implement federal requirements for the application of reasonably available control technology to source categories of VOC in moderate ozone non-attainment areas. Rules governing VOC for these source types are in effect in many places around the country, and are not unique to the area covered by this rule. Therefore, any potential economic impact in the affected area would be minimal.

Reducing emissions benefits the affected area by providing a cost savings and economic benefit to stakeholders through reduced pollution. Not only does reducing pollution provide for better enjoyment of the states resources through cleaner air but also reduces property damage caused by pollution, reduces illnesses and reduces healthcare costs. The cost benefits, although difficult to quantify, are significant and may exceed the cost incurred by regulated entities required to comply with VOC RACT rules.

Rule Summary and Fiscal Analysis

Part C - Environmental Rule Questions

Pursuant to Am. Sub. H.B. 106 of the 121st General Assembly, prior to adopting a rule or an amendment to a rule dealing with environmental protection, or containing a component dealing with environmental protection, a state agency shall:

- (1) Consult with organizations that represent political subdivisions, environmental interests, business interests, and other persons affected by the proposed rule or amendment.
- (2) Consider documentation relevant to the need for, the environmental benefits or consequences of, other benefits of, and the technological feasibility of the proposed rule or rule amendment.
- (3) Specifically identify whether the proposed rule or rule amendment is being adopted or amended to enable the state to obtain or maintain approval to administer and enforce a federal environmental law or to participate in a federal environmental program, whether the proposed rule or rule amendment is more stringent than its federal counterpart, and, if the proposed rule or rule amendment is more stringent, the rationale for not incorporating its federal counterpart.
- (4) Include with the proposed rule or rule amendment and rule summary and fiscal analysis required to be filed with the Joint Committee on Agency Rule Review information relevant to the previously listed requirements.

(A) Were organizations that represent political subdivisions, environmental interests, business interests, and other persons affected by the proposed rule or amendment consulted? Yes

Please list each contact.

A draft of these rules was released for a 30-day public comment and review period ending June 18, 2021. The rules were released to Ohio EPA's electronic interested parties list, posted on Ohio EPA's regulations website and shared with interested industry parties. Several comments were received on Ohio EPA's rulemaking effort. Ohio EPA's response to comments document can be provided upon request. A copy of Ohio EPA's interested parties distribution list can be made available upon request.

(B) Was documentation that is relevant to the need for, the environmental benefits or consequences of, other benefits of, and the technological feasibility of the proposed rule or amendment considered? Yes

Please list the information provided and attach a copy of each piece of documentation to this form. (A SUMMARY OR INDEX MAY BE ATTACHED IN LIEU OF THE ACTUAL DOCUMENTATION.)

Clean Air Act, USEPA Control Technique Guidance Documents, LSC Style and Formatting Manual, and comments from interested parties.

- (C) **Is the proposed rule or rule amendment being adopted or amended to enable the state to obtain or maintain approval to administer and enforce a federal environmental law or to participate in a federal environmental program? Yes**

Is the proposed rule or rule amendment more stringent than its federal counterpart?
No Not Applicable

- (D) **If this is a rule amendment that is being adopted under a state statute that establishes standards with which the amendment is to comply, is the proposed rule amendment more stringent than the rule that it is proposing to amend? No**

Rule Summary and Fiscal Analysis

Part A - General Questions

Rule Number: 3745-21-23

Rule Type: Amendment

Rule Title/Tagline: Control of volatile organic compound emissions from industrial solvent cleaning operations.

Agency Name: Ohio Environmental Protection Agency

Division:

Address: 50 West Town Street, Suite 700 PO Box 1049 Columbus OH 43216-1049

Contact: Holly Kaloz **Phone:** 614-644-2760

Email: holly.kaloz@epa.ohio.gov

I. Rule Summary

1. **Is this a five year rule review?** Yes
 - A. **What is the rule's five year review date?** 11/29/2021
2. **Is this rule the result of recent legislation?** No
3. **What statute is this rule being promulgated under?** 119.03
4. **What statute(s) grant rule writing authority?** 3704.03(E)
5. **What statute(s) does the rule implement or amplify?** 3704.03(A), 3704.03(E)
6. **What are the reasons for proposing the rule?**

This rule is being filed to fulfill the requirements of ORC 106.03 (5-yr review) and to adopt mandatory Reasonably Available Control Technology (RACT) requirements for the Cincinnati and Cleveland 2015 ozone nonattainment areas.

7. **Summarize the rule's content, and if this is an amended rule, also summarize the rule's changes.**

This rule identifies VOC emission and control requirements for industrial solvent cleaning operations. This rule is being amended to expand CTG requirements to the Cincinnati nonattainment area.

- 8. Does the rule incorporate material by reference? Yes**
- 9. If the rule incorporates material by reference and the agency claims the material is exempt pursuant to R.C. 121.75, please explain the basis for the exemption and how an individual can find the referenced material.**

This rule contains references to the Ohio Administrative Code (OAC). While copies of these rules and statutes are generally available to the public through libraries and on-line sources, including the Ohio EPA website, ORC 121.76 (A) exempts such references from the provisions of ORC 121.71 through 121.75.

This rule also contains references to the Code of Federal Regulations (CFR). These rules are generally available through libraries, Ohio EPA and U.S. EPA websites. CFR references have also been dated to reference the specific version of the rules. ORC 121.75 (D) exempts such references from the requirements of ORC 121.71 through 121.74.

The rule also contains references to analytical test methods used to determine parameters for materials subject to this rule or other materials utilized by regulators and impacted parties to determine or achieve compliance with these rules. These test methods and materials are commonly known and utilized by laboratories performing this type of analytical work. Copies of these test methods are available in libraries and the websites of the method's supporting organization (ASTM, ANSI, NFPA, NACE, etc.).

Referenced materials are cited, dated and availability noted in paragraph (JJ) of rule 3745-21-01 of the Administrative Code.

- 10. If revising or re-filing the rule, please indicate the changes made in the revised or re-filed version of the rule.**

Ohio EPA's website is converting to the State of Ohio IOP platform during the comment period for this rule-making, therefore the link to the rules in the public notice would no longer work. Ohio EPA is revise filing to change the public notice to the updated web location.

II. Fiscal Analysis

11. Please estimate the increase / decrease in the agency's revenues or expenditures in the current biennium due to this rule.

This will have no impact on revenues or expenditures.

0.00

Not Applicable

12. What are the estimated costs of compliance for all persons and/or organizations directly affected by the rule?

OAC Chapter 3745-21 has been in the OAC since 1972. The rules have evolved over the years to address requirements in the Clean Air Act to develop regulations as part of an effort to achieve the NAAQS for CO and ozone within the state. These rules and additional technical support were submitted to U.S. EPA for review and approval as part of the SIP.

This Chapter has been modified over the years to incorporate requirements for categories of sources for which U.S. EPA has indicated that RACT should apply. In general, the levels of control that are available have been evaluated and presented in a series of CTGs issued by U.S. EPA. There are also rules based on information provided by U.S. EPA for other sources which were identified as non-CTG RACT.

Given the many and varied types of processes that are regulated under OAC chapter 3745-21, it is difficult to give an exact cost of compliance with the rules in this chapter in a limited space. The cost of compliance with these rules can range from zero cost for a control technology such as a work practice or raw material change, to a few million dollars for the installation and operation of a mechanical control device. As part of the permitting process, facilities can perform a RACT analysis which allows them to determine, based on all technologies available, the best and most cost-effective control strategy for their facility.

This rule has been in effect for several years. Most of the costs associated with compliance with the existing requirements of this rule have been addressed in previous rulemakings and have been well established in the industry. There may be some additional cost of compliance related to the expansion of the requirements in the Cincinnati ozone nonattainment area in order to meet mandatory RACT requirements; however, many of the facilities affected by this expansion may already meet the requirements and not incur additional costs.

It should be noted that CTG based rules similar to Ohio's rules can also be found in Ohio's neighbor states and in any state containing a moderate ozone non-attainment area. Facilities wishing to locate in these types of areas will need to meet these requirements in all states.

13. **Does the rule increase local government costs? (If yes, you must complete an RSFA Part B). Yes**
14. **Does the rule regulate environmental protection? (If yes, you must complete an RSFA Part C). Yes**
15. **If the rule imposes a regulation fee, explain how the fee directly relates to your agency's cost in regulating the individual or business.**

Not Applicable

III. Common Sense Initiative (CSI) Questions

16. **Was this rule filed with the Common Sense Initiative Office? Yes**
17. **Does this rule have an adverse impact on business? Yes**

- A. **Does this rule require a license, permit, or any other prior authorization to engage in or operate a line of business? Yes**

An affected facility is required to submit a notification to the Ohio EPA district office or local air agency in writing that states that the facility is subject to this rule. A new permit is required if the facility does not already possess a complying permit.

- B. **Does this rule impose a criminal penalty, a civil penalty, or another sanction, or create a cause of action, for failure to comply with its terms? No**
- C. **Does this rule require specific expenditures or the report of information as a condition of compliance? Yes**

The rule requires periodic submission of reports that typically include deviations from requirements and exceedances of emissions limits. These costs are discussed in the fiscal analysis for this rule.

- D. **Is it likely that the rule will directly reduce the revenue or increase the expenses of the lines of business of which it will apply or applies? No**

IV. Regulatory Restrictions (This section only applies to agencies indicated in R.C. 121.95 (A))

18. Are you adding a new or removing an existing regulatory restriction as defined in R.C. 121.95? Yes

A. How many new regulatory restrictions do you propose adding? 4

New restriction: OAC 3745-21-23(I)(1): The owner or operator of a facility that is subject to this rule, is located in located in Ashtabula, Cuyahoga, Geauga, Lake, Lorain, Medina, Portage, or Summit county, and has an initial startup of solvent cleaning operations before April 2, 2009 shall notify the appropriate Ohio EPA district office or local air agency in writing that the solvent cleaning operation is subject to this rule not later than June 1, 2009, providing the information specified in paragraph (I)(5) of this rule.

Removed restriction 1: OAC 3745-21-07(M)(3)(b): The owner or operator of any article, machine, equipment, or other contrivance meeting paragraph (M)(3)(a) of this rule, and not specified in paragraph (M)(1) of this rule, shall notify Ohio EPA of the need to be specified in paragraph (M)(1) of this rule. Such notification shall be submitted by May 18, 2008. (Changed to: The owner or operator of any article, machine, equipment, or other contrivance meeting paragraph (M)(3)(a) of this rule, and not specified in paragraph (M)(1) of this rule, shall notify Ohio EPA by May 18, 2008 of the need to be specified in paragraph (M)(1) of this rule.)

Removed restriction 2: OAC 3745-21-07(M)(3)(d): The following specific articles, machines, equipment or other contrivances shall not be subject to paragraphs (M)(3)(a) and (M)(3) (b) of this rule: (changed "shall not be subject to" to "are exempt from")

New restriction: OAC 3745-21-23(I)(2): The owner or operator of a facility that is subject to this rule, is located in Ashtabula, Cuyahoga, Geauga, Lake, Lorain, Medina, Portage, or Summit county, and has an initial startup of solvent cleaning operations on or after April 2, 2009 shall notify the appropriate Ohio EPA district office or local air agency in writing that the solvent cleaning operation is subject to this rule not later than either the date of initial startup of the solvent cleaning operation or June 1, 2009 (whichever is later), providing the information specified in paragraph (I)(5) of this rule.

Removed restriction 1: OAC 3745-21-07(M)(5)(a): Paragraph (M)(2) of this rule shall not apply to ~~the~~ (changed "shall" to "does")

Removed restriction 2: OAC 3745-21-07(M)(5)(b): Paragraphs (M)(2), (M)(3)(a) and (M)(4) of this rule shall not apply toÃ¢Ä (changed "shall" to "do")

New restriction: OAC 3745-21-23(I)(3): The owner or operator of a facility that is subject to this rule, is located in Butler, Clermont, Hamilton or Warren county, and has an initial startup of solvent cleaning operations before the effective date of this rule shall notify the appropriate Ohio EPA district office or local air agency in writing that the solvent cleaning operation is subject to this rule not later than sixty days after the effective date of this rule, providing the information specified in paragraph (I)(5) of this rule.

Removed restriction 1: OAC 3745-21-07(M)(5)(c): Paragraph (M)(2) of this rule shall not apply toÃ¢Ä (changed "shall" to "does")

Removed restriction 2: OAC 3745-21-07(M)(5)(d): Paragraphs (M)(1), (M)(2), (M)(3)(a) and (M)(4) of this rule shall not apply toÃ¢Ä (changed "shall" to "do")

New restriction: OAC 3745-21-23(I)(4): The owner or operator of a facility that is subject to this rule, is located in Butler, Clermont, Hamilton or Warren county, and has an initial startup of solvent cleaning operations on or after the effective date of this rule shall notify the appropriate Ohio EPA district office or local air agency in writing that the solvent cleaning operation is subject to this rule not later than either the date of initial startup of the solvent cleaning operation or sixty days after the effective date of this rule (whichever is later), providing the information specified in paragraph (I)(5) of this rule.

Removed restriction 1: OAC 3745-21-07(M)(5)(e): Paragraphs (M)(2), (M)(3)(d), (M)(3)(e), (M)(3)(f), (M)(3)(g), (M)(3)(h) and (M)(4) of this rule shall not apply toÃ¢Ä (changed "shall" to "do")

Removed restriction 2: OAC 3745-21-07(M)(5)(e)(i): The equivalent best available technology requirement shall be consistent with (changed "shall be" to "is")

B. How many existing regulatory restrictions do you propose removing? 5

Removed restriction: OAC 3745-21-23(I)(5): The owner or operator of a facility that is subject to this rule and that has a solvent cleaning operation with an

initial startup date before April 2, 2009 shall notify the Ohio EPA district office or local air agency in writing that the solvent cleaning operation is subject to this rule. (moved)

Removed restriction: OAC 3745-21-23(l)(5): The notification, which shall be submitted not later than June 1, 2009 (or within sixty days after the solvent cleaning operation becomes subject to this rule), (moved)

Removed restriction: OAC 3745-21-23(l)(2): The owner or operator of an offset lithographic or letterpress printing facility that is subject to this rule and that has an offset lithographic or letterpress printing press with an initial startup date on or after April 2, 2009 of this rule shall notify the Ohio EPA district office or local air agency in writing that the offset lithographic or letterpress printing press is subject to this rule. (moved)

Removed restriction: OAC 3745-21-23(l)(2): The notification, which shall be submitted not later than either the date of initial startup of the solvent cleaning operation or June 1, 2009, whichever is later (moved)

Removed restriction: OAC 3745-21-23(l)(2): shall provide the information listed under paragraph (l)(1) of this rule. (moved)

Rule Summary and Fiscal Analysis

Part B - Local Governments Questions

1. Does the rule increase costs for:

A. Public School Districts	No
B. County Government	Yes
C. Township Government	Yes
D. City and Village Governments	Yes

2. Please estimate the total cost, in dollars, of compliance with the rule for the affected local government(s). If you cannot give a dollar cost, explain how the local government is financially impacted.

OAC Chapter 3745-21 has been in the OAC since 1972. The rules have evolved over the years to address requirements in the Clean Air Act to develop regulations as part of an effort to achieve the NAAQS for CO and ozone within the state. These rules and additional technical support were submitted to U.S. EPA for review and approval as part of the SIP.

This Chapter has been modified over the years to incorporate requirements for categories of sources for which U.S. EPA has indicated that RACT should apply. In general, the levels of control that are available have been evaluated and presented in a series of CTGs issued by U.S. EPA. There are also rules based on information provided by U.S. EPA for other sources which were identified as non-CTG RACT.

Given the many and varied types of processes that are regulated under OAC chapter 3745-21, it is difficult to give an exact cost of compliance with the rules in this chapter in a limited space. The cost of compliance with these rules can range from zero cost for a control technology such as a work practice or raw material change, to a few million dollars for the installation and operation of a mechanical control device. As part of the permitting process, facilities can perform a RACT analysis which allows them to determine, based on all technologies available, the best and most cost-effective control strategy for their facility.

This rule has been in effect for several years. Most of the costs associated with compliance with the existing requirements of this rule have been addressed in previous rulemakings and have been well established in the industry. There may be some additional cost of compliance related to the expansion of the requirements in the

Cincinnati ozone nonattainment area in order to meet mandatory RACT requirements; however, many of the facilities affected by this expansion may already meet the requirements and not incur additional costs.

It should be noted that CTG based rules similar to Ohio's rules can also be found in Ohio's neighbor states and in any state containing a moderate ozone non-attainment area. Facilities wishing to locate in these types of areas will need to meet these requirements in all states.

3. **Is this rule the result of a federal government requirement? Yes**
 - A. **If yes, does this rule do more than the federal government requires? No**
 - B. **If yes, what are the costs, in dollars, to the local government for the regulation that exceeds the federal government requirement?**

Not Applicable
4. **Please provide an estimated cost of compliance for the proposed rule if it has an impact on the following:**
 - A. **Personnel Costs**

See above.
 - B. **New Equipment or Other Capital Costs**

See above.
 - C. **Operating Costs**

See above.
 - D. **Any Indirect Central Service Costs**

See above.
 - E. **Other Costs**

See above.
5. **Please explain how the local government(s) will be able to pay for the increased costs associated with the rule.**

Ohio EPA acknowledges that there will be an increase in costs associated with the expansion of the requirements in the Cincinnati ozone nonattainment area in order

to meet mandatory RACT requirements; however, many of the facilities affected by this expansion may already meet the requirements and not incur additional costs. Facilities that are affected will need to adjust their operational and maintenance budgets accordingly. These budgets are typically financed through a general fund.

6. What will be the impact on economic development, if any, as the result of this rule?

These rules are being promulgated to implement federal requirements for the application of reasonably available control technology to source categories of VOC in moderate ozone non-attainment areas. Rules governing VOC for these source types are in effect in many places around the country, and are not unique to the area covered by this rule. Therefore, any potential economic impact in the affected area would be minimal.

Reducing emissions benefits the affected area by providing a cost savings and economic benefit to stakeholders through reduced pollution. Not only does reducing pollution provide for better enjoyment of the states resources through cleaner air but also reduces property damage caused by pollution, reduces illnesses and reduces healthcare costs. The cost benefits, although difficult to quantify, are significant and may exceed the cost incurred by regulated entities required to comply with VOC RACT rules.

Rule Summary and Fiscal Analysis

Part C - Environmental Rule Questions

Pursuant to Am. Sub. H.B. 106 of the 121st General Assembly, prior to adopting a rule or an amendment to a rule dealing with environmental protection, or containing a component dealing with environmental protection, a state agency shall:

- (1) Consult with organizations that represent political subdivisions, environmental interests, business interests, and other persons affected by the proposed rule or amendment.
- (2) Consider documentation relevant to the need for, the environmental benefits or consequences of, other benefits of, and the technological feasibility of the proposed rule or rule amendment.
- (3) Specifically identify whether the proposed rule or rule amendment is being adopted or amended to enable the state to obtain or maintain approval to administer and enforce a federal environmental law or to participate in a federal environmental program, whether the proposed rule or rule amendment is more stringent than its federal counterpart, and, if the proposed rule or rule amendment is more stringent, the rationale for not incorporating its federal counterpart.
- (4) Include with the proposed rule or rule amendment and rule summary and fiscal analysis required to be filed with the Joint Committee on Agency Rule Review information relevant to the previously listed requirements.

(A) Were organizations that represent political subdivisions, environmental interests, business interests, and other persons affected by the proposed rule or amendment consulted? Yes

Please list each contact.

A draft of these rules was released for a 30-day public comment and review period ending June 18, 2021. The rules were released to Ohio EPA's electronic interested parties list, posted on Ohio EPA's regulations website and shared with interested industry parties. Several comments were received on Ohio EPA's rulemaking effort. Ohio EPA's response to comments document can be provided upon request. A copy of Ohio EPA's interested parties distribution list can be made available upon request.

(B) Was documentation that is relevant to the need for, the environmental benefits or consequences of, other benefits of, and the technological feasibility of the proposed rule or amendment considered? Yes

Please list the information provided and attach a copy of each piece of documentation to this form. (A SUMMARY OR INDEX MAY BE ATTACHED IN LIEU OF THE ACTUAL DOCUMENTATION.)

Clean Air Act, USEPA Control Technique Guidance Documents, LSC Style and Formatting Manual, and comments from interested parties.

- (C) **Is the proposed rule or rule amendment being adopted or amended to enable the state to obtain or maintain approval to administer and enforce a federal environmental law or to participate in a federal environmental program? Yes**

Is the proposed rule or rule amendment more stringent than its federal counterpart?
No Not Applicable

- (D) **If this is a rule amendment that is being adopted under a state statute that establishes standards with which the amendment is to comply, is the proposed rule amendment more stringent than the rule that it is proposing to amend? No**

Rule Summary and Fiscal Analysis

Part A - General Questions

Rule Number: 3745-21-24

Rule Type: Amendment

Rule Title/Tagline: Flat wood paneling coatings.

Agency Name: Ohio Environmental Protection Agency

Division:

Address: 50 West Town Street, Suite 700 PO Box 1049 Columbus OH 43216-1049

Contact: Holly Kaloz **Phone:** 614-644-2760

Email: holly.kaloz@epa.ohio.gov

I. Rule Summary

1. **Is this a five year rule review?** Yes
 - A. **What is the rule's five year review date?** 11/29/2021
2. **Is this rule the result of recent legislation?** No
3. **What statute is this rule being promulgated under?** 119.03
4. **What statute(s) grant rule writing authority?** 3704.03(E)
5. **What statute(s) does the rule implement or amplify?** 3704.03(A), 3704.03(E)
6. **What are the reasons for proposing the rule?**

This rule is being filed to fulfill the requirements of ORC 106.03 (5-yr review) and to adopt mandatory Reasonably Available Control Technology (RACT) requirements for the Cincinnati and Cleveland 2015 ozone nonattainment areas.

7. **Summarize the rule's content, and if this is an amended rule, also summarize the rule's changes.**

This rule establishes emission control requirements for sources of VOC's in the flat wood paneling coating industry. This rule is being amended to expand CTG requirements to the Cincinnati nonattainment area.

8. **Does the rule incorporate material by reference? Yes**
9. **If the rule incorporates material by reference and the agency claims the material is exempt pursuant to R.C. 121.75, please explain the basis for the exemption and how an individual can find the referenced material.**

This rule contains references to the Ohio Administrative Code (OAC). While copies of these rules and statutes are generally available to the public through libraries and on-line sources, including the Ohio EPA website, ORC 121.76 (A) exempts such references from the provisions of ORC 121.71 through 121.75.

This rule also contains references to the Code of Federal Regulations (CFR). These rules are generally available through libraries, Ohio EPA and U.S. EPA websites. CFR references have also been dated to reference the specific version of the rules. ORC 121.75 (D) exempts such references from the requirements of ORC 121.71 through 121.74.

The rule also contains references to analytical test methods used to determine parameters for materials subject to this rule or other materials utilized by regulators and impacted parties to determine or achieve compliance with these rules. These test methods and materials are commonly known and utilized by laboratories performing this type of analytical work. Copies of these test methods are available in libraries and the websites of the method's supporting organization (ASTM, ANSI, NFPA, NACE, etc.).

Referenced materials are cited, dated and availability noted in paragraph (JJ) of rule 3745-21-01 of the Administrative Code.

10. **If revising or re-filing the rule, please indicate the changes made in the revised or re-filed version of the rule.**

Ohio EPA's website is converting to the State of Ohio IOP platform during the comment period for this rule-making, therefore the link to the rules in the public notice would no longer work. Ohio EPA is revise filing to change the public notice to the updated web location.

II. Fiscal Analysis

11. **Please estimate the increase / decrease in the agency's revenues or expenditures in the current biennium due to this rule.**

This will have no impact on revenues or expenditures.

0.00

Not Applicable

12. What are the estimated costs of compliance for all persons and/or organizations directly affected by the rule?

OAC Chapter 3745-21 has been in the OAC since 1972. The rules have evolved over the years to address requirements in the Clean Air Act to develop regulations as part of an effort to achieve the NAAQS for CO and ozone within the state. These rules and additional technical support were submitted to U.S. EPA for review and approval as part of the SIP.

This Chapter has been modified over the years to incorporate requirements for categories of sources for which U.S. EPA has indicated that RACT should apply. In general, the levels of control that are available have been evaluated and presented in a series of CTGs issued by U.S. EPA. There are also rules based on information provided by U.S. EPA for other sources which were identified as non-CTG RACT.

Given the many and varied types of processes that are regulated under OAC chapter 3745-21, it is difficult to give an exact cost of compliance with the rules in this chapter in a limited space. The cost of compliance with these rules can range from zero cost for a control technology such as a work practice or raw material change, to a few million dollars for the installation and operation of a mechanical control device. As part of the permitting process, facilities can perform a RACT analysis which allows them to determine, based on all technologies available, the best and most cost-effective control strategy for their facility.

This rule has been in effect for several years. Most of the costs associated with compliance with the existing requirements of this rule have been addressed in previous rulemakings and have been well established in the industry. There may be some additional cost of compliance related to the expansion of the requirements in the Cincinnati ozone nonattainment area in order to meet mandatory RACT requirements; however, many of the facilities affected by this expansion may already meet the requirements and not incur additional costs.

It should be noted that CTG based rules similar to Ohio's rules can also be found in Ohio's neighbor states and in any state containing a moderate ozone non-attainment area. Facilities wishing to locate in these types of areas will need to meet these requirements in all states.

13. Does the rule increase local government costs? (If yes, you must complete an RSFA Part B). Yes

14. Does the rule regulate environmental protection? (If yes, you must complete an RSFA Part C). Yes
15. If the rule imposes a regulation fee, explain how the fee directly relates to your agency's cost in regulating the individual or business.

Not Applicable

III. Common Sense Initiative (CSI) Questions

16. Was this rule filed with the Common Sense Initiative Office? Yes
17. Does this rule have an adverse impact on business? Yes
 - A. Does this rule require a license, permit, or any other prior authorization to engage in or operate a line of business? Yes

An affected facility is required to submit a notification to the Ohio EPA district office or local air agency in writing that states that the facility is subject to this rule. A new permit is required if the facility does not already possess a complying permit.

- B. Does this rule impose a criminal penalty, a civil penalty, or another sanction, or create a cause of action, for failure to comply with its terms? No
- C. Does this rule require specific expenditures or the report of information as a condition of compliance? Yes

The rule requires periodic submission of reports that typically include deviations from requirements and exceedances of emissions limits. These costs are discussed in the fiscal analysis for this rule.

- D. Is it likely that the rule will directly reduce the revenue or increase the expenses of the lines of business of which it will apply or applies? No

IV. Regulatory Restrictions (This section only applies to agencies indicated in R.C. 121.95 (A))

18. Are you adding a new or removing an existing regulatory restriction as defined in R.C. 121.95? Yes

A. How many new regulatory restrictions do you propose adding? 2

New restriction: OAC 3745-21-24(J)(3): The owner or operator of a facility that is subject to this rule, is located in Butler, Clermont, Hamilton or Warren county, and has an initial startup of a flat wood paneling coating line before the effective date of this rule shall notify the appropriate Ohio EPA district office or local air agency in writing that the flat wood paneling coating line is subject to this rule not later than sixty days after the effective date of this rule, providing the information specified in paragraph (L)(5) of this rule.

Removed restriction 1: OAC 3745-21-07(M)(5)(e)(i): ...for purposes of this paragraph, shall provide... (removed shall)

Removed restriction 2: OAC 3745-21-07(M)(5)(e)(i): ...the best available technology determination must comply with Section 193 of the Clean Air Act... (changed "must comply" to "complies")

New restriction: OAC 3745-21-24(J)(4): The owner or operator of a facility that is subject to this rule, is located in Butler, Clermont, Hamilton or Warren county, and has an initial startup of a flat wood paneling coating line on or after the effective date of this rule shall notify the appropriate Ohio EPA district office or local air agency in writing that the flat wood paneling coating line is subject to this rule not later than either the date of initial startup of the flat wood paneling coating line or sixty days after the effective date of this rule (whichever is later), providing the information specified in paragraph (L)(5) of this rule.

Removed restriction 1: OAC 3745-21-07(M)(5)(e)(iii): The permit-to-install shall contain terms and conditions... (changed "shall contain" to "contains")

Removed restriction 2: OAC 3745-21-07(M)(5)(e)(iii): The permit-toinstall shall be issued by the Ohio EPA (changed "shall be" to "and that is")

B. How many existing regulatory restrictions do you propose removing? 0

Rule Summary and Fiscal Analysis

Part B - Local Governments Questions

1. Does the rule increase costs for:

A. Public School Districts	No
B. County Government	Yes
C. Township Government	Yes
D. City and Village Governments	Yes

2. Please estimate the total cost, in dollars, of compliance with the rule for the affected local government(s). If you cannot give a dollar cost, explain how the local government is financially impacted.

OAC Chapter 3745-21 has been in the OAC since 1972. The rules have evolved over the years to address requirements in the Clean Air Act to develop regulations as part of an effort to achieve the NAAQS for CO and ozone within the state. These rules and additional technical support were submitted to U.S. EPA for review and approval as part of the SIP.

This Chapter has been modified over the years to incorporate requirements for categories of sources for which U.S. EPA has indicated that RACT should apply. In general, the levels of control that are available have been evaluated and presented in a series of CTGs issued by U.S. EPA. There are also rules based on information provided by U.S. EPA for other sources which were identified as non-CTG RACT.

Given the many and varied types of processes that are regulated under OAC chapter 3745-21, it is difficult to give an exact cost of compliance with the rules in this chapter in a limited space. The cost of compliance with these rules can range from zero cost for a control technology such as a work practice or raw material change, to a few million dollars for the installation and operation of a mechanical control device. As part of the permitting process, facilities can perform a RACT analysis which allows them to determine, based on all technologies available, the best and most cost-effective control strategy for their facility.

This rule has been in effect for several years. Most of the costs associated with compliance with the existing requirements of this rule have been addressed in previous rulemakings and have been well established in the industry. There may be some additional cost of compliance related to the expansion of the requirements in the

Cincinnati ozone nonattainment area in order to meet mandatory RACT requirements; however, many of the facilities affected by this expansion may already meet the requirements and not incur additional costs.

It should be noted that CTG based rules similar to Ohio's rules can also be found in Ohio's neighbor states and in any state containing a moderate ozone non-attainment area. Facilities wishing to locate in these types of areas will need to meet these requirements in all states.

3. **Is this rule the result of a federal government requirement? Yes**
 - A. **If yes, does this rule do more than the federal government requires? No**
 - B. **If yes, what are the costs, in dollars, to the local government for the regulation that exceeds the federal government requirement?**

Not Applicable

4. **Please provide an estimated cost of compliance for the proposed rule if it has an impact on the following:**
 - A. **Personnel Costs**

See above.
 - B. **New Equipment or Other Capital Costs**

See above.
 - C. **Operating Costs**

See above.
 - D. **Any Indirect Central Service Costs**

See above.
 - E. **Other Costs**

See above.

5. **Please explain how the local government(s) will be able to pay for the increased costs associated with the rule.**

Ohio EPA acknowledges that there will be an increase in costs associated with the expansion of the requirements in the Cincinnati ozone nonattainment area in order

to meet mandatory RACT requirements; however, many of the facilities affected by this expansion may already meet the requirements and not incur additional costs. Facilities that are affected will need to adjust their operational and maintenance budgets accordingly. These budgets are typically financed through a general fund.

6. What will be the impact on economic development, if any, as the result of this rule?

These rules are being promulgated to implement federal requirements for the application of reasonably available control technology to source categories of VOC in moderate ozone non-attainment areas. Rules governing VOC for these source types are in effect in many places around the country, and are not unique to the area covered by this rule. Therefore, any potential economic impact in the affected area would be minimal.

Reducing emissions benefits the affected area by providing a cost savings and economic benefit to stakeholders through reduced pollution. Not only does reducing pollution provide for better enjoyment of the states resources through cleaner air but also reduces property damage caused by pollution, reduces illnesses and reduces healthcare costs. The cost benefits, although difficult to quantify, are significant and may exceed the cost incurred by regulated entities required to comply with VOC RACT rules.

Rule Summary and Fiscal Analysis

Part C - Environmental Rule Questions

Pursuant to Am. Sub. H.B. 106 of the 121st General Assembly, prior to adopting a rule or an amendment to a rule dealing with environmental protection, or containing a component dealing with environmental protection, a state agency shall:

- (1) Consult with organizations that represent political subdivisions, environmental interests, business interests, and other persons affected by the proposed rule or amendment.
- (2) Consider documentation relevant to the need for, the environmental benefits or consequences of, other benefits of, and the technological feasibility of the proposed rule or rule amendment.
- (3) Specifically identify whether the proposed rule or rule amendment is being adopted or amended to enable the state to obtain or maintain approval to administer and enforce a federal environmental law or to participate in a federal environmental program, whether the proposed rule or rule amendment is more stringent than its federal counterpart, and, if the proposed rule or rule amendment is more stringent, the rationale for not incorporating its federal counterpart.
- (4) Include with the proposed rule or rule amendment and rule summary and fiscal analysis required to be filed with the Joint Committee on Agency Rule Review information relevant to the previously listed requirements.

(A) Were organizations that represent political subdivisions, environmental interests, business interests, and other persons affected by the proposed rule or amendment consulted? Yes

Please list each contact.

A draft of these rules was released for a 30-day public comment and review period ending June 18, 2021. The rules were released to Ohio EPA's electronic interested parties list, posted on Ohio EPA's regulations website and shared with interested industry parties. Several comments were received on Ohio EPA's rulemaking effort. Ohio EPA's response to comments document can be provided upon request. A copy of Ohio EPA's interested parties distribution list can be made available upon request.

(B) Was documentation that is relevant to the need for, the environmental benefits or consequences of, other benefits of, and the technological feasibility of the proposed rule or amendment considered? Yes

Please list the information provided and attach a copy of each piece of documentation to this form. (A SUMMARY OR INDEX MAY BE ATTACHED IN LIEU OF THE ACTUAL DOCUMENTATION.)

Clean Air Act, USEPA Control Technique Guidance Documents, LSC Style and Formatting Manual, and comments from interested parties.

- (C) **Is the proposed rule or rule amendment being adopted or amended to enable the state to obtain or maintain approval to administer and enforce a federal environmental law or to participate in a federal environmental program? Yes**

Is the proposed rule or rule amendment more stringent than its federal counterpart?
No Not Applicable

- (D) **If this is a rule amendment that is being adopted under a state statute that establishes standards with which the amendment is to comply, is the proposed rule amendment more stringent than the rule that it is proposing to amend? No**

Rule Summary and Fiscal Analysis

Part A - General Questions

Rule Number: 3745-21-25

Rule Type: Amendment

Rule Title/Tagline: Control of VOC emissions from reinforced plastic composites production operations.

Agency Name: Ohio Environmental Protection Agency

Division:

Address: 50 West Town Street, Suite 700 PO Box 1049 Columbus OH 43216-1049

Contact: Holly Kaloz **Phone:** 614-644-2760

Email: holly.kaloz@epa.ohio.gov

I. Rule Summary

1. **Is this a five year rule review?** Yes
 - A. **What is the rule's five year review date?** 11/29/2021
2. **Is this rule the result of recent legislation?** No
3. **What statute is this rule being promulgated under?** 119.03
4. **What statute(s) grant rule writing authority?** 3704.03(E)
5. **What statute(s) does the rule implement or amplify?** 3704.03(A), 3704.03(E)
6. **What are the reasons for proposing the rule?**

This rule is being filed to fulfill the requirements of ORC 106.03 (5-yr review).

7. **Summarize the rule's content, and if this is an amended rule, also summarize the rule's changes.**

This rule establishes control requirements for sources of VOC emissions from reinforced plastic composites production operations statewide. This rule is being amended to conform to agency and LSC standards.

8. **Does the rule incorporate material by reference?** Yes

9. **If the rule incorporates material by reference and the agency claims the material is exempt pursuant to R.C. 121.75, please explain the basis for the exemption and how an individual can find the referenced material.**

This rule contains references to the Ohio Administrative Code (OAC). While copies of these rules and statutes are generally available to the public through libraries and on-line sources, including the Ohio EPA website, ORC 121.76 (A) exempts such references from the provisions of ORC 121.71 through 121.75.

This rule also contains references to the Code of Federal Regulations (CFR). These rules are generally available through libraries, Ohio EPA and U.S. EPA websites. CFR references have also been dated to reference the specific version of the rules. ORC 121.75 (D) exempts such references from the requirements of ORC 121.71 through 121.74.

This rule also contains references to the United States Code (USC), the Federal Insecticide, Rodenticide, and Fungicide Act, and the Clean Air Act. These rules and Acts are generally available through libraries, Ohio EPA and Government Printing Office's websites. USC references have also been dated to reference the specific version of the rules. ORC 121.75(D) exempts such references from the requirements of ORC 121.71 through 121.74.

The rule also contains references to analytical test methods used to determine parameters for materials subject to this rule or other materials utilized by regulators and impacted parties to determine or achieve compliance with these rules. These test methods and materials are commonly known and utilized by laboratories performing this type of analytical work. Copies of these test methods are available in libraries and the websites of the method's supporting organization (ASTM, ANSI, NFPA, NACE, etc.).

Referenced materials are cited, dated and availability noted in paragraph (JJ) of rule 3745-21-01 of the Administrative Code.

10. **If revising or re-filing the rule, please indicate the changes made in the revised or re-filed version of the rule.**

Ohio EPA's website is converting to the State of Ohio IOP platform during the comment period for this rule-making, therefore the link to the rules in the public notice would no longer work. Ohio EPA is revise filing to change the public notice to the updated web location.

II. Fiscal Analysis

11. Please estimate the increase / decrease in the agency's revenues or expenditures in the current biennium due to this rule.

This will have no impact on revenues or expenditures.

0.00

Not Applicable

12. What are the estimated costs of compliance for all persons and/or organizations directly affected by the rule?

This rule establishes control requirements for sources of VOC emissions from reinforced plastic composites production operations statewide. This rule is based on the MACT rule for reinforced plastic composites production operations (Subpart WWWW of 40 CFR Part 63).

Cost effectiveness analysis for this rule was provided in U.S. EPA's Federal Register, Volume 68, No. 76, page 19382, National Emission Standards for Hazardous Air Pollutants, "Reinforced Plastic Composites Production", dated April 21, 2003. USEPA's costeffectiveness analysis is summarized as follows:

"U.S. EPA estimates the industry-wide annual costs of the final rule are \$21.5 million per year for the 435 existing sources and \$7.7 million for the 84 new sources. Annual costs include fixed annual costs, such as reporting, recordkeeping and capital amortization, and variable annual costs such as natural gas. The estimated average cost of the final rule is \$2,800 per ton of VOC emissions reductions for existing sources and \$5,560 per ton of VOC emissions reductions for new sources. Based on a review of facilities in Ohio it appears that there are fewer than 10 facilities in the state of Ohio affected by this rule. "

This rule has been in effect for 12+ years. All costs associated with compliance with the existing requirements of this rule have been well established in the industry. The amendments being made to this rule do not add any additional requirements to affected facilities. As such, there is no additional cost of compliance associated with the amendments being made to this rule.

13. Does the rule increase local government costs? (If yes, you must complete an RSFA Part B). No

14. Does the rule regulate environmental protection? (If yes, you must complete an RSFA Part C). Yes

15. If the rule imposes a regulation fee, explain how the fee directly relates to your agency's cost in regulating the individual or business.

Not Applicable

III. Common Sense Initiative (CSI) Questions

16. Was this rule filed with the Common Sense Initiative Office? Yes

17. Does this rule have an adverse impact on business? Yes

- A. Does this rule require a license, permit, or any other prior authorization to engage in or operate a line of business? Yes

An affected facility is required to submit a notification to the Ohio EPA district office or local air agency in writing that states that the facility is subject to this rule. A new permit is required if the facility does not already possess a complying permit.

- B. Does this rule impose a criminal penalty, a civil penalty, or another sanction, or create a cause of action, for failure to comply with its terms? No

- C. Does this rule require specific expenditures or the report of information as a condition of compliance? Yes

The rule requires periodic submission of reports that typically include deviations from requirements and exceedances of emissions limits. These costs are discussed in the fiscal analysis for this rule.

- D. Is it likely that the rule will directly reduce the revenue or increase the expenses of the lines of business of which it will apply or applies? No

IV. Regulatory Restrictions (This section only applies to agencies indicated in R.C. 121.95 (A))

18. Are you adding a new or removing an existing regulatory restriction as defined in R.C. 121.95? No

- A. How many new regulatory restrictions do you propose adding?

Not Applicable

B. How many existing regulatory restrictions do you propose removing?

Not Applicable

Rule Summary and Fiscal Analysis

Part C - Environmental Rule Questions

Pursuant to Am. Sub. H.B. 106 of the 121st General Assembly, prior to adopting a rule or an amendment to a rule dealing with environmental protection, or containing a component dealing with environmental protection, a state agency shall:

- (1) Consult with organizations that represent political subdivisions, environmental interests, business interests, and other persons affected by the proposed rule or amendment.
- (2) Consider documentation relevant to the need for, the environmental benefits or consequences of, other benefits of, and the technological feasibility of the proposed rule or rule amendment.
- (3) Specifically identify whether the proposed rule or rule amendment is being adopted or amended to enable the state to obtain or maintain approval to administer and enforce a federal environmental law or to participate in a federal environmental program, whether the proposed rule or rule amendment is more stringent than its federal counterpart, and, if the proposed rule or rule amendment is more stringent, the rationale for not incorporating its federal counterpart.
- (4) Include with the proposed rule or rule amendment and rule summary and fiscal analysis required to be filed with the Joint Committee on Agency Rule Review information relevant to the previously listed requirements.

(A) Were organizations that represent political subdivisions, environmental interests, business interests, and other persons affected by the proposed rule or amendment consulted? Yes

Please list each contact.

A draft of these rules was released for a 30-day public comment and review period ending June 18, 2021. The rules were released to Ohio EPA's electronic interested parties list, posted on Ohio EPA's regulations website and shared with interested industry parties. Several comments were received on Ohio EPA's rulemaking effort. Ohio EPA's response to comments document can be provided upon request. A copy of Ohio EPA's interested parties distribution list can be made available upon request.

(B) Was documentation that is relevant to the need for, the environmental benefits or consequences of, other benefits of, and the technological feasibility of the proposed rule or amendment considered? Yes

Please list the information provided and attach a copy of each piece of documentation to this form. (A SUMMARY OR INDEX MAY BE ATTACHED IN LIEU OF THE ACTUAL DOCUMENTATION.)

Clean Air Act, USEPA Control Technique Guidance Documents, LSC Style and Formatting Manual, and comments from interested parties.

- (C) Is the proposed rule or rule amendment being adopted or amended to enable the state to obtain or maintain approval to administer and enforce a federal environmental law or to participate in a federal environmental program? Yes**

Is the proposed rule or rule amendment more stringent than its federal counterpart?
No Not Applicable

- (D) If this is a rule amendment that is being adopted under a state statute that establishes standards with which the amendment is to comply, is the proposed rule amendment more stringent than the rule that it is proposing to amend? No**

Rule Summary and Fiscal Analysis

Part A - General Questions

Rule Number: 3745-21-26

Rule Type: Amendment

Rule Title/Tagline: Surface coating of miscellaneous metal and plastic parts.

Agency Name: Ohio Environmental Protection Agency

Division:

Address: 50 West Town Street, Suite 700 PO Box 1049 Columbus OH 43216-1049

Contact: Holly Kaloz **Phone:** 614-644-2760

Email: holly.kaloz@epa.ohio.gov

I. Rule Summary

1. **Is this a five year rule review?** Yes
 - A. **What is the rule's five year review date?** 11/29/2021
2. **Is this rule the result of recent legislation?** No
3. **What statute is this rule being promulgated under?** 119.03
4. **What statute(s) grant rule writing authority?** 3704.03(E)
5. **What statute(s) does the rule implement or amplify?** 3704.03(A), 3704.03(E)
6. **What are the reasons for proposing the rule?**

This rule is being filed to fulfill the requirements of ORC 106.03 (5-yr review) and to adopt mandatory Reasonably Available Control Technology (RACT) requirements for the Cincinnati and Cleveland 2015 ozone nonattainment areas.

7. **Summarize the rule's content, and if this is an amended rule, also summarize the rule's changes.**

This rule is based on a federal Control Technique Guideline (CTG) and establishes emission reduction requirements for facilities involved in the surface coating of

miscellaneous metal and plastic parts. The rule is being amended to expand CTG requirements to the Cincinnati nonattainment area.

- 8. Does the rule incorporate material by reference? Yes**
- 9. If the rule incorporates material by reference and the agency claims the material is exempt pursuant to R.C. 121.75, please explain the basis for the exemption and how an individual can find the referenced material.**

This rule contains references to the Ohio Administrative Code (OAC). While copies of these rules and statutes are generally available to the public through libraries and on-line sources, including the Ohio EPA website, ORC 121.76 (A) exempts such references from the provisions of ORC 121.71 through 121.75.

- 10. If revising or re-filing the rule, please indicate the changes made in the revised or re-filed version of the rule.**

Ohio EPA's website is converting to the State of Ohio IOP platform during the comment period for this rule-making, therefore the link to the rules in the public notice would no longer work. Ohio EPA is revise filing to change the public notice to the updated web location.

II. Fiscal Analysis

- 11. Please estimate the increase / decrease in the agency's revenues or expenditures in the current biennium due to this rule.**

This will have no impact on revenues or expenditures.

0.00

Not Applicable

- 12. What are the estimated costs of compliance for all persons and/or organizations directly affected by the rule?**

OAC Chapter 3745-21 has been in the OAC since 1972. The rules have evolved over the years to address requirements in the Clean Air Act to develop regulations as part of an effort to achieve the NAAQS for CO and ozone within the state. These rules and additional technical support were submitted to U.S. EPA for review and approval as part of the SIP.

This Chapter has been modified over the years to incorporate requirements for categories of sources for which U.S. EPA has indicated that RACT should apply. In general, the levels of control that are available have been evaluated and presented in a series of CTGs issued by U.S. EPA. There are also rules based on information provided by U.S. EPA for other sources which were identified as non-CTG RACT.

Given the many and varied types of processes that are regulated under OAC chapter 3745-21, it is difficult to give an exact cost of compliance with the rules in this chapter in a limited space. The cost of compliance with these rules can range from zero cost for a control technology such as a work practice or raw material change, to a few million dollars for the installation and operation of a mechanical control device. As part of the permitting process, facilities can perform a RACT analysis which allows them to determine, based on all technologies available, the best and most cost-effective control strategy for their facility.

This rule has been in effect for several years. Most of the costs associated with compliance with the existing requirements of this rule have been addressed in previous rulemakings and have been well established in the industry. There may be some additional cost of compliance related to the expansion of the requirements in the Cincinnati ozone nonattainment area in order to meet mandatory RACT requirements; however, many of the facilities affected by this expansion may already meet the requirements and not incur additional costs.

It should be noted that CTG based rules similar to Ohio's rules can also be found in Ohio's neighbor states and in any state containing a moderate ozone non-attainment area. Facilities wishing to locate in these types of areas will need to meet these requirements in all states.

13. **Does the rule increase local government costs? (If yes, you must complete an RSFA Part B). Yes**
14. **Does the rule regulate environmental protection? (If yes, you must complete an RSFA Part C). Yes**
15. **If the rule imposes a regulation fee, explain how the fee directly relates to your agency's cost in regulating the individual or business.**

Not Applicable

III. Common Sense Initiative (CSI) Questions

16. **Was this rule filed with the Common Sense Initiative Office? Yes**
17. **Does this rule have an adverse impact on business? Yes**

- A. Does this rule require a license, permit, or any other prior authorization to engage in or operate a line of business? Yes**

An affected facility is required to submit a notification to the Ohio EPA district office or local air agency in writing that states that the facility is subject to this rule. A new permit is required if the facility does not already possess a complying permit.

- B. Does this rule impose a criminal penalty, a civil penalty, or another sanction, or create a cause of action, for failure to comply with its terms? No**

- C. Does this rule require specific expenditures or the report of information as a condition of compliance? Yes**

The rule requires periodic submission of reports that typically include deviations from requirements and exceedances of emissions limits. These costs are discussed in the fiscal analysis for this rule.

- D. Is it likely that the rule will directly reduce the revenue or increase the expenses of the lines of business of which it will apply or applies? No**

IV. Regulatory Restrictions (This section only applies to agencies indicated in R.C. 121.95 (A))

- 18. Are you adding a new or removing an existing regulatory restriction as defined in R.C. 121.95? Yes**

- A. How many new regulatory restrictions do you propose adding? 4**

New restriction: OAC 3745-21-26(I)(1): The owner or operator of a coating line that is subject to this rule, is located in located in Ashtabula, Cuyahoga, Geauga, Lake, Lorain, Medina, Portage, or Summit county, and has an initial startup of the coating line before October 15, 2015 shall notify the appropriate Ohio EPA district office or local air agency in writing that the coating line is subject to this rule not later than December 14, 2015 or within sixty days after the coating line becomes subject to this rule, providing the information specified in paragraph (I)(5) of this rule.

Removed restriction 1: OAC 3745-21-07(M)(5)(f): Paragraph (M) of this rule shall not apply toâ (changed "shall" to "does")

Removed restriction 2: OAC 3745-21-07(M)(5)(g): Paragraphs (M)(3)(a), (M)(3)(b), (M)(3)(g) and (M)(4) of this rule shall not apply to (changed "shall" to "do")

New restriction: OAC 3745-21-26(I)(2): The owner or operator of a coating line that is subject to this rule, is located in Ashtabula, Cuyahoga, Geauga, Lake, Lorain, Medina, Portage, or Summit county, and has an initial startup of the coating line on or after October 15, 2015 shall notify the appropriate Ohio EPA district office or local air agency in writing that the coating line is subject to this rule not later than either the date of initial startup of the subject coating line or December 14, 2015 (whichever is later), providing the information specified in paragraph (I)(5) of this rule.

Removed restriction 1: OAC 3745-21-07(M)(5)(h): Paragraph (M)(3)(g) of this rule shall not apply to (changed "shall" to "does")

Removed restriction 2: OAC 3745-21-07(M)(5)(i): Paragraph (M)(2) of this rule shall not apply to (changed "shall" to "does")

New restriction: OAC 3745-21-26(I)(3): The owner or operator of a coating line that is subject to this rule, is located in Butler, Clermont, Hamilton or Warren county, and has an initial startup of the coating line before the effective date of this rule shall notify the appropriate Ohio EPA district office or local air agency in writing that the coating line is subject to this rule not later than sixty days after the effective date of this rule, providing the information specified in paragraph (I)(5) of this rule.

Removed restriction 1: OAC 3745-21-09(B)(3)(c): A copy of such record shall be sent to the director within forty-five days after the exceedance occurs. (deleted sentence; added deadline to previous sentence)

Removed restriction 2: OAC 3745-21-09(B)(3)(e): A copy of such record shall be sent to the director within forty-five days after the exceedance occurs. (deleted sentence; added deadline to previous sentence)

New restriction: OAC 3745-21-26(I)(4): The owner or operator of a coating line that is subject to this rule, is located in Butler, Clermont, Hamilton or Warren county, and has an initial startup of the coating line on or after the effective date of this rule shall notify the appropriate Ohio EPA district office or local air agency in writing that the coating line is subject to this rule not later than either the date of initial startup of the subject coating line or sixty days after

the effective date of this rule (whichever is later), providing the information specified in paragraph (l)(5) of this rule.

Removed restriction 1: OAC 3745-21-09(B)(3)(g): A copy of such record shall be sent to the director within thirty days after the exceedance occurs. (deleted sentence; added deadline to previous sentence)

Removed restriction 2: OAC 3745-21-09(B)(3)(i): A copy of such record shall be sent to the director within forty-five days after the exceedance occurs. (deleted sentence; added deadline to previous sentence)

B. How many existing regulatory restrictions do you propose removing? 5

Removed restriction: OAC 3745-21-26(l)(5): The owner or operator of a coating line that is subject to this rule with an initial startup date before the effective date of this rule shall notify the Ohio EPA district office or local air agency in writing that the coating line is subject to this rule. (moved)

Removed restriction: OAC 3745-21-26(l)(5): The notification, which shall be submitted not later than sixty days after the effective date of this rule or within sixty days after the coating line becomes subject to this rule (moved)

Removed restriction: OAC 3745-21-26(l)(2): The owner or operator of a coating line that is subject to this rule with an initial startup date on or after the effective date of this rule shall notify the Ohio EPA district office or local air agency in writing that the coating line is subject to this rule. (moved)

Removed restriction: OAC 3745-21-26(l)(2): The notification, which shall be submitted not later than either the date of initial startup of the subject coating line, or sixty days after the effective date of this rule (whichever is later) (moved)

Removed restriction: OAC 3745-21-26(l)(2) shall provide the information listed under paragraph (l)(1) of this rule. (moved)

Rule Summary and Fiscal Analysis

Part B - Local Governments Questions

1. Does the rule increase costs for:

A. Public School Districts	No
B. County Government	Yes
C. Township Government	Yes
D. City and Village Governments	Yes

2. Please estimate the total cost, in dollars, of compliance with the rule for the affected local government(s). If you cannot give a dollar cost, explain how the local government is financially impacted.

OAC Chapter 3745-21 has been in the OAC since 1972. The rules have evolved over the years to address requirements in the Clean Air Act to develop regulations as part of an effort to achieve the NAAQS for CO and ozone within the state. These rules and additional technical support were submitted to U.S. EPA for review and approval as part of the SIP.

This Chapter has been modified over the years to incorporate requirements for categories of sources for which U.S. EPA has indicated that RACT should apply. In general, the levels of control that are available have been evaluated and presented in a series of CTGs issued by U.S. EPA. There are also rules based on information provided by U.S. EPA for other sources which were identified as non-CTG RACT.

Given the many and varied types of processes that are regulated under OAC chapter 3745-21, it is difficult to give an exact cost of compliance with the rules in this chapter in a limited space. The cost of compliance with these rules can range from zero cost for a control technology such as a work practice or raw material change, to a few million dollars for the installation and operation of a mechanical control device. As part of the permitting process, facilities can perform a RACT analysis which allows them to determine, based on all technologies available, the best and most cost-effective control strategy for their facility.

This rule has been in effect for several years. Most of the costs associated with compliance with the existing requirements of this rule have been addressed in previous rulemakings and have been well established in the industry. There may be some additional cost of compliance related to the expansion of the requirements in the

Cincinnati ozone nonattainment area in order to meet mandatory RACT requirements; however, many of the facilities affected by this expansion may already meet the requirements and not incur additional costs.

It should be noted that CTG based rules similar to Ohio's rules can also be found in Ohio's neighbor states and in any state containing a moderate ozone non-attainment area. Facilities wishing to locate in these types of areas will need to meet these requirements in all states.

3. **Is this rule the result of a federal government requirement? Yes**
 - A. **If yes, does this rule do more than the federal government requires? No**
 - B. **If yes, what are the costs, in dollars, to the local government for the regulation that exceeds the federal government requirement?**

Not Applicable
4. **Please provide an estimated cost of compliance for the proposed rule if it has an impact on the following:**
 - A. **Personnel Costs**

See above.
 - B. **New Equipment or Other Capital Costs**

See above.
 - C. **Operating Costs**

See above.
 - D. **Any Indirect Central Service Costs**

See above.
 - E. **Other Costs**

See above.
5. **Please explain how the local government(s) will be able to pay for the increased costs associated with the rule.**

Ohio EPA acknowledges that there will be an increase in costs associated with the expansion of the requirements in the Cincinnati ozone nonattainment area in order

to meet mandatory RACT requirements; however, many of the facilities affected by this expansion may already meet the requirements and not incur additional costs. Facilities that are affected will need to adjust their operational and maintenance budgets accordingly. These budgets are typically financed through a general fund.

6. What will be the impact on economic development, if any, as the result of this rule?

These rules are being promulgated to implement federal requirements for the application of reasonably available control technology to source categories of VOC in moderate ozone non-attainment areas. Rules governing VOC for these source types are in effect in many places around the country, and are not unique to the area covered by this rule. Therefore, any potential economic impact in the affected area would be minimal.

Reducing emissions benefits the affected area by providing a cost savings and economic benefit to stakeholders through reduced pollution. Not only does reducing pollution provide for better enjoyment of the states resources through cleaner air but also reduces property damage caused by pollution, reduces illnesses and reduces healthcare costs. The cost benefits, although difficult to quantify, are significant and may exceed the cost incurred by regulated entities required to comply with VOC RACT rules.

Rule Summary and Fiscal Analysis

Part C - Environmental Rule Questions

Pursuant to Am. Sub. H.B. 106 of the 121st General Assembly, prior to adopting a rule or an amendment to a rule dealing with environmental protection, or containing a component dealing with environmental protection, a state agency shall:

- (1) Consult with organizations that represent political subdivisions, environmental interests, business interests, and other persons affected by the proposed rule or amendment.
- (2) Consider documentation relevant to the need for, the environmental benefits or consequences of, other benefits of, and the technological feasibility of the proposed rule or rule amendment.
- (3) Specifically identify whether the proposed rule or rule amendment is being adopted or amended to enable the state to obtain or maintain approval to administer and enforce a federal environmental law or to participate in a federal environmental program, whether the proposed rule or rule amendment is more stringent than its federal counterpart, and, if the proposed rule or rule amendment is more stringent, the rationale for not incorporating its federal counterpart.
- (4) Include with the proposed rule or rule amendment and rule summary and fiscal analysis required to be filed with the Joint Committee on Agency Rule Review information relevant to the previously listed requirements.

(A) Were organizations that represent political subdivisions, environmental interests, business interests, and other persons affected by the proposed rule or amendment consulted? Yes

Please list each contact.

A draft of these rules was released for a 30-day public comment and review period ending June 18, 2021. The rules were released to Ohio EPA's electronic interested parties list, posted on Ohio EPA's regulations website and shared with interested industry parties. Several comments were received on Ohio EPA's rulemaking effort. Ohio EPA's response to comments document can be provided upon request. A copy of Ohio EPA's interested parties distribution list can be made available upon request.

(B) Was documentation that is relevant to the need for, the environmental benefits or consequences of, other benefits of, and the technological feasibility of the proposed rule or amendment considered? Yes

Please list the information provided and attach a copy of each piece of documentation to this form. (A SUMMARY OR INDEX MAY BE ATTACHED IN LIEU OF THE ACTUAL DOCUMENTATION.)

Clean Air Act, USEPA Control Technique Guidance Documents, LSC Style and Formatting Manual, and comments from interested parties.

- (C) **Is the proposed rule or rule amendment being adopted or amended to enable the state to obtain or maintain approval to administer and enforce a federal environmental law or to participate in a federal environmental program? Yes**

Is the proposed rule or rule amendment more stringent than its federal counterpart?
No Not Applicable

- (D) **If this is a rule amendment that is being adopted under a state statute that establishes standards with which the amendment is to comply, is the proposed rule amendment more stringent than the rule that it is proposing to amend? No**

Rule Summary and Fiscal Analysis

Part A - General Questions

Rule Number: 3745-21-27

Rule Type: Amendment

Rule Title/Tagline: Boat manufacturing.

Agency Name: Ohio Environmental Protection Agency

Division:

Address: 50 West Town Street, Suite 700 PO Box 1049 Columbus OH 43216-1049

Contact: Holly Kaloz **Phone:** 614-644-2760

Email: holly.kaloz@epa.ohio.gov

I. Rule Summary

1. **Is this a five year rule review?** Yes
 - A. **What is the rule's five year review date?** 11/29/2021
2. **Is this rule the result of recent legislation?** No
3. **What statute is this rule being promulgated under?** 119.03
4. **What statute(s) grant rule writing authority?** 3704.03(E)
5. **What statute(s) does the rule implement or amplify?** 3704.03(A), 3704.03(E)
6. **What are the reasons for proposing the rule?**

This rule is being filed to fulfill the requirements of ORC 106.03 (5-yr review) and to adopt mandatory Reasonably Available Control Technology (RACT) requirements for the Cincinnati and Cleveland 2015 ozone nonattainment areas.

7. **Summarize the rule's content, and if this is an amended rule, also summarize the rule's changes.**

This rule establishes emission reduction requirements for fiberglass boat manufacturing operations. The rule is being amended to expand CTG requirements to the Cincinnati nonattainment area.

8. **Does the rule incorporate material by reference? Yes**
9. **If the rule incorporates material by reference and the agency claims the material is exempt pursuant to R.C. 121.75, please explain the basis for the exemption and how an individual can find the referenced material.**

This rule contains references to the Ohio Administrative Code (OAC). While copies of these rules and statutes are generally available to the public through libraries and on-line sources, including the Ohio EPA website, ORC 121.76 (A) exempts such references from the provisions of ORC 121.71 through 121.75.

This rule also contains references to the Code of Federal Regulations (CFR). These rules are generally available through libraries, Ohio EPA and U.S. EPA websites. CFR references have also been dated to reference the specific version of the rules. ORC 121.75 (D) exempts such references from the requirements of ORC 121.71 through 121.74.

The rule also contains references to analytical test methods used to determine parameters for materials subject to this rule or other materials utilized by regulators and impacted parties to determine or achieve compliance with these rules. These test methods and materials are commonly known and utilized by laboratories performing this type of analytical work. Copies of these test methods are available in libraries and the websites of the method's supporting organization (ASTM, ANSI, NFPA, NACE, etc.).

Referenced materials are cited, dated and availability noted in paragraph (JJ) of rule 3745-21-01 of the Administrative Code.

10. **If revising or re-filing the rule, please indicate the changes made in the revised or re-filed version of the rule.**

Ohio EPA's website is converting to the State of Ohio IOP platform during the comment period for this rule-making, therefore the link to the rules in the public notice would no longer work. Ohio EPA is revise filing to change the public notice to the updated web location.

II. Fiscal Analysis

11. **Please estimate the increase / decrease in the agency's revenues or expenditures in the current biennium due to this rule.**

This will have no impact on revenues or expenditures.

0.00

Not Applicable

12. What are the estimated costs of compliance for all persons and/or organizations directly affected by the rule?

OAC Chapter 3745-21 has been in the OAC since 1972. The rules have evolved over the years to address requirements in the Clean Air Act to develop regulations as part of an effort to achieve the NAAQS for CO and ozone within the state. These rules and additional technical support were submitted to U.S. EPA for review and approval as part of the SIP.

This Chapter has been modified over the years to incorporate requirements for categories of sources for which U.S. EPA has indicated that RACT should apply. In general, the levels of control that are available have been evaluated and presented in a series of CTGs issued by U.S. EPA. There are also rules based on information provided by U.S. EPA for other sources which were identified as non-CTG RACT.

Given the many and varied types of processes that are regulated under OAC chapter 3745-21, it is difficult to give an exact cost of compliance with the rules in this chapter in a limited space. The cost of compliance with these rules can range from zero cost for a control technology such as a work practice or raw material change, to a few million dollars for the installation and operation of a mechanical control device. As part of the permitting process, facilities can perform a RACT analysis which allows them to determine, based on all technologies available, the best and most cost-effective control strategy for their facility.

This rule has been in effect for several years. Most of the costs associated with compliance with the existing requirements of this rule have been addressed in previous rulemakings and have been well established in the industry. There may be some additional cost of compliance related to the expansion of the requirements in the Cincinnati ozone nonattainment area in order to meet mandatory RACT requirements; however, many of the facilities affected by this expansion may already meet the requirements and not incur additional costs.

It should be noted that CTG based rules similar to Ohio's rules can also be found in Ohio's neighbor states and in any state containing a moderate ozone non-attainment area. Facilities wishing to locate in these types of areas will need to meet these requirements in all states.

13. Does the rule increase local government costs? (If yes, you must complete an RSFA Part B). Yes

14. Does the rule regulate environmental protection? (If yes, you must complete an RSFA Part C). Yes
15. If the rule imposes a regulation fee, explain how the fee directly relates to your agency's cost in regulating the individual or business.

Not Applicable

III. Common Sense Initiative (CSI) Questions

16. Was this rule filed with the Common Sense Initiative Office? Yes
17. Does this rule have an adverse impact on business? Yes
 - A. Does this rule require a license, permit, or any other prior authorization to engage in or operate a line of business? Yes

An affected facility is required to submit a notification to the Ohio EPA district office or local air agency in writing that states that the facility is subject to this rule. A new permit is required if the facility does not already possess a complying permit.

- B. Does this rule impose a criminal penalty, a civil penalty, or another sanction, or create a cause of action, for failure to comply with its terms? No
- C. Does this rule require specific expenditures or the report of information as a condition of compliance? Yes

The rule requires periodic submission of reports that typically include deviations from requirements and exceedances of emissions limits. These costs are discussed in the fiscal analysis for this rule.

- D. Is it likely that the rule will directly reduce the revenue or increase the expenses of the lines of business of which it will apply or applies? No

IV. Regulatory Restrictions (This section only applies to agencies indicated in R.C. 121.95 (A))

18. Are you adding a new or removing an existing regulatory restriction as defined in R.C. 121.95? Yes

A. How many new regulatory restrictions do you propose adding? 4

New restriction: OAC 3745-21-27(L)(1): The owner or operator of a boat manufacturing facility that is subject to this rule, is located in located in Ashtabula, Cuyahoga, Geauga, Lake, Lorain, Medina, Portage, or Summit county, and has an initial startup before May 12, 2011 shall notify the appropriate Ohio EPA district office or local air agency in writing that the boat manufacturing facility is subject to this rule not later than July 11, 2011 or within sixty days after the boat manufacturing facility becomes subject to this rule, providing the information specified in paragraph (L)(5) of this rule.

Removed restriction 1: OAC 3745-21-09(B)(3)(k): A copy of such record shall be sent to the director within forty-five days after the exceedance occurs. (deleted sentence; added deadline to previous sentence)

Removed restriction 2: OAC 3745-21-09(B)(3)(m): These quarterly reports shall be submitted by April thirtieth, July thirty-first, October thirty-first, and January thirty-first, and shall cover the records for the previous calendar quarters. (deleted sentence; added deadlines to previous sentence)

New restriction: OAC 3745-21-27(L)(2): The owner or operator of a boat manufacturing facility that is subject to this rule, is located in Ashtabula, Cuyahoga, Geauga, Lake, Lorain, Medina, Portage, or Summit county, and has an initial startup on or after May 12, 2011 shall notify the appropriate Ohio EPA district office or local air agency in writing that the boat manufacturing facility is subject to this rule not later than either the date of initial startup of the boat manufacturing facility or July 11, 2011 (whichever is later), providing the information specified in paragraph (L)(5) of this rule.

Removed restriction 1: OAC 3745-21-09(B)(4)(c): These quarterly reports shall be submitted by April thirtieth, July thirty-first, October thirty-first, and January thirty-first, and shall cover the records for the previous calendar quarters. (deleted sentence; added deadlines to previous sentence)

Removed restriction 2: OAC 3745-21-09(B)(4)(d): The continuous monitoring and recording devices shall be installed and placed in operation either within one hundred eighty days of March 31, 1993 or by the date of operation of any new control equipment installed for the source after March 31, 1993 to achieve compliance with the VOC control requirements of this rule. (deleted sentence; added deadlines to previous sentence)

New restriction: OAC 3745-21-27(L)(3): The owner or operator of a boat manufacturing facility that is subject to this rule, is located in Butler, Clermont, Hamilton or Warren county, and has an initial startup before the effective date of this rule shall notify the appropriate Ohio EPA district office or local air agency in writing that the boat manufacturing facility is subject to this rule not later than sixty days after the effective date of this rule, providing the information specified in paragraph (L)(5) of this rule.

Removed restriction 1: OAC 3745-21-09(B)(5): the alternative recordkeeping and reporting program shall supersede paragraph (B)(3) or (B)(4) of this rule and shall be specified in the terms and conditions of the permit (removed shall)

Removed restriction 2: OAC 3745-21-09(B)(5): Any alternative recordkeeping and reporting program approved by the director shall also be approved by the USEPA as a revision to the state implementation plan. (deleted sentence; added "and USEPA as a revision to the state implementation plan" to previous sentence)

New restriction: OAC 3745-21-27(L)(4): The owner or operator of a boat manufacturing facility that is subject to this rule, is located in Butler, Clermont, Hamilton or Warren county, and has an initial startup on or after the effective date of this rule shall notify the appropriate Ohio EPA district office or local air agency in writing that the boat manufacturing facility is subject to this rule not later than either the date of initial startup of the boat manufacturing facility or sixty days after the effective date of this rule 3745-21-27 19 (whichever is later), providing the information specified in paragraph (L)(5) of this rule.

Removed restriction 1: OAC 3745-21-09(C): For any source located in Ashtabula, Cuyahoga, Geauga, Lake, Lorain, Medina, Portage, or Summit county subject to paragraph (C) of this rule, the requirement to comply with paragraph (C) of this rule shall terminate at such time the source becomes subject to and complies with rule 3745-21-29 of the Administrative Code. (changed "shall terminate" to "terminates")

Removed restriction 2: OAC 3745-21-09(C)(1)(a)(ii): RT shall be calculated as follows: (changed "shall be" to "is")

B. How many existing regulatory restrictions do you propose removing? 5

Removed restriction: OAC 3745-21-27(L)(5): The owner or operator of a boat manufacturing facility that is subject to this rule with an initial startup date

before May 12, 2011 shall notify the Ohio EPA district office or local air agency in writing that the boat manufacturing facility is subject to this rule. (moved)

Removed restriction: OAC 3745-21-27(L)(5): The notification, which shall be submitted not later than July 11, 2011 or within sixty days after the boat manufacturing facility becomes subject to this rule, (moved)

Removed restriction: OAC 3745-21-27(L)(2): The owner or operator of a boat manufacturing facility that is subject to this rule with an initial startup date on or after May 12, 2011 notify the Ohio EPA district office or local air agency in writing that the boat manufacturing facility is subject to this rule. (moved)

Removed restriction: OAC 3745-21-27(L)(2): The notification, which shall be submitted not later than either the date of initial startup of the boat manufacturing facility or July 11, 2011, whichever is later (moved)

Removed restriction: OAC 3745-21-27(L)(2): shall provide the information listed under paragraph (L)(1) of this rule. (moved)

Rule Summary and Fiscal Analysis

Part B - Local Governments Questions

1. Does the rule increase costs for:

A. Public School Districts	No
B. County Government	Yes
C. Township Government	Yes
D. City and Village Governments	Yes

2. Please estimate the total cost, in dollars, of compliance with the rule for the affected local government(s). If you cannot give a dollar cost, explain how the local government is financially impacted.

OAC Chapter 3745-21 has been in the OAC since 1972. The rules have evolved over the years to address requirements in the Clean Air Act to develop regulations as part of an effort to achieve the NAAQS for CO and ozone within the state. These rules and additional technical support were submitted to U.S. EPA for review and approval as part of the SIP.

This Chapter has been modified over the years to incorporate requirements for categories of sources for which U.S. EPA has indicated that RACT should apply. In general, the levels of control that are available have been evaluated and presented in a series of CTGs issued by U.S. EPA. There are also rules based on information provided by U.S. EPA for other sources which were identified as non-CTG RACT.

Given the many and varied types of processes that are regulated under OAC chapter 3745-21, it is difficult to give an exact cost of compliance with the rules in this chapter in a limited space. The cost of compliance with these rules can range from zero cost for a control technology such as a work practice or raw material change, to a few million dollars for the installation and operation of a mechanical control device. As part of the permitting process, facilities can perform a RACT analysis which allows them to determine, based on all technologies available, the best and most cost-effective control strategy for their facility.

This rule has been in effect for several years. Most of the costs associated with compliance with the existing requirements of this rule have been addressed in previous rulemakings and have been well established in the industry. There may be some additional cost of compliance related to the expansion of the requirements in the

Cincinnati ozone nonattainment area in order to meet mandatory RACT requirements; however, many of the facilities affected by this expansion may already meet the requirements and not incur additional costs.

It should be noted that CTG based rules similar to Ohio's rules can also be found in Ohio's neighbor states and in any state containing a moderate ozone non-attainment area. Facilities wishing to locate in these types of areas will need to meet these requirements in all states.

3. **Is this rule the result of a federal government requirement? Yes**
 - A. **If yes, does this rule do more than the federal government requires? No**
 - B. **If yes, what are the costs, in dollars, to the local government for the regulation that exceeds the federal government requirement?**

Not Applicable
4. **Please provide an estimated cost of compliance for the proposed rule if it has an impact on the following:**
 - A. **Personnel Costs**

See above.
 - B. **New Equipment or Other Capital Costs**

See above.
 - C. **Operating Costs**

See above.
 - D. **Any Indirect Central Service Costs**

See above.
 - E. **Other Costs**

See above.
5. **Please explain how the local government(s) will be able to pay for the increased costs associated with the rule.**

Ohio EPA acknowledges that there will be an increase in costs associated with the expansion of the requirements in the Cincinnati ozone nonattainment area in order

to meet mandatory RACT requirements; however, many of the facilities affected by this expansion may already meet the requirements and not incur additional costs. Facilities that are affected will need to adjust their operational and maintenance budgets accordingly. These budgets are typically financed through a general fund.

6. What will be the impact on economic development, if any, as the result of this rule?

These rules are being promulgated to implement federal requirements for the application of reasonably available control technology to source categories of VOC in moderate ozone non-attainment areas. Rules governing VOC for these source types are in effect in many places around the country, and are not unique to the area covered by this rule. Therefore, any potential economic impact in the affected area would be minimal.

Reducing emissions benefits the affected area by providing a cost savings and economic benefit to stakeholders through reduced pollution. Not only does reducing pollution provide for better enjoyment of the states resources through cleaner air but also reduces property damage caused by pollution, reduces illnesses and reduces healthcare costs. The cost benefits, although difficult to quantify, are significant and may exceed the cost incurred by regulated entities required to comply with VOC RACT rules.

Rule Summary and Fiscal Analysis

Part C - Environmental Rule Questions

Pursuant to Am. Sub. H.B. 106 of the 121st General Assembly, prior to adopting a rule or an amendment to a rule dealing with environmental protection, or containing a component dealing with environmental protection, a state agency shall:

- (1) Consult with organizations that represent political subdivisions, environmental interests, business interests, and other persons affected by the proposed rule or amendment.
- (2) Consider documentation relevant to the need for, the environmental benefits or consequences of, other benefits of, and the technological feasibility of the proposed rule or rule amendment.
- (3) Specifically identify whether the proposed rule or rule amendment is being adopted or amended to enable the state to obtain or maintain approval to administer and enforce a federal environmental law or to participate in a federal environmental program, whether the proposed rule or rule amendment is more stringent than its federal counterpart, and, if the proposed rule or rule amendment is more stringent, the rationale for not incorporating its federal counterpart.
- (4) Include with the proposed rule or rule amendment and rule summary and fiscal analysis required to be filed with the Joint Committee on Agency Rule Review information relevant to the previously listed requirements.

(A) Were organizations that represent political subdivisions, environmental interests, business interests, and other persons affected by the proposed rule or amendment consulted? Yes

Please list each contact.

A draft of these rules was released for a 30-day public comment and review period ending June 18, 2021. The rules were released to Ohio EPA's electronic interested parties list, posted on Ohio EPA's regulations website and shared with interested industry parties. Several comments were received on Ohio EPA's rulemaking effort. Ohio EPA's response to comments document can be provided upon request. A copy of Ohio EPA's interested parties distribution list can be made available upon request.

(B) Was documentation that is relevant to the need for, the environmental benefits or consequences of, other benefits of, and the technological feasibility of the proposed rule or amendment considered? Yes

Please list the information provided and attach a copy of each piece of documentation to this form. (A SUMMARY OR INDEX MAY BE ATTACHED IN LIEU OF THE ACTUAL DOCUMENTATION.)

Clean Air Act, USEPA Control Technique Guidance Documents, LSC Style and Formatting Manual, and comments from interested parties.

- (C) Is the proposed rule or rule amendment being adopted or amended to enable the state to obtain or maintain approval to administer and enforce a federal environmental law or to participate in a federal environmental program? Yes**

Is the proposed rule or rule amendment more stringent than its federal counterpart?
No Not Applicable

- (D) If this is a rule amendment that is being adopted under a state statute that establishes standards with which the amendment is to comply, is the proposed rule amendment more stringent than the rule that it is proposing to amend? No**

Rule Summary and Fiscal Analysis

Part A - General Questions

Rule Number: 3745-21-28

Rule Type: Amendment

Rule Title/Tagline: Miscellaneous industrial adhesives and sealants.

Agency Name: Ohio Environmental Protection Agency

Division:

Address: 50 West Town Street, Suite 700 PO Box 1049 Columbus OH 43216-1049

Contact: Holly Kaloz **Phone:** 614-644-2760

Email: holly.kaloz@epa.ohio.gov

I. Rule Summary

1. **Is this a five year rule review?** Yes
 - A. **What is the rule's five year review date?** 11/29/2021
2. **Is this rule the result of recent legislation?** No
3. **What statute is this rule being promulgated under?** 119.03
4. **What statute(s) grant rule writing authority?** 3704.03(E)
5. **What statute(s) does the rule implement or amplify?** 3704.03(A), 3704.03(E)
6. **What are the reasons for proposing the rule?**

This rule is being filed to fulfill the requirements of ORC 106.03 (5-yr review) and to adopt mandatory Reasonably Available Control Technology (RACT) requirements for the Cincinnati and Cleveland 2015 ozone nonattainment areas.

7. **Summarize the rule's content, and if this is an amended rule, also summarize the rule's changes.**

This rule establishes emission reduction requirements for miscellaneous industrial adhesives and sealants. Amendments pursuant to the 5-year review are being made to add two exemptions to paragraph (A)(3) to bring the rule in line with the CTG

for Miscellaneous Industrial Adhesives. In addition, amendments are being made to expand CTG requirements to the Cincinnati nonattainment area.

- 8. Does the rule incorporate material by reference? Yes**
- 9. If the rule incorporates material by reference and the agency claims the material is exempt pursuant to R.C. 121.75, please explain the basis for the exemption and how an individual can find the referenced material.**

This rule contains references to the Ohio Administrative Code (OAC). While copies of these rules and statutes are generally available to the public through libraries and on-line sources, including the Ohio EPA website, ORC 121.76 (A) exempts such references from the provisions of ORC 121.71 through 121.75.

This rule also contains references to the Code of Federal Regulations (CFR). These rules are generally available through libraries, Ohio EPA and U.S. EPA websites. CFR references have also been dated to reference the specific version of the rules. ORC 121.75 (D) exempts such references from the requirements of ORC 121.71 through 121.74.

The rule also contains references to analytical test methods used to determine parameters for materials subject to this rule or other materials utilized by regulators and impacted parties to determine or achieve compliance with these rules. These test methods and materials are commonly known and utilized by laboratories performing this type of analytical work. Copies of these test methods are available in libraries and the websites of the method's supporting organization (ASTM, ANSI, NFPA, NACE, etc.).

Referenced materials are cited, dated and availability noted in paragraph (JJ) of rule 3745-21-01 of the Administrative Code.

- 10. If revising or re-filing the rule, please indicate the changes made in the revised or re-filed version of the rule.**

Ohio EPA's website is converting to the State of Ohio IOP platform during the comment period for this rule-making, therefore the link to the rules in the public notice would no longer work. Ohio EPA is revise filing to change the public notice to the updated web location.

II. Fiscal Analysis

- 11. Please estimate the increase / decrease in the agency's revenues or expenditures in the current biennium due to this rule.**

This will have no impact on revenues or expenditures.

0.00

Not Applicable

12. What are the estimated costs of compliance for all persons and/or organizations directly affected by the rule?

OAC Chapter 3745-21 has been in the OAC since 1972. The rules have evolved over the years to address requirements in the Clean Air Act to develop regulations as part of an effort to achieve the NAAQS for CO and ozone within the state. These rules and additional technical support were submitted to U.S. EPA for review and approval as part of the SIP.

This Chapter has been modified over the years to incorporate requirements for categories of sources for which U.S. EPA has indicated that RACT should apply. In general, the levels of control that are available have been evaluated and presented in a series of CTGs issued by U.S. EPA. There are also rules based on information provided by U.S. EPA for other sources which were identified as non-CTG RACT.

Given the many and varied types of processes that are regulated under OAC chapter 3745-21, it is difficult to give an exact cost of compliance with the rules in this chapter in a limited space. The cost of compliance with these rules can range from zero cost for a control technology such as a work practice or raw material change, to a few million dollars for the installation and operation of a mechanical control device. As part of the permitting process, facilities can perform a RACT analysis which allows them to determine, based on all technologies available, the best and most cost-effective control strategy for their facility.

This rule has been in effect for several years. Most of the costs associated with compliance with the existing requirements of this rule have been addressed in previous rulemakings and have been well established in the industry. There may be some additional cost of compliance related to the expansion of the requirements in the Cincinnati ozone nonattainment area in order to meet mandatory RACT requirements; however, many of the facilities affected by this expansion may already meet the requirements and not incur additional costs.

It should be noted that CTG based rules similar to Ohio's rules can also be found in Ohio's neighbor states and in any state containing a moderate ozone non-attainment area. Facilities wishing to locate in these types of areas will need to meet these requirements in all states.

13. **Does the rule increase local government costs? (If yes, you must complete an RSFA Part B). Yes**
14. **Does the rule regulate environmental protection? (If yes, you must complete an RSFA Part C). Yes**
15. **If the rule imposes a regulation fee, explain how the fee directly relates to your agency's cost in regulating the individual or business.**

Not Applicable

III. Common Sense Initiative (CSI) Questions

16. **Was this rule filed with the Common Sense Initiative Office? Yes**
17. **Does this rule have an adverse impact on business? Yes**

- A. **Does this rule require a license, permit, or any other prior authorization to engage in or operate a line of business? Yes**

An affected facility is required to submit a notification to the Ohio EPA district office or local air agency in writing that states that the facility is subject to this rule. A new permit is required if the facility does not already possess a complying permit.

- B. **Does this rule impose a criminal penalty, a civil penalty, or another sanction, or create a cause of action, for failure to comply with its terms? No**

- C. **Does this rule require specific expenditures or the report of information as a condition of compliance? Yes**

The rule requires periodic submission of reports that typically include deviations from requirements and exceedances of emissions limits. These costs are discussed in the fiscal analysis for this rule.

- D. **Is it likely that the rule will directly reduce the revenue or increase the expenses of the lines of business of which it will apply or applies? No**

IV. Regulatory Restrictions (This section only applies to agencies indicated in R.C. 121.95 (A))

18. Are you adding a new or removing an existing regulatory restriction as defined in R.C. 121.95? Yes

A. How many new regulatory restrictions do you propose adding? 4

New restriction: OAC 3745-21-28(G)(1): The owner or operator of a miscellaneous industrial adhesive and sealant application process that is subject to this rule, is located in located in Ashtabula, Cuyahoga, Geauga, Lake, Lorain, Medina, Portage, or Summit county, and has an initial startup before May 12, 2011 shall notify the appropriate Ohio EPA district office or local air agency in writing that the process is subject to this rule not later than July 11, 2011 (or within sixty days after the process becomes subject to this rule), providing the information specified in paragraph (G)(5) of this rule.

Removed restriction 1: OAC 3745-21-09(C)(5)(b): A copy of such monthly record shall be sent to the director within thirty days following the end of the calendar month. (deleted sentence; added deadline to previous sentence)

Removed restriction 2: OAC 3745-21-09(C)(7)(b): A copy of such monthly record shall be sent to the director within thirty days following the end of the calendar month. (deleted sentence; added deadline to previous sentence)

New restriction: OAC 3745-21-28(G)(2): The owner or operator of a miscellaneous industrial adhesive and sealant application process that is subject to this rule, is located in Ashtabula, Cuyahoga, Geauga, Lake, Lorain, Medina, Portage, or Summit county, and has an initial startup on or after May 12, 2011 shall notify the appropriate Ohio EPA district office or local air agency in writing that the process is subject to this rule not later than either the date of initial startup of the subject process or July 11, 2011 (whichever is later), providing the information specified in paragraph (G)(5) of this rule.

Removed restriction 1: OAC 3745-21-09(C)(8)(d): The calculated, controlled VOC emission rate, in mass of VOC per unit volume of coating solids, as applied. The controlled VOC emission rate shall be: (changed to "The calculated, controlled VOC emission rate, in mass of VOC per unit volume of coating solids, as applied, calculated using the following:")

Removed restriction 2: OAC 3745-21-09(C)(9): A copy of such monthly record shall be sent to the director within thirty days following the end of the calendar month. (deleted sentence; added deadline to previous sentence)

New restriction: OAC 3745-21-28(G)(3): The owner or operator of a miscellaneous industrial adhesive and sealant application process that is subject to this rule, is located in Butler, Clermont, Hamilton or Warren county, and has an initial startup of shipbuilding or ship repair operations before the effective date of this rule shall notify the appropriate Ohio EPA district office or local air agency in writing that the process is subject to this rule not later than sixty days after the effective date of this rule, providing the information specified in paragraph (G)(5) of this rule.

Removed restriction 1: OAC 3745-21-09(H)(3): Paragraphs (H)(1) and (H)(2) of this rule shall not apply to the application of organisol or plastisol coatings. (changed to "The application of organisol or plastisol coatings are exempt from paragraphs (H)(1) and (H)(2) of this rule.")

Removed restriction 2: OAC 3745-21-09(I)(4)(b)(iii): Paragraphs (I)(4)(a) and (I)(4)(d) of this rule shall not apply to the following: (changed "shall not apply" to "are not applicable")

New restriction: OAC 3745-21-28(G)(4): The owner or operator of a miscellaneous industrial adhesive and sealant application process that is subject to this rule, is located in Butler, Clermont, Hamilton or Warren county, and has an initial startup of shipbuilding or ship repair operations on or after the effective date of this rule shall notify the appropriate Ohio EPA district office or local air agency in writing that the process is subject to this rule not later than either the date of initial startup of the subject process or sixty days after the effective date of this rule (whichever is later), providing the information specified in paragraph (G)(5) of this rule.

Removed restriction 1: OAC 3745-21-09(K)(2): The emission limit under paragraph (K)(1) of this rule shall not apply toâ (changed "shall" to "does")

Removed restriction 2: OAC 3745-21-09(K)(4): The emission limit under paragraph (K)(1) of this rule shall not apply toâ (changed "shall" to "does")

B. How many existing regulatory restrictions do you propose removing? 5

Removed restriction: OAC 3745-21-28(G)(5): The owner or operator of a miscellaneous industrial adhesive and sealant application process that is subject to this rule with an initial startup date before May 12, 2011 shall notify the Ohio EPA district office or local air agency in writing that the process is subject to this rule. (moved)

Removed restriction: OAC 3745-21-28(G)(5): The notification, which shall be submitted not later than July 11, 2011 (or within sixty days after the process becomes subject to this rule) (moved)

Removed restriction: OAC 3745-21-28(G)(2): The owner or operator of a miscellaneous industrial adhesive and sealant application process that is subject to this rule with an initial startup date on or after May 12, 2011 shall notify the Ohio EPA district office or local air agency in writing that the process is subject to this rule. (moved)

Removed restriction: OAC 3745-21-28(G)(2): The notification, which shall be submitted not later than either the date of initial startup of the subject process, or July 11, 2011 of this rule (whichever is later) (moved)

Removed restriction: OAC 3745-21-28(G)(2): shall provide the information listed under paragraph (G)(1) of this rule. (moved)

Rule Summary and Fiscal Analysis

Part B - Local Governments Questions

1. Does the rule increase costs for:

A. Public School Districts	No
B. County Government	Yes
C. Township Government	Yes
D. City and Village Governments	Yes

2. Please estimate the total cost, in dollars, of compliance with the rule for the affected local government(s). If you cannot give a dollar cost, explain how the local government is financially impacted.

OAC Chapter 3745-21 has been in the OAC since 1972. The rules have evolved over the years to address requirements in the Clean Air Act to develop regulations as part of an effort to achieve the NAAQS for CO and ozone within the state. These rules and additional technical support were submitted to U.S. EPA for review and approval as part of the SIP.

This Chapter has been modified over the years to incorporate requirements for categories of sources for which U.S. EPA has indicated that RACT should apply. In general, the levels of control that are available have been evaluated and presented in a series of CTGs issued by U.S. EPA. There are also rules based on information provided by U.S. EPA for other sources which were identified as non-CTG RACT.

Given the many and varied types of processes that are regulated under OAC chapter 3745-21, it is difficult to give an exact cost of compliance with the rules in this chapter in a limited space. The cost of compliance with these rules can range from zero cost for a control technology such as a work practice or raw material change, to a few million dollars for the installation and operation of a mechanical control device. As part of the permitting process, facilities can perform a RACT analysis which allows them to determine, based on all technologies available, the best and most cost-effective control strategy for their facility.

This rule has been in effect for several years. Most of the costs associated with compliance with the existing requirements of this rule have been addressed in previous rulemakings and have been well established in the industry. There may be some additional cost of compliance related to the expansion of the requirements in the

Cincinnati ozone nonattainment area in order to meet mandatory RACT requirements; however, many of the facilities affected by this expansion may already meet the requirements and not incur additional costs.

It should be noted that CTG based rules similar to Ohio's rules can also be found in Ohio's neighbor states and in any state containing a moderate ozone non-attainment area. Facilities wishing to locate in these types of areas will need to meet these requirements in all states.

3. **Is this rule the result of a federal government requirement? Yes**
 - A. **If yes, does this rule do more than the federal government requires? No**
 - B. **If yes, what are the costs, in dollars, to the local government for the regulation that exceeds the federal government requirement?**

Not Applicable
4. **Please provide an estimated cost of compliance for the proposed rule if it has an impact on the following:**
 - A. **Personnel Costs**

See above.
 - B. **New Equipment or Other Capital Costs**

See above.
 - C. **Operating Costs**

See above.
 - D. **Any Indirect Central Service Costs**

See above.
 - E. **Other Costs**

See above.
5. **Please explain how the local government(s) will be able to pay for the increased costs associated with the rule.**

Ohio EPA acknowledges that there will be an increase in costs associated with the expansion of the requirements in the Cincinnati ozone nonattainment area in order

to meet mandatory RACT requirements; however, many of the facilities affected by this expansion may already meet the requirements and not incur additional costs. Facilities that are affected will need to adjust their operational and maintenance budgets accordingly. These budgets are typically financed through a general fund.

6. What will be the impact on economic development, if any, as the result of this rule?

These rules are being promulgated to implement federal requirements for the application of reasonably available control technology to source categories of VOC in moderate ozone non-attainment areas. Rules governing VOC for these source types are in effect in many places around the country, and are not unique to the area covered by this rule. Therefore, any potential economic impact in the affected area would be minimal.

Reducing emissions benefits the affected area by providing a cost savings and economic benefit to stakeholders through reduced pollution. Not only does reducing pollution provide for better enjoyment of the states resources through cleaner air but also reduces property damage caused by pollution, reduces illnesses and reduces healthcare costs. The cost benefits, although difficult to quantify, are significant and may exceed the cost incurred by regulated entities required to comply with VOC RACT rules.

Rule Summary and Fiscal Analysis

Part C - Environmental Rule Questions

Pursuant to Am. Sub. H.B. 106 of the 121st General Assembly, prior to adopting a rule or an amendment to a rule dealing with environmental protection, or containing a component dealing with environmental protection, a state agency shall:

- (1) Consult with organizations that represent political subdivisions, environmental interests, business interests, and other persons affected by the proposed rule or amendment.
- (2) Consider documentation relevant to the need for, the environmental benefits or consequences of, other benefits of, and the technological feasibility of the proposed rule or rule amendment.
- (3) Specifically identify whether the proposed rule or rule amendment is being adopted or amended to enable the state to obtain or maintain approval to administer and enforce a federal environmental law or to participate in a federal environmental program, whether the proposed rule or rule amendment is more stringent than its federal counterpart, and, if the proposed rule or rule amendment is more stringent, the rationale for not incorporating its federal counterpart.
- (4) Include with the proposed rule or rule amendment and rule summary and fiscal analysis required to be filed with the Joint Committee on Agency Rule Review information relevant to the previously listed requirements.

(A) Were organizations that represent political subdivisions, environmental interests, business interests, and other persons affected by the proposed rule or amendment consulted? Yes

Please list each contact.

A draft of these rules was released for a 30-day public comment and review period ending June 18, 2021. The rules were released to Ohio EPA's electronic interested parties list, posted on Ohio EPA's regulations website and shared with interested industry parties. Several comments were received on Ohio EPA's rulemaking effort. Ohio EPA's response to comments document can be provided upon request. A copy of Ohio EPA's interested parties distribution list can be made available upon request.

(B) Was documentation that is relevant to the need for, the environmental benefits or consequences of, other benefits of, and the technological feasibility of the proposed rule or amendment considered? Yes

Please list the information provided and attach a copy of each piece of documentation to this form. (A SUMMARY OR INDEX MAY BE ATTACHED IN LIEU OF THE ACTUAL DOCUMENTATION.)

Clean Air Act, USEPA Control Technique Guidance Documents, LSC Style and Formatting Manual, and comments from interested parties.

- (C) **Is the proposed rule or rule amendment being adopted or amended to enable the state to obtain or maintain approval to administer and enforce a federal environmental law or to participate in a federal environmental program? Yes**

Is the proposed rule or rule amendment more stringent than its federal counterpart?
No Not Applicable

- (D) **If this is a rule amendment that is being adopted under a state statute that establishes standards with which the amendment is to comply, is the proposed rule amendment more stringent than the rule that it is proposing to amend? No**

Rule Summary and Fiscal Analysis

Part A - General Questions

Rule Number: 3745-21-29

Rule Type: Amendment

Rule Title/Tagline: Control of volatile organic compound emissions from automobile and light-duty truck assembly coating operations, heavier vehicle assembly coating operations, and cleaning operations associated with these coating operations.

Agency Name: Ohio Environmental Protection Agency

Division:

Address: 50 West Town Street, Suite 700 PO Box 1049 Columbus OH 43216-1049

Contact: Holly Kaloz **Phone:** 614-644-2760

Email: holly.kaloz@epa.ohio.gov

I. Rule Summary

1. **Is this a five year rule review?** Yes
 - A. **What is the rule's five year review date?** 11/29/2021
2. **Is this rule the result of recent legislation?** No
3. **What statute is this rule being promulgated under?** 119.03
4. **What statute(s) grant rule writing authority?** 3704.03(E)
5. **What statute(s) does the rule implement or amplify?** 3704.03(A), 3704.03(E)
6. **What are the reasons for proposing the rule?**

This rule is being filed to fulfill the requirements of ORC 106.03 (5-yr review) and to adopt mandatory Reasonably Available Control Technology (RACT) requirements for the Cincinnati and Cleveland 2015 ozone nonattainment areas.

7. **Summarize the rule's content, and if this is an amended rule, also summarize the rule's changes.**

This rule establishes emission reduction requirements of volatile organic compound emissions from automobile and light-duty truck assembly coating operations, heavier vehicle assembly coating operations, and associated facility coating operations. The rule is being amended to expand CTG requirements to the Cincinnati nonattainment area.

8. **Does the rule incorporate material by reference? Yes**
9. **If the rule incorporates material by reference and the agency claims the material is exempt pursuant to R.C. 121.75, please explain the basis for the exemption and how an individual can find the referenced material.**

This rule contains references to the Ohio Administrative Code (OAC). While copies of these rules and statutes are generally available to the public through libraries and on-line sources, including the Ohio EPA website, ORC 121.76 (A) exempts such references from the provisions of ORC 121.71 through 121.75.

This rule also contains references to the Code of Federal Regulations (CFR). These rules are generally available through libraries, Ohio EPA and U.S. EPA websites. CFR references have also been dated to reference the specific version of the rules. ORC 121.75 (D) exempts such references from the requirements of ORC 121.71 through 121.74.

The rule also contains references to analytical test methods used to determine parameters for materials subject to this rule or other materials utilized by regulators and impacted parties to determine or achieve compliance with these rules. These test methods and materials are commonly known and utilized by laboratories performing this type of analytical work. Copies of these test methods are available in libraries and the websites of the method's supporting organization (ASTM, ANSI, NFPA, NACE, etc.).

Referenced materials are cited, dated and availability noted in paragraph (JJ) of rule 3745-21-01 of the Administrative Code.

10. **If revising or re-filing the rule, please indicate the changes made in the revised or re-filed version of the rule.**

Ohio EPA's website is converting to the State of Ohio IOP platform during the comment period for this rule-making, therefore the link to the rules in the public notice would no longer work. Ohio EPA is revise filing to change the public notice to the updated web location.

II. Fiscal Analysis

11. Please estimate the increase / decrease in the agency's revenues or expenditures in the current biennium due to this rule.

This will have no impact on revenues or expenditures.

0.00

Not Applicable

12. What are the estimated costs of compliance for all persons and/or organizations directly affected by the rule?

OAC Chapter 3745-21 has been in the OAC since 1972. The rules have evolved over the years to address requirements in the Clean Air Act to develop regulations as part of an effort to achieve the NAAQS for CO and ozone within the state. These rules and additional technical support were submitted to U.S. EPA for review and approval as part of the SIP.

This Chapter has been modified over the years to incorporate requirements for categories of sources for which U.S. EPA has indicated that RACT should apply. In general, the levels of control that are available have been evaluated and presented in a series of CTGs issued by U.S. EPA. There are also rules based on information provided by U.S. EPA for other sources which were identified as non-CTG RACT.

Given the many and varied types of processes that are regulated under OAC chapter 3745-21, it is difficult to give an exact cost of compliance with the rules in this chapter in a limited space. The cost of compliance with these rules can range from zero cost for a control technology such as a work practice or raw material change, to a few million dollars for the installation and operation of a mechanical control device. As part of the permitting process, facilities can perform a RACT analysis which allows them to determine, based on all technologies available, the best and most cost-effective control strategy for their facility.

This rule has been in effect for several years. Most of the costs associated with compliance with the existing requirements of this rule have been addressed in previous rulemakings and have been well established in the industry. There may be some additional cost of compliance related to the expansion of the requirements in the Cincinnati ozone nonattainment area in order to meet mandatory RACT requirements; however, many of the facilities affected by this expansion may already meet the requirements and not incur additional costs.

It should be noted that CTG based rules similar to Ohio's rules can also be found in Ohio's neighbor states and in any state containing a moderate ozone non-attainment

area. Facilities wishing to locate in these types of areas will need to meet these requirements in all states.

13. **Does the rule increase local government costs? (If yes, you must complete an RSFA Part B). Yes**
14. **Does the rule regulate environmental protection? (If yes, you must complete an RSFA Part C). Yes**
15. **If the rule imposes a regulation fee, explain how the fee directly relates to your agency's cost in regulating the individual or business.**

Not Applicable

III. Common Sense Initiative (CSI) Questions

16. **Was this rule filed with the Common Sense Initiative Office? Yes**
17. **Does this rule have an adverse impact on business? Yes**

- A. **Does this rule require a license, permit, or any other prior authorization to engage in or operate a line of business? Yes**

An affected facility is required to submit a notification to the Ohio EPA district office or local air agency in writing that states that the facility is subject to this rule. A new permit is required if the facility does not already possess a complying permit.

- B. **Does this rule impose a criminal penalty, a civil penalty, or another sanction, or create a cause of action, for failure to comply with its terms? No**
- C. **Does this rule require specific expenditures or the report of information as a condition of compliance? Yes**

The rule requires periodic submission of reports that typically include deviations from requirements and exceedances of emissions limits. These costs are discussed in the fiscal analysis for this rule.

- D. **Is it likely that the rule will directly reduce the revenue or increase the expenses of the lines of business of which it will apply or applies? No**

IV. Regulatory Restrictions (This section only applies to agencies indicated in R.C. 121.95 (A))

18. Are you adding a new or removing an existing regulatory restriction as defined in R.C. 121.95? Yes

A. How many new regulatory restrictions do you propose adding? 4

New restriction: OAC 3745-21-29(I)(1): The owner or operator of a coating operation that is subject to this rule, is located in located in Ashtabula, Cuyahoga, Geauga, Lake, Lorain, Medina, Portage, or Summit county, and has an initial startup of the coating operation before May 12, 2011 shall notify the appropriate Ohio EPA district office or local air agency in writing that the coating operation is subject to this rule not later than July 11, 2011 (or within sixty days after the coating operation becomes subject to this rule), providing the information specified in paragraph (I)(5) of this rule.

Removed restriction 1: OAC 3745-21-09(K)(5): The emission limit under paragraph (K)(1) of this rule shall not apply toâ€ (changed "shall" to "does")

Removed restriction 2: OAC 3745-21-09(K)(6)(b)(ii): Paragraphs (K)(6)(a) and (K)(6)(e) of this rule shall not apply to the following: (changed "shall" to "do")

New restriction: OAC 3745-21-29(I)(2): The owner or operator of a coating operation that is subject to this rule, is located in Ashtabula, Cuyahoga, Geauga, Lake, Lorain, Medina, Portage, or Summit county, and has an initial startup of the coating operation on or after May 12, 2011 shall notify the appropriate Ohio EPA district office or local air agency in writing that the coating operation is subject to this rule not later than either the date of initial startup of the the subject coating operation or July 11, 2011 (whichever is later), providing the information specified in paragraph (I)(5) of this rule.

Removed restriction 1: OAC 3745-21-09(L)(3): Any owner or operator of a fixed roof tank that is not exempted pursuant to paragraph (L)(2) of this rule shall maintain records of the following information in a readily accessible location for at least five years and shall make copies of the records (removed shall)

Removed restriction 2: OAC 3745-21-09(M)(3)(b): Such records shall includeincluding the following: (changed to "including")

New restriction: OAC 3745-21-29(I)(3): The owner or operator of a coating operation that is subject to this rule, is located in Butler, Clermont, Hamilton

or Warren county, and has an initial startup of the coating operation before the effective date of this rule shall notify the appropriate Ohio EPA district office or local air agency in writing that the coating operation is subject to this rule not later than sixty days after the effective date of this rule, providing the information specified in paragraph (I)(5) of this rule.

Removed restriction 1: OAC 3745-21-09(N)(3): Paragraphs (N)(1) and (N)(2) of this rule shall not apply to the following: (changed "shall" to "do")

Removed restriction 2: OAC 3745-21-09(O)(5): Any owner or operator of a solvent metal cleaning operation shall maintain records of the following information in a readily accessible location for at least five years and shall make these records available (removed shall)

New restriction: OAC 3745-21-29(I)(4): The owner or operator of a coating operation that is subject to this rule, is located in Butler, Clermont, Hamilton or Warren county, and has an initial startup of the coating operation on or after the effective date of this rule shall notify the appropriate Ohio EPA district office or local air agency in writing that the coating operation is subject to this rule not later than either the date of initial startup of the the subject coating operation or sixty days after the effective date of this rule (whichever is later), providing the information specified in paragraph (I)(5) of this rule.

Removed restriction 1: OAC 3745-21-09(O)(6)(a): Paragraph (O)(2)(d)(v) of this rule shall not apply to (changed "shall" to "does")

Removed restriction 2: OAC 3745-21-09(O)(6)(b): paragraphs (O)(2) to (O)(5) of this rule shall not apply to (changed "shall" to "do")

B. How many existing regulatory restrictions do you propose removing? 5

Removed restriction: OAC 3745-21-29(I)(5): The owner or operator of a coating operation that is subject to this rule with an initial startup date before May 12, 2011 shall notify the Ohio EPA district office or local air agency in writing that the coating operation is subject to this rule. (moved)

Removed restriction: OAC 3745-21-29(I)(5): The notification, which shall be submitted not later than July 11, 2011 (or within sixty days after the coating operation becomes subject to this rule), (moved)

Removed restriction: OAC 3745-21-29(I)(2): The owner or operator of a coating operation that is subject to this rule with an initial startup date on or after May

12, 2011 shall notify the Ohio EPA district office or local air agency in writing that the coating operation is subject to this rule. (moved)

Removed restriction: OAC 3745-21-29(I)(2): The notification, which shall be submitted not later than either the date of initial startup of the subject coating operation, or July 11, 2011 (whichever is later) (moved)

Removed restriction: OAC 3745-21-29(I)(2): shall provide the information listed under paragraph (I)(1) of this rule. (moved)

Rule Summary and Fiscal Analysis

Part B - Local Governments Questions

1. Does the rule increase costs for:

A. Public School Districts	No
B. County Government	Yes
C. Township Government	Yes
D. City and Village Governments	Yes

2. Please estimate the total cost, in dollars, of compliance with the rule for the affected local government(s). If you cannot give a dollar cost, explain how the local government is financially impacted.

OAC Chapter 3745-21 has been in the OAC since 1972. The rules have evolved over the years to address requirements in the Clean Air Act to develop regulations as part of an effort to achieve the NAAQS for CO and ozone within the state. These rules and additional technical support were submitted to U.S. EPA for review and approval as part of the SIP.

This Chapter has been modified over the years to incorporate requirements for categories of sources for which U.S. EPA has indicated that RACT should apply. In general, the levels of control that are available have been evaluated and presented in a series of CTGs issued by U.S. EPA. There are also rules based on information provided by U.S. EPA for other sources which were identified as non-CTG RACT.

Given the many and varied types of processes that are regulated under OAC chapter 3745-21, it is difficult to give an exact cost of compliance with the rules in this chapter in a limited space. The cost of compliance with these rules can range from zero cost for a control technology such as a work practice or raw material change, to a few million dollars for the installation and operation of a mechanical control device. As part of the permitting process, facilities can perform a RACT analysis which allows them to determine, based on all technologies available, the best and most cost-effective control strategy for their facility.

This rule has been in effect for several years. Most of the costs associated with compliance with the existing requirements of this rule have been addressed in previous rulemakings and have been well established in the industry. There may be some additional cost of compliance related to the expansion of the requirements in the

Cincinnati ozone nonattainment area in order to meet mandatory RACT requirements; however, many of the facilities affected by this expansion may already meet the requirements and not incur additional costs.

It should be noted that CTG based rules similar to Ohio's rules can also be found in Ohio's neighbor states and in any state containing a moderate ozone non-attainment area. Facilities wishing to locate in these types of areas will need to meet these requirements in all states.

3. **Is this rule the result of a federal government requirement? Yes**
 - A. **If yes, does this rule do more than the federal government requires? No**
 - B. **If yes, what are the costs, in dollars, to the local government for the regulation that exceeds the federal government requirement?**

Not Applicable

4. **Please provide an estimated cost of compliance for the proposed rule if it has an impact on the following:**
 - A. **Personnel Costs**

See above.
 - B. **New Equipment or Other Capital Costs**

See above.
 - C. **Operating Costs**

See above.
 - D. **Any Indirect Central Service Costs**

See above.
 - E. **Other Costs**

See above.

5. **Please explain how the local government(s) will be able to pay for the increased costs associated with the rule.**

Ohio EPA acknowledges that there will be an increase in costs associated with the expansion of the requirements in the Cincinnati ozone nonattainment area in order

to meet mandatory RACT requirements; however, many of the facilities affected by this expansion may already meet the requirements and not incur additional costs. Facilities that are affected will need to adjust their operational and maintenance budgets accordingly. These budgets are typically financed through a general fund.

6. What will be the impact on economic development, if any, as the result of this rule?

These rules are being promulgated to implement federal requirements for the application of reasonably available control technology to source categories of VOC in moderate ozone non-attainment areas. Rules governing VOC for these source types are in effect in many places around the country, and are not unique to the area covered by this rule. Therefore, any potential economic impact in the affected area would be minimal.

Reducing emissions benefits the affected area by providing a cost savings and economic benefit to stakeholders through reduced pollution. Not only does reducing pollution provide for better enjoyment of the states resources through cleaner air but also reduces property damage caused by pollution, reduces illnesses and reduces healthcare costs. The cost benefits, although difficult to quantify, are significant and may exceed the cost incurred by regulated entities required to comply with VOC RACT rules.

Rule Summary and Fiscal Analysis

Part C - Environmental Rule Questions

Pursuant to Am. Sub. H.B. 106 of the 121st General Assembly, prior to adopting a rule or an amendment to a rule dealing with environmental protection, or containing a component dealing with environmental protection, a state agency shall:

- (1) Consult with organizations that represent political subdivisions, environmental interests, business interests, and other persons affected by the proposed rule or amendment.
- (2) Consider documentation relevant to the need for, the environmental benefits or consequences of, other benefits of, and the technological feasibility of the proposed rule or rule amendment.
- (3) Specifically identify whether the proposed rule or rule amendment is being adopted or amended to enable the state to obtain or maintain approval to administer and enforce a federal environmental law or to participate in a federal environmental program, whether the proposed rule or rule amendment is more stringent than its federal counterpart, and, if the proposed rule or rule amendment is more stringent, the rationale for not incorporating its federal counterpart.
- (4) Include with the proposed rule or rule amendment and rule summary and fiscal analysis required to be filed with the Joint Committee on Agency Rule Review information relevant to the previously listed requirements.

(A) Were organizations that represent political subdivisions, environmental interests, business interests, and other persons affected by the proposed rule or amendment consulted? Yes

Please list each contact.

A draft of these rules was released for a 30-day public comment and review period ending June 18, 2021. The rules were released to Ohio EPA's electronic interested parties list, posted on Ohio EPA's regulations website and shared with interested industry parties. Several comments were received on Ohio EPA's rulemaking effort. Ohio EPA's response to comments document can be provided upon request. A copy of Ohio EPA's interested parties distribution list can be made available upon request.

(B) Was documentation that is relevant to the need for, the environmental benefits or consequences of, other benefits of, and the technological feasibility of the proposed rule or amendment considered? Yes

Please list the information provided and attach a copy of each piece of documentation to this form. (A SUMMARY OR INDEX MAY BE ATTACHED IN LIEU OF THE ACTUAL DOCUMENTATION.)

Clean Air Act, USEPA Control Technique Guidance Documents, LSC Style and Formatting Manual, and comments from interested parties.

- (C) **Is the proposed rule or rule amendment being adopted or amended to enable the state to obtain or maintain approval to administer and enforce a federal environmental law or to participate in a federal environmental program? Yes**

Is the proposed rule or rule amendment more stringent than its federal counterpart?
No Not Applicable

- (D) **If this is a rule amendment that is being adopted under a state statute that establishes standards with which the amendment is to comply, is the proposed rule amendment more stringent than the rule that it is proposing to amend? No**

Rule Summary and Fiscal Analysis

Part A - General Questions

Rule Number: 3745-21-09

Rule Type: Amendment

Rule Title/Tagline: Control of emissions of volatile organic compounds from stationary sources and perchloroethylene from dry cleaning facilities.

Agency Name: Ohio Environmental Protection Agency

Division:

Address: 50 West Town Street, Suite 700 PO Box 1049 Columbus OH 43216-1049

Contact: Holly Kaloz **Phone:** 614-644-2760

Email: holly.kaloz@epa.ohio.gov

I. Rule Summary

1. **Is this a five year rule review?** Yes
 - A. **What is the rule's five year review date?** 11/29/2021
2. **Is this rule the result of recent legislation?** No
3. **What statute is this rule being promulgated under?** 119.03
4. **What statute(s) grant rule writing authority?** 3704.03(E)
5. **What statute(s) does the rule implement or amplify?** 3704.03(A), 3704.03(E)
6. **What are the reasons for proposing the rule?**

This rule is being filed to fulfill the requirements of ORC 106.03 (5-yr review) and to adopt mandatory Reasonably Available Control Technology (RACT) requirements for the Cincinnati and Cleveland 2015 ozone nonattainment areas.

7. **Summarize the rule's content, and if this is an amended rule, also summarize the rule's changes.**

This rule identifies VOC emission and control requirements for several source categories that emit VOC. Amendments pursuant to the 5-year review are being

made to correct formatting to meet LSC requirements, to update facility names and addresses, to remove permanently closed facilities, and to remove unnecessary restriction language from the rule. In addition, amendments are being made to expand RACT requirements to the Cincinnati nonattainment area.

8. **Does the rule incorporate material by reference? Yes**
9. **If the rule incorporates material by reference and the agency claims the material is exempt pursuant to R.C. 121.75, please explain the basis for the exemption and how an individual can find the referenced material.**

This rule contains references to the Ohio Administrative Code (OAC). While copies of these rules and statutes are generally available to the public through libraries and on-line sources, including the Ohio EPA website, ORC 121.76 (A) exempts such references from the provisions of ORC 121.71 through 121.75.

This rule also contains references to the Code of Federal Regulations (CFR). These rules are generally available through libraries, Ohio EPA and U.S. EPA websites. CFR references have also been dated to reference the specific version of the rules. ORC 121.75 (D) exempts such references from the requirements of ORC 121.71 through 121.74.

This rule also contains references to the United States Code (USC), the Federal Insecticide, Rodenticide, and Fungicide Act, and the Clean Air Act. These rules and Acts are generally available through libraries, Ohio EPA and Government Printing Office's websites. USC references have also been dated to reference the specific version of the rules. ORC 121.75(D) exempts such references from the requirements of ORC 121.71 through 121.74.

The rule also contains references to analytical test methods used to determine parameters for materials subject to this rule or other materials utilized by regulators and impacted parties to determine or achieve compliance with these rules. These test methods and materials are commonly known and utilized by laboratories performing this type of analytical work. Copies of these test methods are available in libraries and the websites of the method's supporting organization (ASTM, ANSI, NFPA, NACE, etc.).

Referenced materials are cited, dated and availability noted in paragraph (JJ) of rule 3745-21-01 of the Administrative Code.

10. **If revising or re-filing the rule, please indicate the changes made in the revised or re-filed version of the rule.**

Refile: Ohio EPA has identified necessary clarifications and made revisions to OAC 3745-21-09, specifically, paragraphs (A)(1), (A)(3)(a), (A)(6), (A)(7), (C). These revisions clarify applicability for sources that will become subject to a new provision that supersedes an existing requirement. These revisions were identified during our internal review and are not the result of external comments.

II. Fiscal Analysis

11. Please estimate the increase / decrease in the agency's revenues or expenditures in the current biennium due to this rule.

This will have no impact on revenues or expenditures.

0.00

Not Applicable

12. What are the estimated costs of compliance for all persons and/or organizations directly affected by the rule?

OAC Chapter 3745-21 has been in the OAC since 1972. The rules have evolved over the years to address requirements in the Clean Air Act to develop regulations as part of an effort to achieve the NAAQS for CO and ozone within the state. These rules and additional technical support were submitted to U.S. EPA for review and approval as part of the SIP.

This Chapter has been modified over the years to incorporate requirements for categories of sources for which U.S. EPA has indicated that RACT should apply. In general, the levels of control that are available have been evaluated and presented in a series of CTGs issued by U.S. EPA. There are also rules based on information provided by U.S. EPA for other sources which were identified as non-CTG RACT.

Given the many and varied types of processes that are regulated under OAC chapter 3745-21, it is difficult to give an exact cost of compliance with the rules in this chapter in a limited space. The cost of compliance with these rules can range from zero cost for a control technology such as a work practice or raw material change, to a few million dollars for the installation and operation of a mechanical control device. As part of the permitting process, facilities can perform a RACT analysis which allows them to determine, based on all technologies available, the best and most cost-effective control strategy for their facility.

This rule has been in effect for several years. Most of the costs associated with compliance with the existing requirements of this rule have been addressed in previous rulemakings and have been well established in the industry. There may be some additional cost of compliance related to the expansion of the requirements in the Cincinnati ozone nonattainment area in order to meet mandatory RACT requirements; however, many of the facilities affected by this expansion may already meet the requirements and not incur additional costs.

It should be noted that CTG based rules similar to Ohio's rules can also be found in Ohio's neighbor states and in any state containing a moderate ozone non-attainment area. Facilities wishing to locate in these types of areas will need to meet these requirements in all states.

13. **Does the rule increase local government costs? (If yes, you must complete an RSFA Part B). Yes**
14. **Does the rule regulate environmental protection? (If yes, you must complete an RSFA Part C). Yes**
15. **If the rule imposes a regulation fee, explain how the fee directly relates to your agency's cost in regulating the individual or business.**

Not Applicable

III. Common Sense Initiative (CSI) Questions

16. **Was this rule filed with the Common Sense Initiative Office? Yes**
17. **Does this rule have an adverse impact on business? Yes**
 - A. **Does this rule require a license, permit, or any other prior authorization to engage in or operate a line of business? No**
 - B. **Does this rule impose a criminal penalty, a civil penalty, or another sanction, or create a cause of action, for failure to comply with its terms? No**
 - C. **Does this rule require specific expenditures or the report of information as a condition of compliance? Yes**

The rule requires periodic submission of reports that typically include deviations from requirements and exceedances of emissions limits. These costs are discussed in the fiscal analysis for this rule.

- D. Is it likely that the rule will directly reduce the revenue or increase the expenses of the lines of business of which it will apply or applies? No

IV. Regulatory Restrictions (This section only applies to agencies indicated in R.C. 121.95 (A))

18. Are you adding a new or removing an existing regulatory restriction as defined in R.C. 121.95? Yes

- A. How many new regulatory restrictions do you propose adding? 1

New restriction: OAC 3745-21-09(EEE): Portable oil and gas sources. Portable oil and gas sources relocating to Butler, Clermont, Cuyahoga, Geauga, Hamilton, Lake, Lorain, Medina, Portage, or Summit or Warren county may be subject to the USEPA CTG "Control Techniques Guidelines for the Oil and Natural Gas Industry". Sources subject to the requirements of this CTG shall submit an application for a federally enforceable installation permit in accordance with Chapter 3745-31 of the Administrative Code to incorporate applicable requirements of the CTG into a federally enforceable permit prior to relocation.

Removed restriction 1: OAC 3745-21-01(W): Except as otherwise provided in this paragraph, the definitions in rule 3745-15-01 of the Administrative Code and paragraph (B) of this rule shall apply to rule 3745-21-14 (removed shall)

Removed restriction 2: OAC 3745-21-01(W)(4): Irrespective of the product being produced, a batch process train which is independent of other processes shall be considered a single batch process train for purposes of this rule. (changed "shall be" to "is")

- B. How many existing regulatory restrictions do you propose removing? 107

Removed restriction: OAC 3745-21-09(B)(3)(c): A copy of such record shall be sent to the director within forty-five days after the exceedance occurs. (deleted sentence; added deadline to previous sentence)

Removed restriction: OAC 3745-21-09(B)(3)(e): A copy of such record shall be sent to the director within forty-five days after the exceedance occurs. (deleted sentence; added deadline to previous sentence)

Removed restriction: OAC 3745-21-09(B)(3)(g): A copy of such record shall be sent to the director within thirty days after the exceedance occurs. (deleted sentence; added deadline to previous sentence)

Removed restriction: OAC 3745-21-09(B)(3)(i): A copy of such record shall be sent to the director within forty-five days after the exceedance occurs. (deleted sentence; added deadline to previous sentence)

Removed restriction: OAC 3745-21-09(B)(3)(k): A copy of such record shall be sent to the director within forty-five days after the exceedance occurs. (deleted sentence; added deadline to previous sentence)

Removed restriction: OAC 3745-21-09(B)(3)(m): These quarterly reports shall be submitted by April thirtieth, July thirty-first, October thirty-first, and January thirty-first, and shall cover the records for the previous calendar quarters. (deleted sentence; added deadlines to previous sentence)

Removed restriction: OAC 3745-21-09(B)(4)(c): These quarterly reports shall be submitted by April thirtieth, July thirty-first, October thirty-first, and January thirty-first, and shall cover the records for the previous calendar quarters. (deleted sentence; added deadlines to previous sentence)

Removed restriction: OAC 3745-21-09(B)(4)(d): The continuous monitoring and recording devices shall be installed and placed in operation either within one hundred eighty days of March 31, 1993 or by the date of operation of any new control equipment installed for the source after March 31, 1993 to achieve compliance with the VOC control requirements of this rule. (deleted sentence; added deadlines to previous sentence)

Removed restriction: OAC 3745-21-09(B)(5): the alternative recordkeeping and reporting program shall supersede paragraph (B)(3) or (B)(4) of this rule and shall be specified in the terms and conditions of the permit (removed shall)

Removed restriction: OAC 3745-21-09(B)(5): Any alternative recordkeeping and reporting program approved by the director shall also be approved by the USEPA as a revision to the state implementation plan. (deleted sentence; added "and USEPA as a revision to the state implementation plan" to previous sentence)

Removed restriction: OAC 3745-21-09(C): For any source located in Ashtabula, Cuyahoga, Geauga, Lake, Lorain, Medina, Portage, or Summit county subject to paragraph (C) of this rule, the requirement to comply with paragraph (C) of this

rule shall terminate at such time the source becomes subject to and complies with rule 3745-21-29 of the Administrative Code. (changed "shall terminate" to "terminates")

Removed restriction: OAC 3745-21-09(C)(1)(a)(ii): RT shall be calculated as follows: (changed "shall be" to "is")

Removed restriction: OAC 3745-21-09(C)(5)(b): A copy of such monthly record shall be sent to the director within thirty days following the end of the calendar month. (deleted sentence; added deadline to previous sentence)

Removed restriction: OAC 3745-21-09(C)(7)(b): A copy of such monthly record shall be sent to the director within thirty days following the end of the calendar month. (deleted sentence; added deadline to previous sentence)

Removed restriction: OAC 3745-21-09(C)(8)(d): The calculated, controlled VOC emission rate, in mass of VOC per unit volume of coating solids, as applied. The controlled VOC emission rate shall be: (changed to "The calculated, controlled VOC emission rate, in mass of VOC per unit volume of coating solids, as applied, calculated using the following:")

Removed restriction: OAC 3745-21-09(C)(9): A copy of such monthly record shall be sent to the director within thirty days following the end of the calendar month. (deleted sentence; added deadline to previous sentence)

Removed restriction: OAC 3745-21-09(H)(3): Paragraphs (H)(1) and (H)(2) of this rule shall not apply to the application of organisol or plastisol coatings. (changed to "The application of organisol or plastisol coatings are exempt from paragraphs (H)(1) and (H)(2) of this rule.")

Removed restriction: OAC 3745-21-09(I)(4)(b)(iii): Paragraphs (I)(4)(a) and (I)(4)(d) of this rule shall not apply to the following: (changed "shall not apply" to "are not applicable")

Removed restriction: OAC 3745-21-09(K)(2): The emission limit under paragraph (K)(1) of this rule shall not apply to..." (changed "shall" to "does")

Removed restriction: OAC 3745-21-09(K)(4): The emission limit under paragraph (K)(1) of this rule shall not apply to..." (changed "shall" to "does")

Removed restriction: OAC 3745-21-09(K)(5): The emission limit under paragraph (K)(1) of this rule shall not apply to..." (changed "shall" to "does")

Removed restriction: OAC 3745-21-09(K)(6)(b)(ii): Paragraphs (K)(6)(a) and (K)(6)(e) of this rule shall not apply to the following: (changed "shall" to "do")

Removed restriction: OAC 3745-21-09(L)(3): Any owner or operator of a fixed roof tank that is not exempted pursuant to paragraph (L)(2) of this rule shall maintain records of the following information in a readily accessible location for at least five years and shall make copies of the records (removed shall)

Removed restriction: OAC 3745-21-09(M)(3)(b): Such records shall includeincluding the following: (changed to "including")

Removed restriction: OAC 3745-21-09(N)(3): Paragraphs (N)(1) and (N)(2) of this rule shall not apply to the following: (changed "shall" to "do")

Removed restriction: OAC 3745-21-09(O)(5): Any owner or operator of a solvent metal cleaning operation shall maintain records of the following information in a readily accessible location for at least five years and shall make these records available..." (removed shall)

Removed restriction: OAC 3745-21-09(O)(6)(a): Paragraph (O)(2)(d)(v) of this rule shall not apply to(changed "shall" to "does")

Removed restriction: OAC 3745-21-09(O)(6)(b): paragraphs (O)(2) to (O)(5) of this rule shall not apply to(changed "shall" to "do")

Removed restriction: OAC 3745-21-09(O)(6)(d): Such documentation shall be provided to the appropriate Ohio EPA district office or local air agency. (changed "such documentation shall" to "and documentation is")

Removed restriction: OAC 3745-21-09(P)(2): the following operating practices shall be followed (changed "shall be followed" to "are applicable")

Removed restriction: OAC 3745-21-09(P)(2)(a): The vapor balance system shall be kept in good working order and shall be used at all times during the transfer of gasoline. (removed shall be)

Removed restriction: OAC 3745-21-09(P)(5)(a): Paragraphs (P)(1) to (P)(4) of this rule shall not apply (changed "shall not apply" to "are not applicable")

Removed restriction: OAC 3745-21-09(P)(5)(b): Paragraph (P)(1)(b) of this rule shall not apply (changed "shall not apply" to "is not applicable")

Removed restriction: OAC 3745-21-09(P)(6): Any owner or operator of a bulk gasoline plant shall maintain records of the following information in a readily accessible location for at least five years and shall immediately make these records available (removed shall)

Removed restriction: OAC 3745-21-09(Q)(4): Paragraph (Q)(1) of this rule shall not apply to (changed "shall" to "does")

Removed restriction: OAC 3745-21-09(R)(2): the following operating practices shall be followed (changed "shall be followed" to "are applicable")

Removed restriction: OAC 3745-21-09(R)(2)(a): The vapor balance system shall be kept in good working order and shall be used at all times during the transfer of gasoline. (changed to "A vapor balance system kept in good working order and used at all times during the transfer of gasoline.")

Removed restriction: OAC 3745-21-09(R)(2)(b): There shall be no leaks in the delivery vessel pressure/vacuum relief valves and hatch covers. (changed to "Secure delivery vessel pressure/vacuum relief valves and hatch covers which do not leak.")

Removed restriction: OAC 3745-21-09(R)(2)(c): There shall be no leaks in the vapor and liquid lines during the transfer of gasoline. (changed to "Secure vapor and liquid lines which do not leak during the transfer of gasoline.")

Removed restriction: OAC 3745-21-09(R)(4): Paragraphs (R)(1) to (R)(3) of this rule shall not apply to the following: (changed "shall" to "do")

Removed restriction: OAC 3745-21-09(R)(5): The records shall be maintained at the facility for a period of three years. (removed shall and moved to list form following)

Removed restriction: OAC 3745-21-09(R)(5): The owner or operator shall notify the director if the annual gasoline throughput for any rolling twelve-month period is equal to or greater than one hundred twenty thousand gallons. (removed shall and moved to list form following)

Removed restriction: OAC 3745-21-09(R)(5): The director shall be notified within forty-five days after the exceedance occurs. (removed shall and moved to list form following)

Removed restriction: OAC 3745-21-09(T)(1)(e): The tag shall be readily visible and weatherproof (removed shall and moved to list form following)

Removed restriction: OAC 3745-21-09(T)(1)(e): it shall bear an identification number (removed shall and moved to list form following)

Removed restriction: OAC 3745-21-09(T)(1)(e): and it shall clearly indicate the date the leak was detected (removed shall and moved to list form following)

Removed restriction: OAC 3745-21-09(T)(1)(e): The tag shall remain in place until the leaking component is repaired. (removed shall and moved to list form following)

Removed restriction: OAC 3745-21-09(T)(1)(f): The monitoring log shall contain (changed to "containing")

Removed restriction: OAC 3745-21-09(T)(4): "...shall be acceptable to the director." (changed "shall be" to "is")

Removed restriction: OAC 3745-21-09(U)(1): the limit which is least restrictive shall apply (changed "shall apply" to "applies")

Removed restriction: OAC 3745-21-09(U)(2): Paragraph (U)(1) of this rule shall not apply (changed "shall not apply" to "is not applicable")

Removed restriction: OAC 3745-21-09(U)(2)(e)(iii): paragraphs (U)(2)(e)(i) to (U)(2)(e)(iii) of this rule shall not apply (changed "shall not apply" to "is not applicable")

Removed restriction: OAC 3745-21-09(U)(2)(f)(ii): "... The alternative limitation shall be..." (changed to " provided the alternative limit is")

Removed restriction: OAC 3745-21-09(U)(2)(f)(ii): The alternative limitation shall be an emissions rate (e.g., pounds VOC per gallon) or overall per cent reduction but shall not be in terms of mass per time (e.g., pounds per hour). (changed to "and is expressed as an emissions rate (e.g., pounds VOC per gallon) or overall per cent reduction but not in terms of mass per time (e.g., pounds per hour).")

Removed restriction: OAC 3745-21-09(U)(2)(f)(iii): The installation permit shall contain..." (changed to "containing")

Removed restriction: OAC 3745-21-09(U)(2)(h): (pounds of VOC attributed to metal parts or products coating lines in which non-metal parts or products were being coated shall not count towards (changed "shall not count" to "is exempt from counting"))

Removed restriction: OAC 3745-21-09(V)(1)(h): the gasoline tank truck shall also be inspected/repared in accordance with the following procedures (changed to "the following inspection and repair procedures apply")

Removed restriction: OAC 3745-21-09(X)(2): Paragraph (X)(1) of this rule shall not apply to the following operations: (changed to "The following operations are exempt from the requirements of paragraph Paragraph (X)(1) of this rule")

Removed restriction: OAC 3745-21-09(Y)(2): Paragraph (Y)(1) of this rule shall not apply (changed "shall not apply" to "is not applicable")

Removed restriction: OAC 3745-21-09(Z)(3): The following external floating roof tanks shall be exempted (changed "shall be" to "are")

Removed restriction: OAC 3745-21-09(Z)(4): and shall make copies of the records available (removed shall)

Removed restriction: OAC 3745-21-09(AA)(2)(a): Paragraphs (AA)(1)(a) to (AA)(1)(e) of this rule shall not apply (changed "shall not apply" to "are not applicable")

Removed restriction: OAC 3745-21-09(AA)(2)(b): Paragraph (AA)(1)(a) of this rule shall not apply (changed "shall not apply" to "is not applicable")

Removed restriction: OAC 3745-21-09(AA)(2)(c): Paragraph (AA)(1)(a) of this rule shall not apply (changed "shall not apply" to "is not applicable")

Removed restriction: OAC 3745-21-09(AA)(4): and shall make these records available (removed shall)

Removed restriction: OAC 3745-21-09(BB)(1)(e): The leak shall be repaired (changed "The leak shall be" to "and the leak")

Removed restriction: OAC 3745-21-09(BB)(3): Paragraphs (BB)(1)(a), (BB)(1)(b), and (BB)(2) of this rule shall not apply (changed "shall" to "do")

Removed restriction: OAC 3745-21-09(BB)(4)(a): and shall make these records available (removed shall)

Removed restriction: OAC 3745-21-09(BB)(4)(b): and shall make these records available (removed shall)

Removed restriction: OAC 3745-21-09(DD)(2)(b)(i): Any pump in light liquid service shall be monitored monthly. (changed to "Monthly for any pump in light liquid service.")

Removed restriction: OAC 3745-21-09(DD)(2)(b)(ii): Any valve in gas/vapor service or in light liquid service shall be monitored monthly (changed to "Monthly for any valve in gas/vapor service or in light liquid service")

Removed restriction: OAC 3745-21-09(DD)(2)(b)(ii): The quarterly monitoring shall begin (changed to "beginning")

Removed restriction: OAC 3745-21-09(DD)(2)(b)(ii): and shall be conducted in the first month of each calendar quarter (removed "shall be")

Removed restriction: OAC 3745-21-09(DD)(2)(j): and the first attempts at repair shall include (changed to "including")

Removed restriction: OAC 3745-21-09(DD)(2)(m): and shall include the following information (removed shall)

Removed restriction: OAC 3745-21-09(DD)(8)(c): The barrier fluid system shall be in heavy liquid service or shall not be in VOC service. (removed shall)

Removed restriction: OAC 3745-21-09(DD)(10)(d)(i): The flare shall be designed (changed to "Designed")

Removed restriction: OAC 3745-21-09(DD)(10)(d)(ii): The flare shall be operated (changed to "Operated")

Removed restriction: OAC 3745-21-09(DD)(10)(d)(ii): and shall be monitored with a thermocouple (removed shall)

Removed restriction: OAC 3745-21-09(DD)(10)(d)(ii): and shall be monitored to detect any failure (removed shall)

Removed restriction: OAC 3745-21-09(DD)(10)(d)(iii): The flare shall be (changed to "Be")

Removed restriction: OAC 3745-21-09(DD)(10)(d)(iv): or shall be two hundred Btu/scf or greater (removed "shall be")

Removed restriction: OAC 3745-21-09(DD)(10)(d)(v): the flare shall be designed and operated (removed "the flare shall")

Removed restriction: OAC 3745-21-09(DD)(10)(d)(vi)(a): shall be greater than one thousand Btu/scf (changed "shall be" to "is")

Removed restriction: OAC 3745-21-09(DD)(10)(d)(vi)(b): The flare shall be designed and operated (changed "shall be" to "is")

Removed restriction: OAC 3745-21-09(DD)(11)(b): A delay of repair shall be allowed if the repair is technically infeasible without a process unit shutdown. However, the repair shall occur before the end of the next process unit shutdown. (changed to "If the repair is technically infeasible without a process unit shutdown providing the repair occurs before the end of the next process unit shutdown.")

Removed restriction: OAC 3745-21-09(DD)(11)(c): A delay of repair shall be allowed for a piece of equipment that is (changed to "For a piece of equipment that is")

Removed restriction: OAC 3745-21-09(DD)(11)(d): A delay of repair for a valve shall be allowed if the following occurs: (changed to "For a valve shall be allowed if the following occurs:")

Removed restriction: OAC 3745-21-09(DD)(11)(e): A delay of repair for For a pump shall be allowed if the following occurs: (changed to "For a pump shall be allowed if the following occurs:")

Removed restriction: OAC 3745-21-09(DD)(11)(f): A delay of repair beyond a process unit shutdown shall be allowed for a valve if (changed to "Beyond a process unit shutdown for a valve provided")

Removed restriction: OAC 3745-21-09(DD)(13)(a): The alternative monitoring standard shall be based on maintaining the percentage of valves leaking at 2.0 or less. (removed sentence and added percentage to previous sentence)

Removed restriction: OAC 3745-21-09(DD)(13)(f)(i): All valves subject to this alternative monitoring standard shall be monitored..." (changed to "Monitor valves subject to "...this alternative monitoring standard..."")

Removed restriction: OAC 3745-21-09(DD)(13)(f)(iii): The percentage of valves leaking shall be determined... (changed to "Determine the percentage of valves leaking")

Removed restriction: OAC 3745-21-09(DD)(15)(b): The results of such compliance tests shall be reported (changed to "...and the results of such compliance tests reported")

Removed restriction: OAC 3745-21-09(DD)(15)(c): The semiannual reports shall be submitted by (changed to "...and submitted by")

Removed restriction: OAC 3745-21-09(DD)(15)(c): ...and shall include information for... (removed shall)

Removed restriction: OAC 3745-21-09(EE)(2)(a): "...shall be exempt from..." (changed "shall be" to "is")

Removed restriction: OAC 3745-21-09(EE)(2)(a): This exemption shall terminate (changed "shall terminate" to "terminates")

Removed restriction: OAC 3745-21-09(EE)(2)(b): shall be exempt from (changed "shall be" to "is")

Removed restriction: OAC 3745-21-09(EE)(2)(b): shall be based upon (changed "shall be" to "is")

Removed restriction: OAC 3745-21-09(FF): shall comply with the following (changed to "is subject to the following")

Removed restriction: OAC 3745-21-09(FF)(2): These records shall be maintained at the facility for a period of three years. (removed; added timeline to previous sentence)

Removed restriction: OAC 3745-21-09(FF)(2): A copy of the record showing the exceedance shall be submitted to the director within thirty days after the exceedance occurs. (removed; added deadline to previous sentence)

Removed restriction: OAC 3745-21-09(JJ): shall comply (changed to "is subject to")

Removed restriction: OAC 3745-21-09(KK): shall comply (changed to "is subject to")

Removed restriction: OAC 3745-21-09(LL): shall comply (changed to "is subject to")

Removed restriction: OAC 3745-21-09(MM)(1): The paint manufacturing operations shall include the following equipment for the processing or use of solvent based or waterbased paint materials: mixing tanks for paint liquids and pigments, grinding mills, paint thinning and tinting tanks, paint filling equipment for shipping containers, cleaning equipment for paint processing equipment, and recovery equipment for the cleaning solvents. The paint laboratory operations shall include the following equipment for the processing or use of solvent based or waterbased paint materials: paint spray booths and associated ovens within the paint manufacturing quality control laboratory and the paint research laboratory (removed; changed to list form)

Rule Summary and Fiscal Analysis

Part B - Local Governments Questions

1. Does the rule increase costs for:

A. Public School Districts	No
B. County Government	Yes
C. Township Government	Yes
D. City and Village Governments	Yes

2. Please estimate the total cost, in dollars, of compliance with the rule for the affected local government(s). If you cannot give a dollar cost, explain how the local government is financially impacted.

OAC Chapter 3745-21 has been in the OAC since 1972. The rules have evolved over the years to address requirements in the Clean Air Act to develop regulations as part of an effort to achieve the NAAQS for CO and ozone within the state. These rules and additional technical support were submitted to U.S. EPA for review and approval as part of the SIP.

This Chapter has been modified over the years to incorporate requirements for categories of sources for which U.S. EPA has indicated that RACT should apply. In general, the levels of control that are available have been evaluated and presented in a series of CTGs issued by U.S. EPA. There are also rules based on information provided by U.S. EPA for other sources which were identified as non-CTG RACT.

Given the many and varied types of processes that are regulated under OAC chapter 3745-21, it is difficult to give an exact cost of compliance with the rules in this chapter in a limited space. The cost of compliance with these rules can range from zero cost for a control technology such as a work practice or raw material change, to a few million dollars for the installation and operation of a mechanical control device. As part of the permitting process, facilities can perform a RACT analysis which allows them to determine, based on all technologies available, the best and most cost-effective control strategy for their facility.

This rule has been in effect for several years. Most of the costs associated with compliance with the existing requirements of this rule have been addressed in previous rulemakings and have been well established in the industry. There may be some additional cost of compliance related to the expansion of the requirements in the

Cincinnati ozone nonattainment area in order to meet mandatory RACT requirements; however, many of the facilities affected by this expansion may already meet the requirements and not incur additional costs.

It should be noted that CTG based rules similar to Ohio's rules can also be found in Ohio's neighbor states and in any state containing a moderate ozone non-attainment area. Facilities wishing to locate in these types of areas will need to meet these requirements in all states.

3. **Is this rule the result of a federal government requirement?** Yes
 - A. **If yes, does this rule do more than the federal government requires?** No
 - B. **If yes, what are the costs, in dollars, to the local government for the regulation that exceeds the federal government requirement?**

Not Applicable

4. **Please provide an estimated cost of compliance for the proposed rule if it has an impact on the following:**
 - A. **Personnel Costs**

See above.
 - B. **New Equipment or Other Capital Costs**

See above.
 - C. **Operating Costs**

See above.
 - D. **Any Indirect Central Service Costs**

See above.
 - E. **Other Costs**

See above.

5. **Please explain how the local government(s) will be able to pay for the increased costs associated with the rule.**

Ohio EPA acknowledges that there will be an increase in costs associated with the expansion of the requirements in the Cincinnati ozone nonattainment area in order to meet mandatory RACT requirements; however, many of the facilities affected by this expansion may already meet the requirements and not incur additional costs. Facilities that are affected will need to adjust their operational and maintenance budgets accordingly. These budgets are typically financed through a general fund.

6. What will be the impact on economic development, if any, as the result of this rule?

These rules are being promulgated to implement federal requirements for the application of reasonably available control technology to source categories of VOC in moderate ozone non-attainment areas. Rules governing VOC for these source types are in effect in many places around the country, and are not unique to the area covered by this rule. Therefore, any potential economic impact in the affected area would be minimal.

Reducing emissions benefits the affected area by providing a cost savings and economic benefit to stakeholders through reduced pollution. Not only does reducing pollution provide for better enjoyment of the states resources through cleaner air but also reduces property damage caused by pollution, reduces illnesses and reduces healthcare costs. The cost benefits, although difficult to quantify, are significant and may exceed the cost incurred by regulated entities required to comply with VOC RACT rules.

Rule Summary and Fiscal Analysis

Part C - Environmental Rule Questions

Pursuant to Am. Sub. H.B. 106 of the 121st General Assembly, prior to adopting a rule or an amendment to a rule dealing with environmental protection, or containing a component dealing with environmental protection, a state agency shall:

- (1) Consult with organizations that represent political subdivisions, environmental interests, business interests, and other persons affected by the proposed rule or amendment.
- (2) Consider documentation relevant to the need for, the environmental benefits or consequences of, other benefits of, and the technological feasibility of the proposed rule or rule amendment.
- (3) Specifically identify whether the proposed rule or rule amendment is being adopted or amended to enable the state to obtain or maintain approval to administer and enforce a federal environmental law or to participate in a federal environmental program, whether the proposed rule or rule amendment is more stringent than its federal counterpart, and, if the proposed rule or rule amendment is more stringent, the rationale for not incorporating its federal counterpart.
- (4) Include with the proposed rule or rule amendment and rule summary and fiscal analysis required to be filed with the Joint Committee on Agency Rule Review information relevant to the previously listed requirements.

(A) Were organizations that represent political subdivisions, environmental interests, business interests, and other persons affected by the proposed rule or amendment consulted? Yes

Please list each contact.

A draft of these rules was released for a 30-day public comment and review period ending June 18, 2021. The rules were released to Ohio EPA's electronic interested parties list, posted on Ohio EPA's regulations website and shared with interested industry parties. Several comments were received on Ohio EPA's rulemaking effort. Ohio EPA's response to comments document can be provided upon request. A copy of Ohio EPA's interested parties distribution list can be made available upon request.

(B) Was documentation that is relevant to the need for, the environmental benefits or consequences of, other benefits of, and the technological feasibility of the proposed rule or amendment considered? Yes

Please list the information provided and attach a copy of each piece of documentation to this form. (A SUMMARY OR INDEX MAY BE ATTACHED IN LIEU OF THE ACTUAL DOCUMENTATION.)

Clean Air Act, USEPA Control Technique Guidance Documents, LSC Style and Formatting Manual, and comments from interested parties.

- (C) **Is the proposed rule or rule amendment being adopted or amended to enable the state to obtain or maintain approval to administer and enforce a federal environmental law or to participate in a federal environmental program? Yes**

Is the proposed rule or rule amendment more stringent than its federal counterpart?
No Not Applicable

- (D) **If this is a rule amendment that is being adopted under a state statute that establishes standards with which the amendment is to comply, is the proposed rule amendment more stringent than the rule that it is proposing to amend? No**

Article III
Attachment D
JCARR Agenda

JOINT COMMITTEE ON AGENCY RULE REVIEW
Agenda - 1/25/2022 - 11:00 AM
Senate Finance Hearing Room (Finan Hearing Room)



FINAL REGULAR AGENDA

FINAL REGULAR AGENDA

1 Architects Board •

Total Rules: 18 Original Filing Date: 11/30/2021

Jurisdiction Ends: 2/3/2022

Public Hearing: 1/4/2022

<u>Rule Type</u>	<u>Action</u>	<u>CSI</u>	<u>FYR</u>	<u>Rule Number</u>	<u>Rule Title</u>
Amendment	Original Filing	Yes	Yes	4703-1-01	Definitions.
Amendment	Original Filing	Yes	Yes	4703-1-02	Applications.
Amendment	Original Filing	Yes	Yes	4703-1-03	Certificates.
Amendment	Original Filing	Yes	Yes	4703-1-04	Fees.
Amendment	Original Filing	Yes	Yes	4703-2-01	Examination.
Rescission	Original Filing	Yes	Yes	4703-2-03	Educational requirements and credits.
New Rule	Original Filing	Yes	No	4703-2-03	Educational requirements and credits.
Amendment	Original Filing	Yes	Yes	4703-2-04	Training requirements.
Amendment	Original Filing	Yes	Yes	4703-2-05	Registration by reciprocity.
Amendment	Original Filing	Yes	Yes	4703-2-06	Program providing for reimbursement of IDP enrollment fees.
Amendment	Original Filing	Yes	Yes	4703-2-07	Continuing education.
Amendment	Original Filing	Yes	Yes	4703-2-08	Military provisions related to licensure.
Amendment	Original Filing	Yes	Yes	4703-3-01	Seal requirements.
Amendment	Original Filing	Yes	Yes	4703-3-02	Architectural firms.
Rescission	Original Filing	Yes	Yes	4703-3-04	Branch offices.
Amendment	Original Filing	Yes	Yes	4703-3-05	Interstate practice.
Amendment	Original Filing	Yes	Yes	4703-3-12	Design build.
Amendment	Original Filing	Yes	Yes	4703-3-13	Communication: prohibition of improper contacts.

2 Counselor, Social Worker, and Marriage and Family Therapist Board •

Total Rules: 25 Original Filing Date: 11/29/2021

Jurisdiction Ends: 2/2/2022

Public Hearing: 1/6/2022

<u>Rule Type</u>	<u>Action</u>	<u>CSI</u>	<u>FYR</u>	<u>Rule Number</u>	<u>Rule Title</u>
------------------	---------------	------------	------------	--------------------	-------------------

Click on the rule number in blue above to view the rule in its entirety on the *Register of Ohio* website.

Amendment	Original Filing	Yes	No	4757-1-04	Applications of first licensure.
Amendment	Original Filing	Yes	No	4757-1-07	Discipline actions that may include fines.
Amendment	Original Filing	No	No	4757-3-01	Definitions.
Amendment	Original Filing	Yes	No	4757-5-10	Standards of ethical practice and professional conduct: reporting unethical actions.
Amendment	Original Filing	No	Yes	4757-7-01	Renewal of license or certificate of registration.
Amendment	Original Filing	Yes	No	4757-9-05	Approval of continuing professional education programs required for renewal of licenses and certificates of registration issued by the board.
Amendment	Original Filing	No	No	4757-9-06	Sources of continuing professional education.
Amendment	Original Filing	No	No	4757-9-07	Documentation of continuing professional education required for renewal of a license or certificate of registration.
Amendment	Original Filing	No	Yes	4757-11-01	Denial, and disciplinary action for licenses or certificates of registration issued by the counselor, social worker, and marriage and family therapist board.
Amendment	Original Filing	No	No	4757-13-01	Education requirements for admission to the examination for licensed professional counselor.
Amendment	Original Filing	No	No	4757-13-04	Licensure and education requirements for admission of applicants holding a doctoral degree in counselor education to the examination for professional counselor, who do not meet the education requirements in rule 4757-13-01 of the Administrative Code.
Amendment	Original Filing	Yes	No	4757-13-05	Professional counselor and professional clinical counselor examination policy.
Amendment	Original Filing	Yes	Yes	4757-13-09	Counselor trainee registration.
New Rule	Original Filing	Yes	No	4757-13-10	Requirements for a Temporary Counselor License.
Amendment	Original Filing	Yes	No	4757-15-02	Scope of practice for a licensed professional clinical counselor.
Amendment	Original Filing	Yes	No	4757-17-01	Counseling supervision.
Amendment	Original Filing	Yes	No	4757-19-01	Requirements for licensure as a social worker.
Amendment	Original Filing	Yes	No	4757-19-03	Requirements for a certificate of registration as a social work assistant.
Amendment	Original Filing	Yes	No	4757-19-04	Social worker examination policy.
Amendment	Original Filing	Yes	Yes	4757-19-05	Social worker trainee applications.
Amendment	Original Filing	Yes	No	4757-19-06	Requirements for social work applicants wishing to obtain a temporary social work license.
Amendment	Original Filing	Yes	No	4757-21-02	Scope of practice for a social worker.
Amendment	Original Filing	Yes	No	4757-21-03	Scope of practice for an independent social worker.
Amendment	Original Filing	Yes	No	4757-25-03	General requirements for licensure as a marriage and family therapist.

Click on the rule number in blue above to view the rule in its entirety on the *Register of Ohio* website.

Amendment Original Filing Yes Yes [4757-25-08](#) Marriage and family therapist trainee registration.

3 Department of Administrative Services • Division of Human Resources

Total Rules: 3 Original Filing Date: 11/30/2021 Jurisdiction Ends: 2/3/2022 Public Hearing: 1/3/2022

<u>Rule Type</u>	<u>Action</u>	<u>CSI</u>	<u>FYR</u>	<u>Rule Number</u>	<u>Rule Title</u>
Amendment	Original Filing	No	No	123:1-32-01	Availability and charge of sick leave, vacation leave, and personal leave and compensation for sick leave of employees paid by warrant of the director of budget and management.
Amendment	Original Filing	No	No	123:1-46-03	Experimental leave and benefits program.
Amendment	Original Filing	No	No	123:1-71-03	Eligibility, contribution and withdrawal procedures.

4 Department of Aging •

Total Rules: 1 Original Filing Date: 10/4/2021 Date of Refiled Filing: 1/4/2022 Jurisdiction Ends: 2/3/2022 Public Hearing: 11/8/2021

<u>Rule Type</u>	<u>Action</u>	<u>CSI</u>	<u>FYR</u>	<u>Rule Number</u>	<u>Rule Title</u>
Amendment	Refiled Filing	No	Yes	173-14-14	Staffing requirements, staff qualifications, and background checks.

5 Department of Aging •

Total Rules: 1 Original Filing Date: 11/23/2021 Jurisdiction Ends: 1/27/2022 Public Hearing: 12/27/2021

<u>Rule Type</u>	<u>Action</u>	<u>CSI</u>	<u>FYR</u>	<u>Rule Number</u>	<u>Rule Title</u>
Amendment	Original Filing	Yes	Yes	173-14-28	Bed fee collection guidelines.

6 Department of Aging •

Total Rules: 2 Original Filing Date: 11/23/2021 Jurisdiction Ends: 1/27/2022 Public Hearing: 12/27/2021

<u>Rule Type</u>	<u>Action</u>	<u>CSI</u>	<u>FYR</u>	<u>Rule Number</u>	<u>Rule Title</u>
Amendment	Original Filing	No	Yes	173-38-01	Assisted living program (medicaid-funded component): introduction and definitions.
Amendment	Original Filing	No	Yes	173-38-03	Assisted living program (medicaid-funded component): enrollment and reassessment of individuals.

7 Department of Aging •

Total Rules: 1 Original Filing Date: 11/23/2021 Jurisdiction Ends: 1/27/2022 Public Hearing: 12/27/2021

<u>Rule Type</u>	<u>Action</u>	<u>CSI</u>	<u>FYR</u>	<u>Rule Number</u>	<u>Rule Title</u>
Amendment	Original Filing	No	Yes	173-42-06	PASSPORT program (medicaid-funded component): individuals' choices and responsibilities.

Total Rules: 1 Original Filing Date: 11/23/2021 Date of Revised Filing: 11/30/2021 Jurisdiction Ends: 1/27/2022 Public Hearing: 12/27/2021

<u>Rule Type</u>	<u>Action</u>	<u>CSI</u>	<u>FYR</u>	<u>Rule Number</u>	<u>Rule Title</u>
Amendment	Revised Filing	No	Yes	173-42-01	PASSPORT program (medicaid-funded component): introduction and definitions.

8 Department of Aging •

Total Rules: 2 Original Filing Date: 11/23/2021 Jurisdiction Ends: 1/27/2022 Public Hearing: 12/27/2021

<u>Rule Type</u>	<u>Action</u>	<u>CSI</u>	<u>FYR</u>	<u>Rule Number</u>	<u>Rule Title</u>
Amendment	Original Filing	No	Yes	173-50-03	PACE: enrollment, plan of care, and reassessment.
Amendment	Original Filing	No	Yes	173-50-04	PACE: voluntary disenrollment.
Total Rules: 1		Original Filing Date: 11/23/2021		Date of Refiled Filing: 1/4/2022	Jurisdiction Ends: 2/3/2022 Public Hearing: 12/27/2021

<u>Rule Type</u>	<u>Action</u>	<u>CSI</u>	<u>FYR</u>	<u>Rule Number</u>	<u>Rule Title</u>
Amendment	Refiled Filing	No	Yes	173-50-05	PACE: involuntary disenrollment.

9 Department of Aging •

Total Rules: 3 Original Filing Date: 11/30/2021 Jurisdiction Ends: 2/3/2022 Public Hearing:

<u>Rule Type</u>	<u>Action</u>	<u>CSI</u>	<u>FYR</u>	<u>Rule Number</u>	<u>Rule Title</u>
Amendment	Original Filing	No	Yes	173-40-01	PASSPORT program (state-funded component): introduction and definitions.
Amendment	Original Filing	No	Yes	173-40-02	PASSPORT program (state-funded component): individual eligibility requirements.
Amendment	Original Filing	No	Yes	173-40-03	PASSPORT program (state-funded component): individual disenrollment and other actions.

10 Department of Aging •

Total Rules: 3 Original Filing Date: 11/30/2021 Jurisdiction Ends: 2/3/2022 Public Hearing:

<u>Rule Type</u>	<u>Action</u>	<u>CSI</u>	<u>FYR</u>	<u>Rule Number</u>	<u>Rule Title</u>
Amendment	Original Filing	No	Yes	173-51-01	Assisted living program (state-funded component): introduction and definitions.
Amendment	Original Filing	No	Yes	173-51-02	Assisted living program (state-funded component): eligibility requirements.
Amendment	Original Filing	No	Yes	173-51-03	Assisted living program (state-funded component): disenrollment and other adverse actions.

11 Department of Commerce • Division of Real Estate

Total Rules: 7 Original Filing Date: 11/29/2021 Date of Revised Filing: 11/30/2021 Jurisdiction Ends: 2/2/2022 Public Hearing: 1/4/2022

<u>Rule Type</u>	<u>Action</u>	<u>CSI</u>	<u>FYR</u>	<u>Rule Number</u>	<u>Rule Title</u>
Amendment	Revised Filing	Yes	No	1301:5-1-12	Open public meetings.
Amendment	Revised Filing	Yes	No	1301:5-1-19	License reactivation and renewal.

Click on the rule number in blue above to view the rule in its entirety on the *Register of Ohio* website.

Amendment	Revised Filing	Yes	No	1301:5-1-20	Annual brokerage assessment.
Amendment	Revised Filing	Yes	No	1301:5-5-01	Statement to be displayed in brokerage office and included in information pamphlets.
Amendment	Revised Filing	Yes	No	1301:5-7-03	Criteria for course approvals.
Amendment	Revised Filing	Yes	No	1301:5-7-04	Continuing education course completion and certificates.
Amendment	Revised Filing	Yes	No	1301:5-7-09	Post-licensing education.

12 Department of Commerce • Real Estate Appraiser Board

Total Rules: 1	Original Filing Date: 11/29/2021				Jurisdiction Ends: 2/2/2022	Public Hearing: 1/4/2022
<u>Rule Type</u>	<u>Action</u>	<u>CSI</u>	<u>FYR</u>	<u>Rule Number</u>	<u>Rule Title</u>	
Amendment	Original Filing	Yes	Yes	1301:11-7-04	Medical exception.	

13 Department of Higher Education •

Total Rules: 1	Original Filing Date: 11/29/2021				Jurisdiction Ends: 2/2/2022	Public Hearing: 1/4/2022
<u>Rule Type</u>	<u>Action</u>	<u>CSI</u>	<u>FYR</u>	<u>Rule Number</u>	<u>Rule Title</u>	
New Rule	Original Filing	No	No	3333-1-65.14	Student Eligibility Requirements.	

14 Department of Higher Education •

Total Rules: 1	Original Filing Date: 11/30/2021	Date of Revised Filing: 1/4/2022			Jurisdiction Ends: 2/3/2022	Public Hearing: 1/5/2022
<u>Rule Type</u>	<u>Action</u>	<u>CSI</u>	<u>FYR</u>	<u>Rule Number</u>	<u>Rule Title</u>	
New Rule	Revised Filing	No	No	3333-1-09	Commercial Truck Driver Student Aid Program.	

15 Department of Insurance •

Total Rules: 9	Original Filing Date: 11/30/2021				Jurisdiction Ends: 2/3/2022	Public Hearing: 1/6/2022
<u>Rule Type</u>	<u>Action</u>	<u>CSI</u>	<u>FYR</u>	<u>Rule Number</u>	<u>Rule Title</u>	
Amendment	Original Filing	Yes	Yes	3901-1-07	Unfair trade practices.	
Amendment	Original Filing	Yes	Yes	3901-1-13	Mortgage guaranty insurance.	
Amendment	Original Filing	Yes	Yes	3901-1-24	Public insurance adjusters.	
Amendment	Original Filing	Yes	Yes	3901-1-48	"Ohio mine subsidence insurance underwriting association" and "mine subsidence insurance fund" plan of operation.	
Amendment	Original Filing	Yes	Yes	3901-1-54	Unfair property/casualty claims settlement practices.	
Rescission	Original Filing	Yes	Yes	3901-3-13	Health insurance reserves.	
New Rule	Original Filing	Yes	No	3901-3-13	Health insurance reserves.	

Click on the rule number in blue above to view the rule in its entirety on the *Register of Ohio* website.

Amendment Original Filing Yes Yes [3901-3-19](#)
 Amendment Original Filing Yes Yes [3901-7-04](#)

Corporate governance annual disclosure.
 Title insurance controlled business arrangements.

16 Department of Job and Family Services • Division of Social Services

Total Rules: 1 Original Filing Date: 11/23/2021

Jurisdiction Ends: 1/27/2022 Public Hearing: 12/28/2021

<u>Rule Type</u>	<u>Action</u>	<u>CSI</u>	<u>FYR</u>	<u>Rule Number</u>
Amendment	Original Filing	No	No	5101:2-52-10

Rule Title
 Interstate placement requirements for Ohio courts, parents, or legal guardians when placing a child in a residential placement in another state or territory.

17 Department of Job and Family Services • Division of Social Services

Total Rules: 3 Original Filing Date: 11/23/2021

Jurisdiction Ends: 1/27/2022 Public Hearing: 12/28/2021

<u>Rule Type</u>	<u>Action</u>	<u>CSI</u>	<u>FYR</u>	<u>Rule Number</u>
Amendment	Original Filing	No	Yes	5101:2-33-29
Amendment	Original Filing	No	Yes	5101:2-47-03.1
Amendment	Original Filing	No	Yes	5101:2-47-17

Rule Title
 Verification of United States citizenship and immigration status for all children in foster care.
 Qualified and disqualified alien eligibility for foster care maintenance and independent living services.
 Title IV- E foster care maintenance (FCM) program reimbursability:
 Reimbursements for FCM and child care for public foster homes, relative homes, and pre-finalized adoptive homes.

18 Department of Job and Family Services • Division of Social Services

Total Rules: 4 Original Filing Date: 11/23/2021

Jurisdiction Ends: 1/27/2022 Public Hearing: 12/28/2021

<u>Rule Type</u>	<u>Action</u>	<u>CSI</u>	<u>FYR</u>	<u>Rule Number</u>
Amendment	Original Filing	No	Yes	5101:2-25-01
Amendment	Original Filing	No	Yes	5101:2-25-02
Amendment	Original Filing	No	Yes	5101:2-25-03
Amendment	Original Filing	No	Yes	5101:2-25-07

Rule Title
 Uniform definitions of Title XX services and other definitions of terms used in Chapter 5101:2-25 of the Administrative Code.
 Title XX administration.
 Title XX county profile.
 Title XX reimbursement dependent upon correct determination of recipient eligibility.

19 Department of Mental Health and Addiction Services •

Total Rules: 3 Original Filing Date: 11/29/2021

Jurisdiction Ends: 2/2/2022 Public Hearing: 12/30/2021

<u>Rule Type</u>	<u>Action</u>	<u>CSI</u>	<u>FYR</u>	<u>Rule Number</u>
Amendment	Original Filing	No	Yes	5122-1-28
Amendment	Original Filing	No	Yes	5122-1-29

Rule Title
 Industrial and entertainment funds.
 Operation of regional psychiatric hospital commissaries.

Amendment Original Filing No Yes [5122-9-10](#) Management and control of internal funds.

20 Department of Mental Health and Addiction Services •

Total Rules: 1 Original Filing Date: 11/30/2021 Jurisdiction Ends: 2/3/2022 Public Hearing: 1/5/2022

Rule Type Action CSI FYR Rule Number Rule Title

Amendment Original Filing Yes Yes [5122-29-30](#) Eligible providers and supervisors.

Total Rules: 1 Original Filing Date: 11/30/2021 Date of Refiled Filing: 1/13/2022 Jurisdiction Ends: 2/12/2022 Public Hearing: 1/5/2022

Rule Type Action CSI FYR Rule Number Rule Title

Amendment Refiled Filing Yes Yes [5122-29-28](#) Intensive home based treatment (IHBT) service.

21 Department of Natural Resources • Division of Mineral Resources Management-Coal

Total Rules: 8 Original Filing Date: 11/30/2021 Jurisdiction Ends: 2/3/2022 Public Hearing: 1/5/2022

Rule Type Action CSI FYR Rule Number Rule Title

Amendment Original Filing Yes Yes [1501:13-1-14](#) Incorporation by reference.

Amendment Original Filing Yes Yes [1501:13-4-05](#) Permit application requirements for reclamation and operations plans.

Amendment Original Filing Yes Yes [1501:13-4-12](#) Requirements for permits for special categories of mining.

Amendment Original Filing Yes Yes [1501:13-4-13](#) Underground mining permit application requirements for information on environmental resources.

Amendment Original Filing Yes Yes [1501:13-4-14](#) Underground mining permit application requirements for reclamation and operations plans.

Amendment Original Filing Yes Yes [1501:13-7-03](#) Form, conditions, and terms of performance security.

Amendment Original Filing Yes Yes [1501:13-9-04](#) Protection of the hydrologic system.

Amendment Original Filing Yes Yes [1501:13-11-02](#) Support facilities and utility installations.

22 Department of Natural Resources • Division of Mineral Resources Management-Coal

Total Rules: 8 Original Filing Date: 11/30/2021 Jurisdiction Ends: 2/3/2022 Public Hearing: 1/5/2022

Rule Type Action CSI FYR Rule Number Rule Title

Amendment Original Filing Yes Yes [1501:13-1-10](#) Availability of records.

Amendment Original Filing Yes Yes [1501:13-4-09](#) General map requirements.

Amendment Original Filing Yes Yes [1501:13-7-01](#) General requirements for providing performance security for coal mining and reclamation operations.

Amendment Original Filing Yes Yes [1501:13-7-06](#) Performance security forfeiture criteria and procedures.

Amendment Original Filing Yes No [1501:13-12-03](#) Subsidence control.

Click on the rule number in blue above to view the rule in its entirety on the *Register of Ohio* website.

Amendment	Original Filing	Yes	No	1501:13-13-08	Restoration off the permit area by means of mitigation.
Amendment	Original Filing	Yes	Yes	1501:13-14-01	Inspections.
Amendment	Original Filing	Yes	No	1501:13-14-03	Civil penalties.

23 Department of Natural Resources • Division of Mineral Resources Management-Industrial Mineral

Total Rules: 2 Original Filing Date: 11/30/2021 Jurisdiction Ends: 2/3/2022 Public Hearing: 1/5/2022

<u>Rule Type</u>	<u>Action</u>	<u>CSI</u>	<u>FYR</u>	<u>Rule Number</u>	<u>Rule Title</u>
Amendment	Original Filing	Yes	Yes	1501:14-1-16	Incorporation by reference.
Amendment	Original Filing	Yes	Yes	1501:14-2-01	Incorporation by reference of mine safety standards.

24 Department of Natural Resources • Division of Mineral Resources Management-Industrial Mineral

Total Rules: 1 Original Filing Date: 11/30/2021 Jurisdiction Ends: 2/3/2022 Public Hearing: 1/5/2022

<u>Rule Type</u>	<u>Action</u>	<u>CSI</u>	<u>FYR</u>	<u>Rule Number</u>	<u>Rule Title</u>
Amendment	Original Filing	Yes	No	1501:14-1-04	Procedure for filing applications.

25 Department of Public Safety • Emergency Management Agency

Total Rules: 3 Original Filing Date: 11/29/2021 Jurisdiction Ends: 2/2/2022 Public Hearing: 12/30/2021

<u>Rule Type</u>	<u>Action</u>	<u>CSI</u>	<u>FYR</u>	<u>Rule Number</u>	<u>Rule Title</u>
Amendment	Original Filing	No	Yes	4501:3-5-01	Training.
Amendment	Original Filing	No	Yes	4501:3-6-01	Emergency operations plans and exercises.
Amendment	Original Filing	No	Yes	4501:3-7-01	Registration of volunteers.

Total Rules: 1 Original Filing Date: 11/29/2021 Date of Revised Filing: 11/30/2021 Jurisdiction Ends: 2/2/2022 Public Hearing: 12/30/2021

<u>Rule Type</u>	<u>Action</u>	<u>CSI</u>	<u>FYR</u>	<u>Rule Number</u>	<u>Rule Title</u>
Amendment	Revised Filing	No	Yes	4501:3-7-02	Registration of volunteer organizations.

26 Department of Taxation •

Total Rules: 1 Original Filing Date: 11/23/2021 Jurisdiction Ends: 1/27/2022 Public Hearing:

<u>Rule Type</u>	<u>Action</u>	<u>CSI</u>	<u>FYR</u>	<u>Rule Number</u>	<u>Rule Title</u>
New Rule	Original Filing	Yes	No	5703-9-63	Crude oil and natural gas production.

27 Medical Marijuana Control Program • Forms and Methods of Administration

Total Rules: 2 Original Filing Date: 11/29/2021 Jurisdiction Ends: 2/2/2022 Public Hearing: 1/6/2022

<u>Rule Type</u>	<u>Action</u>	<u>CSI</u>	<u>FYR</u>	<u>Rule Number</u>	<u>Rule Title</u>
------------------	---------------	------------	------------	--------------------	-------------------

Click on the rule number in blue above to view the rule in its entirety on the *Register of Ohio* website.

Rescission	Original Filing	Yes	Yes	3796:8-2-04	Quantity of medical marijuana that may be purchased by a patient or caregiver.
New Rule	Original Filing	Yes	No	3796:8-2-04	Quantity of medical marijuana that may be purchased by a patient or caregiver.
Total Rules: 3		Original Filing Date: 11/29/2021		Date of Revised Filing: 11/29/2021	Jurisdiction Ends: 2/2/2022
Public Hearing: 1/6/2022					
<u>Rule Type</u>	<u>Action</u>	<u>CSI</u>	<u>FYR</u>	<u>Rule Number</u>	<u>Rule Title</u>
Amendment	Revised Filing	Yes	Yes	3796:8-1-01	Definitions.
Amendment	Revised Filing	Yes	Yes	3796:8-2-03	Forms and form variations considered attractive to children.
Amendment	Revised Filing	Yes	Yes	3796:8-2-06	Portions, dosing, and units of medical marijuana sold at a dispensary.

28 Ohio Casino Control Commission •

Total Rules: 42		Original Filing Date: 11/23/2021		Jurisdiction Ends: 1/27/2022	
Public Hearing: 12/30/2021					
<u>Rule Type</u>	<u>Action</u>	<u>CSI</u>	<u>FYR</u>	<u>Rule Number</u>	<u>Rule Title</u>
Amendment	Original Filing	Yes	Yes	3772-10-01	Definitions.
Rescission	Original Filing	Yes	Yes	3772-10-02	Internal controls.
New Rule	Original Filing	Yes	No	3772-10-02	Internal controls.
Amendment	Original Filing	Yes	Yes	3772-10-03	Casino operator's organization.
Rescission	Original Filing	Yes	Yes	3772-10-04	Accounting records.
New Rule	Original Filing	Yes	No	3772-10-04	Controlled demonstration.
Rescission	Original Filing	Yes	Yes	3772-10-05	Forms, records, and documents.
New Rule	Original Filing	Yes	No	3772-10-05	Forms, records, and documents.
Amendment	Original Filing	Yes	Yes	3772-10-06	Standard financial reports.
Rescission	Original Filing	Yes	Yes	3772-10-07	Annual audit; other reports; suspicious transaction reporting.
New Rule	Original Filing	Yes	No	3772-10-07	Audits; other reports; suspicious transaction reporting.
Amendment	Original Filing	Yes	Yes	3772-10-08	Procedures for monitoring and reviewing game operations.
Amendment	Original Filing	Yes	Yes	3772-10-09	Complimentaries.
Amendment	Original Filing	Yes	Yes	3772-10-10	Patron financial transactions at the cashier's cage.
New Rule	Original Filing	Yes	No	3772-10-11	Credit.
New Rule	Original Filing	Yes	No	3772-10-12	Access controls.
Rescission	Original Filing	Yes	Yes	3772-10-13	Patron deposits.
New Rule	Original Filing	Yes	No	3772-10-13	Signature requirements.
Amendment	Original Filing	Yes	Yes	3772-10-14	Internal audit standards.
Rescission	Original Filing	Yes	Yes	3772-10-15	Information technology controls.

Click on the rule number in blue above to view the rule in its entirety on the *Register of Ohio* website.

JOINT COMMITTEE ON AGENCY RULE REVIEW

1/25/2022 - 11:00 AM

Senate Finance Hearing Room (Finan Hearing Room)

FINAL REGULAR AGENDA

FINAL REGULAR AGENDA

New Rule	Original Filing	Yes	No	3772-10-15	Information technology controls.
Rescission	Original Filing	Yes	Yes	3772-10-16	Security of the cashier's cages, main bank, and count rooms.
New Rule	Original Filing	Yes	No	3772-10-16	Cashier's cages, main bank, and count rooms.
Amendment	Original Filing	Yes	Yes	3772-10-17	Accounting controls for the cage, main bank, and redemption kiosks.
Rescission	Original Filing	Yes	Yes	3772-10-18	Table drop boxes and electronic gaming equipment bill validator canisters: physical requirements and transportation.
New Rule	Original Filing	Yes	No	3772-10-18	Table drop boxes and electronic gaming equipment bill validator canisters: physical requirements and transportation.
Rescission	Original Filing	Yes	Yes	3772-10-19	Count procedures.
New Rule	Original Filing	Yes	No	3772-10-19	Count procedures.
Rescission	Original Filing	Yes	Yes	3772-10-20	Unsecured currency.
New Rule	Original Filing	Yes	No	3772-10-20	Unsecured currency.
Rescission	Original Filing	Yes	Yes	3772-10-21	Manual game payouts.
New Rule	Original Filing	Yes	No	3772-10-21	Manual game payouts.
Rescission	Original Filing	Yes	Yes	3772-10-22	Tips and gratuities.
New Rule	Original Filing	Yes	No	3772-10-22	Tips and gratuities.
Rescission	Original Filing	Yes	Yes	3772-10-23	Credit.
New Rule	Original Filing	Yes	No	3772-10-23	Other duties.
Rescission	Original Filing	Yes	Yes	3772-10-24	Signature requirements.
Rescission	Original Filing	Yes	Yes	3772-10-25	Unclaimed winnings.
Rescission	Original Filing	Yes	Yes	3772-10-26	Access controls.
Rescission	Original Filing	Yes	Yes	3772-10-27	Controlled demonstration.
Rescission	Original Filing	Yes	Yes	3772-10-28	Amendments to internal control plans.
Rescission	Original Filing	Yes	Yes	3772-10-30	Investigation and certification of contractors by casino operators.

29 Ohio Department of Medicaid •

Total Rules: 1	Original Filing Date: 11/30/2021	Jurisdiction Ends: 2/3/2022	Public Hearing: 1/3/2022
<u>Rule Type</u>	<u>Action</u>	<u>CSI</u>	<u>FYR</u>
<u>Rule Number</u>	<u>Rule Title</u>		
Amendment	Original Filing	No	Yes
5160-2-03	Conditions and limitations.		

30 Ohio Department of Medicaid •

Total Rules: 1	Original Filing Date: 11/30/2021	Jurisdiction Ends: 2/3/2022	Public Hearing: 1/3/2022
----------------	----------------------------------	-----------------------------	--------------------------

Click on the rule number in blue above to view the rule in its entirety on the *Register of Ohio* website.

<u>Rule Type</u>	<u>Action</u>	<u>CSI</u>	<u>FYR</u>	<u>Rule Number</u>	<u>Rule Title</u>
Amendment	Original Filing	No	No	5160-2-65	Inpatient hospital reimbursement.

31 Ohio Department of Medicaid •

Total Rules: 4 Original Filing Date: 11/30/2021 Jurisdiction Ends: 2/3/2022 Public Hearing: 1/3/2022

<u>Rule Type</u>	<u>Action</u>	<u>CSI</u>	<u>FYR</u>	<u>Rule Number</u>	<u>Rule Title</u>
Rescission	Original Filing	No	Yes	5160-27-05	Mental health intensive home based treatment service.
New Rule	Original Filing	Yes	No	5160-27-05	Intensive home based treatment service.
Amendment	Original Filing	No	No	5160-27-06	Therapeutic behavioral group service-hourly and per diem.
Amendment	Original Filing	No	No	5160-27-08	Mental health therapeutic behavioral services and psychosocial rehabilitation.

32 Ohio Department of Medicaid •

Total Rules: 1 Original Filing Date: 11/30/2021 Jurisdiction Ends: 2/3/2022 Public Hearing: 1/3/2022

<u>Rule Type</u>	<u>Action</u>	<u>CSI</u>	<u>FYR</u>	<u>Rule Number</u>	<u>Rule Title</u>
Amendment	Original Filing	No	Yes	5160-4-01	Physician services.

33 Ohio Department of Medicaid •

Total Rules: 1 Original Filing Date: 11/30/2021 Jurisdiction Ends: 2/3/2022 Public Hearing: 1/3/2022

<u>Rule Type</u>	<u>Action</u>	<u>CSI</u>	<u>FYR</u>	<u>Rule Number</u>	<u>Rule Title</u>
Amendment	Original Filing	No	Yes	5160-4-12	Immunizations, injections and infusions (including trigger-point injections), skin substitutes, and provider-administered pharmaceuticals.

34 Ohio Environmental Protection Agency •

Total Rules: 1 Original Filing Date: 1/22/2020 Date of Refiled Filing: 1/4/2022 Jurisdiction Ends: 2/3/2022 Public Hearing: 2/26/2020

<u>Rule Type</u>	<u>Action</u>	<u>CSI</u>	<u>FYR</u>	<u>Rule Number</u>	<u>Rule Title</u>
Amendment	Refiled Filing	Yes	Yes	3745-81-23	Inorganic chemical monitoring requirements.

35 Ohio Environmental Protection Agency •

Total Rules: 5 Original Filing Date: 11/29/2021 Date of Revised Filing: 11/29/2021 Jurisdiction Ends: 2/2/2022 Public Hearing: 1/3/2022

<u>Rule Type</u>	<u>Action</u>	<u>CSI</u>	<u>FYR</u>	<u>Rule Number</u>	<u>Rule Title</u>
Amendment	Revised Filing	Yes	No	3745-110-01	Definitions.
Amendment	Revised Filing	Yes	No	3745-110-02	Applicability.
Amendment	Revised Filing	Yes	No	3745-110-03	RACT requirements and/or limitations for emissions of NOx from stationary sources.

Click on the rule number in blue above to view the rule in its entirety on the *Register of Ohio* website.

Amendment Revised Filing Yes No [3745-110-04](#) Compliance deadlines.
 Amendment Revised Filing Yes No [3745-110-05](#) Compliance methods.

36 Ohio Environmental Protection Agency •

Total Rules: 19 Original Filing Date: 11/29/2021 Date of Revised Filing: 11/29/2021 Jurisdiction Ends: 2/2/2022 Public Hearing: 1/3/2022

<u>Rule Type</u>	<u>Action</u>	<u>CSI</u>	<u>FYR</u>	<u>Rule Number</u>	<u>Rule Title</u>
Amendment	Revised Filing	Yes	Yes	3745-21-01	Definitions and incorporation by reference.
Amendment	Revised Filing	Yes	Yes	3745-21-04	Compliance time schedules.
Amendment	Revised Filing	Yes	Yes	3745-21-07	Control of emissions of organic materials from stationary sources (i.e., emissions that are not regulated by rule 3745-21-09, 3745-21-12 to 3745-21-16, or 3745-21-18 to 3745-21-29 of the Administrative Code).
Amendment	Revised Filing	Yes	Yes	3745-21-09	Control of emissions of volatile organic compounds from stationary sources and perchloroethylene from dry cleaning facilities.
Amendment	Revised Filing	Yes	Yes	3745-21-10	Compliance test methods and procedures.
New Rule	Revised Filing	Yes	No	3745-21-11	Reasonably available control technology studies for non-CTG sources in ozone nonattainment areas.
Amendment	Revised Filing	Yes	Yes	3745-21-15	Control of volatile organic compound emissions from wood furniture manufacturing operations.
Amendment	Revised Filing	Yes	Yes	3745-21-18	Commercial motor vehicle and mobile equipment refinishing operations.
Amendment	Revised Filing	Yes	Yes	3745-21-19	Control of volatile organic compound emissions from aerospace manufacturing and rework facilities.
Amendment	Revised Filing	Yes	Yes	3745-21-20	Control of volatile organic emissions from shipbuilding and ship repair operations (marine coatings).
Amendment	Revised Filing	Yes	Yes	3745-21-21	Storage of volatile organic liquids in fixed roof tanks and external floating roof tanks.
Amendment	Revised Filing	Yes	Yes	3745-21-22	Control of volatile organic compound emissions from offset lithographic printing and letterpress printing facilities.
Amendment	Revised Filing	Yes	Yes	3745-21-23	Control of volatile organic compound emissions from industrial solvent cleaning operations.
Amendment	Revised Filing	Yes	Yes	3745-21-24	Flat wood paneling coatings.
Amendment	Revised Filing	Yes	Yes	3745-21-25	Control of VOC emissions from reinforced plastic composites production operations.
Amendment	Revised Filing	Yes	Yes	3745-21-26	Surface coating of miscellaneous metal and plastic parts.

Click on the rule number in blue above to view the rule in its entirety on the *Register of Ohio* website.

Amendment	Revised Filing	Yes	Yes	3745-21-27	Boat manufacturing.
Amendment	Revised Filing	Yes	Yes	3745-21-28	Miscellaneous industrial adhesives and sealants.
Amendment	Revised Filing	Yes	Yes	3745-21-29	Control of volatile organic compound emissions from automobile and light-duty truck assembly coating operations, heavier vehicle assembly coating operations, and cleaning operations associated with these coating operations.

37 Ohio Environmental Protection Agency •

Total Rules: 2	Original Filing Date: 11/2/2021	Date of Refiled Filing: 1/4/2022	Jurisdiction Ends: 2/3/2022	Public Hearing: 12/3/2021	
<u>Rule Type</u>	<u>Action</u>	<u>CSI</u>	<u>FYR</u>	<u>Rule Number</u>	<u>Rule Title</u>
Amendment	Refiled Filing	Yes	No	3745-7-12	Suspension or revocation of certification.
Amendment	Refiled Filing	Yes	No	3745-91-02	Application for approval of plans.

38 Ohio Environmental Protection Agency •

Total Rules: 1	Original Filing Date: 11/29/2021	Jurisdiction Ends: 2/2/2022	Public Hearing: 1/4/2022		
<u>Rule Type</u>	<u>Action</u>	<u>CSI</u>	<u>FYR</u>	<u>Rule Number</u>	<u>Rule Title</u>
Amendment	Original Filing	Yes	Yes	3745-86-01	Emergency loans.

39 Ohio Environmental Protection Agency •

Total Rules: 2	Original Filing Date: 11/30/2021	Jurisdiction Ends: 2/3/2022	Public Hearing: 1/4/2022		
<u>Rule Type</u>	<u>Action</u>	<u>CSI</u>	<u>FYR</u>	<u>Rule Number</u>	<u>Rule Title</u>
Rescission	Original Filing	Yes	Yes	3745-71-01	Definitions and reference to materials.
Rescission	Original Filing	Yes	Yes	3745-71-03	Methods of ambient air measurement.

40 Ohio Medical Transportation Board •

Total Rules: 12	Original Filing Date: 11/29/2021	Jurisdiction Ends: 2/2/2022	Public Hearing: 1/4/2022		
<u>Rule Type</u>	<u>Action</u>	<u>CSI</u>	<u>FYR</u>	<u>Rule Number</u>	<u>Rule Title</u>
Amendment	Original Filing	Yes	Yes	4766-2-01	Definitions.
Amendment	Original Filing	Yes	Yes	4766-2-02	Application for initial or renewal licensure.
Amendment	Original Filing	Yes	Yes	4766-2-03	Fees.
Amendment	Original Filing	Yes	Yes	4766-2-04	Physical facilities.
Amendment	Original Filing	Yes	Yes	4766-2-06	Communication requirements.
Amendment	Original Filing	Yes	Yes	4766-2-08	Vehicle inspections and equipment requirements.
Amendment	Original Filing	Yes	Yes	4766-2-11	Use of lights and other warning devices.

Click on the rule number in blue above to view the rule in its entirety on the *Register of Ohio* website.

Amendment	Original Filing	Yes	Yes	4766-2-12	Temporary and disaster operations.
Amendment	Original Filing	Yes	Yes	4766-2-13	Staffing compliance.
Amendment	Original Filing	Yes	Yes	4766-2-15	Changes to be reported to the board.
Rescission	Original Filing	Yes	Yes	4766-2-18	Incorporated by reference.
New Rule	Original Filing	Yes	No	4766-2-18	Incorporated by reference.

41 Opportunities for Ohioans with Disabilities • Business Enterprise Program

Total Rules: 3 Original Filing Date: 11/19/2021 Date of Refiled Filing: 1/4/2022 Jurisdiction Ends: 2/3/2022 Public Hearing: 12/21/2021

<u>Rule Type</u>	<u>Action</u>	<u>CSI</u>	<u>FYR</u>	<u>Rule Number</u>	<u>Rule Title</u>
New Rule	Refiled Filing	Yes	No	3304:1-21-04	Operator's responsibilities, leave and self-employment status.
New Rule	Refiled Filing	Yes	No	3304:1-21-06	Bureau-operator, temporary bureau-operator agreements.
New Rule	Refiled Filing	Yes	No	3304:1-21-14	grievance.

42 State Racing Commission •

Total Rules: 4 Original Filing Date: 11/22/2021 Jurisdiction Ends: 1/26/2022 Public Hearing: 11/16/2021

<u>Rule Type</u>	<u>Action</u>	<u>CSI</u>	<u>FYR</u>	<u>Rule Number</u>	<u>Rule Title</u>
Rescission	Original Filing	Yes	Yes	3769-3-35	Super high five wagering.
New Rule	Original Filing	Yes	No	3769-3-35	Pentafecta Pools.
Rescission	Original Filing	Yes	Yes	3769-13-35	Super high five wagering.
New Rule	Original Filing	Yes	No	3769-13-35	Pentafecta Pools.

43 Treasurer of State •

Total Rules: 3 Original Filing Date: 11/30/2021 Jurisdiction Ends: 2/3/2022 Public Hearing: 1/6/2022

<u>Rule Type</u>	<u>Action</u>	<u>CSI</u>	<u>FYR</u>	<u>Rule Number</u>	<u>Rule Title</u>
Amendment	Original Filing	No	No	113-5-01	Exemptions from continuing education requirements.
New Rule	Original Filing	No	No	113-5-04	County treasurer continuing education biennial cycle.
New Rule	Original Filing	No	No	113-5-05	Initial education requirements for appointed and specially elected county treasurers.

Withdrawn

44 Ohio Speech and Hearing Professionals Board •

Click on the rule number in blue above to view the rule in its entirety on the *Register of Ohio* website.

Total Rules: 2 Original Filing Date: 12/21/2021 Date of Withdrawn Filing: 12/30/2021 Jurisdiction Ends: Public Hearing: 1/31/2022

<u>Rule Type</u>	<u>Action</u>	<u>CSI</u>	<u>FYR</u>	<u>Rule Number</u>	<u>Rule Title</u>
Amendment	Withdrawn Filing	Yes	Yes	4753-3-10	Exempt practice; renewal.
Amendment	Withdrawn Filing	Yes	Yes	4753-7-02	Supervision requirements; aides.

45 State Veterinary Medical Licensing Board •

Total Rules: 1 Original Filing Date: 12/3/2021 Date of Withdrawn Filing: 12/7/2021 Jurisdiction Ends: Public Hearing: 1/12/2022

<u>Rule Type</u>	<u>Action</u>	<u>CSI</u>	<u>FYR</u>	<u>Rule Number</u>	<u>Rule Title</u>
Amendment	Withdrawn Filing	Yes	Yes	4741-2-01	General provisions of a veterinary business facility license.

JOINT COMMITTEE ON AGENCY RULE REVIEW
Agenda - 3/8/2022 - 11:00 AM
Senate Finance Hearing Room (Finan Hearing Room)



FINAL REGULAR AGENDA

FINAL REGULAR AGENDA

1 Broadcast Educational Media Commission •

Total Rules: 1 Original Filing Date: 12/2/2021 Jurisdiction Ends: 3/10/2022 Public Hearing: 1/4/2022

<u>Rule Type</u>	<u>Action</u>	<u>CSI</u>	<u>FYR</u>	<u>Rule Number</u>	<u>Rule Title</u>
Amendment	Original Filing	No	Yes	3353-1-14	Definitions.

2 Department of Administrative Services • Division of Human Resources

Total Rules: 2 Original Filing Date: 1/18/2022 Jurisdiction Ends: 3/24/2022 Public Hearing: 2/22/2022

<u>Rule Type</u>	<u>Action</u>	<u>CSI</u>	<u>FYR</u>	<u>Rule Number</u>	<u>Rule Title</u>
Amendment	Original Filing	No	Yes	123:1-76-01	Drug-free workplace definitions of terms.
Amendment	Original Filing	No	Yes	123:1-76-11	Finding of employee drug use and disciplinary consequences.

3 Department of Aging •

Total Rules: 1 Original Filing Date: 8/26/2021 Date of Refiled Filing: 2/7/2022 Jurisdiction Ends: 3/9/2022 Public Hearing: 9/27/2021

<u>Rule Type</u>	<u>Action</u>	<u>CSI</u>	<u>FYR</u>	<u>Rule Number</u>	<u>Rule Title</u>
Amendment	Refiled Filing	Yes	Yes	173-4-09	Older Americans Act nutrition program: nutrition health screening.

4 Department of Aging •

Total Rules: 1 Original Filing Date: 10/5/2021 Date of Refiled Filing: 2/7/2022 Jurisdiction Ends: 3/9/2022 Public Hearing: 11/8/2021

<u>Rule Type</u>	<u>Action</u>	<u>CSI</u>	<u>FYR</u>	<u>Rule Number</u>	<u>Rule Title</u>
Amendment	Refiled Filing	Yes	Yes	173-3-05.1	Older Americans Act: procurement standards for renewable and multi-year AAA-provider agreements.

5 Department of Aging •

Total Rules: 17 Original Filing Date: 1/18/2022 Jurisdiction Ends: 3/24/2022 Public Hearing: 2/18/2022

<u>Rule Type</u>	<u>Action</u>	<u>CSI</u>	<u>FYR</u>	<u>Rule Number</u>	<u>Rule Title</u>
Amendment	Original Filing	Yes	Yes	173-39-01	ODA provider certification: introduction and definitions.

Click on the rule number in blue above to view the rule in its entirety on the *Register of Ohio* website.

Amendment	Original Filing	Yes	Yes	173-39-02	ODA provider certification: requirements for providers to become, and to remain, certified.
Amendment	Original Filing	Yes	Yes	173-39-02.1	ODA provider certification: adult day service.
Amendment	Original Filing	Yes	Yes	173-39-02.10	ODA provider certification: nutritional consultations.
Amendment	Original Filing	Yes	Yes	173-39-02.11	ODA provider certification: personal care.
Amendment	Original Filing	Yes	Yes	173-39-02.12	ODA provider certification: social work counseling service.
Amendment	Original Filing	Yes	Yes	173-39-02.13	ODA provider certification: non-emergency medical transportation.
Amendment	Original Filing	Yes	Yes	173-39-02.20	ODA provider certification: enhanced community living.
Amendment	Original Filing	Yes	Yes	173-39-02.4	ODA provider certification: choices home care attendant service (CHCAS).
Amendment	Original Filing	Yes	Yes	173-39-02.7	ODA provider certification: home medical equipment and supplies.
Amendment	Original Filing	Yes	Yes	173-39-02.8	ODA provider certification: homemaker.
Amendment	Original Filing	Yes	Yes	173-39-03	ODA provider certification: applying for certification.
Amendment	Original Filing	Yes	Yes	173-39-03.1	ODA provider certification: federal heightened scrutiny of provider settings with institutional characteristics.
Amendment	Original Filing	Yes	Yes	173-39-03.2	ODA provider certification: changes of ownership interest or organizational structure.
Amendment	Original Filing	Yes	Yes	173-39-03.3	ODA provider certification: applying to be certified to provide additional services.
Amendment	Original Filing	Yes	Yes	173-39-03.4	ODA provider certification: applying to be certified in additional regions or to certify additional business sites.
Amendment	Original Filing	Yes	Yes	173-39-04	ODA provider certification: structural compliance reviews.

6 Department of Commerce •

Total Rules: 1	Original Filing Date: 1/4/2022	Jurisdiction Ends: 3/10/2022	Public Hearing: 2/9/2022		
<u>Rule Type</u>	<u>Action</u>	<u>CSI</u>	<u>FYR</u>	<u>Rule Number</u>	<u>Rule Title</u>
Amendment	Original Filing	Yes	Yes	1301-1-02	Financial literacy education fund.

7 Department of Commerce • Division of Industrial Compliance

Total Rules: 1	Original Filing Date: 12/17/2021	Jurisdiction Ends: 3/10/2022	Public Hearing: 1/20/2022		
<u>Rule Type</u>	<u>Action</u>	<u>CSI</u>	<u>FYR</u>	<u>Rule Number</u>	<u>Rule Title</u>
New Rule	Original Filing	Yes	No	1301:3-2-10	Temporary plumbing inspector certificates for members of the military and their spouses.

8 Department of Commerce • Division of Real Estate

Click on the rule number in blue above to view the rule in its entirety on the Register of Ohio website.

Total Rules: 1 Original Filing Date: 1/18/2022

Jurisdiction Ends: 3/24/2022

Public Hearing: 2/24/2022

<u>Rule Type</u>	<u>Action</u>	<u>CSI</u>	<u>FYR</u>	<u>Rule Number</u>	<u>Rule Title</u>
Amendment	Original Filing	No	No	1301:5-6-10	Residential property disclosure form.

9 Department of Commerce • Ohio Construction Industry Licensing Board

Total Rules: 8 Original Filing Date: 12/17/2021

Jurisdiction Ends: 3/10/2022

Public Hearing: 1/20/2022

<u>Rule Type</u>	<u>Action</u>	<u>CSI</u>	<u>FYR</u>	<u>Rule Number</u>	<u>Rule Title</u>
Amendment	Original Filing	Yes	Yes	4101:16-1-01	Definitions.
Amendment	Original Filing	Yes	Yes	4101:16-1-02	Notice of administrative rules hearing.
Amendment	Original Filing	Yes	Yes	4101:16-1-03	Public meetings.
Amendment	Original Filing	Yes	Yes	4101:16-1-04	Administrative section.
Amendment	Original Filing	Yes	Yes	4101:16-1-05	Investigations.
Amendment	Original Filing	Yes	Yes	4101:16-1-06	Disciplinary action against a licensee.
Amendment	Original Filing	Yes	Yes	4101:16-1-07	Adjudication hearings.
Amendment	Original Filing	Yes	Yes	4101:16-1-08	Compliant contractor program.

10 Department of Commerce • Ohio Construction Industry Licensing Board

Total Rules: 14 Original Filing Date: 12/17/2021

Jurisdiction Ends: 3/10/2022

Public Hearing: 1/20/2022

<u>Rule Type</u>	<u>Action</u>	<u>CSI</u>	<u>FYR</u>	<u>Rule Number</u>	<u>Rule Title</u>
Amendment	Original Filing	Yes	Yes	4101:16-2-01	Qualifications to take licensing examination.
Amendment	Original Filing	Yes	Yes	4101:16-2-02	Application procedures for licensing examination and results.
Amendment	Original Filing	Yes	Yes	4101:16-2-03	Examinations.
Amendment	Original Filing	Yes	Yes	4101:16-2-04	Issuance of licenses to successful applicants.
Amendment	Original Filing	Yes	Yes	4101:16-2-05	Display of license.
Amendment	Original Filing	Yes	Yes	4101:16-2-06	Notice of renewal date and application for renewal.
Amendment	Original Filing	Yes	Yes	4101:16-2-07	Renewal of license.
Amendment	Original Filing	Yes	Yes	4101:16-2-08	Continuing education - hours of instruction requirements.
Amendment	Original Filing	Yes	Yes	4101:16-2-09	Fees and insurance.
Amendment	Original Filing	Yes	Yes	4101:16-2-10	Reciprocity.
Amendment	Original Filing	Yes	Yes	4101:16-2-11	Conditional licenses.
Amendment	Original Filing	Yes	Yes	4101:16-2-12	Inactive status.

Amendment	Original Filing	Yes	Yes	4101:16-2-13	Military provisions related to licensure.
New Rule	Original Filing	Yes	No	4101:16-2-14	Temporary licenses for members of the military and their spouses.

11 Department of Commerce • Ohio Construction Industry Licensing Board

Total Rules: 3 Original Filing Date: 12/17/2021 Date of Revised Filing: Jurisdiction Ends: 3/10/2022 Public Hearing: 1/20/2022

<u>Rule Type</u>	<u>Action</u>	<u>CSI</u>	<u>FYR</u>	<u>Rule Number</u>	<u>Rule Title</u>
Amendment	Original Filing	Yes	Yes	4101:16-3-01	Approval of training agencies.
Amendment	Original Filing	Yes	Yes	4101:16-3-02	Continuing education requirements - reporting.
Amendment	Original Filing	Yes	Yes	4101:16-3-03	Continuing education - course approval.

12 Department of Development • Brownfield Remediation Program

Total Rules: 6 Original Filing Date: 1/20/2022 Date of Revised Filing: 2/23/2022 Jurisdiction Ends: 3/26/2022 Public Hearing: 2/24/2022

<u>Rule Type</u>	<u>Action</u>	<u>CSI</u>	<u>FYR</u>	<u>Rule Number</u>	<u>Rule Title</u>
New Rule	Revised Filing	Yes	No	122:31-1-01	Definitions.
New Rule	Revised Filing	Yes	No	122:31-1-02	Eligible Properties.
New Rule	Revised Filing	Yes	No	122:31-1-03	Eligible Applicant.
New Rule	Revised Filing	Yes	No	122:31-1-04	Application.
New Rule	Revised Filing	Yes	No	122:31-1-05	Grant Agreement.
New Rule	Revised Filing	Yes	No	122:31-1-06	Reporting.

13 Department of Development • Building Demolition and Site Revitalization Program

Total Rules: 6 Original Filing Date: 1/20/2022 Date of Revised Filing: 2/23/2022 Jurisdiction Ends: 3/26/2022 Public Hearing: 2/24/2022

<u>Rule Type</u>	<u>Action</u>	<u>CSI</u>	<u>FYR</u>	<u>Rule Number</u>	<u>Rule Title</u>
New Rule	Revised Filing	Yes	No	122:32-1-01	Definitions.
New Rule	Revised Filing	Yes	No	122:32-1-02	Eligible Properties.
New Rule	Revised Filing	Yes	No	122:32-1-03	Eligible Applicant.
New Rule	Revised Filing	Yes	No	122:32-1-04	Application.
New Rule	Revised Filing	Yes	No	122:32-1-05	Grant Agreement.
New Rule	Revised Filing	Yes	No	122:32-1-06	Reporting.

14 Department of Education •

Total Rules: 11 Original Filing Date: 1/14/2022 Date of Revised Filing: 1/25/2022 Jurisdiction Ends: 3/20/2022 Public Hearing: 2/15/2022

<u>Rule Type</u>	<u>Action</u>	<u>CSI</u>	<u>FYR</u>	<u>Rule Number</u>	<u>Rule Title</u>
------------------	---------------	------------	------------	--------------------	-------------------

Click on the rule number in blue above to view the rule in its entirety on the *Register of Ohio* website.

JOINT COMMITTEE ON AGENCY RULE REVIEW

3/8/2022 - 11:00 AM

Senate Finance Hearing Room (Finan Hearing Room)

FINAL REGULAR AGENDA

FINAL REGULAR AGENDA

Amendment	Revised Filing	No	Yes	3301-24-25	Senior professional license renewal.
Amendment	Revised Filing	No	Yes	3301-24-26	Lead professional educator license renewal.
Amendment	Revised Filing	No	Yes	3301-27-01	Qualifications to direct, supervise, or coach a pupil-activity program.
New Rule	Revised Filing	No	No	3301-83-25	Transportation collaboration grant.
Amendment	Revised Filing	No	Yes	3301-91-01	Eligibility for receiving state matching funds.
Amendment	Revised Filing	No	Yes	3301-91-04	Calculation of payment.
Rescission	Revised Filing	No	Yes	3301-91-07	Appeal for extension of time for compliance.
Rescission	Revised Filing	No	Yes	3301-91-08	Criteria for granting extension of time.
Amendment	Revised Filing	No	Yes	3301-91-09	Guidance for approving food to be sold in schools.
New Rule	Revised Filing	No	No	3301-91-10	Establishing summer food service programs at school sites and associated cost.
Amendment	Revised Filing	No	Yes	3301-105-01	Funding for educational service centers.

Total Rules: 1 Original Filing Date: 1/14/2022 Date of Revised Filing: 2/4/2022 Jurisdiction Ends: 3/20/2022 Public Hearing: 2/15/2022

<u>Rule Type</u>	<u>Action</u>	<u>CSI</u>	<u>FYR</u>	<u>Rule Number</u>	<u>Rule Title</u>
------------------	---------------	------------	------------	--------------------	-------------------

Amendment	Revised Filing	No	Yes	3301-30-01	Ohio department of youth services and Ohio department of rehabilitation and correction schools.
-----------	----------------	----	-----	----------------------------	---

Total Rules: 1 Original Filing Date: 1/14/2022 Date of Revised Filing: 2/9/2022 Jurisdiction Ends: 3/20/2022 Public Hearing: 2/15/2022

<u>Rule Type</u>	<u>Action</u>	<u>CSI</u>	<u>FYR</u>	<u>Rule Number</u>	<u>Rule Title</u>
------------------	---------------	------------	------------	--------------------	-------------------

New Rule	Revised Filing	No	No	3301-91-07	Appeal for extension of time for compliance.
----------	----------------	----	----	----------------------------	--

15 Department of Health • Radiation Control

Total Rules: 1 Original Filing Date: 11/3/2021 Date of Revised Filing: 12/2/2021 Jurisdiction Ends: 3/10/2022 Public Hearing: 12/9/2021

<u>Rule Type</u>	<u>Action</u>	<u>CSI</u>	<u>FYR</u>	<u>Rule Number</u>	<u>Rule Title</u>
------------------	---------------	------------	------------	--------------------	-------------------

Amendment	Revised Filing	Yes	Yes	3701:1-38-18	Posting, labeling, and receipt of packages.
-----------	----------------	-----	-----	------------------------------	---

16 Department of Higher Education •

Total Rules: 1 Original Filing Date: 1/6/2022 Date of Revised Filing: 2/10/2022 Jurisdiction Ends: 3/12/2022 Public Hearing: 2/7/2022

<u>Rule Type</u>	<u>Action</u>	<u>CSI</u>	<u>FYR</u>	<u>Rule Number</u>	<u>Rule Title</u>
------------------	---------------	------------	------------	--------------------	-------------------

Amendment	Revised Filing	No	No	3333-1-10	Ohio student residency for state subsidy and tuition surcharge purposes.
-----------	----------------	----	----	---------------------------	--

17 Department of Job and Family Services • Child Support

Total Rules: 1 Original Filing Date: 1/11/2022 Jurisdiction Ends: 3/17/2022 Public Hearing: 2/17/2022

<u>Rule Type</u>	<u>Action</u>	<u>CSI</u>	<u>FYR</u>	<u>Rule Number</u>	<u>Rule Title</u>
------------------	---------------	------------	------------	--------------------	-------------------

Click on the rule number in blue above to view the rule in its entirety on the *Register of Ohio* website.

Amendment Original Filing No No [5101:12-60-99](#) Chapter 5101:12-60 forms - order administration.

18 Department of Job and Family Services • Division of Public Assistance

Total Rules: 3 Original Filing Date: 12/22/2021 Date of Revised Filing: 1/12/2022 Jurisdiction Ends: 3/10/2022 Public Hearing: 1/27/2022

<u>Rule Type</u>	<u>Action</u>	<u>CSI</u>	<u>FYR</u>	<u>Rule Number</u>	<u>Rule Title</u>
Amendment	Revised Filing	No	Yes	5101:1-3-12.3	Work experience program.
Rescission	Revised Filing	No	Yes	5101:1-3-12.4	On-the-job training.
New Rule	Revised Filing	No	No	5101:1-3-12.4	On-the-job training.

19 Department of Job and Family Services • Division of Public Assistance

Total Rules: 1 Original Filing Date: 12/22/2021 Jurisdiction Ends: 3/10/2022 Public Hearing: 1/27/2022

<u>Rule Type</u>	<u>Action</u>	<u>CSI</u>	<u>FYR</u>	<u>Rule Number</u>	<u>Rule Title</u>
Amendment	Original Filing	No	Yes	5101:1-3-12.8	Providing child care services to an individual who is participating in a community service program.

20 Department of Job and Family Services • Division of Social Services

Total Rules: 1 Original Filing Date: 11/10/2021 Date of Refiled Filing: 2/17/2022 Jurisdiction Ends: 3/19/2022 Public Hearing: 12/16/2021

<u>Rule Type</u>	<u>Action</u>	<u>CSI</u>	<u>FYR</u>	<u>Rule Number</u>	<u>Rule Title</u>
Amendment	Refiled Filing	No	No	5101:2-16-02	Application and qualification process for receipt of publicly funded child care benefits.

21 Department of Job and Family Services • Division of Social Services

Total Rules: 1 Original Filing Date: 12/8/2021 Jurisdiction Ends: 3/10/2022 Public Hearing: 1/13/2022

<u>Rule Type</u>	<u>Action</u>	<u>CSI</u>	<u>FYR</u>	<u>Rule Number</u>	<u>Rule Title</u>
Amendment	Original Filing	Yes	No	5101:2-42-93	Change of placement or visitation plan prior to journalization of case plan.

22 Department of Job and Family Services • Division of Social Services

Total Rules: 1 Original Filing Date: 12/14/2021 Jurisdiction Ends: 3/10/2022 Public Hearing: 1/20/2022

<u>Rule Type</u>	<u>Action</u>	<u>CSI</u>	<u>FYR</u>	<u>Rule Number</u>	<u>Rule Title</u>
Amendment	Original Filing	No	No	5101:2-44-05.2	Medicaid eligibility for state adoption subsidy recipient moving from or to Ohio.

23 Department of Job and Family Services • Division of Social Services

Total Rules: 1 Original Filing Date: 11/23/2021 Date of Revised Filing: 12/13/2021 Jurisdiction Ends: 3/10/2022 Public Hearing: 12/28/2021

<u>Rule Type</u>	<u>Action</u>	<u>CSI</u>	<u>FYR</u>	<u>Rule Number</u>	<u>Rule Title</u>
------------------	---------------	------------	------------	--------------------	-------------------

Click on the rule number in blue above to view the rule in its entirety on the *Register of Ohio* website.

Amendment Revised Filing No No [5101:2-47-21](#) Title IV-E foster care maintenance (FCM) reimbursement for a child placed into a qualified residential treatment program (QRTP).

24 Department of Job and Family Services • Division of Social Services

Total Rules: 2 Original Filing Date: 1/14/2022 Date of Revised Filing: 1/14/2022 Jurisdiction Ends: 3/20/2022 Public Hearing: 2/17/2022

<u>Rule Type</u>	<u>Action</u>	<u>CSI</u>	<u>FYR</u>	<u>Rule Number</u>	<u>Rule Title</u>
Amendment	Revised Filing	Yes	No	5101:2-42-19	Requirements for the provision of independent living services to youth in custody.
Amendment	Revised Filing	No	No	5101:2-42-19.2	Requirements for provision of independent living services to young adults who have emancipated.

25 Department of Job and Family Services • Division of Social Services

Total Rules: 2 Original Filing Date: 1/3/2022 Jurisdiction Ends: 3/10/2022 Public Hearing: 2/9/2022

<u>Rule Type</u>	<u>Action</u>	<u>CSI</u>	<u>FYR</u>	<u>Rule Number</u>	<u>Rule Title</u>
Amendment	Original Filing	Yes	Yes	5101:2-5-26	Procedures for revocation, denial of initial certification or denial of recertification of a foster home certificate.
Amendment	Original Filing	No	Yes	5101:2-7-08	Alternative care arrangements.

26 Department of Job and Family Services - Unemployment Compensation •

Total Rules: 1 Original Filing Date: 12/22/2021 Jurisdiction Ends: 3/10/2022 Public Hearing: 1/27/2022

<u>Rule Type</u>	<u>Action</u>	<u>CSI</u>	<u>FYR</u>	<u>Rule Number</u>	<u>Rule Title</u>
Amendment	Original Filing	No	Yes	4141-23-03	Social security account numbers.

27 Department of Mental Health and Addiction Services •

Total Rules: 1 Original Filing Date: 11/29/2021 Date of Revised Filing: 1/3/2022 Jurisdiction Ends: 3/10/2022 Public Hearing: 12/30/2021

<u>Rule Type</u>	<u>Action</u>	<u>CSI</u>	<u>FYR</u>	<u>Rule Number</u>	<u>Rule Title</u>
Amendment	Revised Filing	No	Yes	5122-2-13	Medication practices in regional psychiatric hospitals.

28 Department of Mental Health and Addiction Services •

Total Rules: 1 Original Filing Date: 12/9/2021 Jurisdiction Ends: 3/10/2022 Public Hearing: 1/11/2022

<u>Rule Type</u>	<u>Action</u>	<u>CSI</u>	<u>FYR</u>	<u>Rule Number</u>	<u>Rule Title</u>
Amendment	Original Filing	Yes	Yes	5122-29-09	Residential and withdrawal management substance use disorder services.

29 Department of Mental Health and Addiction Services •

Total Rules: 1 Original Filing Date: 12/9/2021 Jurisdiction Ends: 3/10/2022 Public Hearing: 1/12/2022

<u>Rule Type</u>	<u>Action</u>	<u>CSI</u>	<u>FYR</u>	<u>Rule Number</u>	<u>Rule Title</u>
------------------	---------------	------------	------------	--------------------	-------------------

Click on the rule number in blue above to view the rule in its entirety on the *Register of Ohio* website.

Rescission Original Filing Yes Yes [5122-29-15.1](#) Certified peer recovery supporter.
 Total Rules: 1 Original Filing Date: 12/9/2021 Date of Revised Filing: 12/23/2021 Jurisdiction Ends: 3/10/2022 Public Hearing: 1/12/2022

Rule Type Action CSI FYR Rule Number Rule Title
 Amendment Revised Filing Yes Yes [5122-29-15](#) Peer recovery services.
 Total Rules: 1 Original Filing Date: 12/9/2021 Date of Revised Filing: 2/7/2022 Jurisdiction Ends: 3/10/2022 Public Hearing: 1/12/2022

Rule Type Action CSI FYR Rule Number Rule Title
 New Rule Revised Filing Yes No [5122-29-15.1](#) Adult, Family, and Youth Certified Peer Supporter.

30 Department of Mental Health and Addiction Services • Fiscal Administration

Total Rules: 1 Original Filing Date: 12/22/2021 Date of Revised Filing: 2/7/2022 Jurisdiction Ends: 3/10/2022 Public Hearing: 1/26/2022

Rule Type Action CSI FYR Rule Number Rule Title
 Amendment Revised Filing No Yes [5122:1-3-01](#) Financial requirements for boards.

31 Department of Rehabilitation and Correction •

Total Rules: 1 Original Filing Date: 1/4/2022 Jurisdiction Ends: 3/10/2022 Public Hearing:

Rule Type Action CSI FYR Rule Number Rule Title
 Amendment Original Filing No No [5120-9-17](#) Incoming mail.

32 Department of Rehabilitation and Correction • Division of Parole and Community Services

Total Rules: 5 Original Filing Date: 1/19/2022 Jurisdiction Ends: 3/25/2022 Public Hearing: 2/23/2022

Rule Type Action CSI FYR Rule Number Rule Title
 Amendment Original Filing No Yes [5120:1-5-01](#) Glossary of terms.

Amendment Original Filing No Yes [5120:1-5-03](#) Eligibility for subsidies; requirements for comprehensive plan and grant application for corrections services.

Amendment Original Filing No Yes [5120:1-5-05](#) Program monitoring and evaluation of participating counties.

Amendment Original Filing No Yes [5120:1-5-06](#) Subsidy awards to municipal corporations and counties.

Amendment Original Filing No Yes [5120:1-5-07](#) Reduction in local funding prohibited.

33 Department of Taxation •

Total Rules: 1 Original Filing Date: 12/29/2021 Jurisdiction Ends: 3/10/2022 Public Hearing:

Rule Type Action CSI FYR Rule Number Rule Title
 Amendment Original Filing No Yes [5703-1-06](#) Certification of exempt facilities under sections 5709.20 to 5709.27 of the Revised Code.

Click on the rule number in blue above to view the rule in its entirety on the *Register of Ohio* website.

34 Medical Marijuana Control Program • Definitions

Total Rules: 1 Original Filing Date: 12/14/2021

Jurisdiction Ends: 3/10/2022 Public Hearing: 1/18/2022

<u>Rule Type</u>	<u>Action</u>	<u>CSI</u>	<u>FYR</u>	<u>Rule Number</u>	<u>Rule Title</u>
Amendment	Original Filing	Yes	No	3796:1-1-01	Definitions.

35 Medical Marijuana Control Program • Medical Marijuana Cultivators

Total Rules: 2 Original Filing Date: 12/14/2021

Jurisdiction Ends: 3/10/2022 Public Hearing: 1/18/2022

<u>Rule Type</u>	<u>Action</u>	<u>CSI</u>	<u>FYR</u>	<u>Rule Number</u>	<u>Rule Title</u>
Amendment	Original Filing	Yes	No	3796:2-2-02	Cultivator and plant-only processor packaging and labeling.
Amendment	Original Filing	Yes	No	3796:2-2-06	Laboratory testing.

36 Medical Marijuana Control Program • Processors

Total Rules: 3 Original Filing Date: 12/14/2021

Jurisdiction Ends: 3/10/2022 Public Hearing: 1/18/2022

<u>Rule Type</u>	<u>Action</u>	<u>CSI</u>	<u>FYR</u>	<u>Rule Number</u>	<u>Rule Title</u>
Amendment	Original Filing	Yes	No	3796:3-2-02	Processor packaging and labeling.
Amendment	Original Filing	Yes	No	3796:3-2-04	Processor inventory control and storage.
Amendment	Original Filing	Yes	No	3796:3-2-06	Laboratory testing.

37 Medical Marijuana Control Program • Testing Laboratories

Total Rules: 2 Original Filing Date: 12/14/2021

Jurisdiction Ends: 3/10/2022 Public Hearing: 1/18/2022

<u>Rule Type</u>	<u>Action</u>	<u>CSI</u>	<u>FYR</u>	<u>Rule Number</u>	<u>Rule Title</u>
Amendment	Original Filing	Yes	No	3796:4-2-04	Testing laboratory analysis requirements.
Amendment	Original Filing	Yes	No	3796:4-2-05	Testing laboratory reporting.

38 Ohio Casino Control Commission •

Total Rules: 50 Original Filing Date: 1/3/2022

Jurisdiction Ends: 3/10/2022 Public Hearing: 2/4/2022

<u>Rule Type</u>	<u>Action</u>	<u>CSI</u>	<u>FYR</u>	<u>Rule Number</u>	<u>Rule Title</u>
Amendment	Original Filing	Yes	Yes	3772-11-01	Definitions.
New Rule	Original Filing	Yes	No	3772-11-02	Approval of table games and publication of table game information.
Rescission	Original Filing	Yes	Yes	3772-11-03	Approval of table games.
New Rule	Original Filing	Yes	No	3772-11-03	Table game supervision.
Rescission	Original Filing	Yes	Yes	3772-11-04	Prohibition on table game play by gaming-related vendors.

JOINT COMMITTEE ON AGENCY RULE REVIEW

3/8/2022 - 11:00 AM

Senate Finance Hearing Room (Finan Hearing Room)

FINAL REGULAR AGENDA

FINAL REGULAR AGENDA

New Rule	Original Filing	Yes	No	3772-11-04	Minimum and maximum table game wagers.
Rescission	Original Filing	Yes	Yes	3772-11-05	Purchase or lease from authorized gaming-related vendors.
New Rule	Original Filing	Yes	No	3772-11-05	Dealer hand clearing.
Rescission	Original Filing	Yes	Yes	3772-11-06	Transportation of table game mechanisms and gaming chips to and from a casino facility.
New Rule	Original Filing	Yes	No	3772-11-06	Table inventory.
Rescission	Original Filing	Yes	Yes	3772-11-07	Receipt of gaming chips from manufacturer.
New Rule	Original Filing	Yes	No	3772-11-07	Patron exchanges.
Rescission	Original Filing	Yes	Yes	3772-11-08	Compliance with law; prohibited activities.
New Rule	Original Filing	Yes	No	3772-11-08	Opening of gaming tables.
Rescission	Original Filing	Yes	Yes	3772-11-09	Publication of rules and payoff schedules for all permitted games.
New Rule	Original Filing	Yes	No	3772-11-09	Closing of gaming tables.
New Rule	Original Filing	Yes	No	3772-11-10	Gaming table chip fills.
Rescission	Original Filing	Yes	Yes	3772-11-11	Chip specifications.
New Rule	Original Filing	Yes	No	3772-11-11	Gaming table chip credits.
Rescission	Original Filing	Yes	Yes	3772-11-12	Submission of chips for review and approval.
New Rule	Original Filing	Yes	No	3772-11-12	Table game secondary procedures.
Rescission	Original Filing	Yes	Yes	3772-11-13	Primary and secondary sets of gaming chips.
New Rule	Original Filing	Yes	No	3772-11-13	Table games inspection and maintenance.
Rescission	Original Filing	Yes	Yes	3772-11-14	Exchange of value chips or non-value chips.
New Rule	Original Filing	Yes	No	3772-11-14	Progressive table games.
Rescission	Original Filing	Yes	Yes	3772-11-15	Inventory of chips.
New Rule	Original Filing	Yes	No	3772-11-15	Instructional table games.
Rescission	Original Filing	Yes	Yes	3772-11-16	Destruction of chips.
New Rule	Original Filing	Yes	No	3772-11-16	Required gaming chips.
Rescission	Original Filing	Yes	Yes	3772-11-17	Counterfeit chips.
New Rule	Original Filing	Yes	No	3772-11-17	Chip specifications.
New Rule	Original Filing	Yes	No	3772-11-18	Transportation of table game mechanisms and gaming chips.
Rescission	Original Filing	Yes	Yes	3772-11-19	Proving chips.
New Rule	Original Filing	Yes	No	3772-11-19	Receipt, inventory, and storage of gaming chips.
Rescission	Original Filing	Yes	Yes	3772-11-20	Dice and card specifications.

Click on the rule number in blue above to view the rule in its entirety on the *Register of Ohio* website.

New Rule	Original Filing	Yes	No	3772-11-20	Exchange of gaming chips.
Rescission	Original Filing	Yes	Yes	3772-11-21	Dice and card receipt, storage, and use.
New Rule	Original Filing	Yes	No	3772-11-21	Proving chips.
Rescission	Original Filing	Yes	Yes	3772-11-22	Inspection of dice and cards before use.
New Rule	Original Filing	Yes	No	3772-11-22	Destruction of gaming chips.
Rescission	Original Filing	Yes	Yes	3772-11-23	Cancellation and destruction of dice and cards.
New Rule	Original Filing	Yes	No	3772-11-23	Card and dice specifications.
Rescission	Original Filing	Yes	Yes	3772-11-24	Mandatory table game count procedure.
New Rule	Original Filing	Yes	No	3772-11-24	Card and dice receipt, storage, and use.
Rescission	Original Filing	Yes	Yes	3772-11-25	Patron exchanges.
New Rule	Original Filing	Yes	No	3772-11-25	Inspection of cards and dice before use.
Rescission	Original Filing	Yes	Yes	3772-11-26	Table inventory.
New Rule	Original Filing	Yes	No	3772-11-26	Cancellation and destruction of cards and dice.
Rescission	Original Filing	Yes	Yes	3772-11-27	Opening of gaming tables.
New Rule	Original Filing	Yes	No	3772-11-27	Table game layouts.

39 Ohio Casino Control Commission •

Total Rules: 13 Original Filing Date: 1/3/2022

Jurisdiction Ends: 3/10/2022 Public Hearing: 2/4/2022

<u>Rule Type</u>	<u>Action</u>	<u>CSI</u>	<u>FYR</u>	<u>Rule Number</u>	<u>Rule Title</u>
Rescission	Original Filing	Yes	Yes	3772-11-28	Closing of gaming tables.
New Rule	Original Filing	Yes	No	3772-11-28	Prohibited activities.
Rescission	Original Filing	Yes	Yes	3772-11-29	Payout for progressive table games.
Rescission	Original Filing	Yes	Yes	3772-11-31	Automated table fills.
Rescission	Original Filing	Yes	Yes	3772-11-32	Table game fill and credit procedures.
Rescission	Original Filing	Yes	Yes	3772-11-33	Automated table credits.
Rescission	Original Filing	Yes	Yes	3772-11-34	Table game layouts.
Rescission	Original Filing	Yes	Yes	3772-11-35	Table game pit areas and supervision.
Rescission	Original Filing	Yes	Yes	3772-11-36	Instructional table games offered to public.
Rescission	Original Filing	Yes	Yes	3772-11-37	Minimum and maximum table game wagers.
Rescission	Original Filing	Yes	Yes	3772-11-38	Dealer and boxperson hand clearing.
Rescission	Original Filing	Yes	Yes	3772-11-39	Table games inspection and maintenance.

Click on the rule number in blue above to view the rule in its entirety on the *Register of Ohio* website.

Amendment Original Filing Yes No [3772-14-01](#) Player against player contests.

40 Ohio Department of Medicaid • Eligibility

Total Rules: 1 Original Filing Date: 12/2/2021 Jurisdiction Ends: 3/10/2022 Public Hearing:

<u>Rule Type</u>	<u>Action</u>	<u>CSI</u>	<u>FYR</u>	<u>Rule Number</u>	<u>Rule Title</u>
Amendment	Original Filing	No	Yes	5160:1-1-01	Medicaid: definitions.

41 Ohio Department of Medicaid • Eligibility

Total Rules: 2 Original Filing Date: 1/13/2022 Jurisdiction Ends: 3/19/2022 Public Hearing:

<u>Rule Type</u>	<u>Action</u>	<u>CSI</u>	<u>FYR</u>	<u>Rule Number</u>	<u>Rule Title</u>
Rescission	Original Filing	No	Yes	5160:1-3-05.1	Medicaid: resource requirement.
New Rule	Original Filing	No	No	5160:1-3-05.1	Medicaid: resource requirement.

42 Ohio Department of Medicaid •

Total Rules: 1 Original Filing Date: 4/26/2021 Date of Refiled Filing: 2/7/2022 Jurisdiction Ends: 3/9/2022 Public Hearing: 5/27/2021

<u>Rule Type</u>	<u>Action</u>	<u>CSI</u>	<u>FYR</u>	<u>Rule Number</u>	<u>Rule Title</u>
New Rule	Refiled Filing	Yes	No	5160-1-42	Provider credentialing.

43 Ohio Department of Medicaid •

Total Rules: 1 Original Filing Date: 1/14/2022 Date of Revised Filing: 2/16/2022 Jurisdiction Ends: 3/20/2022 Public Hearing: 2/14/2022

<u>Rule Type</u>	<u>Action</u>	<u>CSI</u>	<u>FYR</u>	<u>Rule Number</u>	<u>Rule Title</u>
Amendment	Revised Filing	Yes	Yes	5160-5-01	Dental services.

44 Ohio Department of Medicaid •

Total Rules: 2 Original Filing Date: 1/14/2022 Jurisdiction Ends: 3/20/2022 Public Hearing: 2/14/2022

<u>Rule Type</u>	<u>Action</u>	<u>CSI</u>	<u>FYR</u>	<u>Rule Number</u>	<u>Rule Title</u>
Amendment	Original Filing	No	Yes	5160-41-05	Waiting lists for home and community-based services administered by the Ohio department of developmental disabilities.
Amendment	Original Filing	No	Yes	5160-41-08	Free choice of provider requirements for medicaid home and community-based services programs administered by the Ohio department of developmental disabilities.

45 Ohio Environmental Protection Agency •

Total Rules: 1 Original Filing Date: 11/29/2021 Date of Refiled Filing: 2/14/2022 Jurisdiction Ends: 3/16/2022 Public Hearing: 1/3/2022

Click on the rule number in blue above to view the rule in its entirety on the *Register of Ohio* website.

<u>Rule Type</u>	<u>Action</u>	<u>CSI</u>	<u>FYR</u>	<u>Rule Number</u>	<u>Rule Title</u>
Amendment	Refiled Filing	Yes	Yes	3745-21-09	Control of emissions of volatile organic compounds from stationary sources and perchloroethylene from dry cleaning facilities.

46 Ohio Environmental Protection Agency •

Total Rules: 6 Original Filing Date: 1/5/2022 Date of Refiled Filing: 2/14/2022 Jurisdiction Ends: 3/16/2022 Public Hearing: 2/10/2022

<u>Rule Type</u>	<u>Action</u>	<u>CSI</u>	<u>FYR</u>	<u>Rule Number</u>	<u>Rule Title</u>
Rescission	Refiled Filing	Yes	Yes	3745-81-14	Maximum contaminant levels for microbiological contaminants.
Rescission	Refiled Filing	Yes	Yes	3745-81-21	Coliform monitoring requirements.
Amendment	Refiled Filing	Yes	Yes	3745-81-50	Revised total coliform rule - general monitoring requirements.
Amendment	Refiled Filing	Yes	Yes	3745-81-51	Revised total coliform rule - routine monitoring requirements.
Amendment	Refiled Filing	Yes	Yes	3745-81-52	Revised total coliform rule - repeat monitoring and E. coli requirements.
Amendment	Refiled Filing	Yes	Yes	3745-81-55	Revised total coliform rule - reporting and recordkeeping.

47 Ohio Environmental Protection Agency •

Total Rules: 1 Original Filing Date: 1/4/2022 Date of Refiled Filing: 2/14/2022 Jurisdiction Ends: 3/16/2022 Public Hearing: 2/8/2022

<u>Rule Type</u>	<u>Action</u>	<u>CSI</u>	<u>FYR</u>	<u>Rule Number</u>	<u>Rule Title</u>
Amendment	Refiled Filing	Yes	Yes	3745-85-01	Contingency plans.

48 Ohio Housing Finance Agency •

Total Rules: 1 Original Filing Date: 12/14/2021 Jurisdiction Ends: 3/10/2022 Public Hearing: 1/20/2022

<u>Rule Type</u>	<u>Action</u>	<u>CSI</u>	<u>FYR</u>	<u>Rule Number</u>	<u>Rule Title</u>
Amendment	Original Filing	No	Yes	175-11-01	D.O.L.L.A.R. deed program model forms.

49 Ohio Occupational Therapy, Physical Therapy, and Athletic Trainers Board •

Total Rules: 1 Original Filing Date: 12/23/2021 Date of Revised Filing: 2/7/2022 Jurisdiction Ends: 3/10/2022 Public Hearing: 1/26/2022

<u>Rule Type</u>	<u>Action</u>	<u>CSI</u>	<u>FYR</u>	<u>Rule Number</u>	<u>Rule Title</u>
Amendment	Revised Filing	Yes	No	4755-64-01	Ethical and professional conduct.

50 Ohio Speech and Hearing Professionals Board •

Total Rules: 2 Original Filing Date: 12/21/2021 Jurisdiction Ends: 3/10/2022 Public Hearing: 1/31/2022

<u>Rule Type</u>	<u>Action</u>	<u>CSI</u>	<u>FYR</u>	<u>Rule Number</u>	<u>Rule Title</u>
Amendment	Original Filing	Yes	Yes	4753-3-10	Exempt practice; renewal.

Amendment Original Filing Yes Yes [4753-7-02](#) Supervision requirements; aides.

51 Ohio Speech and Hearing Professionals Board •

Total Rules: 2 Original Filing Date: 12/30/2021 Jurisdiction Ends: 3/10/2022 Public Hearing: 1/31/2022

<u>Rule Type</u>	<u>Action</u>	<u>CSI</u>	<u>FYR</u>	<u>Rule Number</u>	<u>Rule Title</u>
Amendment	Original Filing	Yes	Yes	4753-3-10	Exempt practice; renewal.
Amendment	Original Filing	Yes	Yes	4753-7-02	Supervision requirements; aides.

52 Opportunities for Ohioans with Disabilities •

Total Rules: 2 Original Filing Date: 1/10/2022 Jurisdiction Ends: 3/16/2022 Public Hearing: 2/10/2022

<u>Rule Type</u>	<u>Action</u>	<u>CSI</u>	<u>FYR</u>	<u>Rule Number</u>	<u>Rule Title</u>
Rescission	Original Filing	Yes	Yes	3304-2-53	Qualifications and standards for service providers and vendors.
New Rule	Original Filing	Yes	No	3304-2-53	Qualifications and standards for service providers and vendors.

53 Secretary of State •

Total Rules: 6 Original Filing Date: 1/10/2022 Jurisdiction Ends: 3/16/2022 Public Hearing: 2/11/2022

<u>Rule Type</u>	<u>Action</u>	<u>CSI</u>	<u>FYR</u>	<u>Rule Number</u>	<u>Rule Title</u>
Amendment	Original Filing	No	Yes	111-1-01	Public notice of the adoption, amendment, or rescission of rules.
Amendment	Original Filing	No	Yes	111-1-02	Confidential personal information systems.
Rescission	Original Filing	No	Yes	111-1-03	Safe at home address confidentiality program.
Rescission	Original Filing	No	Yes	111-1-04	Safe at home address confidentiality program application.
Amendment	Original Filing	No	Yes	111-1-05	Safe at home address confidentiality program participant certification and renewal.
Amendment	Original Filing	No	Yes	111-1-06	Service of process.

54 Secretary of State • Elections

Total Rules: 7 Original Filing Date: 1/10/2022 Jurisdiction Ends: 3/16/2022 Public Hearing:

<u>Rule Type</u>	<u>Action</u>	<u>CSI</u>	<u>FYR</u>	<u>Rule Number</u>	<u>Rule Title</u>
Amendment	Original Filing	No	Yes	111:3-5-01	Scope of rules.
Amendment	Original Filing	No	Yes	111:3-5-02	Submission of plan.
Amendment	Original Filing	No	Yes	111:3-5-03	Registration opportunities.
Amendment	Original Filing	No	Yes	111:3-5-04	Employees.
Amendment	Original Filing	No	Yes	111:3-5-05	Transmittal of forms.
Amendment	Original Filing	No	Yes	111:3-5-06	Registration and transmittal forms to be prescribed.

Click on the rule number in blue above to view the rule in its entirety on the *Register of Ohio* website.

Amendment Original Filing No Yes [111:3-5-07](#) Voter registration - bureau of motor vehicles.

55 Secretary of State • Elections

Total Rules: 38 Original Filing Date: 1/10/2022 Jurisdiction Ends: 3/16/2022 Public Hearing: 2/11/2022

<u>Rule Type</u>	<u>Action</u>	<u>CSI</u>	<u>FYR</u>	<u>Rule Number</u>	<u>Rule Title</u>
Amendment	Original Filing	No	Yes	111:3-1-01	Issuance of directives.
Amendment	Original Filing	No	Yes	111:3-2-01	Definitions.
Amendment	Original Filing	No	Yes	111:3-2-02	Placing a board of elections under official oversight.
Amendment	Original Filing	No	Yes	111:3-2-03	Period of oversight.
Amendment	Original Filing	No	Yes	111:3-2-04	Terms of oversight.
Amendment	Original Filing	No	Yes	111:3-2-05	Transition from oversight.
Amendment	Original Filing	No	Yes	111:3-3-02	Eligibility.
Amendment	Original Filing	No	Yes	111:3-3-04	Repayment of loans.
Amendment	Original Filing	No	Yes	111:3-4-01	Converting voter registration applications into electronic files.
Amendment	Original Filing	No	Yes	111:3-4-02	Entering voter registration records into the statewide voter registration database on an expedited basis.
Amendment	Original Filing	No	Yes	111:3-4-03	Removing canceled voter registration records.
Amendment	Original Filing	No	Yes	111:3-4-04	Persons authorized to update statewide voter registration database.
Amendment	Original Filing	No	Yes	111:3-4-05	Conducting annual audits of the statewide voter registration database.
Amendment	Original Filing	No	Yes	111:3-4-06	Data sharing.
Rescission	Original Filing	No	Yes	111:3-4-07	Safe at home confidential voter registration record.
Amendment	Original Filing	No	Yes	111:3-6-02	Definitions.
Amendment	Original Filing	No	Yes	111:3-6-03	Processing voter registration applications by designated agencies, other registration agencies and deputy registrars of motor vehicles.
Amendment	Original Filing	No	Yes	111:3-6-04	Processing voter registration applications received electronically from designated agencies, other registration agencies and deputy registrars of motor vehicles by the secretary of state.
Amendment	Original Filing	No	Yes	111:3-6-05	Training for agencies conducting voter registration activities.
Amendment	Original Filing	No	Yes	111:3-6-06	Training for boards of elections.
Amendment	Original Filing	No	Yes	111:3-6-07	Processing voter registration applications received from the secretary of state electronically and from designated agencies, other registration agencies and deputy registrars of motor vehicles, by boards of elections.

Click on the rule number in blue above to view the rule in its entirety on the *Register of Ohio* website.

JOINT COMMITTEE ON AGENCY RULE REVIEW

3/8/2022 - 11:00 AM

Senate Finance Hearing Room (Finan Hearing Room)

FINAL REGULAR AGENDA

FINAL REGULAR AGENDA

Amendment	Original Filing	No	Yes	111:3-6-08	Prohibitions.
Amendment	Original Filing	No	Yes	111:3-7-01	Compensation of precinct election officials.
Amendment	Original Filing	No	Yes	111:3-7-02	Changes in locations of precinct polling places and notification to the secretary of state.
Amendment	Original Filing	No	Yes	111:3-8-01	Notice of meetings of Ohio ballot board.
Amendment	Original Filing	No	Yes	111:3-9-01	Notice of meetings.
Amendment	Original Filing	No	Yes	111:3-9-02	Application requirements; generally.
Amendment	Original Filing	No	Yes	111:3-9-03	Application fee.
Amendment	Original Filing	No	Yes	111:3-9-06	Demonstration and approval of equipment; generally.
Amendment	Original Filing	No	Yes	111:3-9-07	Demonstration procedure.
Amendment	Original Filing	No	Yes	111:3-9-08	Certification; mandatory requirements.
Amendment	Original Filing	No	Yes	111:3-9-10	Bond.
Amendment	Original Filing	No	Yes	111:3-9-11	Enhancements and significant adjustments; duties.
Rescission	Original Filing	No	Yes	111:3-9-12	Updated manuals; duties.
Amendment	Original Filing	No	Yes	111:3-9-14	Re-examination; periodic.
Amendment	Original Filing	No	Yes	111:3-9-16	Withdrawal of certification; procedure.
Amendment	Original Filing	No	Yes	111:3-9-17	Reconsideration hearing; procedure.
Amendment	Original Filing	No	Yes	111:3-9-18	Standards for voter verified paper audit trail.

Total Rules: 1 Original Filing Date: 1/10/2022 Date of Revised Filing: 2/7/2022 Jurisdiction Ends: 3/16/2022 Public Hearing: 2/11/2022

<u>Rule Type</u>	<u>Action</u>	<u>CSI</u>	<u>FYR</u>	<u>Rule Number</u>	<u>Rule Title</u>
Rescission	Revised Filing	No	Yes	111:3-9-05	Operations manual; submission.

56 State Board of Pharmacy • Distributors of Dangerous Drugs

Total Rules: 2 Original Filing Date: 1/12/2022 Jurisdiction Ends: 3/18/2022 Public Hearing: 2/18/2022

<u>Rule Type</u>	<u>Action</u>	<u>CSI</u>	<u>FYR</u>	<u>Rule Number</u>	<u>Rule Title</u>
Amendment	Original Filing	Yes	Yes	4729:6-2-01	Responsible person - drug distributor.
Amendment	Original Filing	Yes	Yes	4729:6-4-01	Disciplinary actions.

Total Rules: 1 Original Filing Date: 1/12/2022 Date of Revised Filing: 1/21/2022 Jurisdiction Ends: 3/18/2022 Public Hearing: 2/18/2022

<u>Rule Type</u>	<u>Action</u>	<u>CSI</u>	<u>FYR</u>	<u>Rule Number</u>	<u>Rule Title</u>
Amendment	Revised Filing	Yes	Yes	4729:6-1-01	Definitions - distributors of dangerous drugs.

57 State Board of Pharmacy • Pharmacists

Click on the rule number in blue above to view the rule in its entirety on the *Register of Ohio* website.

JOINT COMMITTEE ON AGENCY RULE REVIEW

3/8/2022 - 11:00 AM

Senate Finance Hearing Room (Finan Hearing Room)

FINAL REGULAR AGENDA

FINAL REGULAR AGENDA

Total Rules: 4 Original Filing Date: 1/12/2022 Jurisdiction Ends: 3/18/2022 Public Hearing: 2/18/2022

<u>Rule Type</u>	<u>Action</u>	<u>CSI</u>	<u>FYR</u>	<u>Rule Number</u>	<u>Rule Title</u>
Amendment	Original Filing	Yes	Yes	4729:1-2-02	Criteria for licensure by reciprocity.
New Rule	Original Filing	Yes	No	4729:1-3-07	Dispensing nicotine replacement therapy by pharmacists.
Amendment	Original Filing	Yes	Yes	4729:1-4-01	Disciplinary actions.
Amendment	Original Filing	Yes	Yes	4729:1-4-02	Duty to report.

Total Rules: 1 Original Filing Date: 1/12/2022 Date of Revised Filing: 1/21/2022 Jurisdiction Ends: 3/18/2022 Public Hearing: 2/18/2022

<u>Rule Type</u>	<u>Action</u>	<u>CSI</u>	<u>FYR</u>	<u>Rule Number</u>	<u>Rule Title</u>
Amendment	Revised Filing	Yes	Yes	4729:1-1-01	Definitions - pharmacists.

58 State Board of Pharmacy • Pharmacy Interns

Total Rules: 2 Original Filing Date: 1/12/2022 Jurisdiction Ends: 3/18/2022 Public Hearing: 2/18/2022

<u>Rule Type</u>	<u>Action</u>	<u>CSI</u>	<u>FYR</u>	<u>Rule Number</u>	<u>Rule Title</u>
Amendment	Original Filing	Yes	Yes	4729:2-4-01	Disciplinary actions.
Amendment	Original Filing	Yes	Yes	4729:2-4-02	Duty to report.

Total Rules: 1 Original Filing Date: 1/12/2022 Date of Revised Filing: 1/21/2022 Jurisdiction Ends: 3/18/2022 Public Hearing: 2/18/2022

<u>Rule Type</u>	<u>Action</u>	<u>CSI</u>	<u>FYR</u>	<u>Rule Number</u>	<u>Rule Title</u>
Amendment	Revised Filing	Yes	Yes	4729:2-1-01	Definitions - pharmacy interns.

59 State Board of Pharmacy • Pharmacy Technicians

Total Rules: 2 Original Filing Date: 4/27/2021 Date of Refiled Filing: 2/11/2022 Jurisdiction Ends: 3/13/2022 Public Hearing: 6/3/2021

<u>Rule Type</u>	<u>Action</u>	<u>CSI</u>	<u>FYR</u>	<u>Rule Number</u>	<u>Rule Title</u>
Amendment	Refiled Filing	Yes	Yes	4729:3-2-01	Registration procedures.
Amendment	Refiled Filing	Yes	Yes	4729:3-2-03	Renewal procedures.

60 State Board of Pharmacy • Pharmacy Technicians

Total Rules: 1 Original Filing Date: 1/12/2022 Jurisdiction Ends: 3/18/2022 Public Hearing: 2/18/2022

<u>Rule Type</u>	<u>Action</u>	<u>CSI</u>	<u>FYR</u>	<u>Rule Number</u>	<u>Rule Title</u>
Amendment	Original Filing	Yes	Yes	4729:3-4-02	Duty to report.

Total Rules: 1 Original Filing Date: 1/12/2022 Date of Revised Filing: 1/21/2022 Jurisdiction Ends: 3/18/2022 Public Hearing: 2/18/2022

<u>Rule Type</u>	<u>Action</u>	<u>CSI</u>	<u>FYR</u>	<u>Rule Number</u>	<u>Rule Title</u>
------------------	---------------	------------	------------	--------------------	-------------------

Click on the rule number in blue above to view the rule in its entirety on the *Register of Ohio* website.

Amendment Revised Filing Yes Yes [4729:3-4-01](#) Disciplinary actions.

61 State Board of Pharmacy •

Total Rules: 1 Original Filing Date: 1/12/2022 Date of Revised Filing: 2/7/2022 Jurisdiction Ends: 3/18/2022 Public Hearing: 2/18/2022

<u>Rule Type</u>	<u>Action</u>	<u>CSI</u>	<u>FYR</u>	<u>Rule Number</u>	<u>Rule Title</u>
New Rule	Revised Filing	Yes	No	4729-3-01	Disqualifying offenses.

62 State Board of Pharmacy • Terminal Distributors of Dangerous Drugs

Total Rules: 3 Original Filing Date: 1/12/2022 Jurisdiction Ends: 3/18/2022 Public Hearing: 2/18/2022

<u>Rule Type</u>	<u>Action</u>	<u>CSI</u>	<u>FYR</u>	<u>Rule Number</u>	<u>Rule Title</u>
Amendment	Original Filing	Yes	Yes	4729:5-2-01	Responsible person - terminal distributor.
Amendment	Original Filing	Yes	Yes	4729:5-4-01	Disciplinary actions.
Amendment	Original Filing	Yes	Yes	4729:5-21-02	Personally furnishing dangerous drugs from an opioid treatment program.

Total Rules: 1 Original Filing Date: 1/12/2022 Date of Revised Filing: 1/21/2022 Jurisdiction Ends: 3/18/2022 Public Hearing: 2/18/2022

<u>Rule Type</u>	<u>Action</u>	<u>CSI</u>	<u>FYR</u>	<u>Rule Number</u>	<u>Rule Title</u>
Amendment	Revised Filing	Yes	Yes	4729:5-1-01	Definitions - terminal distributors of dangerous drugs.

63 State Board of Psychology •

Total Rules: 4 Original Filing Date: 12/21/2021 Jurisdiction Ends: 3/10/2022 Public Hearing: 1/28/2022

<u>Rule Type</u>	<u>Action</u>	<u>CSI</u>	<u>FYR</u>	<u>Rule Number</u>	<u>Rule Title</u>
Amendment	Original Filing	Yes	No	4732-9-01	Requirements for admission to the examination for a psychologist license.
Amendment	Original Filing	Yes	No	4732-9-02	Requirements for admission to the examination for a school psychologist license.
Amendment	Original Filing	Yes	No	4732-13-03	Supervision definitions.
Amendment	Original Filing	Yes	No	4732-17-01	General rules of professional conduct pursuant to section 4732.17 of the Revised Code.

64 State Board of Psychology - Certified Ohio Behavior Analysts •

Total Rules: 3 Original Filing Date: 12/21/2021 Jurisdiction Ends: 3/10/2022 Public Hearing: 1/28/2022

<u>Rule Type</u>	<u>Action</u>	<u>CSI</u>	<u>FYR</u>	<u>Rule Number</u>	<u>Rule Title</u>
Amendment	Original Filing	Yes	No	4783-4-01	Requirements for certification as a certified Ohio behavior analyst.
Amendment	Original Filing	Yes	No	4783-6-02	Requirements pertaining to supervision.
Amendment	Original Filing	Yes	No	4783-7-01	General rules of professional conduct pursuant to section 4783.09 of the Revised Code.

65 State Cosmetology and Barber Board •

Total Rules: 1 Original Filing Date: 12/28/2021 Jurisdiction Ends: 3/10/2022 Public Hearing: 1/31/2022

<u>Rule Type</u>	<u>Action</u>	<u>CSI</u>	<u>FYR</u>	<u>Rule Number</u>	<u>Rule Title</u>
Amendment	Original Filing	Yes	No	4713-3-03	School layout.

66 State Cosmetology and Barber Board •

Total Rules: 3 Original Filing Date: 12/28/2021 Jurisdiction Ends: 3/10/2022 Public Hearing: 1/31/2022

<u>Rule Type</u>	<u>Action</u>	<u>CSI</u>	<u>FYR</u>	<u>Rule Number</u>	<u>Rule Title</u>
Amendment	Original Filing	Yes	Yes	4713-5-13	Transfer procedure.
Amendment	Original Filing	Yes	Yes	4713-5-21	Instructor limitations.
Amendment	Original Filing	Yes	Yes	4713-5-28	Attire for applicants taking examinations at the board.

67 State Cosmetology and Barber Board •

Total Rules: 2 Original Filing Date: 12/28/2021 Jurisdiction Ends: 3/10/2022 Public Hearing: 1/31/2022

<u>Rule Type</u>	<u>Action</u>	<u>CSI</u>	<u>FYR</u>	<u>Rule Number</u>	<u>Rule Title</u>
Amendment	Original Filing	Yes	Yes	4713-7-01	Processing of applications for licensing and examination.
Amendment	Original Filing	Yes	Yes	4713-7-11	Temporary pre-examination work permit.

68 State Cosmetology and Barber Board •

Total Rules: 3 Original Filing Date: 12/28/2021 Jurisdiction Ends: 3/10/2022 Public Hearing: 1/31/2022

<u>Rule Type</u>	<u>Action</u>	<u>CSI</u>	<u>FYR</u>	<u>Rule Number</u>	<u>Rule Title</u>
Amendment	Original Filing	Yes	No	4713-11-05	Restrooms.
Amendment	Original Filing	Yes	Yes	4713-11-08	Residential salons and barber shops.
Amendment	Original Filing	Yes	Yes	4713-11-13	Temporary special occasion work permit.

69 State Cosmetology and Barber Board •

Total Rules: 1 Original Filing Date: 12/28/2021 Jurisdiction Ends: 3/10/2022 Public Hearing: 1/31/2022

<u>Rule Type</u>	<u>Action</u>	<u>CSI</u>	<u>FYR</u>	<u>Rule Number</u>	<u>Rule Title</u>
Amendment	Original Filing	Yes	No	4713-15-11	Proper laundering methods.

70 State Cosmetology and Barber Board •

Total Rules: 1 Original Filing Date: 12/28/2021 Jurisdiction Ends: 3/10/2022 Public Hearing: 1/31/2022

<u>Rule Type</u>	<u>Action</u>	<u>CSI</u>	<u>FYR</u>	<u>Rule Number</u>	<u>Rule Title</u>
------------------	---------------	------------	------------	--------------------	-------------------

Click on the rule number in blue above to view the rule in its entirety on the *Register of Ohio* website.

Amendment Original Filing Yes No [4713-19-08](#) Resident tanning facilities.

71 State Cosmetology and Barber Board •

Total Rules: 1 Original Filing Date: 12/28/2021 Jurisdiction Ends: 3/10/2022 Public Hearing: 1/31/2022

Rule Type Action CSI FYR Rule Number Rule Title

Amendment Original Filing Yes Yes [4713-21-09](#) Criteria for continuing education: courses, course instructors and eligible offering entities to be: approved, denied approval, withdrawn, revoked or suspended.

72 State Cosmetology and Barber Board •

Total Rules: 1 Original Filing Date: 12/28/2021 Jurisdiction Ends: 3/10/2022 Public Hearing: 1/31/2022

Rule Type Action CSI FYR Rule Number Rule Title

New Rule Original Filing Yes No [4713-1-18](#) Boutique services registration education.

73 State Cosmetology and Barber Board •

Total Rules: 1 Original Filing Date: 12/28/2021 Jurisdiction Ends: 3/10/2022 Public Hearing: 1/31/2022

Rule Type Action CSI FYR Rule Number Rule Title

New Rule Original Filing Yes No [4713-8-12](#) Cosmetic therapy.

74 State Dental Board •

Total Rules: 3 Original Filing Date: 12/2/2021 Jurisdiction Ends: 3/10/2022 Public Hearing: 1/11/2022

Rule Type Action CSI FYR Rule Number Rule Title

Amendment Original Filing Yes Yes [4715-8-02](#) Sponsors of continuing education.

Amendment Original Filing Yes Yes [4715-8-03](#) Standards for approval of biennial sponsors.

Amendment Original Filing Yes Yes [4715-8-04](#) Continuing education requirements for renewal or reinstatement.

75 State Veterinary Medical Licensing Board •

Total Rules: 3 Original Filing Date: 12/3/2021 Jurisdiction Ends: 3/10/2022 Public Hearing: 1/12/2022

Rule Type Action CSI FYR Rule Number Rule Title

Amendment Original Filing Yes No [4741-1-01](#) Animal technician duties, registration and continuing education requirements.

Amendment Original Filing Yes Yes [4741-1-11](#) Form and content of continuing education hours.

Amendment Original Filing Yes Yes [4741-1-21](#) Recordkeeping.

76 State Veterinary Medical Licensing Board •

Total Rules: 4 Original Filing Date: 12/3/2021 Jurisdiction Ends: 3/10/2022 Public Hearing: 1/12/2022

Click on the rule number in blue above to view the rule in its entirety on the *Register of Ohio* website.

<u>Rule Type</u>	<u>Action</u>	<u>CSI</u>	<u>FYR</u>	<u>Rule Number</u>	<u>Rule Title</u>
New Rule	Original Filing	Yes	No	4741-3-06	Purpose of the Veterinarian Student Debt Assistance Program.
New Rule	Original Filing	Yes	No	4741-3-07	Definitions.
New Rule	Original Filing	Yes	No	4741-3-08	Eligibility.
New Rule	Original Filing	Yes	No	4741-3-09	Letter of Intent.

77 State Veterinary Medical Licensing Board •

Total Rules: 1 Original Filing Date: 12/3/2021

Jurisdiction Ends: 3/10/2022 Public Hearing: 1/12/2022

<u>Rule Type</u>	<u>Action</u>	<u>CSI</u>	<u>FYR</u>	<u>Rule Number</u>	<u>Rule Title</u>
Amendment	Original Filing	Yes	Yes	4741-2-01	General provisions of a veterinary business facility license.

78 State Veterinary Medical Licensing Board •

Total Rules: 2 Original Filing Date: 12/7/2021

Jurisdiction Ends: 3/10/2022 Public Hearing: 1/12/2022

<u>Rule Type</u>	<u>Action</u>	<u>CSI</u>	<u>FYR</u>	<u>Rule Number</u>	<u>Rule Title</u>
Amendment	Original Filing	Yes	Yes	4741-1-22	Vaccination clinics.
Amendment	Original Filing	Yes	Yes	4741-2-01	General provisions of a veterinary business facility license.

To Be Refiled**79 Department of Developmental Disabilities •**

Total Rules: 2 Original Filing Date: 1/4/2022

Date of To Be Refiled: 3/3/2022

Jurisdiction Ends:

Public Hearing: 2/8/2022

<u>Rule Type</u>	<u>Action</u>	<u>CSI</u>	<u>FYR</u>	<u>Rule Number</u>	<u>Rule Title</u>
Rescission	To Be Refiled	Yes	Yes	5123-2-06	Development and implementation of behavioral support strategies.
New Rule	To Be Refiled	Yes	No	5123-2-06	Development and implementation of behavioral support strategies.

80 State Board of Pharmacy • Home Medical Equipment Service Providers

Total Rules: 3 Original Filing Date: 1/12/2022

Date of To Be Refiled: 2/18/2022

Jurisdiction Ends:

Public Hearing: 2/18/2022

<u>Rule Type</u>	<u>Action</u>	<u>CSI</u>	<u>FYR</u>	<u>Rule Number</u>	<u>Rule Title</u>
Amendment	To Be Refiled	Yes	Yes	4729:11-1-01	Definitions - home medical equipment.
Amendment	To Be Refiled	Yes	Yes	4729:11-2-02	Designated representative.
Amendment	To Be Refiled	Yes	Yes	4729:11-4-01	Disciplinary actions.

Withdrawn

81 Ohio Department of Medicaid •

Total Rules: 6 Original Filing Date: 1/25/2022 Date of Withdrawn Filing: 2/23/2022 Jurisdiction Ends: Public Hearing: 2/24/2022

<u>Rule Type</u>	<u>Action</u>	<u>CSI</u>	<u>FYR</u>	<u>Rule Number</u>	<u>Rule Title</u>
Rescission	Withdrawn Filing	Yes	Yes	5160-2-07.12	Appeals and reconsideration of departmental determinations regarding hospital inpatient and outpatient services.
Rescission	Withdrawn Filing	Yes	Yes	5160-2-07.13	Utilization control.
New Rule	Withdrawn Filing	Yes	No	5160-2-12	Appeals and reconsideration of departmental determinations regarding hospital inpatient and outpatient services.
New Rule	Withdrawn Filing	Yes	No	5160-2-13	Utilization review.
Rescission	Withdrawn Filing	Yes	Yes	5160-2-40	Pre-certification review.
New Rule	Withdrawn Filing	Yes	No	5160-2-40	Psychiatric pre-certification review.

82 Ohio Environmental Protection Agency •

Total Rules: 2 Original Filing Date: 2/16/2022 Date of Withdrawn Filing: 2/17/2022 Jurisdiction Ends: Public Hearing: 3/29/2022

<u>Rule Type</u>	<u>Action</u>	<u>CSI</u>	<u>FYR</u>	<u>Rule Number</u>	<u>Rule Title</u>
Amendment	Withdrawn Filing	Yes	Yes	3745-38-01	Definitions.
Amendment	Withdrawn Filing	Yes	Yes	3745-38-02	Requirements for general national pollutant discharge elimination system (NPDES) permits.

Article III

Attachment E

Final Adoption Notice to LSC
Director and Secretary of
State



ELECTRONIC RULE-FILING SYSTEM

FILING OF OHIO ADMINISTRATIVE RULES AND RULE-RELATED DOCUMENTS

The Honorable Frank LaRose
Secretary of State
180 E. Broad St., 16th Floor
Columbus, OH 43215

Wendy Zhan, Director
Legislative Service Commission
77 South High St., 9th Floor
Columbus, OH 43215

Larry Wolpert, Director
Joint Committee on Agency Rule Review
77 South High St., Concourse Level
Columbus, OH 43215

It is hereby confirmed that the Ohio Environmental Protection Agency **final filed** the following rule(s) pursuant to section 119.03 of the Ohio Revised Code.

Package Number: 190335
File Date and Time: 3/17/2022 9:07 AM
Confirmation Number: unavailable

FINAL

Rule Number	Type	FYR	CSI	JE Date	Eff Date	Next FYR	Tagline
3745-21-01	Amendment	Y	Y	02/02/2022	03/27/2022	11/29/2026	Definitions and incorporation by reference.
3745-21-04	Amendment	Y	Y	02/02/2022	03/27/2022	11/29/2026	Compliance time schedules.
3745-21-07	Amendment	Y	Y	02/02/2022	03/27/2022	11/29/2026	Control of emissions of organic materials from stationary sources (i.e., emissions that are not regulated by rule 3745-21-09, 3745-21-12 to 3745-21-16, or 3745-21-18 to 3745-21-29 of the Administrative Code).
3745-21-09	Amendment	Y	Y	02/02/2022	03/27/2022	11/29/2026	Control of emissions of volatile organic compounds from stationary sources and perchloroethylene from dry cleaning facilities.
3745-21-10	Amendment	Y	Y	02/02/2022	03/27/2022	11/29/2026	Compliance test methods and procedures.
3745-21-11	New	N	Y	02/02/2022	03/27/2022	11/29/2026	Reasonably available control technology studies for non-CTG sources in ozone nonattainment areas.
3745-21-15	Amendment	Y	Y	02/02/2022	03/27/2022	11/29/2026	Control of volatile organic compound emissions from wood furniture manufacturing operations.
3745-21-18	Amendment	Y	Y	02/02/2022	03/27/2022	11/29/2026	Commercial motor vehicle and mobile equipment refinishing operations.
3745-21-19	Amendment	Y	Y	02/02/2022	03/27/2022	11/29/2026	Control of volatile organic compound emissions from aerospace manufacturing and rework facilities.
3745-21-20	Amendment	Y	Y	02/02/2022	03/27/2022	11/29/2026	Control of volatile organic emissions from shipbuilding and ship repair operations (marine coatings).
3745-21-21	Amendment	Y	Y	02/02/2022	03/27/2022	11/29/2026	Storage of volatile organic liquids in fixed roof tanks and external floating roof tanks.
3745-21-22	Amendment	Y	Y	02/02/2022	03/27/2022	11/29/2026	Control of volatile organic compound emissions from offset lithographic printing and letterpress printing facilities.

Rule Number	Type	FYR	CSI	JE Date	Eff Date	Next FYR	Tagline
3745-21-23	Amendment	Y	Y	02/02/2022	03/27/2022	11/29/2026	Control of volatile organic compound emissions from industrial solvent cleaning operations.
3745-21-24	Amendment	Y	Y	02/02/2022	03/27/2022	11/29/2026	Flat wood paneling coatings.
3745-21-25	Amendment	Y	Y	02/02/2022	03/27/2022	11/29/2026	Control of VOC emissions from reinforced plastic composites production operations.
3745-21-26	Amendment	Y	Y	02/02/2022	03/27/2022	11/29/2026	Surface coating of miscellaneous metal and plastic parts.
3745-21-27	Amendment	Y	Y	02/02/2022	03/27/2022	11/29/2026	Boat manufacturing.
3745-21-28	Amendment	Y	Y	02/02/2022	03/27/2022	11/29/2026	Miscellaneous industrial adhesives and sealants.
3745-21-29	Amendment	Y	Y	02/02/2022	03/27/2022	11/29/2026	Control of volatile organic compound emissions from automobile and light-duty truck assembly coating operations, heavier vehicle assembly coating operations, and cleaning operations associated with these coating operations.

Article IV

Hearing Transcripts



Hearing Summary

OAC Chapter 3745-21, Adoption of mandatory Reasonably Available Control Technology (RACT) requirements for the Cincinnati and Cleveland 2015 ozone nonattainment areas and five year review.

Rule Package: _____

Original filing date: November 29, 2021

Public comment start date: November 29, 2021

Public comment end date: January 3, 2022

Public hearing date: January 3, 2022

List of Rules: 3745-21-01, 3745-21-03, 3745-21-04, 3745-21-06 to 3745-21-29

Were there any participants in this public hearing beyond Ohio EPA staff or JCARR staff?

- Yes No

Were there comments received during the public comment period outside of those presented at this hearing?

- Yes No

This hearing summary has been compiled to meet the requirements of Section 119.03 of the Revised Code.

This hearing summary includes this cover sheet and the following attachments:

1. **Attachment A** - A copy of the public notice for this hearing.
2. **Attachment B** - A copy of the sign-in sheet for this hearing.
3. **Attachment C** - A copy of the script read into the record to begin and end the hearing.
4. **Attachment D** - A copy of the response to comments.

Ohio EPA's response to comments document includes the comments received, who commented, the agency response to comments, and a statement of whether or not the rule was changed due to the comments.

Ohio EPA digitally records all public hearings for rules. The digital recordings are available upon request in a WAVE (.wav) file format. These recordings may be sent out for transcription if necessary.

Public Notice and Public Hearing
Ohio Environmental Protection Agency
Ohio Administrative Code (OAC) Chapter 3745-21, "Carbon Monoxide, Photochemically Reactive
Materials, Hydrocarbons, and Related Materials Standards"
Five-Year Rule Review and Reasonably Available Control Technology (RACT) for the Cincinnati and
Cleveland 2015 Ozone Moderate Nonattainment Areas

Notice is hereby given that the Ohio Environmental Protection Agency, Division of Air Pollution Control (DAPC) has performed a review of the above referenced rules primarily to satisfy the requirements of Section 106.03 and 106.031 of the Ohio Revised Code (five-year review). Upon review, Ohio EPA has determined that certain changes are needed and that all rules in the chapter remain necessary.

Ohio EPA has drafted revisions to OAC chapter 3745-21 to adopt mandatory Reasonably Available Control Technology (RACT) requirements for Cincinnati and Cleveland 2015 ozone nonattainment areas. The Cleveland and Cincinnati nonattainment areas are currently classified as marginal nonattainment for the 2015 ozone standard. The areas are required to meet the ozone standard by August 3, 2021, based on ozone monitoring data collected during the 2018-2020 ozone monitoring seasons, which extend from March 1 to October 31 each year.

The Cleveland and Cincinnati areas have failed to meet the ozone standard during the 2018-2020 ozone monitoring seasons as required and Ohio EPA anticipates that the areas will be reclassified to moderate nonattainment by U.S. EPA in accordance with the Clean Air Act (CAA). Reclassification to moderate nonattainment triggers additional CAA requirements, including VOC RACT requirements. This includes adoption of U.S. EPA Control Technique Guidelines (CTGs) as well as non-CTG VOC RACT for major stationary sources located in the moderate nonattainment areas. Some CTGs and non-CTG VOC RACT were previously adopted under prior ozone standards.

Ohio EPA is also amending these rules to address minor changes needed for clarification and Legislative Service Commission (LSC) formatting protocol.

Please see the rule synopsis, available electronically at the web address below, for a complete summary of the proposed rule amendments.

Pursuant to Section 121.39 of the Ohio Revised Code, DAPC was required to consult with interested parties affected by the rules before the Division formally adopts them. On May 17, 2021 these rules went out for a 30-day review by interested parties. Ohio EPA's responses to comments received is available electronically on Ohio EPA's website at the URL listed below.

Ohio EPA has also prepared a draft RACT State Implementation Plan (SIP) which will be submitted to U.S. EPA along with the above-mentioned rules. Ohio EPA is also seeking public comment on the draft RACT SIP.

Pursuant to Part D of Title I of the CAA, Ohio EPA is required to establish a SIP for the attainment and maintenance of the NAAQS. The above-mentioned rules and RACT SIP are a part of Ohio's SIP for attainment and maintenance of the 2015 ozone NAAQS and the proposed amendments and RACT SIP will be submitted to United States Environmental Protection Agency (U.S. EPA) as a modification of the SIP.

Ohio EPA will hold an in-person and virtual public hearing on the rules on **Monday, January 3, 2022 at**

10:00 AM. The in-person hearing will be at the same time and date and will be located at Ohio EPA, Suite 700, 50 W. Town Street, Columbus, Ohio 43215. During the hearing, the public may submit written comments on the record about the proposed rules. If participating virtually, comments may be submitted electronically and may be submitted verbally if participating in person.

To facilitate the scheduling of oral presentations, persons intending to give testimony in-person at the hearing should notify Cathryn Allen at the Ohio EPA Public Interest Center, cathryn.allen@epa.ohio.gov or (614) 644-2160.

Citizens who want to participate virtually must register in advance for the meeting at: <https://register.gotowebinar.com/register/8634946818248390926>

All interested persons are entitled to attend or be represented at the hearing and give written or oral comments on these rule changes and SIP revisions. All oral comments presented at the hearing, and all written statements submitted at the hearing or by the close of business on January 3, 2022 will be considered by Ohio EPA prior to final action on this rule and SIP revisions. Written statements submitted after January 3, 2022 may be considered as time and circumstances permit but will not be part of the official record of the hearing.

These rules and associated rulemaking documents are available on DAPC's Web page for electronic downloading. The URL is: <https://epa.ohio.gov/dapc/DAPCrules>.

Questions regarding accessing the web site should be directed to Paul Braun at 614-644-3734; other questions or comments about these rules or SIP revisions should be directed to Holly Kaloz at Ohio EPA, (614) 644-3632, holly.kaloz@epa.ohio.gov, or mailed to Holly Kaloz, Ohio EPA, Division Air Pollution Control, Lazarus Government Center, P.O. Box 1049, Columbus, Ohio 43216-1049.

Attendee Report: Public Hearing: VOC RACT Rules (Statewide)

Report Generated:
01/03/2022 11:54 AM
EST

Webinar ID	Actual Start Date/Time	Duration	# Registered	# Attended
918-708-403	01/03/2022 09:28 AM EST	1 hour 2 minutes	12	12

Attendee Details

Attended	Last Name	First Name	Email Address	Organization	Webinar Question 1
Yes	Angelicola	Mary	ma@industrialcompliancesolutions.com	Industrial Compliance Solutions,LLC	Andrew Schall - President of Graphic Media Alliance. GMA is an Association supporting members of the Printing and Graphic Communication Industry. With the ongoing pandemic, supply chain issues, and labor shortages, many of our members find it difficult to sustain. Is there a proposed timeline in place for the proposed RACT changes, and has the current market conditions been considered?
Yes	Boyd	Laura	laura.boyd@cincinnati-oh.gov	MSDGC	
Yes	Brown	Carrie	cbrown@thehcpa.org	HCPA	
Yes	Buzas	Sarah	SBuzas@cecinc.com	CEC, Inc.	
Yes	Fouche	Greg	gfouche@jcarr.state.oh.us	JCARR	
Yes	Georges	Nicholas	ngeorges@thehcpa.org	Household & Commercial Products Association	
Yes	Johnston	Matt	matt.johnston@worthingtonindustries.com		
Yes	Kaufold	Rebecca	RKAUFOLD@SPARTANCHEMICAL.COM	Spartan Chemical Company, Inc.	
Yes	Schall	Andrew	aschall@graphicmedia.org	Graphic Media Alliance	
Yes	Schirra	Christy	cschirra@bricker.com	Bricker & Eckler LLP	
Yes	Sorge	Valerie	sorge.valerie@gmail.com	Molson Coors	
Yes	paterson	whitney	wpaterson@jcarr.state.oh.us		

All attendees did so virtually. There was no in-person attendance at Ohio EPA Main Office, Columbus, Ohio.

SAMPLE RULES SPEECH

Jan. 3, 2021

Hello and welcome to Ohio EPA's virtual public hearing regarding OAC Chapter 3745-21, "Carbon Monoxide, Photochemically Reactive Materials, Hydrocarbons, and Related Materials Standards" Five-Year Rule Review and Reasonably Available Control Technology (RACT) for the Cincinnati and Cleveland 2015 Ozone Moderate Nonattainment Areas.

My name is Jessica Langdon and I'm hosting today's public hearing. Also with me from Ohio EPA is Amanda Payton, Ohio EPA's Rules Coordinator who is in-person. I'd like to note that we are recording this hearing. We will save all comments submitted during the hearing.

Before we get started, I'd like to go over a few items to help you navigate the GoTo platform.

On this slide here you will see an example screenshot of your Attendee interface. You should see something that looks like this on your computer desktop on the right-hand side of your screen. For this public hearing you are listening in using your computer audio. If you are having sound issues or if the slides stop advancing, try refreshing your browser. If that doesn't work, try logging off and logging back in.

Please submit public comments by clicking on the question mark icon and typing them into the Questions pane on your attendee interface. All comments submitted online will be read aloud for the whole audience to hear.

(You can also click on the document icon to view included handouts.)

For those attending in person, you may submit your testimony verbally by moving close to Ms. Payton's broadcast tablet, stating your name, and proceeding with your testimony when we call on you.

PUBLIC HEARING SPEECH

Thank you for taking time to attend this hearing before Ohio EPA. The purpose of the hearing today is to obtain comments from any interested person regarding Ohio EPA's proposed rules.

Ohio EPA is proposing to amend the following rules of the Ohio Administrative Code:

Ohio EPA has drafted revisions to OAC chapter 3745-21 to adopt mandatory Reasonably Available Control Technology (RACT) requirements for Cincinnati and Cleveland 2015 ozone nonattainment areas. The Cleveland and Cincinnati nonattainment areas are currently classified as marginal nonattainment for the 2015 ozone standard. The areas are required to meet the ozone standard by August 3, 2021, based on ozone monitoring data collected during the 2018-2020 ozone monitoring seasons, which extend from March 1 to October 31 each year. The Cleveland and Cincinnati areas have failed to meet the ozone standard during the 2018-2020 ozone monitoring seasons as required and Ohio EPA anticipates that the areas will be reclassified to moderate nonattainment by U.S. EPA in accordance with the Clean Air Act (CAA). Reclassification to moderate nonattainment triggers additional CAA requirements, including VOC RACT requirements. This includes adoption of U.S. EPA Control Technique Guidelines (CTGs) as well as non-CTG VOC RACT for major stationary sources located in the moderate nonattainment areas. Some CTGs and non-CTG VOC RACT were previously adopted under prior ozone standards.

These rules have been filed with the Joint Committee on Agency Rule Review. Copies of the rules are available for public review on our website.

All interested persons are entitled to attend or be represented, and to present written comments concerning the proposed rules. All written comments received as part of the official record will be considered by the director of Ohio EPA.

To be included in the official record, written comments must be received by Ohio EPA by the close of business, **today, Jan 3, 2021**. These comments may be typed into the GoTo platform or spoken in-person today or emailed to holly.kaloz@epa.ohio.gov. All emailed comments submitted for the record receive the same consideration as typed or in-person testimony given today.

Written statements submitted after today may be considered as time and circumstances permit but will not be part of the official record of the hearing.

This hearing affords citizens an opportunity to provide input. Therefore, we will not be able to answer questions today.

YOU MAY NOW SUBMIT COMMENTS. I will read aloud any comments we receive in the GoTo platform. If you are attending in-person and would like to submit testimony, please raise your hand, and wait to be called on. I will keep the GoTo platform open until XXXXX to provide time for participants to type in comments.

CLOSING

We will close the hearing. After the hearing closes, we will accept written comments through 5:00 p.m. Today, Jan. 3, 2021. You can send those comments to the email address on the screen.

Thank you for your comments, cooperation and participation in Ohio EPA's decision-making process. The time is now _____ and this hearing is concluded.



Division of Air Pollution Control Response to Comments

Rule: OAC Chapter 3745-21 Carbon Monoxide, Photochemically Reactive Materials, Hydrocarbons, and related Materials Standards

Agency Contact for this Package

Division Contact: Holly Kaloz, DAPC, 614-644-3632, holly.kaloz@epa.ohio.gov

Ohio EPA held a public hearing on January 3, 2022, regarding the adoption of mandatory Reasonably Available Control Technology (RACT) requirements for the Cincinnati and Cleveland 2015 ozone nonattainment areas and the five year review of OAC Chapter 3745-21. This document summarizes the comments and questions received at the public hearing and during the associated 30 day comment period, which ended on January 3, 2022.

Ohio EPA reviewed and considered all comments received during the public comment period. By law, Ohio EPA has authority to consider specific issues related to protection of the environment and public health.

In an effort to help you review this document, the questions are grouped by topic and organized in a consistent format. The name of the commenter follows the comment in parentheses.

General Comments

Comment 1: GMA is an Association supporting members of the Printing and Graphic Communication Industry. With the ongoing pandemic, supply chain issues, and labor shortages, many of our members find it difficult to sustain. Is there a proposed timeline in place for the proposed RACT changes, and has the current market conditions been considered?
(Andrew Schall, President of Graphic Media Alliance)

Response 1: The deadline to comply with control technique guidelines (CTGs) for facilities located in the Cincinnati 2015 ozone nonattainment area (Butler, Clermont, Hamilton and Warren counties) is March 1, 2023. For facilities subject to non-CTG RACT, the deadline to submit a new or updated RACT study is within one year after the effective date of the rule.

Ohio EPA understands the challenges to the regulated community posed by the pandemic, supply chain issues and labor shortages. The compliance dates coordinate with the last year for attainment under the

moderate nonattainment timeline. Continued reductions in the Cincinnati area will help to ensure additional bumps don't occur in the future with additional federally mandated requirements.

With that in mind, Ohio EPA acknowledges that there may be rare circumstances that pose challenges for specific facilities, and in those instances, we typically work with the facilities on a case-by-case basis in collaboration with U.S. EPA Region 5. In the unusual circumstance a facility cannot comply with a requirement or meet an established deadline, Ohio EPA urges the facility to reach out early in the process so we can review the specific circumstances and work with the facility in collaboration with U.S. EPA to find alternatives, where alternatives are justified.

End of Response to Comments

Article V

Response to Comments



Division of Air Pollution Control Response to Comments

Rule: OAC Chapter 3745-21, "Carbon Monoxide, Photochemically Reactive Materials, Hydrocarbons, and Related Materials Standards" – 5 Year Review and Reasonably Available Control Technology (RACT) for the Cincinnati and Cleveland 2015 Ozone Moderate Nonattainment Areas

Agency Contact for this Package

Holly Kaloz, Division of Air Pollution Control, (614) 644-3632, holly.kaloz@epa.ohio.gov

Ohio EPA held an interested party comment period on May 17, 2021 regarding draft amended rules in Ohio Administrative Code (OAC) Chapter 3745-21, "Carbon Monoxide, Photochemically Reactive Materials, Hydrocarbons, and Related Materials Standards". This document summarizes the comments and questions received during the comment period, which ended on June 18, 2021.

Ohio EPA reviewed and considered all comments received during the public comment period. By law, Ohio EPA has authority to consider specific issues related to protection of the environment and public health.

In an effort to help you review this document, the questions are grouped by topic and organized in a consistent format. The name of the commenter follows the comment in parentheses.

General Comments

Comment 1: "Lastly, and more generally, many of the proposed rule changes impose compliance deadlines or other time limits upon industry. How will Ohio EPA consider requests to extend these deadlines as needed, as facilities work to evaluate the best means of compliance with the rules? What factors did Ohio EPA consider in evaluating the manner in which to expand these requirements for the Cincinnati and/or Cleveland nonattainment areas? OMA urges Ohio EPA to carefully consider whether industry will be able to comply with the future terms and conditions of environmental permits issued to industry that incorporate these proposed rule changes, and the cost to industry of doing so. Our organization respectfully request to be included in meetings or future discussions pertaining to amendments to these rules and looks forward to reviewing any additional proposed

changes to these rules.” **(Rob Brundrett, Ohio Manufacturer’s Association)**

Response 1: Reclassification of the Cincinnati and Cleveland areas to moderate nonattainment triggers additional Clean Air Act (CAA) requirements, including VOC RACT requirements. Ohio is required under the CAA to meet these requirements, including requiring compliance with RACT by specific deadlines.

Ohio EPA acknowledges that there may be rare circumstances that pose challenges for specific facilities, and in those instances, we typically work with the facilities on a case by case basis in collaboration with U.S. EPA Region 5. In the unusual circumstance a facility cannot comply with a requirement or meet an established deadline, Ohio EPA urges the facility to reach out early in the process so we can review the specific circumstances and work with the facility in collaboration with U.S. EPA to find alternatives, where alternatives are justified.

Ohio EPA began this rulemaking process as early as possible in order to provide advance notice of the upcoming requirements and opportunity for input. We have actively engaged with stakeholders (including OMA) throughout this process and plan to do more targeted outreach with newly subject facilities to ensure they have plenty of time to understand and comply with the requirements. Future meetings and discussions will be open to all stakeholders and OMA will be continued to be notified of opportunities to provide input.

OAC 3745-21-07 Control of Emissions of Organic Materials from Stationary Sources

Comment 2: “In these proposed rule changes, Ohio EPA has added “TRC Buyer Co. dba “The Ruscoe Company” Plant II”, Facility ID 1677010204, to the table in 21-07(M)(1). I believe that this is a mistake, and that Ruscoe (my client) should not be added here.” **(Eric Tabor, Tabor Air Compliance)**

“TRC Buyer Co. dba “The Ruscoe Company” Plant II was added to the Table un (M)(1) in OAC rule 3745-21-07. While writing the renewal permit, I determined that OAC rule 3745-21-07(M)(1) was not applicable to this facility based on the white papers and the Ashland case. The facility had request to rescind the request to have the facility added to OAC rule 3745-21-07(M)(1). Please remove this facility from the Table under (M)(1) of OAC rule 3745-21-07.” **(Laura Miracle, Akron Air Quality Management District)**

Response 2: Ohio EPA has removed "TRC Buyer Co. dba "The Ruscoe Company" from the rule at this time pending a review of the processes at the company. The review is intended to determine if the processes should be regulated under OAC 3745-21-07(M)(1). Should Ohio EPA determine that the facility should be regulated under this paragraph, the addition of the company to this paragraph will be addressed in a future rulemaking.

OAC 3745-21-11 Reasonably available control technology studies for non-CTG sources in ozone nonattainment areas

Comment 3: "Additionally, the draft rules include a new OAC 3745-21-11 RACT study for non-CTG sources in ozone nonattainment areas. The applicability for this rule seems unnecessarily limiting. It requires assessing the actual or potential emissions of VOCs "from sources which are not controlled by Ohio's CTG regulations in this chapter." The term "CTG" is defined to include most, but not all, VOC rules contained in OAC Chapter 3745-21. The term should be broadened to include any VOC rule contained in OAC Chapter 3745-21. In addition, the phrase "controlled by" could be interpreted as limiting the term to only those regulations that require actual controls. The phrase "subject to" is more encompassing. As such, OMA requests that Ohio EPA revise this term to state "from sources which are not subject to a rule in this chapter." **(Rob Brundrett, Ohio Manufacturer's Association)**

Response 3: Ohio EPA agrees that some other rules in 3745-21 beyond the CTGs should be considered in determining the applicability for a RACT study, such as sources controlled by categorical non-CTG RACT. However, Ohio does not believe it is appropriate to broaden the definition of CTG to include non-CTG rules as was recommended. Rather, we have revised OAC 3745-21-11(A)(2) as follows: "The facility emits or has the potential to emit as defined in rule 3745-21-01 of the Administrative Code, one hundred tons or more of VOC emissions as of the effective date of this rule from sources which are not controlled by Ohio's CTG regulations in this chapter or by categorical non-CTG RACT contained in rules 3745-21-12, 3745-21-14, 3745-21-16, 3745-21-21 and 3745-21-25 of the Administrative Code."

Additionally, Ohio does not believe it would be appropriate to change "controlled by" to "subject to" as a source could be subject to a provision (such as keeping certain records) which does not actually control or limit the emissions of that source. For clarity, we have added the following comment to the rule: [Comment: For the

purposes of this rule, "controlled by" is not limited to physical pollution controls but may include other types of controls such as VOC content limitations, operational limits or work practices.]

Comment 4:

Furthermore, the new RACT study rule at OAC 3745-21-11 also should include a provision that excludes certain sources from the scope of the detailed engineering study. Three such exclusions are apparent:

- a. First, the rule should exclude certain low-emitting VOC sources from the scope of the engineering study. The engineering study will become unwieldy if a facility is required to assess even the most trivial VOC sources. It is unlikely that meaningful reductions will be identified for such low-emitting VOC sources. OMA suggests that any source emitting 10 tons per year or less of VOCs should be excluded from the scope of the study.
- b. Second, the rule should exclude from the scope of the engineering study sources that are subject to NESHAP standards that are intended to control at least in part VOC emissions. By definition, Maximum Achievable Control Technology (MACT) is at least as stringent as RACT. Therefore, a source subject to MACT should not have to further assess the emissions to establish RACT. One such example is 40 CFR Part 61, Subpart L (National Emission Standard for Benzene Emissions from Coke By-Product Recovery Plants). Through the control of benzene, this regulation necessarily also controls other VOCs present in the emissions from the source. It is therefore unnecessary to assess such sources for RACT.

This is the case even if the NESHAP does not expressly include VOC limits, but nonetheless results in control of VOCs. Examples include 40 CFR Part 63, Subparts L (National Emission Standards for Coke Oven Batteries) and CCCCC (National Emission Standards for Coke Ovens: Pushing, Quenching and Battery Stacks). In these regulations, the limits are mostly particulate matter limits, but those particulate matter limits are used as surrogates for control of coke oven emissions. Coke oven emissions include many organic compounds, including VOCs such as benzene, toluene and xylene.

Consequently, OMA requests that Ohio EPA exclude from the scope of the detailed engineering study any sources subject to a NESHAP standard that regulates VOC emissions either directly or indirectly.

- c. Third and finally, the rule should exclude from the scope of the engineering study VOCs from gaseous fuel combustion. No RACT could apply to the emission of VOCs from the combustion of gaseous fuels; thus, resources would not be well spent on such studies. **(Rob Brundrett, Ohio Manufacturer's Association)**

Response 4: Ohio EPA does not believe the requested exclusions from the scope of a RACT study are appropriate, as described in further detail below:

- a. An exclusion for low-emitting sources (more accurately, low emitting processes or operations) is not consistent with U.S. EPA's non-CTG RACT guidance. RACT guidance requires states to include sources (i.e., processes or operations) that would have been covered by a CTG but fall below the applicability threshold when calculating potential emissions for non-CTG RACT applicability. These sources could very well fall into the definition of "low emitting" as suggested by the commenter. The non-CTG study may determine that no control is RACT for these sources, but they must be included in the calculation of potential emissions and control options must be evaluated.
- b. Ohio EPA cannot provide a blanket exemption for sources subject to NESHAP requirements. Many sources are subject to multiple limits established for multiple purposes. For example, coke ovens are generally subject both to SIP limits, for purposes of meeting requirements relating to attainment of air quality standards, and to MACT limits, for purposes of meeting requirements relating to control of hazardous air pollutants. The limits and test methods that are appropriate for one purpose are not necessarily appropriate for another purpose. The regulation of a source by other provisions that may provide some VOC control, directly or indirectly, in particular regulations established for a different purpose (for regulating hazardous air pollutants and not for regulating criteria pollutants) does not justify a blanket exemption from the mandatory SIP requirement.

However, the applicable NESHAP and other federally enforceable requirements can be considered as part of the RACT process in two ways.

First, federally enforceable limits can be considered as part of the calculation of the potential to emit. In accordance with OAC rule 3745-21-01(B)(15): "Potential to emit" means the maximum capacity of a facility or stationary source to emit an organic

compound or VOC under its physical and operational design. Any physical or operational limitation on the capacity of the facility or stationary source to emit an organic compound or VOC, including air pollution control equipment and restrictions on hours of operation or on the type or amount of material combusted, stored or processed, shall be treated as part of its design if the limitation or the effect it would have on emissions is federally enforceable. This PTE determination should be discussed in detail with Ohio EPA to ensure the specific provision meets the criteria to be considered in the determination for PTE.

Second, it may be possible to demonstrate through the RACT study that the NESHAP constitutes RACT for a specific source. However, this would be a case-by-case determination that considers the specific emissions limitation, compliance method, and monitoring, recordkeeping and reporting requirements. It has been EPA's position that controls required by a NESHAP are not necessarily equivalent to RACT. RACT guidance allows states/sources to include controls from NESHAPs in the calculation of potential emissions. However, a blanket exemption from consideration of RACT requirements because a source is subject to a NESHAP is not something EPA would approve.

- c. An exclusion for VOCs from gaseous fuel combustion is not provided for in U.S. EPA's RACT guidance and we are not aware of any other states that have such an exclusion. We do not believe a blanket exclusion would be appropriate, but it may be possible to demonstrate through the RACT study that no control is RACT for these sources.

Ohio EPA also wishes to clarify that RACT applicability and analysis only applies to air contaminant sources, as defined in OAC 3745-15-05(A)(3), that are subject to Ohio EPA air regulations. Under OAC 3745-15-05(B), air contaminant sources that have a de minimis level of emissions are exempt from Ohio's air regulations, and therefore RACT. Ohio EPA will work with facilities required to perform a non-CTG RACT analysis on a one-on-one basis to ensure the appropriate sources at the facility are included in the full non-CTG RACT analysis.

OAC 3745-21-26 Surface coating of miscellaneous metal and plastic parts

Comment 5: "First, the Cleveland-Cliffs Steel Corporation mill in Butler County (formerly AK Steel Corporation) is subject to site-specific VOC content limits for rolling oil, rust preventative oil, anti-galling material

and prelube oil pursuant to OAC 3745-21-09(OO). The draft rules include an expansion of OAC 3745-21-26 (surface coating of miscellaneous metal and plastic parts) to now include Butler County. The OMA and Cleveland-Cliffs Steel do not believe that any of the oils or material subject to OAC 3745-21-09(OO) fall within the applicability of OAC 3745-21-26. Nonetheless, in order to avoid any ambiguity in applicability, OMA requests that OAC 3745-20-09(OO) be added to the list of exemptions in OAC 3745-21-26(A)(3), along with the list of other exempt 21-09 standards." **(Rob Brundrett, Ohio Manufacturer's Association)**

Response 5:

Ohio EPA cannot provide a blanket exemption for CTG requirements triggered by moderate nonattainment with the 2015 ozone standard based on existing site-specific RACT established under a previous standard. If Cleveland-Cliffs determines these sources fall within the applicability of OAC 3745-21-26, the facility will need to comply with both the existing site-specific RACT in OAC 3745-21-09(OO) as well as OAC 3745-21-26. If clarification on whether these sources are subject to a rule is needed, Cleveland Cliffs can request an applicability determination from Ohio EPA.

In addition, Cleveland Cliffs will need to submit an updated RACT study for the site-specific RACT in OAC 3745-21-09(OO) in accordance with OAC rule 3745-21-11(E) in order to affirm that the existing provisions continue to represent RACT for the 2015 ozone standard or to establish updated RACT provisions.

End of Response to Comments



Division of Air Pollution Control Response to Comments

Rule: OAC Chapter 3745-21 Carbon Monoxide, Photochemically Reactive Materials, Hydrocarbons, and Related Materials Standards

Agency Contact for this Package

Division Contact: Holly Kaloz, DAPC, 614-644-3632, holly.kaloz@epa.ohio.gov

Ohio EPA held a public hearing on January 3, 2022 regarding the adoption of mandatory Reasonably Available Control Technology (RACT) requirements for the Cincinnati and Cleveland 2015 ozone nonattainment areas and the five year review of OAC Chapter 3745-21. This document summarizes the comments and questions received at the public hearing and during the associated 30 day comment period, which ended on January 3, 2022.

Ohio EPA reviewed and considered all comments received during the public comment period. By law, Ohio EPA has authority to consider specific issues related to protection of the environment and public health.

In an effort to help you review this document, the questions are grouped by topic and organized in a consistent format. The name of the commenter follows the comment in parentheses.

General Comments

Comment 1: GMA is an Association supporting members of the Printing and Graphic Communication Industry. With the ongoing pandemic, supply chain issues, and labor shortages, many of our members find it difficult to sustain. Is there a proposed timeline in place for the proposed RACT changes, and has the current market conditions been considered? **(Andrew Schall, President of Graphic Media Alliance)**

Response 1: The deadline to comply with control technique guidelines (CTGs) for facilities located in the Cincinnati 2015 ozone nonattainment area (Butler, Clermont, Hamilton and Warren counties) is March 1, 2023. For facilities subject to non-CTG RACT, the deadline to submit a new or updated RACT study is within one year after the effective date of the rule.

Ohio EPA understands the challenges to the regulated community posed by the pandemic, supply chain issues and labor shortages.

The compliance dates coordinate with the last year for attainment under the moderate nonattainment timeline. Continued reductions in the Cincinnati area will help to ensure additional bump-ups don't occur in the future with additional federally mandated requirements.

With that in mind, Ohio EPA acknowledges that there may be rare circumstances that pose challenges for specific facilities, and in those instances, we typically work with the facilities on a case-by-case basis in collaboration with U.S. EPA Region 5. In the unusual circumstance a facility cannot comply with a requirement or meet an established deadline, Ohio EPA urges the facility to reach out early in the process so we can review the specific circumstances and work with the facility in collaboration with U.S. EPA to find alternatives, where alternatives are justified.

End of Response to Comments