

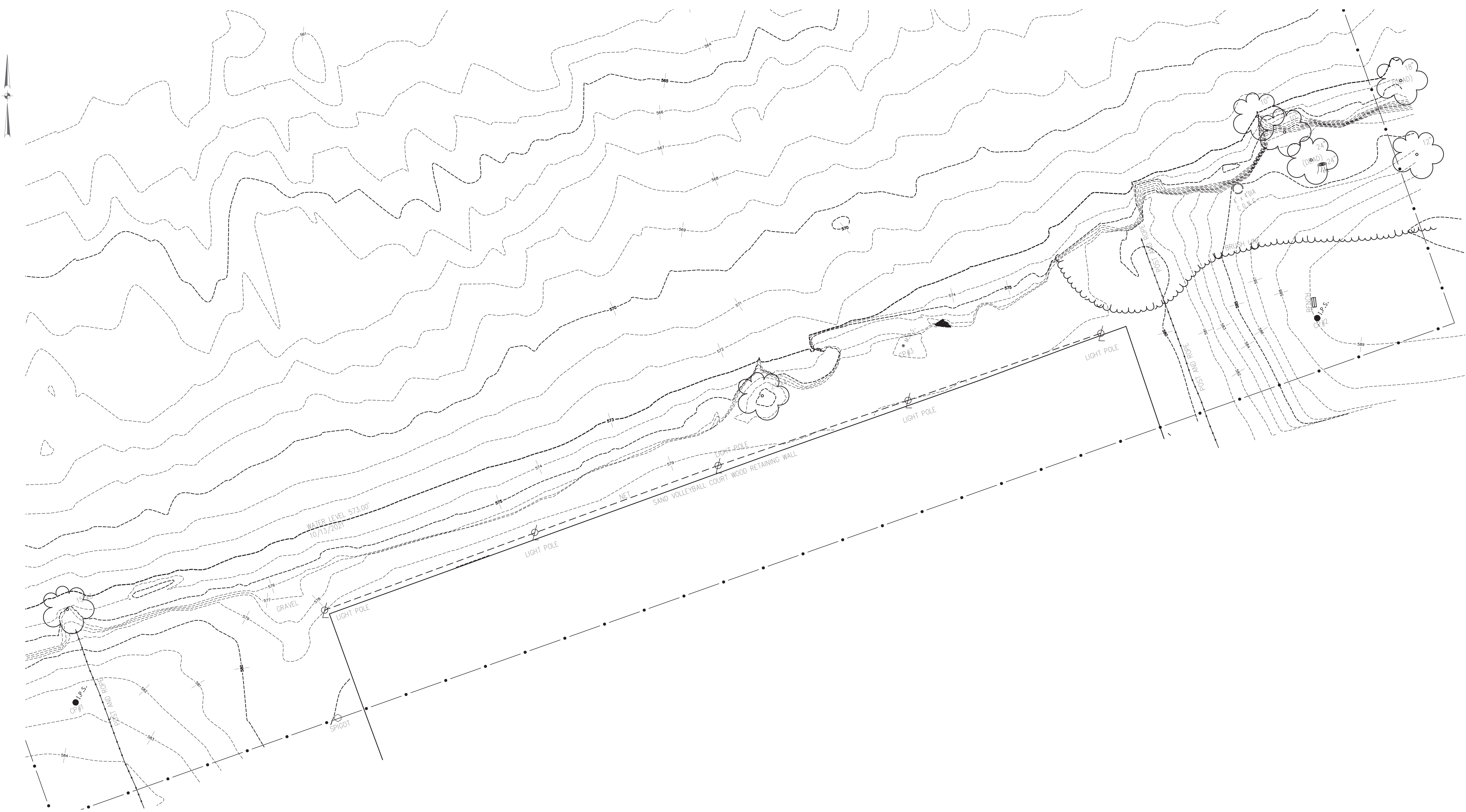



\\ksa-naef\project\20083\wendy\_park\_nature\_based\_shoreline\2021\current drawings\sheet\20083-2-Existing\_Site\_Plan\_Wendy\_Park.dwg, Plotter: Dec 19, 2022 - 9:58am



**NOTES**

1. VERTICAL DATUM IS IGLD 1985.
2. HORIZONTAL DATUM IS THE OHIO STATE PLANE COORDINATE SYSTEM, NORTH ZONE, NAD83 (2011), U.S. SURVEY FEET.
3. TOPOGRAPHIC SURVEY PERFORMED BY CLEVELAND METROPARKS ON OCTOBER 13, 2021. WATER LEVEL AT TIME OF SURVEY WAS 573.0 FEET IGLD 1985.

CONTROL POINT TABLE				
POINT	DESCRIPTION	EL	N	E
CP#1	IPINS -1/2 METROPARKS TRAV CAP	582.81'	668749.4630'	2183524.174'
CP#2	IPINS -1/2 METROPARKS TRAV CAP	589.20'	668904.6650'	2184025.369'
CP#3	MAGS -HUB	578.48'	668893.5110'	2183858.285'

\*ALL POINT ELEVATIONS IN IGLD85 DATUM CONVERTED FROM NAVD88 BY A FACTOR OF -0.25'

**EXISTING SITE PLAN**



**LEGEND**

- △ KS CONTROL POINT
- ⊙ MONUMENT BRASS DISK
- ☼ DECIDUOUS TREE

**LINETYPE LEGEND**

- PROPERTY LINE
- RIGHT OF WAY

**SURVEYOR'S NOTES**

1. THE BASIS OF BEARINGS FOR THIS SURVEY IS OHIO STATE PLANE, NORTH ZONE NAD83(2011) GRID NORTH.
  2. VERTICAL DATUM IS IGLD 1985.
  3. PERTINENT RECORDS USED ARE AS SHOWN HEREON.
  4. THIS MAP AND THE SURVEY ON WHICH IT IS BASED HAVE BEEN PREPARED WITHOUT THE BENEFIT OF A TITLE REPORT AND ARE NOT INTENDED TO REFLECT ALL EASEMENTS, ENCUMBRANCES, OR OTHER CIRCUMSTANCES AFFECTING THE TITLE TO THE PROPERTY SHOWN HEREON.
  5. PROPERTY LINES AND RIGHT OF WAY LINES ARE SHOWN FROM LUCAS AND OTTAWA COUNTY GIS INFORMATION AND ARE NOT INTENDED TO REPRESENT A COMPLETE BOUNDARY SURVEY.
- DATE OF SURVEY: SEPTEMBER 2021

**KS Associates, Inc.**  
 260 Burns Road, Suite 100  
 Elyria, OH 44035  
 P 440 365 4730  
 F 440 365 4790  
 www.ksassociates.com

**Cleveland Metroparks**  
 PROJECT NUMBER : 20083  
 www.clevelandmetroparks.com

**EXISTING SITE PLAN**  
**NATURE-BASED SHORELINE**  
**PROTECTION AT WENDY PARK**  
 2800 WHISKEY ISLAND DRIVE, OHIO 44102

NO.	DESCRIPTION	DATE	BY
		DATE	DATE

SCALE CHECK: \_\_\_\_\_ THIS MARK SHOULD MEASURE EXACTLY 1" WHEN PLOTTED

DATE: 9/21/2022  
 SHEET NO.



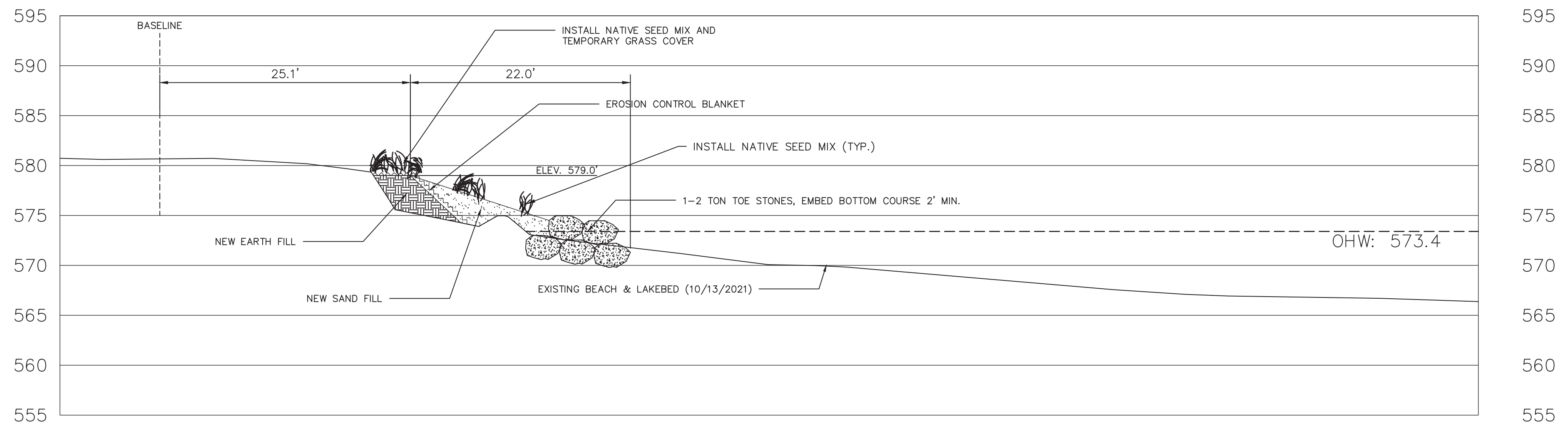

	TOE STONE
	ARMOR STONE
	NEW EARTH FILL
	TOPSOIL WITH SOD
	NEW SAND FILL

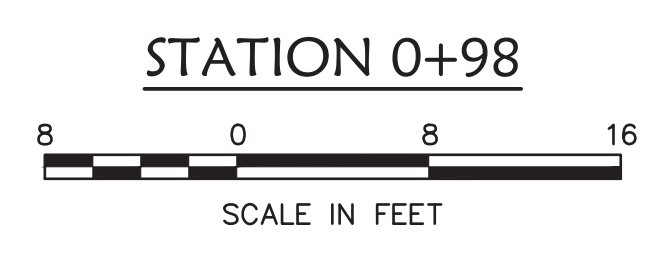
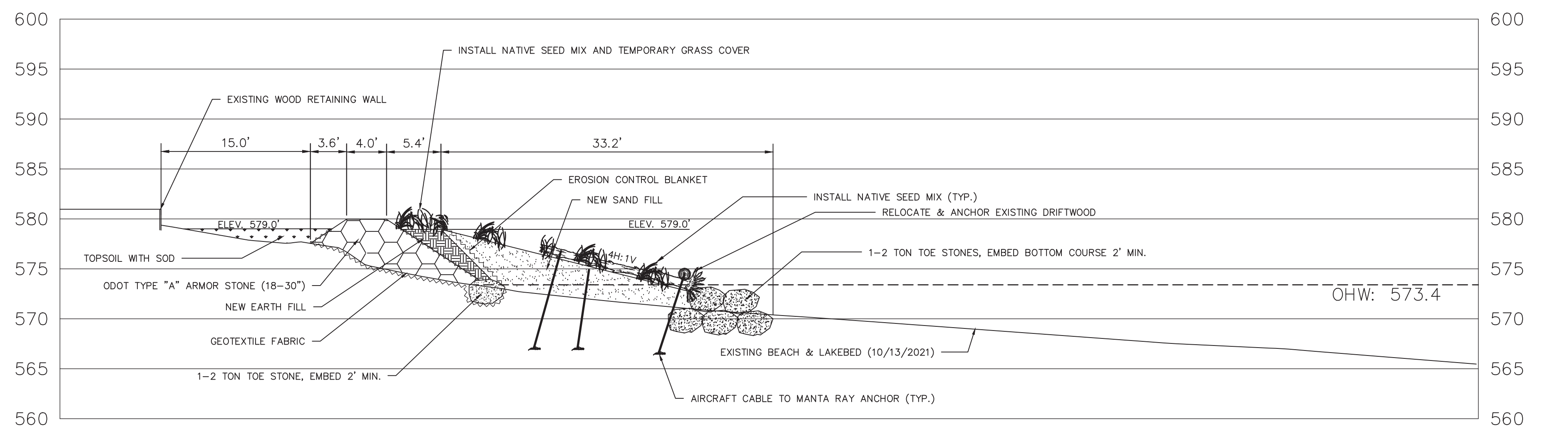
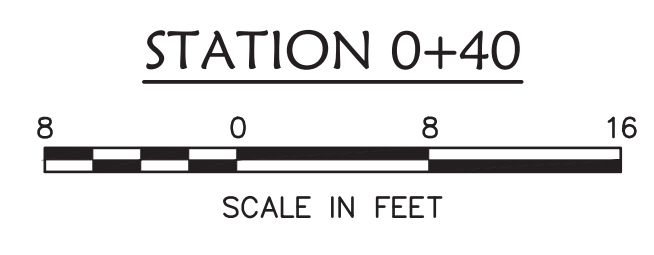

- NOTES:**
- ALL SAND AND GRAVEL EXCAVATED IN THE FOOTPRINTS OF THE PROPOSED STONE STRUCTURES SHALL BE SIDECAST LAKEWARD.

NO.	DESCRIPTION	DATE	BY

SCALE CHECK:  THIS MARK SHOULD MEASURE EXACTLY 1" WHEN PLOTTED

R:\2000\20083-Wendy\_Park\_Nature\_Based\_Shoreline\CIVIL\_3D\_2021\CURRENT DRAWINGS\SHEETS\0083-4\Sections\_Wendy\_Park.dwg, Plotted: Dec 19, 2022 - 11:58am

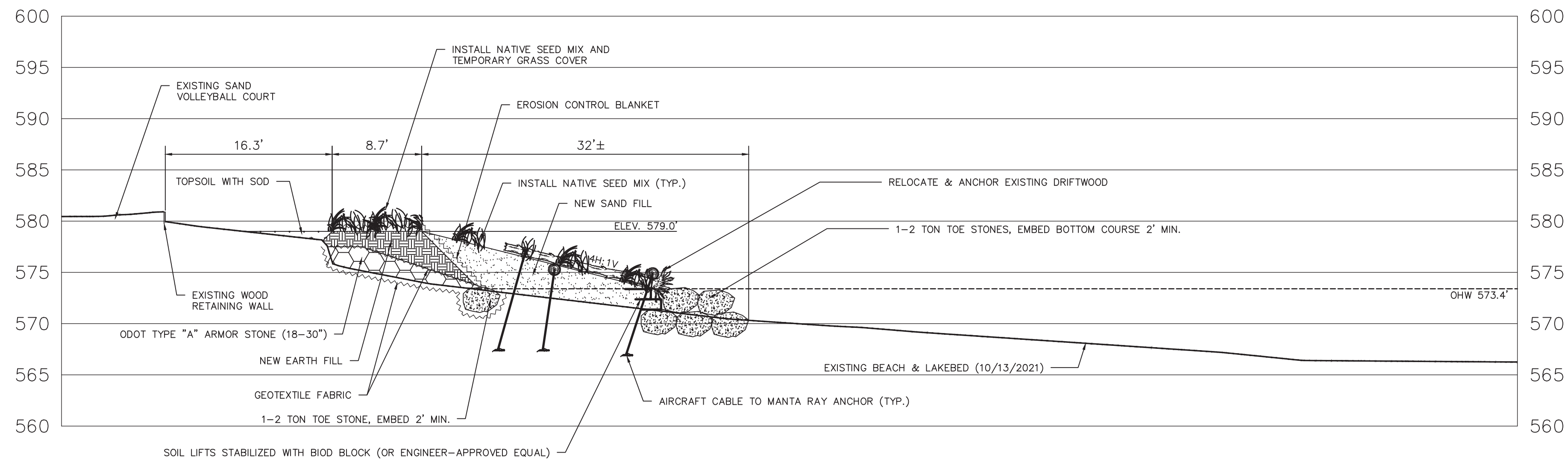

	TOE STONE
	ARMOR STONE
	NEW EARTH FILL
	TOPSOIL WITH SOD
	NEW SAND FILL

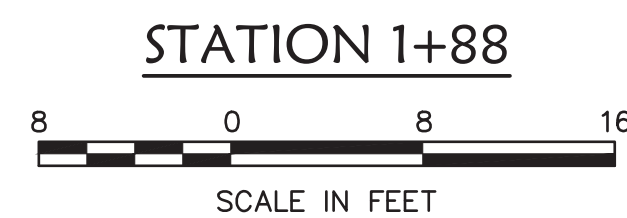
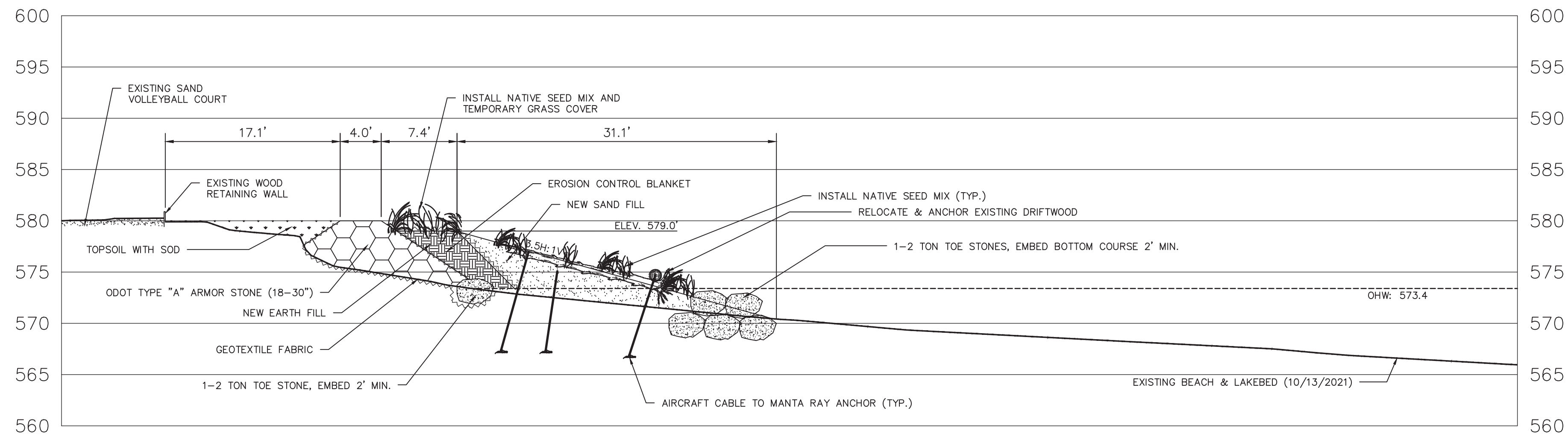
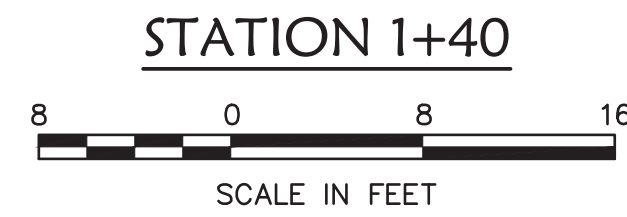

- NOTES:**
- ALL SAND AND GRAVEL EXCAVATED IN THE FOOTPRINTS OF THE PROPOSED STONE STRUCTURES SHALL BE SIDECAST LAKEWARD.

NO.	DESCRIPTION	DATE	BY

SCALE CHECK:  THIS MARK SHOULD MEASURE EXACTLY 1" WHEN PLOTTED

R:\2000\20083-Wendy\_Park\_Nature\_Based\_Shoreline\CIVIL\_3D\_2021\CURRENT DRAWINGS\SHEETS\0083-4\Sections\_Wendy\_Park.dwg, Plotted: Dec 19, 2022 - 12:03pm

R:\2000\2083-Wendy\_Park\_Nature\_Based\_Shoreline\_Civil\_3D\_2021\CURRENT DRAWINGS\SHEETS\0083-4\Sections\_Wendy\_Park.dwg, Plotted: Dec 19, 2022 - 12:10pm

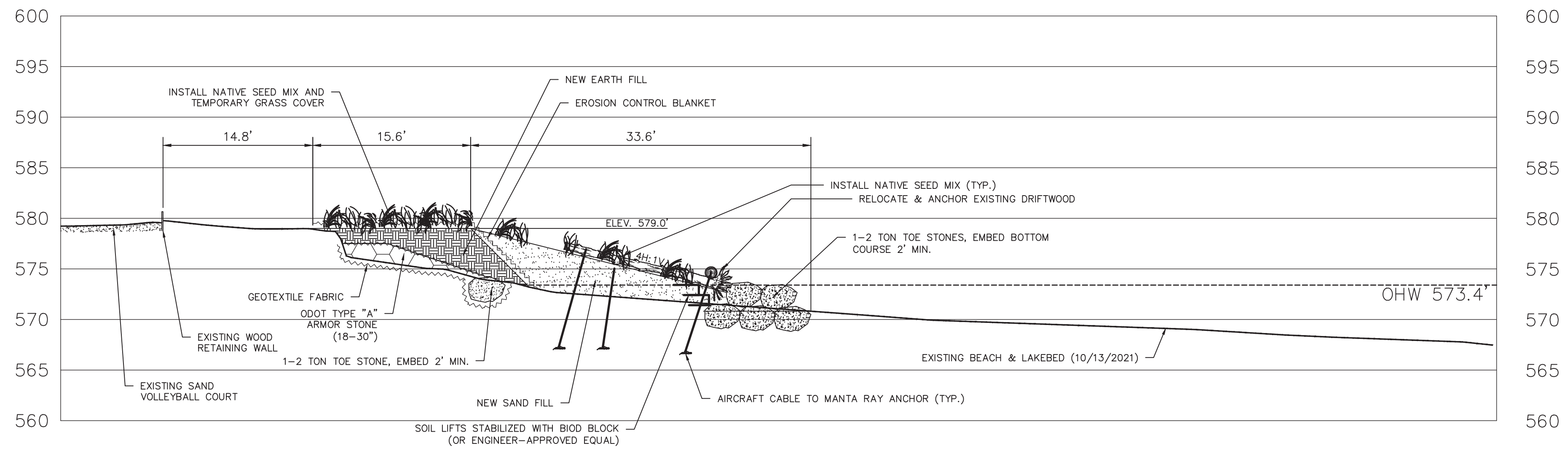

STATION 2+66



	TOE STONE
	ARMOR STONE
	NEW EARTH FILL
	TOPSOIL WITH SOD
	NEW SAND FILL

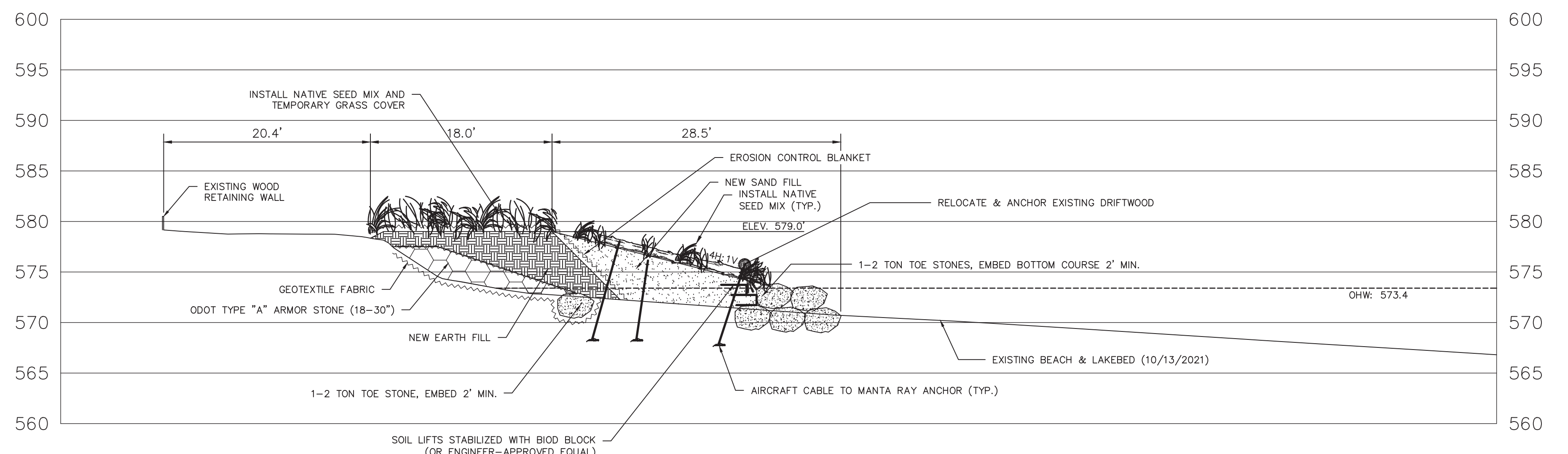

STATION 3+07



- NOTES:
1. ALL SAND AND GRAVEL EXCAVATED IN THE FOOTPRINTS OF THE PROPOSED STONE STRUCTURES SHALL BE SIDECAST LAKEWARD.

**KS** Associates, Inc.  
 260 Burns Road, Suite 100  
 Elyria, OH 44035  
 P 440 365 4730  
 F 440 365 4790  
 www.ksassociates.com

**Cleveland Metroparks**  
 PROJECT NUMBER : 20083  
 www.clevelandmetroparks.com

SECTIONS  
 NATURE-BASED SHORELINE  
 PROTECTION AT WENDY PARK  
 2800 WHISKEY ISLAND DRIVE, OHIO 44102

NO.	DESCRIPTION	DATE	BY

SCALE CHECK:  THIS MARK SHOULD MEASURE EXACTLY 1" WHEN PLOTTED

DATE: 11/10/2022  
 SHEET NO.



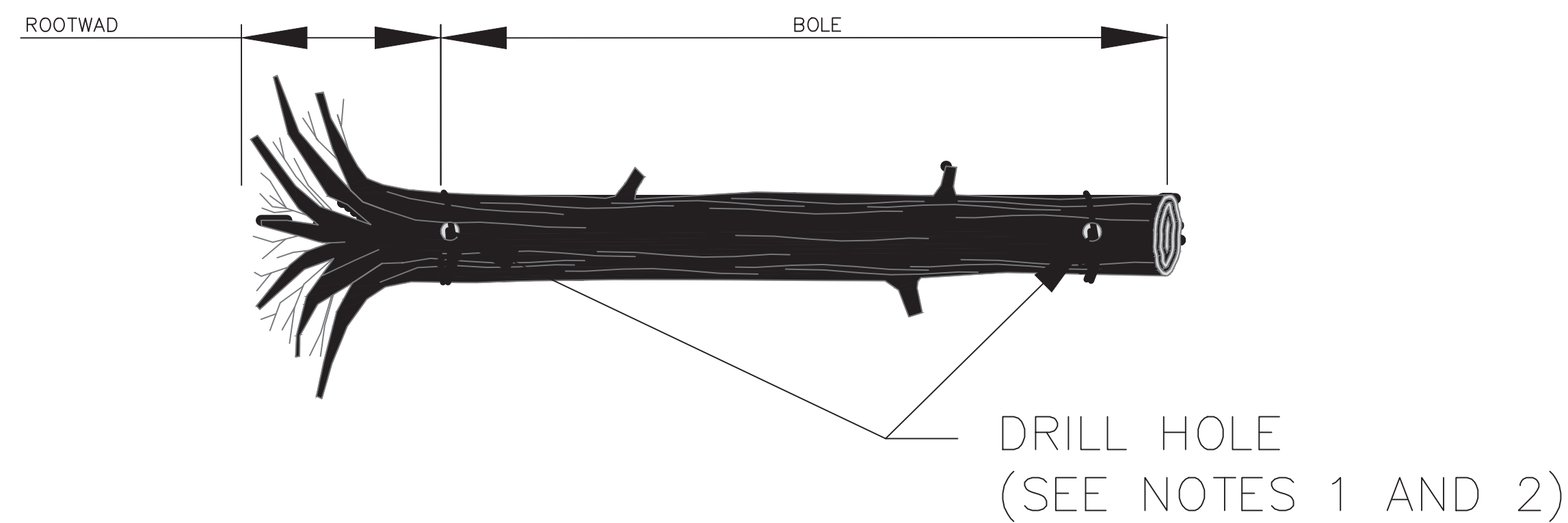

PLAN VIEW  
(NO SCALE)

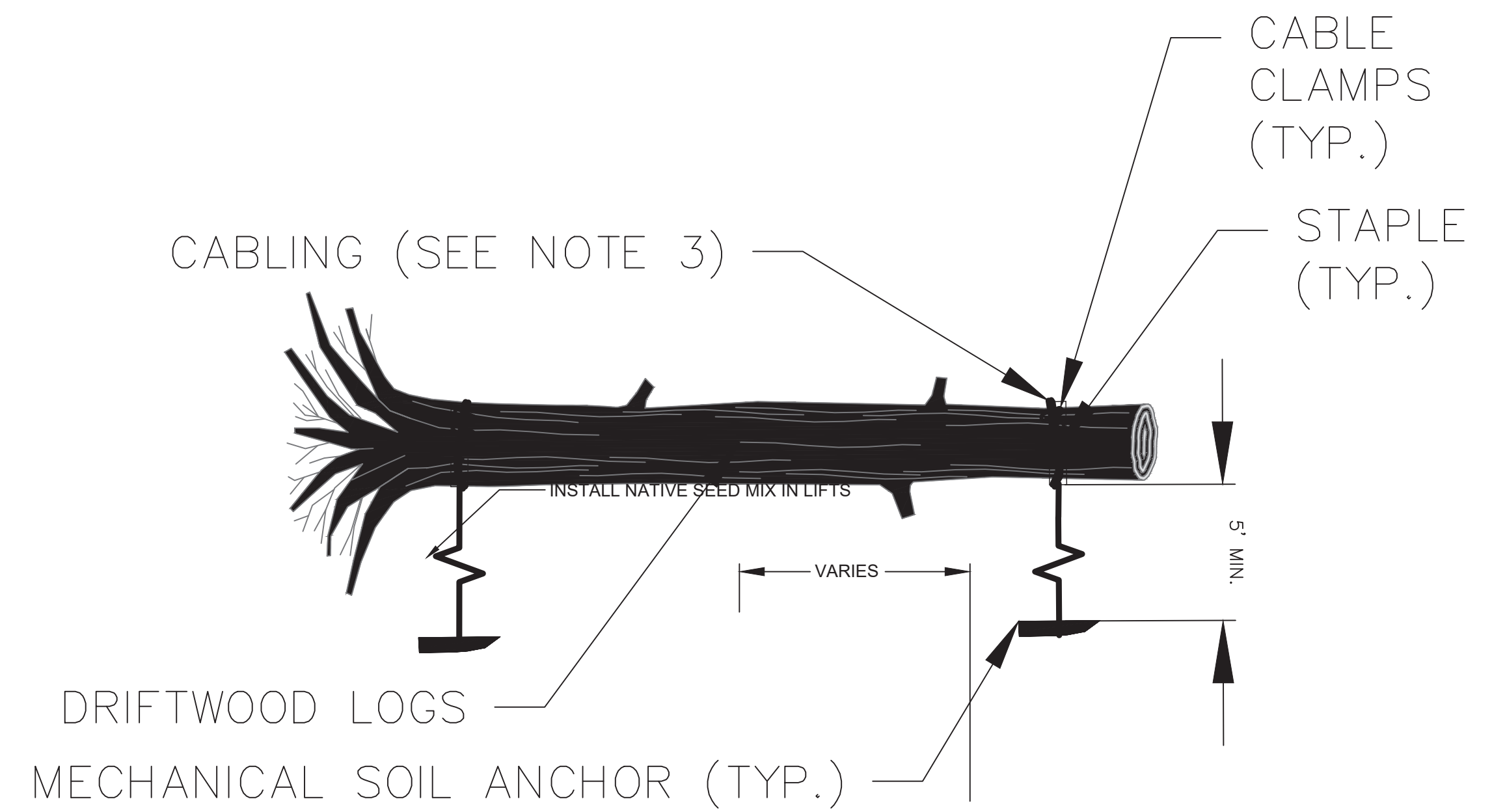

ASSEMBLED PROFILE VIEW  
(NO SCALE)

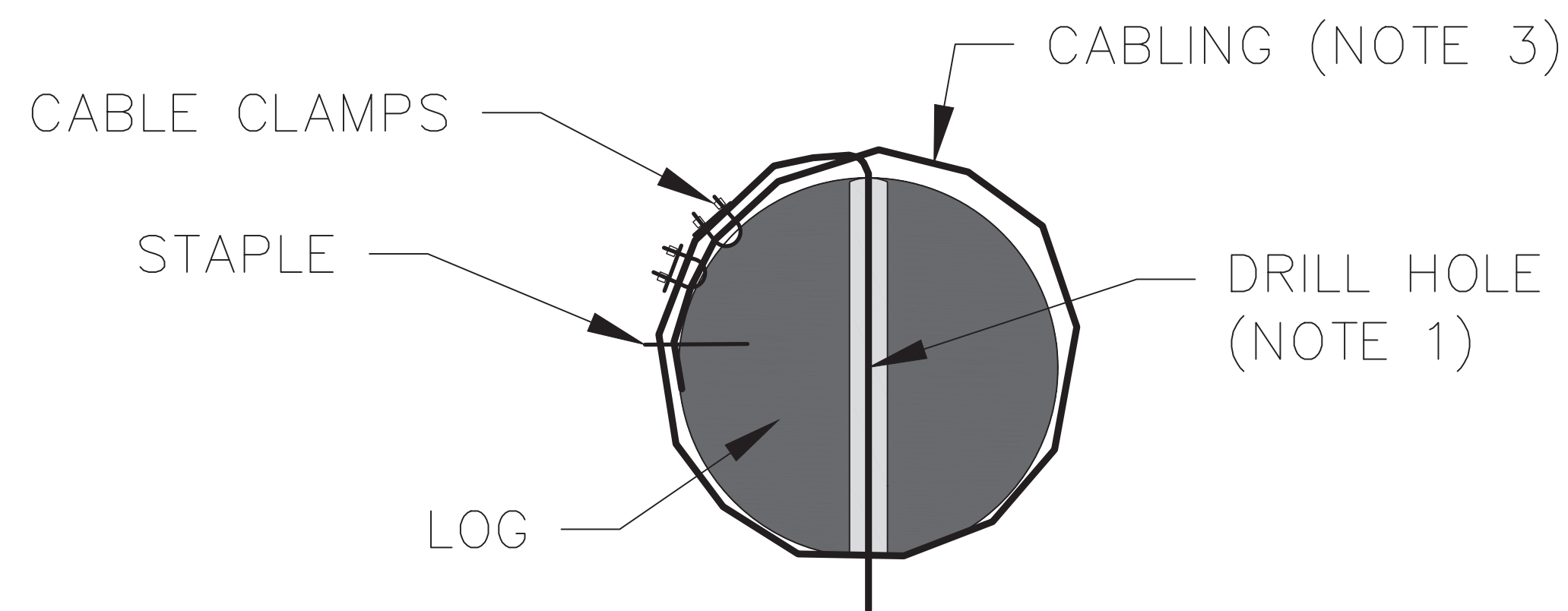

ASSEMBLED SECTION VIEW  
(NO SCALE)

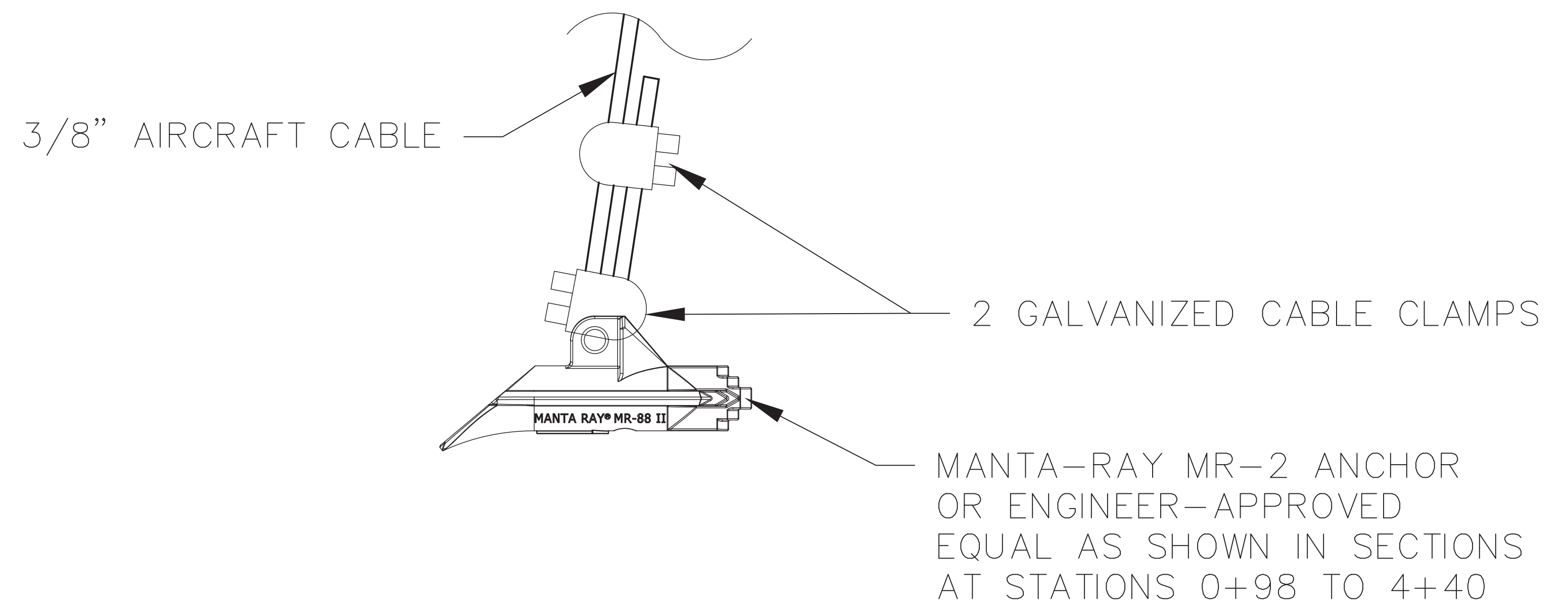

ANCHORING DETAIL FOR  
DRIFTWOOD LOGS  
(NO SCALE)

**NOTES**

- LOGS MAY BE PREDRILLED. DRILL LOGS IN THE CENTER OF THE BOLE. HOLE DIAMETER NOT TO EXCEED 1.50 TIMES THE CABLE DIAMETER.
- THERE WILL BE 2 HOLES FOR DRIFTWOOD LOGS > 16 FEET IN LENGTH AND 1 HOLE FOR DRIFTWOOD LOGS < 16 FEET IN LENGTH. FOR DRIFTWOOD LOGS < 16 FEET IN LENGTH, THE HOLE SHALL BE DRILLED AT THE MIDPOINT OF THE BOLE.
- ANCHOR LOAD LOCKED DEPTH SHALL BE NO LESS THAN SHOWN ON THE PLANS. FINAL INSTALLATION TO BE APPROVED BY THE ENGINEER OR OWNER.

NO.	DESCRIPTION	DATE	BY

SCALE CHECK: THIS MARK SHOULD MEASURE EXACTLY 1" WHEN PLOTTED

NAG C-125BN OR APPROVED  
EQUAL LAID HORIZONTALLY  
ACROSS SIDE SLOPES

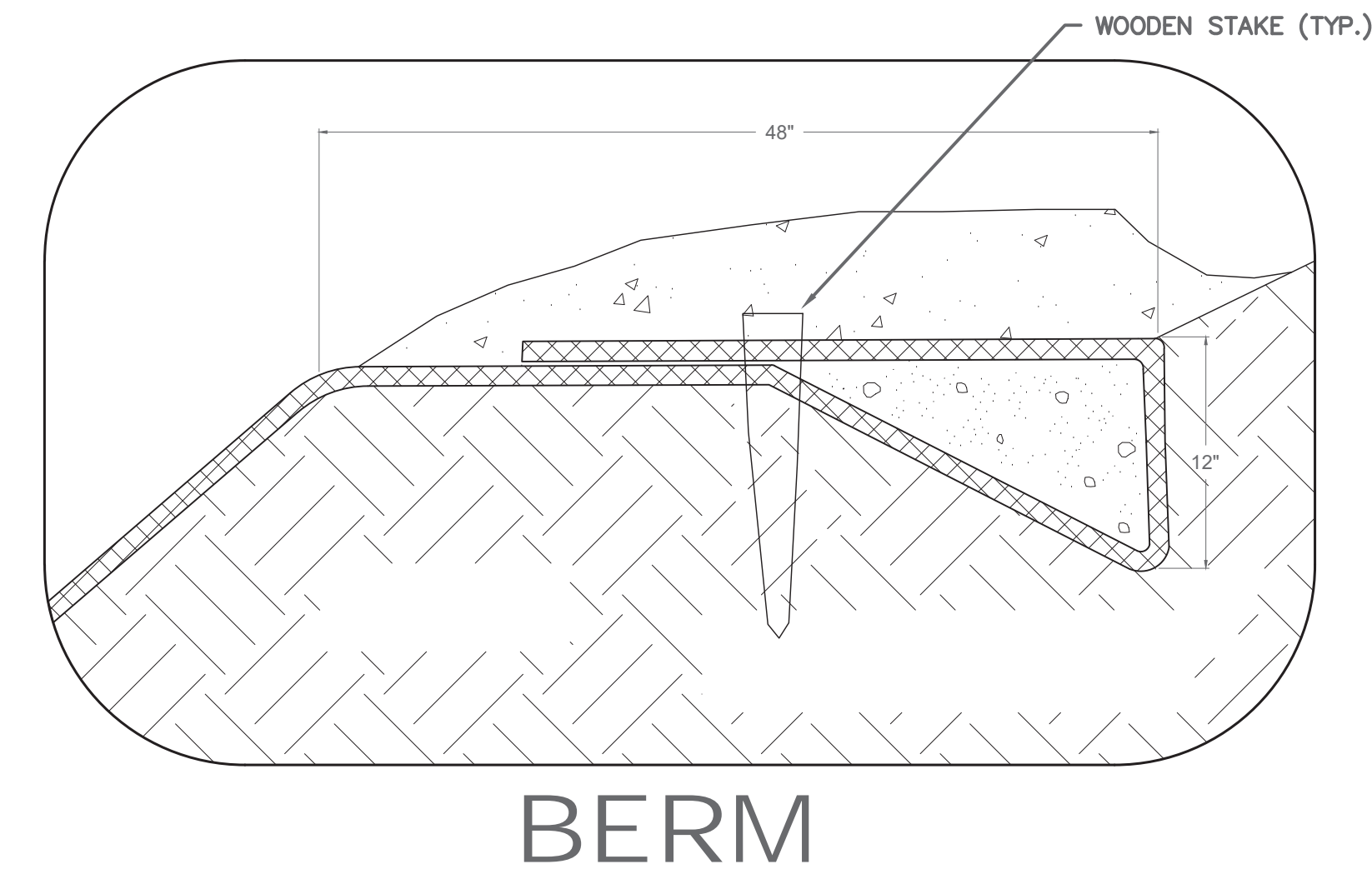
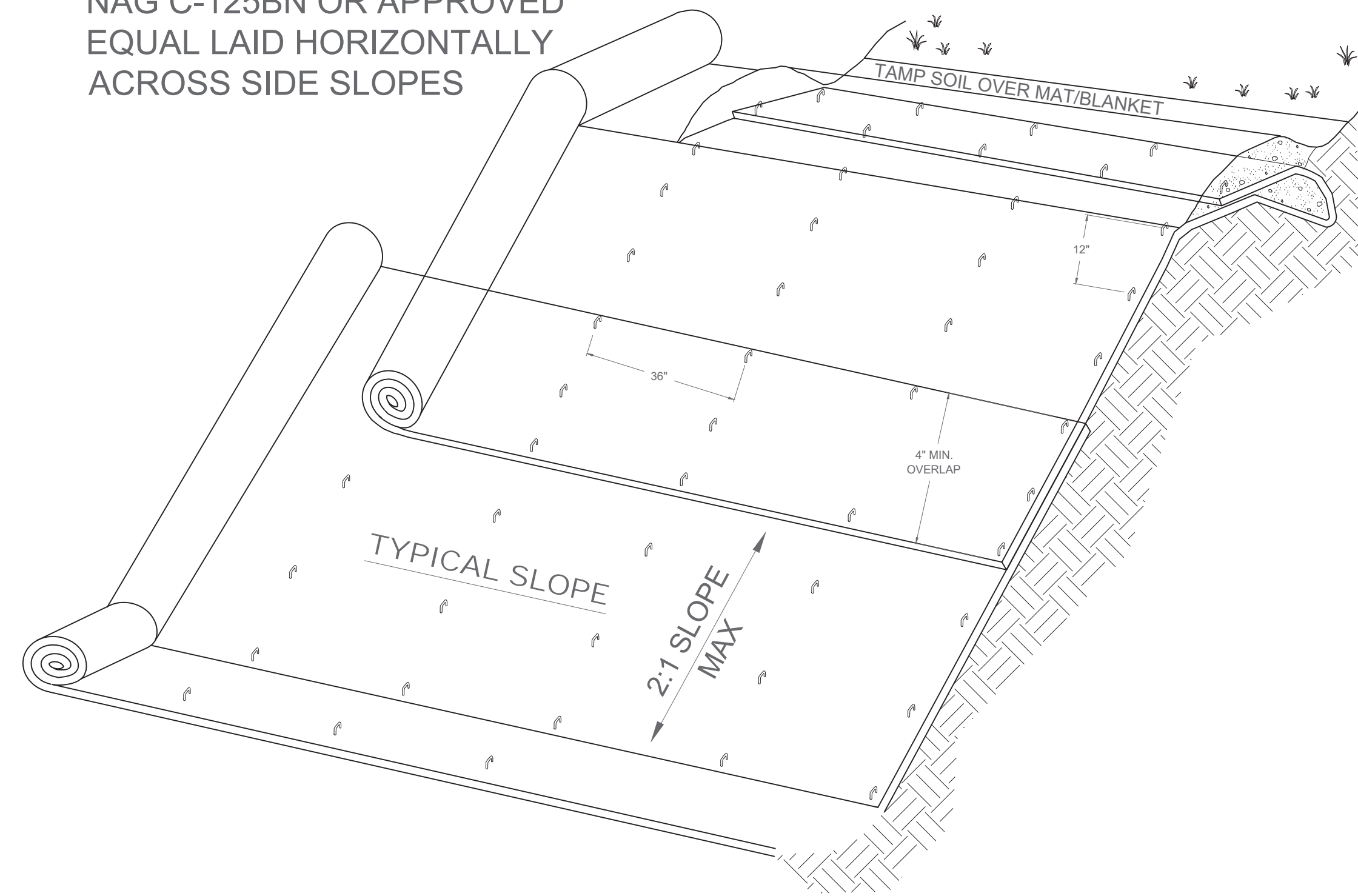

**EROSION CONTROL BLANKET INSTALLATION METHOD - NO SCALE**

**NOTES:**

1. SLOPE SURFACE SHALL BE FREE OF ROCKS, CLOUDS, STICKS AND GRASS. MATS/BLANKETS SHALL HAVE GOOD SOIL CONTACT.
2. APPLY PERMANENT SEEDING BEFORE PLACING BLANKETS.
3. LAY BLANKETS LOOSELY AND STAKE TO MAINTAIN DIRECT CONTACT WITH THE SOIL. DO NOT STRETCH.
4. SOIL LIFT WITH COMPACTED BACKFILL AND DOUBLE FABRIC LAYER SHALL BE PLACED ON STONE BASE. FABRIC SHALL BE FOLDED AT EACH BEND AS SHOWN IN PLAN VIEW. NO BEND SHALL EXCEED A 15 DEGREE ANGLE. FOLDS SHALL BE MADE IN AN UPSTREAM TO DOWNSTREAM DIRECTION. STAKE THE FOLDS AS SHOWN.
5. OUTER FABRIC ENDS SHALL BE JOINED BY LAPPING THE UPSTREAM PIECE OF FABRIC OVER THE DOWNSTREAM PIECE AS SHOWN IN PLAN VIEW. OVERLAPS SHALL BE A MINIMUM OF 3 FEET. INNER FABRIC ENDS SHALL BE BUTTED TOGETHER, NOT OVERLAPPED.
6. SECURE THE BANK SIDE EDGE OF THE OUTER FABRIC (WOVEN), WITH A WOODEN STAKE THROUGH THE FABRIC ON 3 FOOT CENTERS USING KEY TRENCH METHOD.
7. SECURE THE FABRIC WITH 8 INCH WOOD PEGS ON 3 FOOT CENTERS STAGGERED IN DIAMOND PATTERN

NO.	DESCRIPTION	DATE	BY

DATE: 9/21/2022  
SHEET NO. 10

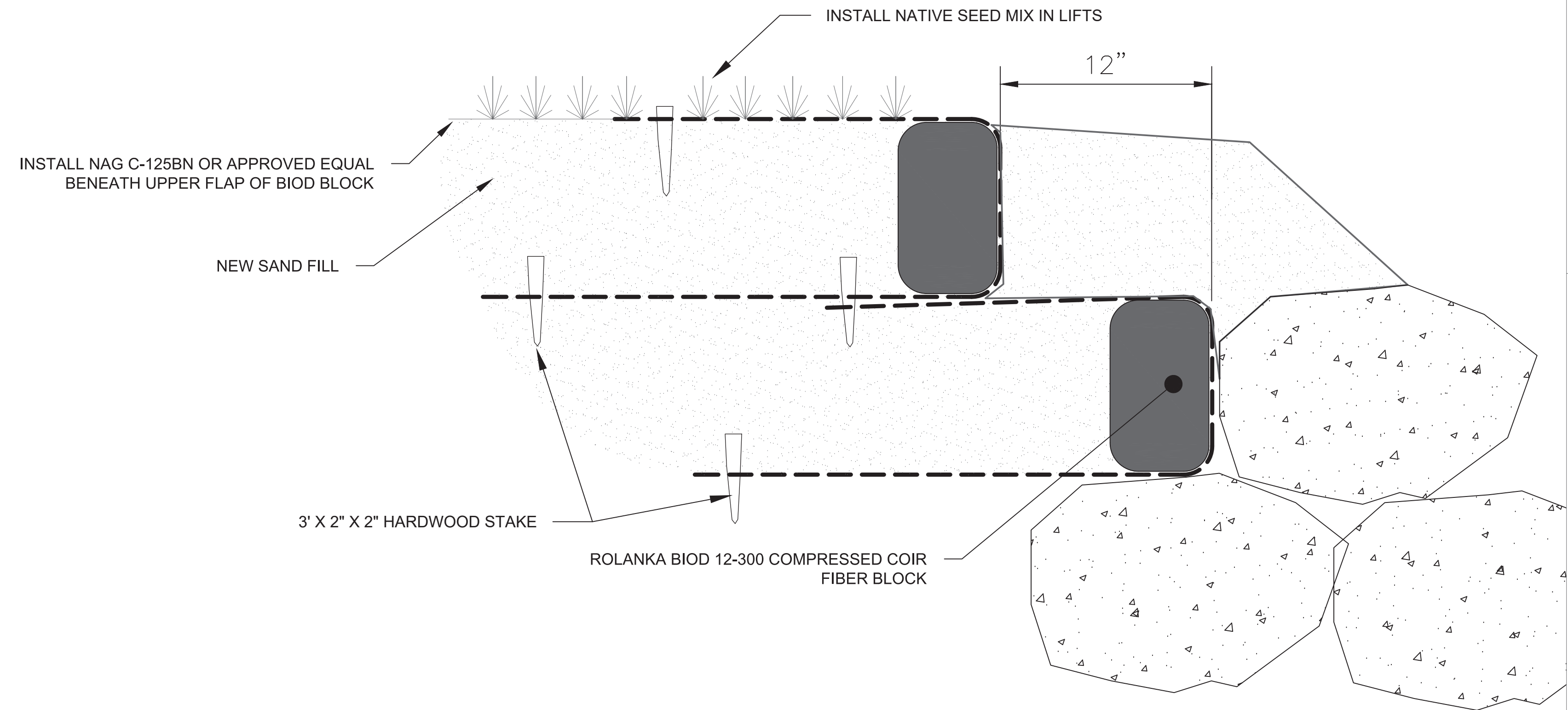
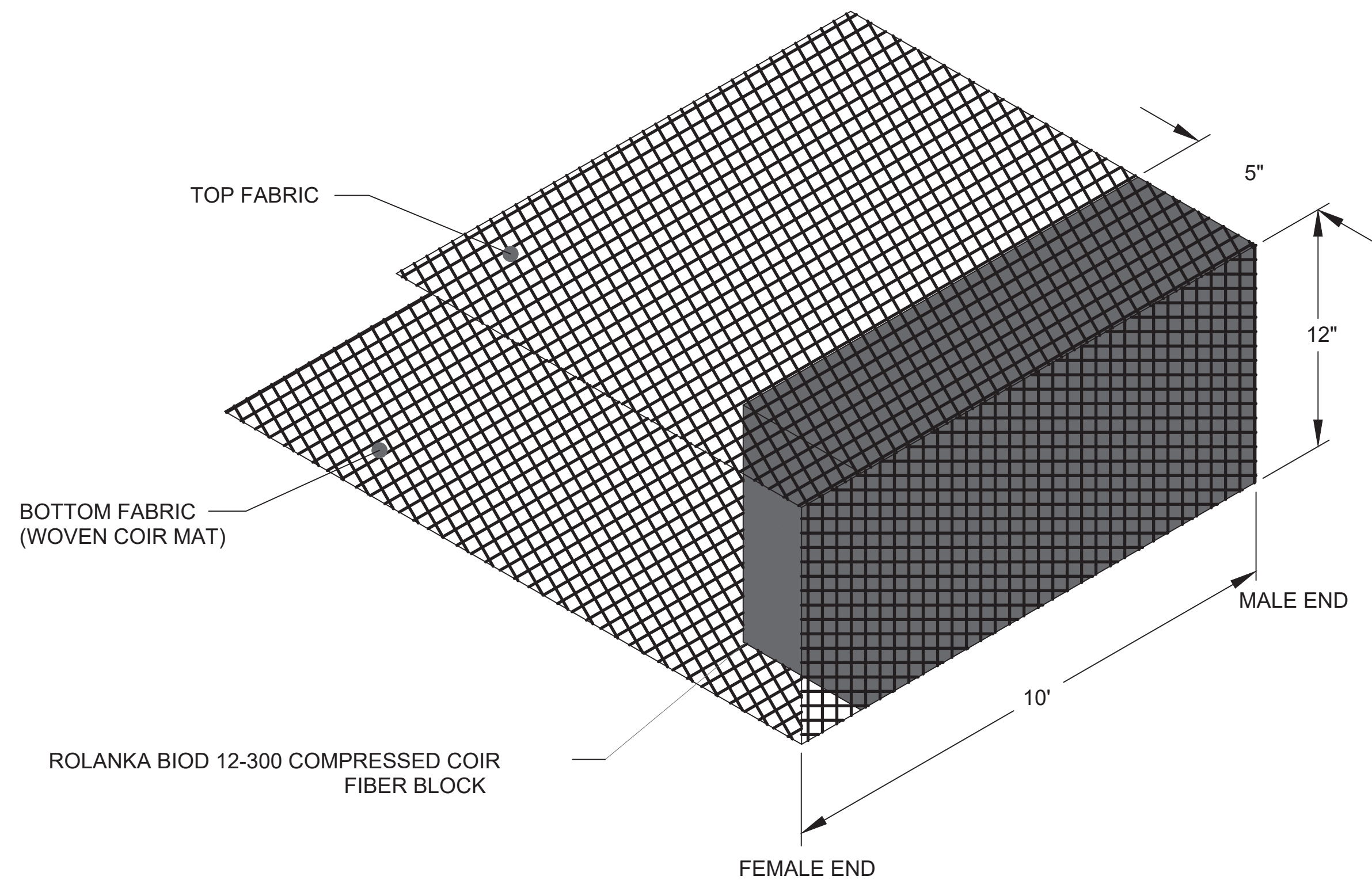

BIOD BLOCK INSTALLATION DETAIL

**NOTES**

1. FOLLOW MANUFACTURER'S INSTALLATION INSTRUCTIONS AND RECOMMENDATIONS.
2. USE LIVE PLANTS AND CUTTINGS OF THE SPECIES LISTED IN THE SPECIFICATIONS SHEETS.

NO.	REVISIONS DESCRIPTION	DATE	BY

DATE: 12/19/2022  
 SHEET NO. 11

SCALE CHECK: THIS MARK SHOULD MEASURE EXACTLY 1" WHEN PLOTTED

\\nasd\project\2000\20083-wendy\_nature\_based\_shoreline\civil\3d\2021\current\drawings\BHEETS\20083-2-Site\_Access\_Plan\_Wendy\_Park.dwg, Plotted: Dec 19, 2022 - 10:00am



PROJECT AREA

WHISKEY ISLAND DRIVE

**SITE ACCESS PLAN**



- NOTES**
- DATE OF AERIAL PHOTOGRAPHE: FALL 2021,  
[HTTPS://GIS.CUYAHOGACOUNTY.US/HTML5VIEWER/?VIEWER=CEGIS](https://gis.cuyahogacounty.us/html5viewer/?viewer=cegis)

**KS** Associates, Inc.  
260 Burns Road, Suite 100  
Elyria, OH 44035  
P 440 365 4730  
F 440 365 4790  
**KS ASSOCIATES** [www.ksassociates.com](http://www.ksassociates.com)

**Cleveland Metroparks**  
PROJECT NUMBER : 20083  
[www.clevelandmetroparks.com](http://www.clevelandmetroparks.com)

**SITE ACCESS PLAN**  
NATURE-BASED SHORELINE  
PROTECTION AT WENDY PARK  
2800 WHISKEY ISLAND DRIVE, OHIO 44102

NO.	DESCRIPTION	DATE	BY

DATE: 9/21/2022  
SHEET NO. 12

SCALE CHECK: [ ] THIS MARK SHOULD MEASURE EXACTLY 1" WHEN PLOTTED

R:\000000003-Wendy\_Park\_Nature\_Based\_Shoreline\_CIVIL\_3D\_2021\CURRENT DRAWINGS\SHEETS\0083-2\_Site\_Access\_Plan\_Wendy\_Park2.dwg, Plotted: Nov 14, 2022 - 4:01pm



**NOTES**

1. DATE OF AERIAL PHOTOGRAPHE: FALL 2021,  
[HTTPS://GIS.CUYAHOGACOUNTY.US/HTML5VIEWER/?VIEWER=CEGIS](https://gis.cuyahogacounty.us/html5viewer/?viewer=CEGIS)



KS Associates, Inc.  
 260 Burns Road, Suite 100  
 Elyria, OH 44035  
 P 440 365 4730  
 F 440 365 4790  
[www.ksassociates.com](http://www.ksassociates.com)

**STAGING AREA LOCATION**

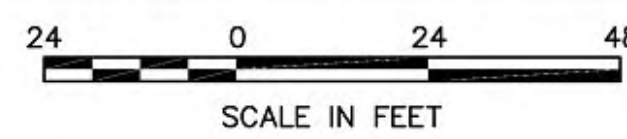

NO.	DESCRIPTION	DATE	BY

SCALE CHECK: \_\_\_\_\_ THIS MARK SHOULD MEASURE EXACTLY 1" WHEN PLOTTED

DATE: 9/21/2022  
 SHEET NO.:

**DIVISION 1 – GENERAL REQUIREMENTS**

**SECTION 01 30 01 – ADMINISTRATIVE PROVISIONS**

**PART 1 – GENERAL**

**1.1 REQUIREMENTS INCLUDED:**

- 1.1.1 Title of Work and Type of Contract
- 1.1.2 Contractor Use of Premises
- 1.1.3 Coordination
- 1.1.4 Reference Standards

**1.2 WORK COVERED BY CONTRACT DOCUMENTS:**

- 1.2.1 Base Bid: Work of this Contract comprises general construction nature-based shoreline of the project sites shown on the Contract Drawings, including the installation of ODOT Type "A" Armor Stone, vegetation seeding and plant plugs, Erosion Control Blanket, New Earth Fill, New Sand Fill, Toe Stones, and Soil Lifts, along with reinstallation and anchoring of the existing driftwood onsite.

**1.3 CONTRACT METHOD:**

- 1.3.1 Construct the work under lump sum and unit prices.
- 1.3.2 Owner will enter into separate contracts for work with the Contractor. The Contractor shall use the Contract forms provided by the Owner.

**1.4 CONTRACTOR USE OF PREMISES:**

- 1.4.1 Limit use of premises for work and for construction operations to the waterfront, park trails, parking lots, access corridors, and staging areas shown on the contract drawings. Contractor shall make arrangements with Owner for transportation of all construction materials and equipment to the site. All work and operations shall be coordinated with the Owner.
- 1.4.2 At the end of work by the Contractor, Contractor shall be responsible for all damages caused by construction of the project and shall be responsible for restoring any damaged areas to their original condition (before construction started). To facilitate determination of damages, contractor shall photograph work area with a digital camera or video camera prior to starting work and provide Owner with one set of digital photos or video tape.

**1.5 APPLICATION FOR PAYMENT:**

- 1.5.1 Submit one copy of each application under procedures of Section 01 33 01 on the form provided by the Owner.

**1.6 COORDINATION:**

- 1.6.1 Coordinate work of the various Sections of Specifications to assure efficient and orderly sequences of installation of construction elements, with provisions for accommodating items installed later.
- 1.6.2 Site access shall be provided at locations listed on the contract drawings.

**1.7 REFERENCE STANDARDS:**

- 1.7.1 For products specified by association or trade standards, comply with requirements of the standard, except when more rigid requirements are specified or are required by applicable codes.
- 1.7.2 The date of the standard is that which is in effect as of the Bid date.
- 1.7.3 Obtain copies of standards when required by Contract Documents. Maintain copy at jobsite during progress of the specific work.

**END OF SECTION**

**SECTION 01 31 19.13 – PRECONSTRUCTION CONFERENCE**

**PART 1 – GENERAL**

**1.1 REQUIREMENTS INCLUDED:**

- 1.1.1 Contractor participation in preconstruction conferences.

**1.2 RELATED REQUIREMENTS:**

- 1.2.1 Section 01 30 01 – Administrative Provisions.

**1.3 PRECONSTRUCTION CONFERENCE:**

- 1.3.1 Owner will coordinate with the contractor to schedule the conference at a mutually agreeable time.
- 1.3.2 Attendance: Owners or owners' representative, Engineer, Contractor and Subcontractors.
- 1.3.3 Agenda:
  - 1.3.3.1 Distribution of Contract Documents
  - 1.3.3.2 Submittal of list of Subcontractors, and construction progress schedule
  - 1.3.3.3 Designation of responsible personnel
  - 1.3.3.4 Procedures and processing of field decisions, submittals, substitutions, applications for payments, proposal requests, and change orders.

- 1.3.3.5 Scheduling.

**1.4 SUBMITTALS:**

**1.4.1 Preliminary Schedule:**

- 1.4.1.1 The selected Contractor is required to submit a written, preliminary schedule to the Engineer within 10 days after the Effective Date of the Contract indicating the times (numbers of days or dates) for starting and completing the various stages of the Work.
- 1.4.1.2 The Engineer and Owner are aware that schedules can change due to weather conditions at the project site and at the locations of other projects. Nevertheless, such uncertainties do not invalidate the requirement to provide a preliminary schedule. The Contractor may include a "subject to change" disclaimer on the preliminary schedule to account for uncertainties due to weather.
- 1.4.1.3 Refusal to provide a written, preliminary schedule to the Engineer in a timely manner is a failure to comply with a material term of the Contract Documents. The Contractor's failure to submit the required schedule in the time allotted, including submittals prior to items being incorporated in the work, will result in withholding of payment until such schedule and submittals are received and reviewed for acceptance.

- 1.4.2 Schedule of Values: Within 10 days after the notice of award, the Contractor shall submit to the Engineer for approval a preliminary Schedule of Values for all of the Work which includes quantities and prices of items which when added together equal the Contract Price and subdivides the Work into component parts in sufficient detail to serve as the basis for progress payments during performance of the Work.

**END OF SECTION**

**SECTION 01 33 01 – ADDITIONAL SUBMITTAL REQUIREMENTS**

**PART 1 – GENERAL**

**1.1 REQUIREMENTS INCLUDED:**

- 1.1.1 Procedures

**1.2 RELATED REQUIREMENTS:**

- 1.2.1 Section 00 62 76 – Application for Payment.

- 1.2.2 Section 01 30 01 – Administrative Provisions

**1.3 PROCEDURES:**

- 1.3.1 Deliver submittals to the Engineer at:
  - Mark P. Cencer P.E.,
  - KS Associates, Inc.
  - 260 Burns Road, Suite 100,
  - Elyria, OH 44035
  - Phone: 440-365-4730 ext. 395
  - Email: [cencerm@ksassociates.com](mailto:cencerm@ksassociates.com).
- 1.3.2 Physical samples, if any, shall be sent by mail or courier to the street address above. All other submittals shall be sent by e-mail to the e-mail address listed above.
- 1.3.3 Transmit each item under Engineer-accepted form. Identify the Project, Contractor, subcontractor, major supplier, referenced Drawing number, detail number and Specification Section number, as appropriate. Identify deviations from Contract Documents. Provide space for Contractor and Engineer review stamps.
- 1.3.4 After Engineer review of submittal, revise and resubmit as required, identifying changes made since previous submittal.
- 1.3.5 Distribute copies of reviewed submittals by e-mail to concerned persons. Instruct recipients to promptly report any inability to comply with provisions.

**END OF SECTION**

**SECTION 01 52 00 – CONSTRUCTION FACILITIES AND TEMPORARY CONTROLS**

**PART 1 – GENERAL**

**1.1 REQUIREMENTS INCLUDED:**

- 1.1.1 Sanitary Facilities
- 1.1.2 Electric Services
- 1.1.3 Water Service
- 1.1.4 Barriers
- 1.1.5 Security
- 1.1.6 Cleaning During Construction
- 1.1.7 Removals
- 1.1.8 Storage Areas

NO.	DESCRIPTION	DATE	BY



acts, shall not be construed to limit, affect, or impair the generality of the foregoing.

1.5.3 Should any part of this indemnification clause be held invalid; the remainder shall be in full force and effect.

**END OF SECTION**

**SECTION 01 71 13 – MOBILIZATION**

**PART 1 – GENERAL**

**1.1 WORK INCLUDED**

1.1.1 Work Included: This work shall consist of the performance of construction preparatory operations, including but not limited to the movement of personnel, equipment, materials to the project site. The contractor shall establish and maintain the necessary facilities to begin and sustain work on the Contract. In addition, the following items are to be included in the cost of mobilization:

- 1.1.1.1 Deliver necessary equipment as needed to complete the project. Coordinate with the Owner and Engineer for access roads and routes to the site, any roads damaged shall be repaired at the contractor's expense.
- 1.1.1.2 Prepare various plans and other items as necessary to facilitate work as outlined in the contract documents.
- 1.1.1.3 Recurring costs for record documentation for the duration of the project.
- 1.1.1.4 Other work items necessary to begin construction, as shown in the plans.
- 1.1.1.5 Executing temporary easements for site access.
- 1.1.1.6 Restroom facilities for construction team.
- 1.1.1.7 Demobilization efforts at completion of the Project.

1.1.1.8 Erosion and Sediment Control

**1.2 LIMITATION**

1.2.1 The owner will limit the sum of the partial payments to the amounts shown in the table below under "Maximum Total of Partial Payments". The owner will pay the balance of the lump sum amount bid, as specified in Part 1.4.1.3 below.

Total Contract Amount		Maximum Total of Partial Payments (\$)
More than (\$)	Up to, inclusive (\$)	
0	50,000	0
50,000	100,000	2,000
100,000	200,000	4,000
200,000	500,000	10,000
500,000	1,000,000	20,000
1,000,000	2,000,000	40,000
2,000,000	5,000,000	100,000

If the lump sum amount bid for Mobilization exceeds the total shown in the table above for partial payments, the owner will pay the excess upon completion of the project.

**1.3 METHOD OF MEASUREMENT**

1.3.1 The owner will measure mobilization as a unit, acceptably performed.

**1.4 PAYMENT**

1.4.1 The owner will make partial payments according to the following schedule:

- 1.4.1.1 The owner will release 50 percent of the lump sum amount bid for Mobilization or 50 percent of the amount shown in above part 1.2, Limitation, whichever is less, to the Contractor with the first estimate payable, but not sooner than 15 days after the start of work at the project site.
- 1.4.1.2 The owner will release an additional 40 percent of the lump sum amount bid for Mobilization or 40 percent of the amount shown in 1.2, whichever is less, with the first regular estimate after 10 percent of the original total contract amount, including payments for delivered materials but excluding Mobilization, is earned.
- 1.4.1.3 Upon completion of all work on the project, including final cleanup, the owner will release payment of the remaining 10 percent of the lump sum amount bid for Mobilization and any amount of the lump sum price bid for Mobilization, in excess of the total amount shown in 1.2 for partial payment. Final cleanup includes but is not limited to the removal of construction layout stakes and sediment and erosion control items.
- 1.4.1.4 Partial payments are subject to retainage per the contract.

**END OF SECTION**

**DIVISION 2 – EXISTING CONDITIONS**

**SECTION 02 93 00 – SITE RESTORATION**

**PART 1 – GENERAL**

**1.1 SECTION INCLUDES:**

- 1.1.1 The work shall consist of furnishing all labor, equipment and material necessary to finish grade, topsoil, seed, mulch, establish and maintain vegetation for the areas as specified herein.
- 1.1.2 All disturbed areas shall be top soiled and vegetated.
- 1.1.3 The contractor shall be responsible for all damages caused by construction of the project and shall be responsible for restoring any damaged areas to their original condition (before construction started).

**1.2 RELATED SECTIONS:**

- 1.2.1 Section 31 23 00 – Excavation, Grading, and Slope Preparation
- 1.2.2 Section 31 32 39 – Bioengineering Practices for Shoreline Stabilization

**1.3 SUBMITTALS:**

- 1.3.1 The Contractor shall submit a complete materials list of items proposed for the work and a description of how the work will be completed.
- 1.3.2 The Contractor shall submit seed certifications for all bags used in the project.

**1.4 DELIVERY, STORAGE AND HANDLING:**

- 1.4.1 Deliver grass and wildflower seed (if required) in original containers showing analysis of seed mixture, percentage of pure seed, year of production, net weight, date of packaging, and location of packaging. Damaged packages are not acceptable.

**1.5 MAINTENANCE:**

- 1.5.1 Maintain vegetated surfaces and supply additional topsoil where necessary, including areas affected by erosion.
- 1.5.2 Replant damaged grass areas showing root growth failure, deterioration, bare or thin spots, and eroded areas.
- 1.5.3 Water seeded areas as needed to promote growth as specified herein.

**1.6 PAYMENT:**

- 1.6.1 Payment for all work performed under this Section will be by lump sum bid price for Site Restoration.
- 1.6.2 Upon acceptable seeding, fertilizing and mulching phases of work as approved by the Engineer, fifty percent payment shall be made to the Contractor based on the division of contract price submitted.
- 1.6.3 Lime application per testing and will be paid on a per acre measurement.
- 1.6.4 Upon established grass as approved by the Engineer, the remaining fifty percent payment based on the division of contract price shall be made to the Contractor.

**PART 2 – PRODUCTS**

**2.1 SEED MIXTURE:**

- 2.1.1 The seed mixture for restoration of lawn and roadside areas shall be a mixture of 20% Kentucky 31 Fescue, 25% common Kentucky Bluegrass, 20% Manhattan Rye Grass, and 35% Creeping Red Fescue at the rate of eight (8) pounds per one thousand square feet (8:1000).
- 2.1.2 When specifically required, other areas shall be seeded with the native seed mix provided in Section 31 32 39, Bioengineering Practices for Shoreline Stabilization, Part 2, Products, Paragraph "Native Seed Mix".

**2.2 MULCH:**

- 2.2.1 Mulching material: Mulching material shall conform to ODOT CMS 659.
- 2.2.2 Establishment blanket: Uniform open weave jute matting; Excelsior matting; erosion control mulching fabric consisting of knitted construction of yard interwoven with strips of biodegradable paper; or organic fiber protective fiber mat consisting of half-inch layer of chopped straw, knitted into mat with thin netting of biodegradable polypropylene.

**2.4 TOPSOIL:**

- 2.2.1 Topsoil shall conform to ODOT CMS 653.
- 2.2.2 Topsoil shall be a minimum of 3" thickness, unless noted otherwise.

**PART 3 – EXECUTION**

**3.1 EXAMINATION:**

- 3.1.1 The Contractor shall not begin work in this section until the final grading has been approved by the Engineer.

**3.2 PREPARATION:**



PROJECT NUMBER : 20083  
www.clevelandmetroparks.com

**SPECIFICATIONS**  
**NATURE-BASED SHORELINE**  
**PROTECTION AT WENDY PARK**  
**2800 WHISKEY ISLAND DRIVE, OHIO 44102**

NO.	REVISIONS DESCRIPTION	DATE		BY
		DATE	DATE	

DATE: 12/19/2022  
SHEET NO. 16

3.1.1 The Contractor shall test the soil for the appropriate pH. The test results shall be submitted to the Engineer.

3.1.2 If needed, the Contractor shall apply agricultural liming material (amendments) as specified in Bulletin 472 "Agronomy Guide", published by the Cooperative Extension Service, The Ohio State University.

**3.3 APPLICATION GRASS SEED:**

3.3.1 The seeding shall be completed within three days after completion of final grading or as soon thereafter as conditions are favorable. Seeding shall occur between March 1 and October 30. Between October 30 and March 1, apply temporary seed according to ODOT Item 832.

3.3.2 The seedbed shall be prepared by pulverizing and breaking up the soil to a minimum depth of two inches with a disk harrow, drag harrow, spike tooth harrow or similar tool. All rocks over two inches in diameter, clods and undesirable material that would interfere with seeding operation shall be removed.

3.3.3 The grass seed shall be drilled or broadcast uniformly over the seedbed at a rate of 220 pounds per acre (5 pounds per 1,000 square feet) using methods and equipment acceptable to the Engineer. For wildflower seeding, plant at the rate specified by the manufacturer. The seeded area shall be passed over with a cultipacker or similar tool to help cover more seed and improve seeding establishment. Application of grass seed and fertilizer at the same time, in the same machine is not permitted.

3.3.4 Seed sowing is not permitted immediately following rain, when the ground is too dry, or during windy periods.

3.3.5 The approved mulch shall be applied over the seeded area at a rate of 2 tons per acre (one bale per 1,000 square feet) for straw. Hydro mulching will not be permitted.

3.3.6 The Contractor shall seed and mulch all disturbed areas.

3.3.7 Seeded areas shall be watered as necessary to promote good growth during the germination and establishment period. During the establishment period the Contractor shall water a minimum of one inch over the seeded area two times per week. In dry weather, more frequent watering will be required to provide a stand of grass.

**3.4 WATERING:**

3.4.1 Thoroughly water all permanent seeded areas (Classes 1 to 6) after the seed has germinated. Apply a total rate of 300 gallons per

1000 square feet in at least 2 applications spread over 7 days. Apply the water using a hydro-seeder or a water tank under pressure with a nozzle that produces a spray that will not dislodge the mulch material.

3.4.2 Perform a secondary water application between 7 and 10 days after the primary applications. If 1/2-inch (13 mm) or greater of rainfall has occurred within the first 7-day period, the Contractor may delay or omit the secondary application, depending on weather conditions.

**3.5 ADJUSTING:**

3.5.1 Any vegetated areas which are found to not have an adequate growth of cover during the first year shall be re-seeded as soon as weather conditions permit, at no additional cost to the Owner.

**3.6 INSTALLATION:**

3.6.1 The Contractor shall secure the work area and protect the vegetated areas until vegetation is accepted.

**END OF SECTION**

**DIVISION 31 – EARTHWORK**

**SECTION 31 05 22 – GEOTEXTILE FABRIC**

**PART 1 – GENERAL**

**1.1 WORK INCLUDED**

1.1.1 This item shall consist of furnishing all labor, equipment and materials necessary to install geotextile fabric below the Armor Stone and Toe Stone, where shown on the Contract Drawings.

**1.2 SUBMITTALS**

1.2.1 Submit manufacturer's literature and sample of geotextile fabric to the Engineer for approval prior to purchasing material.

1.2.2 The Contractor shall photograph its placement of the geotextile fabric in the locations shown on the Contract Drawings prior to the covering of the fabric with fill, stone, or other material. The Contractor shall submit the photographs to the Engineer upon request by the Engineer and Owner and with all pay requests that include geotextile fabric.

**1.3 MEASUREMENT AND PAYMENT**

1.3.1 Material will be measured for payment by the square yard of Geotextile Filter Fabric acceptably placed in the work area. Photographs of the geotextile placement as noted in "Submittals" above shall accompany all pay requests that include geotextile filter fabric.

**PART 2 – PRODUCTS**

**2.1 MATERIALS**

2.1.1 Geotextile fabric shall be a nonwoven, needle-punched polypropylene fabric with the following listed minimum properties:

Fabric Property	Test Method	Physical Property
Minimum tensile strength	ASTM D 4632	200 lbs.
Minimum elongation	ASTM D 4632	15%
Minimum puncture strength	ASTM D 6241	440 lbs.
Minimum tear strength	ASTM D 4533	50 lbs.
Apparent opening size	ASTM D 4751	24 mils
Minimum permittivity	ASTM D 4491	0.2 sec <sup>-1</sup>

**PART 3 - EXECUTION**

**3.1 SHIPMENT AND STORAGE**

3.1.1 During all periods of shipment and storage, the fabric shall be protected from direct sunlight, ultraviolet rays, temperatures greater than 140° F, mud, dirt, dust and debris. To the extent possible, the fabric shall be maintained wrapped in a heavy-duty protective covering.

**3.2 INSTALLATION**

3.2.1 The geotextile fabric shall be placed as shown on the Contract Drawings. At the time of installation, fabric shall be rejected if it has defects, rips, holes, flaws, deterioration, or damage incurred during manufacture, transportation or storage.

3.2.2 Overlap: Geotextile fabric shall be overlapped a minimum of two (2) feet at each seam.

**END OF SECTION**

**SECTION 31 10 00 – SITE CLEARING**

**PART 1 – GENERAL**

**1.1 WORK INCLUDED**

1.1.1 The work described in this section includes the removal of concrete debris, metallic debris, construction waste, and trash within the footprint of the new project features. The work described in this section also includes the removal of trees and vegetation marked for removal by the Owner and Engineer. Finally, the work described in this section includes the removal of driftwood for subsequent reinstallation after the new

sand fill has been installed per Section 31 23 00, Excavation, Grading, and Slope Preparation.

1.1.2 Section includes:

1.1.2.1 Clearing and grubbing.

1.1.2.2 Tree and shrub protection and removal.

1.1.2.3 Removal of debris related to clearing and grubbing operations.

**1.2 RELATED SECTIONS**

1.2.1 Section 31 23 00 – Excavation, Grading, and Slope Preparation

1.2.2 Section 31 32 39 – Bioengineering Practices for Shoreline Stabilization

1.2.3 Section 32 94 16 – Landscape Timbers

1.2.4 Section 35 31 19 – Stone Coastal Protection

**1.3 DEFINITIONS**

1.3.1 Caliper: Instrument used to measure tree diameter.

1.3.2 Clearing: Removal and disposal of above-ground items defined herein.

1.3.3 Grubbing: Removal and disposal of below-ground items defined herein.

**1.4 QUALITY ASSURANCE**

1.4.1 Comply with the requirements specified in the Contract Documents.

1.4.2 Permits:

1.4.2.1 See General Conditions for additional requirements.

**1.5 DELIVERY STORAGE AND HANDLING**

1.5.1 Comply with the requirements specified in the Contract Documents.

**1.6 SITE CONDITIONS**

1.6.1 Existing facilities, structures, and utilities are shown in accordance with available surveys and records. The indicated locations of underground utilities and structures are approximate. Other utilities may exist that are not indicated.

**PART 2 – PRODUCTS**

**2.1 ACCESSORIES**

2.1.1 Herbicides: The Contractor is not allowed to use herbicides unless written permission has been granted by the Owner.



PROJECT NUMBER : 20083  
www.clevelandmetroparks.com

**SPECIFICATIONS**  
**NATURE-BASED SHORELINE**  
**PROTECTION AT WENDY PARK**  
**2800 WHISKEY ISLAND DRIVE, OHIO 44102**

NO.	REVISIONS DESCRIPTION	DATE	BY

DATE: 12/19/2022  
SHEET NO. 17

2.1.2 Tree Wound Paint: Bituminous based paint formulated for tree wounds.

**PART 3 – EXECUTION**

**3.1 EXAMINATION**

- 3.1.1 Verify survey benchmarks and intended elevations for the Work are as indicated.
- 3.1.2 Verify temporary erosion and sediment control measures are installed before commencing with other work at the site.
- 3.1.3 Verify location and existence of underground utilities and structures by contacting utility OWNERS. Go to "Call Before You Dig" to receive state-specific information. Access this information by dialing 811 or going to <http://call.811.com/state-specific.aspx>.
- 3.1.4 Provide 72-hour notice to existing utility owners prior to beginning construction.
- 3.1.5 Contact utility companies and authorities to make arrangements for handling and disposal of utilities encountered during construction.

**3.2 PREPARATION**

- 3.2.1 Protect benchmarks, survey control points, and existing structures to remain from damage or displacement.
- 3.2.2 Do not cut or injure trees and vegetation outside easement lines and outside designated clearing areas. Protect trees and vegetation to remain.
- 3.2.3 Protect underground utilities and structures that are to remain. If damage occurs, immediately notify the utility owner within the hour.
- 3.2.4 Protect site features to remain from damage by construction equipment and vehicular traffic.
- 3.2.5 Identify waste and salvage areas for stockpiling of removed materials.

**3.3 RESTORATION**

- 3.3.1 Existing surfaces, features, utilities, or structures that are to remain but are damaged during construction shall be restored to at least the condition in which they were found immediately before work began, unless noted otherwise.
- 3.3.2 Restore damaged utilities to the satisfaction of the utility owner.
- 3.3.3 Restore damaged private property to the satisfaction of the property owner.

**3.4 CLEARING**

- 3.4.1 Remove and dispose offsite:

3.4.1.1 Downed timber and decayed wood landward of the vegetation line along the beach, along with trees and vegetation marked for removal by the Owner and Engineer.

3.4.1.2 All concrete not attached to the existing sheet pile bulkheads, metallic debris, construction waste, trash, refuse, and rubbish. Remove evidence of their presence from the surface.

3.4.1.3 Rocks larger than 6 inches that are unsuitable for re-use as Toe Stone or Natural Stone Stabilization Rock as outlined in Part 2 of Section 35 31 19, Stone Coastal Protection.

3.4.2 Driftwood on the beach lakeward of the vegetation line shall be removed from the beach and set aside as noted in "Driftwood, Tree, and Shrub Removal" below.

3.4.3 Clear ground within limits of work and width of permanent or temporary easements, unless otherwise noted.

3.4.4 Manual cutting of trees, stumps, and stubs during clearing shall be as close to ground surface as practicable but no higher than 6 inches above ground for small trees (8 inches or less), and not higher than 12 inches above ground for larger trees (greater than 8 inches).

3.4.5 Obey federal, state and local regulations and guidance regarding the cutting, burning, and disposal of diseased trees and vegetation

**3.5 GRUBBING**

3.5.1 Remove and dispose of the following materials offsite:

3.5.1.1 Stumps;

3.5.1.2 Buried logs;

3.5.1.3 Matted roots;

3.5.1.4 Roots larger than 2 inches;

3.5.1.5 Organic materials; and,

3.5.1.6 Buried rocks and buried concrete fragments unsuitable for re-use as Toe Stone or Natural Stone Stabilization Rock as outlined in Part 2 of Section 35 31 19, Stone Coastal Protection.

3.5.2 Roots larger than 2 inches in diameter shall be removed to a depth of 12 inches or the depth of excavation noted on the Contract Drawings, whichever is lower. Roots larger than 1/2-inches in diameter to a depth of 6 inches or the depth of excavation noted on the Contract Drawings, whichever is lower.

3.5.3 Depressions made by grubbing shall be filled with suitable material and compacted to conform to original adjacent grade.

3.5.4 Do not grub areas within drip line of trees to remain, if any, to avoid damage to roots.

**3.6 ROCK RE-USE**

3.6.1 Rock that meets the requirements for Toe Stone or ODOT Type "A" Armor Stone as outlined in Part 2 of Section 35 31 19, Stone Coastal Protection may be set aside and stockpiled for reuse as Toe Stone or ODOT Type "A" Armor Stone. All other rock and all concrete debris shall be disposed of offsite as noted in above Part 3.4, Clearing.

**3.7 DRIFTWOOD, TREE, AND SHRUB REMOVAL**

3.7.1 Remove trees and shrubs within work limits as indicated on Contract Documents by felling or cutting individual vegetation and grubbing.

3.7.2. All existing driftwood within the limits of the ODOT Type "A" Armor Stone, Erosion Control Blanket, New Earth Fill, Toe Stones, Stabilized Bank, and Soil Lifts shall be removed from the beach and set aside in the staging and storage area shown on the Contract Drawings or designated by the Owner for reinstallation per Section 32 94 16, Landscape Timbers.

**3.8 TREE AND SHRUB PROTECTION**

3.8.1 Protect and prune OWNER-designated trees and shrubs within the work limits.

**3.9 PRUNING**

3.9.1 Trim dead branches 1-1/2-inches or more in diameter and branches to heights and in a manner as indicated. Neatly cut limbs and branches close to the bole of the tree or main branches. Paint cuts more than 1-1/4-inches in diameter tree wound paint.

**3.10 BURNING**

3.10.1 Burning is not permitted on site.

**3.11 CLEANING**

3.11.1 Promptly dispose of excess and unsuitable material off site.

3.11.2 Remove debris, junk, and trash from site.

3.11.3 Leave site in clean condition, ready for subsequent work.

3.11.4 Clean up spillage and wind-blown debris before entering public or private property adjacent to the project site.

**END OF SECTION**

**SECTION 31 23 00 – EXCAVATION, GRADING, AND SLOPE PREPARATION**

**PART 1 – GENERAL**

**1.1 WORK INCLUDED**

- 1.1.1 Excavation, grading, and slope preparation shall include:
  - 1.1.1.1 Excavation of all sand and gravel in the footprint of the proposed Toe Stone and ODOT Type "A" Armor Stone for entrenchment of those structures with sidecasting of the material lakeward.
  - 1.1.1.2 Placement of the New Earth Fill and New Sand Fill as shown on the Contract Drawings.
  - 1.1.1.4 Installation of the Soil Lifts as shown on the Contract Drawings.

**1.2 RELATED SECTIONS**

- 1.2.1 Section 02 93 00 – Site Restoration
- 1.2.2 Section 31 10 00 – Site Clearing
- 1.2.3 Section 31 32 39 – Bioengineering Practices for Shoreline Stabilization
- 1.2.4 Section 32 94 16 – Landscape Timbers
- 1.2.5 Section 35 31 19 – Stone Coastal Protection

**1.3 EXISTING CONDITIONS**

- 1.3.1 The Contractor should anticipate the removal of non-soil material including concrete debris, waste lumber, other wood debris, trash, rock, etc. per Section 31 10 00, Site Clearing. No additional payment will be provided for removals as listed above.
- 1.3.2 The Contractor shall be aware that the geotechnical information specific to the project site is not readily available. The Contractor shall account for this uncertainty when preparing its bid and planning the work.
- 1.3.3 Conduct excavation, grading and slope preparation within the construction limits to minimize interference with adjacent structures.

**1.4 SUBMITTALS**

- 1.4.1 Submit photographs of sidecasting sand and gravel and the placement of sand prefill as required by the regulatory permits.
- 1.4.2 Submit copies of weight tickets and receipts for the materials described under Part 2 with the applications for payment. Payment for the work described in this

NO.	REVISIONS DESCRIPTION	DATE	BY

section will not be made without the corresponding weight tickets and receipts.

1.4.3 For each material described under Part 2, the Contractor shall submit to the Engineer for approval certified reports of inspections and laboratory tests, prepared by an independent testing agency. Each report shall be properly identified. Test methods used and compliance with recognized test standards shall be described. The reports shall be submitted to the Engineer for approval prior to delivery to the project site and shall include:

- 1.4.3.1 Name, address, telephone number, e-mail address, and point of contact for the material source.
- 1.4.3.2 Sieve analyses.
- 1.4.3.3 Geotechnical analyses confirming the Liquid Limit, Plastic Limit, pH, and Unified Soil Classification.

Material delivered or placed prior to the receipt and approval of the above information that does not meet the requirements of Part 2 shall be removed from the site at the Contractor's expense.

**1.5 PAYMENT**

1.5.1 Payment for all work performed under this section will be by the unit price bid items for New Earth Fill, New Sand Fill, and Soil Lifts.

**PART 2 – PRODUCTS**

**2.1 GENERAL**

2.1.1 All construction fill material shall be free of oil and grease, debris, wood, concrete, general refuse, plaster, and other pollutants and shall contain no broken asphalt.

**2.2 NEW EARTH FILL**

2.2.1 The New Earth Fill shall be a mixture of gravel, sand, silt, and clay conforming to the following gradation:

Grain Size (mm)	Percent Passing
76 (3")	100
2.00	63 to 77
0.42	20 to 62
0.074	6 to 25
0.005	6 to 16

**2.3 FILL FOR SOIL LIFTS**

2.3.1 Fill for the soil lifts shall meet the same requirements as the New Earth Fill.

**2.4 NEW SAND FILL**

2.4.1 The New Sand Fill shall be granular material conforming to the following gradation:

Sieve Size		Percent Passing	
No.	(mm)	Min.	Max.
3/8 inch	9.53	100	100
No. 4	4.75	80	100
No. 8	2.36	60	100
No. 16	1.18	35	85
No. 30	0.60	10	70
No. 50	0.30	0	35
No. 100	0.150	0	10
No. 200	0.075	0	2

**PART 3 – EXECUTION**

**3.1 EXCAVATION**

- 3.1.1 Conduct excavation, grading, and slope preparation within the construction limits to minimize interference with adjacent structures.
- 3.1.2 Excavate to the grades shown on the Contract Drawings, and grade and slope as necessary.
- 3.1.3 All excavated sand and gravel in the footprint of the Toe Stone and ODOT Type "A" Armor Stone shall be sidecast lakeward. All other excavated material shall be disposed of offsite at the Contractor's expense at a suitable upland facility, unless otherwise shown on the Contract Drawings.

**3.2 STOCKPILES**

3.2.1 Stockpiles of all material to be incorporated into the work shall be kept in a neat and well drained condition, giving due consideration to drainage at all times. The ground surface at stockpile locations shall be cleared, grubbed, and sealed. Topsoil shall be stockpiled separately from suitable backfill material. Stockpiles of aggregates and granular soils shall be protected from contamination which may destroy the quality and fitness of the stockpiled material. If the Contractor fails to protect the stockpiles, and any material becomes frozen, saturated, intermixed with other materials, or otherwise out of specification or unsatisfactory for the use intended, such material shall be removed and replaced with new material from approved sources at no additional cost to the Owner.

**3.3 FILL PLACEMENT**

- 3.3.1 Do not place material on surfaces that are muddy, frozen, contain frost, or where unsatisfactory material remains in or under the fill.
- 3.3.2 Moisture Control: Control of moisture in the fill shall be maintained to provide acceptable compaction. Moisture

content of cohesive soils shall be adjusted before placement. Adding water directly to the reinforced fill zone shall only be conducted under conditions where the soil has sufficient porosity and capillarity to provide uniform moisture throughout the fill during compaction.

3.3.3 Construction Tolerances:

- 3.3.3.1 Horizontal: The slope crest and toe shall be within 6 inches of the plan location.
- 3.3.3.2 Vertical: The slope crest elevations shall be within 0.3 feet above to 0.3 feet below the prescribed elevations shown on the Contract Drawings.

**3.4 PROTECTION OF WORK**

3.4.1 Work shall be protected against damage from subsequent operations.

**END OF SECTION**

**SECTION 31 25 00 – EROSION & SEDIMENTATION CONTROL**

**PART 1 – GENERAL**

**1.1 WORK INCLUDED**

- 1.1.1 This item shall consist of furnishing all labor, equipment and materials necessary to install, maintain and remove upon completion of the project all Storm Water Pollution Prevention (SWPP) measures.
- 1.1.2 The Erosion and Sedimentation Control Drawings shown in the Contract Drawings, if any, are the minimum requirement to be implemented. Provide additional control as necessary to meet applicable local and State criteria or as required to complete the work.

**1.2 RELATED WORK**

1.2.1 Section 31 23 00 – Excavation, Grading, and Slope Preparation

**1.3 SUBMITTALS**

- 1.3.1 If required, the Contractor shall be responsible for submitting all required notices to the regulatory agencies per the regulatory permits prior to commencing work. The proposed work is anticipated to require disturbance of less than one acre.
- 1.3.2 Submit for approval by the Engineer complete manufacturer's published descriptive literature and specifications for all products specified herein and utilized on the project.
- 1.3.3 Submit a written SWPP Plan to the Engineer and Owner for approval no less than 5 business days prior to commencing work onsite.

**1.4 QUALITY ASSURANCE**

- 1.4.1 Regulatory Requirements: Comply with applicable local, State and Federal ordinances, rules and regulations concerning sedimentation control and storm water runoff.
- 1.4.2 In case of conflict between the above codes, regulations, references and standards and these specifications, the more stringent requirements shall govern.

**1.5 PROJECT SITE CONDITIONS**

1.5.1 Existing Conditions: Verify all existing conditions affecting the work of this section prior to submitting bids or proposals. Additional compensation will not be allowed for revisions or modification of work resulting from failure to verify existing conditions.

**1.6 MAINTENANCE REQUIREMENTS**

1.6.1 Temporary Erosion and Sediment Control measures shall be maintained until permanent measures are in place or no longer necessary due to project completion. All damaged, disturbed or devices filled with sediment, which may occur within the construction period, shall be corrected at no cost to the Owner. Any devices damaged by erosion or sediment shall be restored to their original condition by the Contractor, at no cost to the Owner.

**PART 2 – PRODUCTS**

**2.1 SILT FENCE**

2.1.1 Silt fence shall be furnished and installed around the perimeter of all material staging areas as specified on the Contract Drawings.

**PART 3 – EXECUTION**

**3.1 EROSION & SEDIMENTATION CONTROL**

- 3.1.1 The Contractor shall perform all items specified in the Contractor's SWPP Plan to prevent soil erosion and discharge of soil-bearing water runoff or airborne dust to adjacent properties. Including the prevention of soil, silts, organics entering catch basins around and near the site.
- 3.1.2 Inspect, repair, and maintain erosion and sedimentation control measures during construction until permanent vegetation has been established.
- 3.1.3 Remove erosion and sedimentation controls and restore and stabilize areas disturbed during removal.

**END OF SECTION**

NO.	DESCRIPTION	DATE	BY



19.13, Preconstruction Conferences. Work shall not commence without the approval of the schedule and construction sequence by the Contracting Officer. Construction shall not occur if climatic conditions threaten the survivability of plants or worker safety.

**1.9 WARRANTY**

1.9.1 The bioengineered features and structures and all manufactured materials shall be under Contractor warranty for a period of 2 years including vegetation and earthworks. Stone and rock shall be under warranty from decomposition for 5 years.

**1.10 MAINTENANCE**

1.10.1 General: Include in maintenance eradicating weeds; protecting embankments and ditches from surface erosion; maintaining the performance of the erosion control materials and mulch; replacement of dead or non-viable plants; repair of soil, stone, rock, or hard structures, and protecting installed bioengineered features and structures from human and animal activities.

1.10.2 Maintenance Instructions: Furnish written instructions containing drawings and other necessary information to the Engineer describing the care of the installed material, including when and where maintenance should occur and the procedures for material replacement. Submit instruction for year-round care of installed products including schedule, materials, and tasks. Instructions shall describe the methods for specific maintenance activities and equipment and tools required for such efforts. Requirements on safety and regulations and permits shall be included.

**PART 2 – PRODUCTS**

**2.1 BINDERS**

2.1.1 Submit certification for binders showing EPA registered uses, toxicity levels, and application hazards. Prior to delivery of materials, submit certificates of compliance attesting that those materials meet the specified requirements and certified copies of the material certificates. All binders shall be biodegradable and untreated hemp or coir rope or fasteners, which shall be able to withstand 2 years minimum exposure to the environment of placement without significant degradation in strength or quality. Steel or plastic binders or fasteners shall not be used.

**2.2 EROSION CONTROL ITEMS**

2.2.1 Provide erosion control products as shown on the Contract Drawings. Install materials according to manufacturer's recommendations based on actual site conditions and as shown on the Contract Drawings.

**2.3 NATIVE SEED MIX**

2.3.1 The Native Seed Mix shall be supplied as pure live seed (PLS) based on the following proportions:

Scientific Name	Common Name	PLS Oz Per Acre
<i>Andropogon virginicus</i>	Broom sedge	12
<i>Asclepias incarnata</i>	Swamp milkweed	2
<i>Calamagrostis canadensis</i>	Blue-joint	1
<i>Carex comosa</i>	Bristly sedge	1
<i>Carex crinita</i>	Fringed sedge	1
<i>Carex cristatella</i>	Crested oval sedge	1
<i>Carex emoryi</i>	Riverbank sedge	1
<i>Carex frankii</i>	Frank's sedge/ bristly cattail sedge	1
<i>Carex granularis</i>	Pale sedge	1
<i>Carex hystericina</i>	Porcupine sedge	1
<i>Carex lurida</i>	Bottlebrush sedge	4
<i>Carex vulpinoidea</i>	Brown fox sedge	8
<i>Doellingeria umbellata</i>	Flat-topped white aster	1
<i>Elymus riparius</i>	Riverbank wild rye	16
<i>Elymus virginicus</i>	Virginia wild rye	16
<i>Eupatorium perfoliatum</i>	Common boneset	1
<i>Glyceria striata</i>	Fowl manna grass	1
<i>Heliopsis helianthoides</i>	False sunflower	4
<i>Iris versicolor</i>	Blue flag iris	1
<i>Juncus effusus</i>	Common rush	4
<i>Juncus torreyi</i>	Torrey's rush	0.5
<i>Lobelia cardinalis</i>	Red lobelia/ cardinal flower	0.25

**2.4 TEMPORARY GRASS COVER**

2.4.1 Temporary Grass Cover shall be supplied as pure live seed (PLS) based on the following proportions:

Scientific Name	Common Name	PLS Oz. Per Acre
<i>Avena sativa</i>	Seed oats	80
<i>Lolium multiflorum</i>	Annual rye	300
	Total PLS Ounces Per Acre	380
	Total PLS Pounds Per Acre	23.75

**2.5 NATIVE PLANT PLUGS**

2.5.1 Native Plant Plugs shall be 38-cell size or approved equal and installed within 12" in elevation of the water line or where shown on the Contract Drawings. Plugs shall be spaced 2 feet apart on-center. The plugs shall the following species:

Scientific Name	Common Name	PLS Oz Per Acre
<i>Lobelia inflata</i>	Indian tobacco	0.25
<i>Lobelia siphilitica</i>	Great blue lobelia	0.25
<i>Lycopus americanus</i>	Common water horehound	2
<i>Monarda fistulosa</i>	Wild bergamot	4
<i>Rudbeckia hirta</i>	Black-eyed Susan	2
<i>Scirpus atrovirens</i>	Dark green rush	1
<i>Scirpus cyperinus</i>	Wool grass	2
<i>Solidago rugosa</i>	Rough goldenrod	2
<i>Symphotrichum novae-angliae</i>	New England aster	1
<i>Zizia aurea</i>	Golden Alexanders	0.5
	Total PLS Ounces Per Acre	93.75
	Total PLS Pounds Per Acre	5.86

Common Name	Scientific Name	Percentage
<i>Iris versicolor</i>	Blue Flag Iris	25%
<i>Juncus effusus</i>	Common rush	25%
<i>Schoenoplectus tabernaemontani</i>	Softstem bulrush	50%

2.5.2 Submit classification, botanical name, common name, harvest location, plant health, and date tested for the plant plugs.

2.5.3 Neither non-native nor invasive vegetation species are allowed. All plant plugs shall be capable of growth and rooting and free of disease or defects at the time of installation.

**2.6 LUMBER STAKES**

2.6.1 Lumber stakes shall be 100 percent biodegradable materials and shall be designed to safely and effectively secure erosion control blankets, coir logs, fascines, and other bioengineered features and structures for temporary or permanent applications. The stakes must exhibit ample rigidity to enable being driven into hard ground, with sufficient flexibility to resist shattering.

**2.7 STAPLES**

2.7.1 Do not use metal or plastic staples.

**2.8 SYNTHETIC GRID AND SHEET SYSTEMS**

2.8.1 Do not use synthetic grid and sheet systems.

**2.9 NEW EARTH FILL AND NEW SAND FILL**

2.9.1 The quality of New Earth Fill and New Sand Fill shall be in accordance with requirements in Section 31 23 00, Excavation, Grading, and Slope Preparation. Materials not meeting specified requirements shall be rejected and immediately replaced by suitable material at no cost to the Owner.

**2.10 WATER**

2.10.1 Water for irrigation, soaking of plants and cuttings and native plant plugs, and dust control shall be the responsibility of the Contractor. Water shall be clean, free of contaminants, and have a turbidity of less than 20 NTU. Water shall be from a local water source or from the lake.

**2.11 WILDLIFE FENCE**

2.11.1 The Wildlife Fence shall be temporary and consist of the following:

2.11.1.1 Fence: Tenax 2A140073 Pet Fence or Engineer-approved equal.

NO.	REVISIONS DESCRIPTION	DATE	BY



shall be compacted sufficiently to improve soil density but not impede vegetation root growth.

3.2.4.3.1 Slopes on new fill greater than 3H:1V shall be roughened by the installation of lifts of compacted soil that shall not exceed 8 inches in thickness.

3.2.4.3.2 The existing slope of graded areas shall be roughened by tilling, disking, harrowing and seeding, or other suitable method or equipment to produce ridges and depressions in the surface of the slope, which are parallel to the contours of the slope. These ridges and depressions shall not exceed 1 inch in depth or height above the grade surface and shall be spaced no more than 10 inches apart.

3.2.4.3.3 The final roughened surface shall not be smoothed by blading or scraping. All large soil clumps shall be broken into small clumps not more than 2 inches in diameter and dispersed on the immediate surface. Mounds or depressions of soil that are greater in height or depth than those produced by the method of roughening shall be cut or filled with suitable material to grade and shall be roughened to match the adjacent surface. Depressions of depth greater than 6 inches shall be backfilled with compacted suitable material until reaching the design grade of the slope and roughened. Sand or silty sand shall not be compacted to a density that may prevent vegetation planting and growth. Roughened areas shall be seeded, planted, or covered with erosion control products immediately after roughening.

**3.3 FIRE PREVENTION**

3.3.1 All efforts possible shall be taken to prevent fire at the work site and harvest area as a direct result of work efforts. Fire prevention or suppression equipment shall be provided to personnel at the work and harvest sites. All equipment shall be in compliance with applicable regulations and shall be kept in working condition at all

times and within no more than 15 feet distant from the active work areas.

**3.4 SANITATION**

3.4.1 Provide adequate portable sanitation facilities for persons at the construction and harvest sites that are in compliance with all Federal, State, and local requirements.

**3.5 TIME OF PLANTING**

3.5.1 Native Plant Plugs: Installation of native plant plugs shall occur no earlier than May 1 and shall be completed no later than August 1.

3.5.2 All other vegetation: Planting shall occur in the spring starting no earlier than March and shall be completed by no later than September.

**3.6 TRANSPORTATION AND STORAGE OF PLANT MATERIAL**

3.6.1 Live vegetation shall be transported from the staging area to the work site in containers fully covered with clean water. Vegetation shall be removed from the containers and immediately placed in the ground. In the event that access to the installation site is limited, vegetation shall be removed from the soaking tanks and wrapped in bundles that are completely covered with at least three layers of saturated highly absorbent cloth or saturated biodegradable paper product with high saturated strength. The cloth and bundles shall be placed in plastic liners for greater ease in transportation to the work site.

3.6.2 Herbaceous plants and nursery stock shall be transported to the work site in covered vehicles. Plants shall not be subjected to cold or excessive heat or drying during transport. The plants shall be carefully unloaded at the staging area and placed in a shaded area. Plants shall be watered and maintained in healthy condition until the time of installation. The plants shall be transported to the work site and immediately installed at the site. Damaged, wilted, diseased, or dead plants or nursery stock shall not be accepted and shall be immediately replaced at no expense to the Owner.

**3.7 STAGING AREA**

3.7.1 A staging area shall be constructed at the work site for the storage of equipment, work trailer, portable sanitation, water tanks, parking, and all other materials and equipment required to complete the work. The site should have a level portion for the placement of soaking tubs for the live vegetation. The staging area shall be secured by an eight feet high chain link security fence to prevent vandalism or unauthorized access to the staging area. Adequate surface preparation shall be performed to prevent excessive settlement, ponding of water, or rutting.

**3.8 DEWATERING**

3.8.1 If the Contractor determines that dewatering is necessary to construct the work, the Contractor shall submit an overall plan for dewatering and any required diversion of water. Completely address in the plan installation and removal of the required systems and features. Dewater for construction, obtain and review all necessary information to ensure dewatering efforts are in compliance with regulations, and ensure the designed dewatering efforts are adequate based on-site conditions and climate and other variables that may affect dewatering efforts. Information provided by the Owner regarding dewatering requirements and site conditions shall in no way relieve the Contractor of full responsibility for all dewater planning, efforts, and costs. Ensure the Work will not be damaged by buoyant forces or by currents should water enter the excavation or during the removal of this water. Ensure dewatering efforts do not impact adjacent structures or property, result in instability of the excavation floor or slopes, produce unsafe working conditions, or damage to animals or the environment.

**3.9 BIOENGINEERED STRUCTURES**

3.9.1 Erosion Control Blanket:

3.9.1.1 Site Preparation: Grade and shape the area of installation. Apply fertilizer as needed prior to installation of the erosion control blankets. Make sure top layer soil is free of clods, rocks, wood and other obstructions so that the erosion control blanket is in direct contact with soil. Include a 12" deep and 12" wide initial anchor trench along the top side of the erosion control blanket as shown on the Contract Drawings.

3.9.1.2 Embed the top side of the erosion control blanket in the initial anchor trench as shown on the Contract Drawings. Then, unroll the erosion control blanket down slope. The blanket should not be stretched but should have full contact with the soil. Anchor blanket using staples or stakes as noted in "Anchoring" below.

3.9.1.3 Overlap edges of adjacent parallel rolls by approximately 6" and anchor with wood stakes at 30" spacing.

3.9.1.4 Where blankets have to be spliced, place upper blanket end over lower blanket end (shingle style) with 12" overlap and anchor with two staggered rows of wood stakes at 12" spacing.

3.9.1.5 Anchoring: Use wooden stakes (at least 6" long) to anchor the erosion control blanket to the ground. Keep a minimum edge distance of 2" from the edge of the erosion control blanket to the center of the stakes.

3.9.2 New BIOD Block Stabilization:

3.9.2.1 Before installing the coir block system, clean and level the base of the bank. Place at least 2 inches of soil on the top and level the surface well.

3.9.2.2 Place a coir block unit on level surface, keeping the female end towards direction of extending, and spread the bottom fabric. Anchor the bottom fabric to the ground well with suitable length metal staples or wooden pegs. Place 100% biodegradable coconut fiber erosion control blanket inside coir block. Fill soil up to the height of the coir block and compact the filled soil well. Cover the compacted filled material with coconut fiber erosion control blanket and top flap of coir block and anchor it well.

3.9.2.3 Repeat the coir block installation procedure described above to make soil lift layers as needed to the top of the bank. On the very top layer, spread grass seeds.

3.9.2.4 Where planting through the block is necessary, remove the blocks' coir plugs and insert the live plants through the holes into the middle of the soil layer.

3.9.2.5 To join blocks together, insert the male end of the second coir block to female end of first coir block and drive in stakes. Drive stakes through overlapping fabrics of two block units at their connection to avoid failures through the connection.

3.9.2.6 Use minimum 2 inch x 2 inch x 36 inch hardwood stakes every 3 feet to anchor the bottom fabric to the ground before filling with soil and 2 inch x 2 inch x 36 inch hardwood stakes on the top fabric after filling with soil. Use of additional anchors will increase the safety factor of the constructed slope.

**3.10 IRRIGATION**

3.10.1 Irrigation of the bioengineered features and structures shall be started immediately after installing erosion control products and vegetation. Water shall be applied to supplement rainfall at a sufficient rate to ensure moist soil conditions to a minimum 12-inch depth. Run-off and puddling shall be prevented. Watering trucks shall not be driven over turf areas, unless otherwise directed. Watering of other adjacent areas or plant material not related to work efforts shall be prevented. Water shall be applied to trenches immediately before placement of live vegetation. Water shall be placed on the completed bioengineered features and structures at the end of each day, as needed to control dust and to prevent drying of vegetation, and at the completion of the bioengineered features and structures.

NO.	REVISIONS DESCRIPTION	DATE		BY
		DATE	DATE	

**3.11 FIELD QUALITY CONTROL**

3.11.1 The work site will be inspected by the Engineer prior to final acceptance of work. A punch list noting deficiencies will be compiled by the Engineer and provided to the Contractor. Perform, repair, adjust, align, or otherwise comply with the specified work on the punch list to the satisfaction of the Engineer. Notify the Engineer at least 14 days prior to the inspection that work shall be ready for inspection. Work will not be accepted until all punch list items are resolved and all work meets or exceeds contract requirements. Final acceptance of work shall not be provided by the Contracting Officer until all defects or deficiencies are corrected. Final Acceptance shall occur only after all corrective actions and supplemental viable plantings are complete and the structure meets performance standards and all contract requirements. Comply with necessary repairs to the structure and vegetation as stated in the warranty.

**3.12 CLEAN-UP**

3.12.1 Excess material, debris, and waste materials shall be disposed of offsite at an approved landfill or recycling center. Adjacent paved areas shall be cleared. The site shall be restored to preexisting conditions to the extent reasonably possible and to the satisfaction of the Engineer.

**3.13 PROTECTION**

3.13.1 Immediately upon the start of the installation in an area, the area shall be protected against traffic or other use by erecting barricades and providing signage as required, or as directed by the Engineer or Owner. Protect the work site and vegetation from damage and vandalism and free of trash and debris until final acceptance by the Engineer.

**3.14 DOCUMENTATION**

3.14.1 The Contractor shall establish and provide the Owner with recommendations for bioengineering practices to record the desired information and to assure compliance with contract requirements, including, but not limited to, the following:

3.14.1.1 Maintenance Records: Recommend that the Owner visit, inspect, and document site conditions after the completion of construction every week for the first year and every two weeks thereafter until the end of the second year. The recommended documentation shall include written reports on site structure and vegetation conditions, damage, plant loss, and the like, to fully describe site conditions at the time of the visits and changes observed since previous visits. The recommended documentation shall include photographs of the site and areas of growth, defects, or damage to be included with the records.

**END OF SECTION**

**DIVISION 32 – EXTERIOR IMPROVEMENTS**

**SECTION 32 94 16 – LANDSCAPE TIMBERS**

**PART 1 – GENERAL**

**1.1 WORK INCLUDED**

1.1.1 The work of this section consists of:

- 1.1.1.1 Relocating and anchoring the existing driftwood over the New Sand Fill as shown on the Contract Drawings.
- 1.1.1.2 Installing new, supplemental large woody debris logs over the New Sand Fill, if authorized by the Owner.
- 1.1.1.3 Installation of anchoring systems for all driftwood and large woody debris logs.

1.1.2 The work of this section shall comply with all regulatory permits for the project

**1.2 RELATED SECTIONS**

- 1.2.1 Section 00 41 13 – Bid Form.
- 1.2.2 Section 01 33 01 – Additional Submittal Requirements
- 1.2.3 Section 01 60 00 – Special Contract Requirements
- 1.2.4 Section 31 10 00 – Site Clearing
- 1.2.5 Section 31 23 00 – Excavation, Grading, and Slope Preparation
- 1.2.6 Section 31 32 39 – Bioengineering Practices for Shoreline Stabilization

**1.3 MEASUREMENT AND PAYMENT**

- 1.3.1 Payment for the work required under this Technical Specifications Section shall be included with the related items of Work in Section 00 41 13, Bid Form or incidental to the Work.
- 1.3.2 Relocating and anchoring the existing driftwood will be paid at the contract Lump Price appearing on the Bid Form and will not be measured.
- 1.3.3 Installing new, supplemental large woody debris logs will be measured by the number of large woody debris logs installed and paid for at the contract unit price.

**1.4 SUBMITTALS**

1.4.1 General: Refer to Section 01 33 01, Additional Submittal Requirements for submittal requirements and procedures.

1.4.2 Samples:

1.4.2.1 Anchors, Cables, and Cable Clamps: Anchors, cables, and cable clamps shall be pre-approved by the Engineer prior to delivery to the work site. The Contractor shall submit the manufacturer's literature for the proposed anchors, cables, and cable clamps.

1.4.2.2 Supplemental Large Woody Debris Logs: Logs shall be pre-approved by the Engineer and Owner prior to importation to the work site. The Contractor shall submit five digital color photographs of the proposed logs to the Engineer and Owner ten (10) working days before delivery to the site. Pressure treated or otherwise chemically treated logs shall not be allowed under any circumstances. All photos shall include a person for scale.

1.4.3 Photographs: Submit photographs covering each piece of existing driftwood relocated and installed onsite.

1.4.4 Purchase Receipts: Submit purchase receipts with each supplemental large woody debris log, stating the type of material and quantity, with each Application for Payment that includes the work specified in this section.

**1.5 QUALITY CONTROL**

1.5.1 Follow all manufacturer recommendations during the installation of the anchor cables and cable clamps.

**1.6 SITE CONDITIONS**

1.6.1 Unfavorable Weather Conditions: Installation of the anchored driftwood shall not be performed during weather or wave conditions that might damage or be detrimental to the condition of existing ground, in-progress work, or completed work.

1.6.2 Prevention of Erosion: Comply with requirements specified in the regulatory permits and the following:

- 1.6.2.1 Prevent erosion of stockpiles, ditches, embankments, filled, backfilled, and graded areas until the anchored driftwood has been installed.
- 1.6.2.2 Perform "protective grading" to provide positive drainage and to minimize ponding of surface water.

**PART 2 – PRODUCTS**

**2.1 DRIFTWOOD**

2.1.1 The driftwood to be installed over the New Sand Fill shall be sourced from the existing driftwood that has been removed and set aside per Section 31 10 00, Site Clearing.

2.1.2 The driftwood to be installed shall not have weaknesses such as cracks and splits through more than 25 percent of the log diameter.

2.1.3 The allowed sizes of the driftwood to be relocated and anchored shall be the following:

- 2.1.3.1 Diameter: 6" minimum, 36" maximum
- 2.1.3.2 Length: 5' minimum; 32' maximum

**2.2 SUPPLEMENTAL LARGE WOODY DEBRIS LOGS**

2.2.1 Supplemental large woody debris logs shall be natural and untreated oak, maple, beech, eastern Cottonwood (*Populus deltoides*), ash (*Fraxinus americana*), or other Engineer-approved hardwood species and shall not be sourced from an area with documented occurrences of Sudden Oak Death.

2.2.2 Supplemental large woody debris logs shall not have weaknesses such as cracks and splits through more than 25 percent of the log diameter. Logs shall be of the following sizes:

- 2.2.2.1 Short logs: 12" ± 3" dia. by 10' ± 2' long
- 2.2.2.2 Long logs: 24" ± 6" dia. by 24' ± 4' long

**2.3 ANCHORING**

2.3.1 Anchors: Log anchors shall be earth anchors as shown on the Contract Drawings capable of providing at least 5000 lbs. holding capacity in loose fine sand, alluvium soft-firm clays, varied clays, fill, and fine-saturated silty sand.

2.3.2 Cables: Aircraft cable shall be plastic- or vinyl-coated, galvanized, and very flexible or be an Engineer-approved equivalent. It shall have a minimum diameter of 3/8-inch and a minimum breaking strength of 17,500 pounds.

**PART 3 – EXECUTION**

**3.1 STAKING AND GRADES**

3.1.1 Lay out the work, establish all necessary markers, benchmarks, grading stakes, and other stakes as required, in accordance with the requirements specified under Part 1 – General, "Layout of Work and Field Engineering" in Section 01 60 00, Special Contract Requirements.

**3.2 QUALITY CONTROL**

3.2.1 The Contractor is allowed to cut existing driftwood pieces that exceed the maximum dimensions listed in Part 2 – Products, Driftwood to bring larger pieces into the acceptable size ranges.

3.2.2 The remaining existing driftwood that does not conform to the size and quality requirements in Part 2 – Products, Driftwood above shall be removed from the

NO.	REVISIONS DESCRIPTION	DATE	BY



before release and capable of moving the stone if necessary. Dragline buckets and skips shall not be used for placement of stone. Casting or dropping of stone over two (2) feet or moving by drifting and manipulating down the slope shall not be permitted. Stone shall not be stockpiled on completed sections of a stone structure. Final finishing shall be done as the material is placed.

3.1.2 Toe Stone: Toe Stone shall be placed at the locations shown on the contract documents and shall be entrenched such that the bottom of the toe stone is at the elevation shown on the Contract Drawings or 2 feet below the existing grade, whichever is lower. Toe Stone shall be placed by mechanical means in a manner to produce a resultant mass of rock with the minimum practicable percentage of voids, and the maximum practicable interlocking and stone to stone contact. Rehandling of individual stones after initial placement may be required as necessary to achieve this result.

3.1.3 ODOT Type "A" Armor Stone: Armor stone shall be placed individually to produce a full layer thickness in one operation in a manner to avoid displacing or placing undue impact force on underlying material and to minimize chipping of stones. Stone shall be placed by mechanical means in a manner to produce a resultant mass of rock with the minimum practicable percentage of voids, and the maximum practicable interlocking and stone to stone contact. Rehandling of individual stones after initial placement may be required as necessary to achieve this result. Placement shall begin at the bottom of the slope with the placement of the toe stones and then proceed upward. Largest armor stone shall be placed as toe stones.

END OF SECTION

REVISIONS	NO.	DESCRIPTION	DATE	BY