

# Appendix A

**(Field Evaluation Manual for Ohio's  
Primary Headwater Habitat Streams)**

*State of Ohio*  
*Environmental Protection Agency*

**Division of Surface Water**

## **Field Evaluation Manual for Ohio's Primary Headwater Habitat Streams**



Creek chub



Stonefly  
larva



Two-lined salamander

**October 2009 (Version 2.3)**

Ted Strickland, Governor  
Lee Fisher, Lt. Governor  
Chris Korleski, Director

**THIS PAGE INTENTIONALLY LEFT BLANK**

## **Notices:**

**This document was developed by the Ohio Environmental Protection Agency (Ohio EPA) as a tool to provide standardized assessment methodologies for primary headwater habitat streams in Ohio. The manual presents methods that Ohio EPA has developed to better assess the actual and expected biological conditions in these waterways, and it outlines an acceptable methodology on how to classify primary headwater habitat streams. However, the manual does not represent an officially sanctioned policy or regulation of the Ohio EPA unless it is specifically referenced in rule. All statements regarding aquatic life use designations for primary headwater streams should be read with the understanding that new use designations require revisions to Ohio's water quality standards regulations (OAC Chapter 3745-1) through an administrative rule making process. Ohio EPA initiated a rule making process in August 2008 and these regulations may become effective in the near future.**

**All addresses for access to internet sites for sources of information referenced in this manual were accurate at the time that this manual was finalized. Over time it can be expected that these links may become outdated.**

**This manual revises prior documents made available to the public on standardized sampling in primary headwater streams (Davic, 1996; Anderson et al. 1999; Ohio EPA, 2002 a). Aspects of this manual may change as new information is made available. Should this document become referenced in rules within the water quality standards, any future revisions will be conducted in conjunction with future agency rule updates. Questions regarding Ohio EPA water quality standard regulations, and aquatic life use designations, should be directed to the Division of Surface Water, PO Box 1049, Columbus Oh 3216-1049 (614-644-2876).**

## **Acknowledgments:**

This 2009 revision of the manual was edited by Paul Anderson, Division of Surface Water, Northeast District Office, 2110 East Aurora Road, Twinsburg, Ohio 44087. Technical questions regarding this manual should be directed to him at: (330) 963-1228 or via e-mail: [paul.anderson@epa.state.oh.us](mailto:paul.anderson@epa.state.oh.us). Primary investigators for the Ohio EPA primary headwater stream assessment program are Paul Anderson, Mike Bolton, Robert Davic, and Steve Tuckerman; under the direction of project coordinators Dan Dudley, Bill Schumacher, and Chris Skalski. Other members of the Ohio EPA Headwater Habitat Work-Group whom contributed technical review and/or field data were: Jim Grow, MaryAnne Mahr, Louise Snyder, Ric Queen, Ed Rankin, Hugh Trimble, Greg Orr, and Chris Yoder. We acknowledge the significant efforts of numerous Ohio EPA summer interns as well as Matt Scharver and Chad Edgar of the Lake County Soil and Water Conservation District for their contribution in the collection of data. We also thank members of the Ohio Academic Panel that was convened by Dr. Gene Willeke of Miami University (Ohio) for their valuable technical comments on sampling procedures found in the original version of this manual.

**Conversions:**

Throughout this manual various metric and English measurement units are cited due to different protocols established in the engineering and basic sciences. Some useful conversions are given below:

<b>To covert</b>	<b>into</b>	<b>Multiply by, or use formula</b>
Square mile	hectare	259
Square mile	square kilometer	2.590
Feet	meters	0.3048
Inches	centimeters	2.540
Miles	kilometers	1,609
Hectares	acres	2.471
Celsius	Fahrenheit	$(1.8 * ^\circ\text{C}) + 32$
Fahrenheit	Celsius	$5/9 * (^\circ\text{F} - 32)$

**List of Acronyms:**

7Q10	Minimum seven-day average flow with a ten-year recurrence interval (see USGS, 2001 for Ohio data).
CWA	Clean Water Act (Public Law 92-500, October 18, 1972)
CWH	Coldwater Habitat (OAC Chapter 3545-1)
EPT Taxa	Benthic macroinvertebrates from the Ephemeroptera, Plecoptera, and Trichoptera (mayflies, stoneflies, and caddisflies)
EWH	Exceptional Warmwater Habitat (OAC Chapter 3745-1)
GIS	Geographic Information System
GPS	Geographic Positioning System
HHEI	Headwater Habitat Evaluation Index
HMFEI	Headwater Macroinvertebrate Field Evaluation Index
IBI	Index of Biotic Integrity
ICI	Invertebrate Community Index
MWH	Modified Warmwater Habitat (OAC Chapter 3745-1)
NPDES	National Pollutant Discharge Elimination System
NRCS	Natural Resources Conservation Service (formerly SCS)
OAC	Ohio Administrative Code (state administrative rules)
Ohio EPA	State of Ohio Environmental Protection Agency
ODNR	State of Ohio Department of Natural Resources
ORC	Ohio Revised Code (state law)
PHWH	Primary Headwater Habitat
QHEI	Qualitative Habitat Evaluation Index
SCS	Soil Conservation Service (now NRCS)
USEPA	United States Environmental Protection Agency
USGS	United States Geologic Survey
WWH	Warmwater Habitat (OAC Chapter 3745-1)

## **Preface to Version 1.0 (Ohio EPA, 2002):**

The Federal Clean Water Act provides for "maintaining the biological integrity of the nation's waters", from the mouths to the headwaters. In carrying out the regulatory responsibilities for streams in the State of Ohio, there is a need for a methodology that deals with proposed activities in the extreme headwaters areas, what Ohio EPA calls "primary headwater habitat" (PHWH) streams. It is well established in the scientific literature that headwater streams of the kind addressed in this manual are important to the quality of water and biological communities in larger streams to which these primary headwater streams are tributary.

The primary headwater streams addressed in this manual are quite small, less than 1.0 mi<sup>2</sup> drainage area. Many of them would not show up as blue lines on USGS 1:24,000 quadrangle maps, although almost all of them would be visible and marked on county soil maps. These streams are not often defined or assigned beneficial uses in Ohio water quality standards. The sampling methods, and concurrent biological and habitat indices now used by OEPA to classify waterways for existing water quality (e.g., IBI, ICI, QHEI) are oriented toward larger streams. Because these "index of biotic integrity" assessment systems are watershed size dependent, they often cannot be used to identify the well being of the native fauna that survive and reproduce in small headwater stream ecosystems.

In the absence of comparable measures of stream quality for extreme headwaters, government agencies responsible for protection of water resource integrity may appear to be arbitrary if they seek to approve or deny a permit or certification application to lower water quality in primary headwater streams. The stream classification methodology presented in this manual helps to fill that void, in a manner similar to the Ohio EPA (ORAM) sampling methods now being used to classify jurisdictional wetlands. This primary headwater stream manual outlines a predictable three-tiered protocol that can be used to conduct rapid assessment of headwater stream quality. The lowest level of field effort is a relatively rapid habitat evaluation procedure known as the "Headwater Habitat Evaluation Index" (HHEI). It is based on three physical measurements that have been found to correlate well with biological measures of stream quality. Two levels of biological assessment, one at a order-family level of taxonomic identification, the second to genus-species, provide flexibility in reaching a final decision on the appropriate aquatic life use designation needed to protect the native fauna of any primary headwater stream.

The great number of primary headwater streams in Ohio, their diverse ecological functions, and their value to the well being of the larger rivers, lakes, and wetlands to which they are tributary underscores the importance of their proper classification and protection.

Gene E. Willeke, Ph.D., P.E.  
Director, Institute of Environmental Sciences  
Miami University  
Oxford, Ohio

## Table of Contents

Notices .....	ii
Acknowledgements .....	ii
Conversions .....	iii
List of Acronyms .....	iv
Preface to Version 1.0 (Ohio EPA, 2002) .....	v
Table of Contents .....	vi
List of Figures .....	viii
List of Tables .....	ix
List of Attachments .....	ix
A Quick Guide to the PHWH Assessment Process .....	x
<a href="#">1.0</a> Introduction and Rationale .....	1
<a href="#">2.0</a> Desktop Evaluation and Background Information .....	9
<a href="#">2.1</a> Mapping Resources .....	9
<a href="#">2.2</a> When to Sample .....	10
<a href="#">2.3</a> Equipment Checklist .....	11
<a href="#">2.4</a> Reference Materials .....	11
<a href="#">3.0</a> Stream Reach Delineation and Site Selection .....	12
<a href="#">3.1</a> PHWH Streams and Stream Reaches .....	12
<a href="#">3.2</a> Site Selection .....	14
<a href="#">3.3</a> QHEI vs. HHEI Evaluation in Headwater Streams .....	15
<a href="#">4.0</a> Rheocrene Habitats and Seepage Areas .....	15
<a href="#">5.0</a> Primary Headwater Habitat (PHWH) Stream Evaluation .....	16
<a href="#">5.1</a> General Stream Information .....	17
<a href="#">5.2</a> Channel Modification Category Determination .....	19
<a href="#">5.3</a> Calculation of the Headwater Habitat Evaluation Index (HHEI) .....	21
<a href="#">5.3.1</a> Metric #1: Stream Channel Substrate .....	21
<a href="#">5.3.2</a> Metric #2: Maximum Pool Depth .....	27
<a href="#">5.3.3</a> Metric #3: Average Bankfull Width .....	28



## Table of Contents (cont.)

<a href="#">5.3.4</a>	Total HHEI Score .....	33
<a href="#">5.4</a>	Using the HHEI Assessment to Assign Existing Aquatic Life Use Potential .....	33
<a href="#">5.5</a>	Riparian Zone and Flood Plain Quality .....	34
<a href="#">5.6</a>	Flow Regime .....	36
<a href="#">5.7</a>	Sinuosity .....	37
<a href="#">5.8</a>	Stream Gradient .....	38
<a href="#">5.9</a>	PHWH Form – Page 2 .....	39
<a href="#">5.9.1</a>	QHEI Assessment .....	39
<a href="#">5.9.2</a>	Downstream Designated Use(s) .....	39
<a href="#">5.9.3</a>	Location Information .....	39
<a href="#">5.9.4</a>	Miscellaneous .....	39
<a href="#">5.9.5</a>	Biological Evaluation Summary .....	41
<a href="#">5.9.6</a>	Drawing and PHWH Stream Reach Narrative Description .....	41
<a href="#">6.0</a>	Biological Sampling .....	42
<a href="#">6.1</a>	Headwater Fish .....	42
<a href="#">6.2</a>	Headwater Salamanders .....	44
<a href="#">6.2.1</a>	Salamander Sampling Effort .....	47
<a href="#">6.2.2</a>	Salamanders Voucher Specimens .....	49
<a href="#">6.3</a>	Headwater Benthic Macroinvertebrates .....	53
<a href="#">6.3.1</a>	Headwater Macroinvertebrate Field Evaluation Index (HMF EI) .....	53
<a href="#">6.3.2</a>	Using the HMF EI to Assign Aquatic Life Use Designations to a PHWH Stream .....	54
<a href="#">7.0</a>	Using a Biological Assessment to Assign an Aquatic Life Use Designation .....	57
<a href="#">8.0</a>	Summary of Steps to Assign an Aquatic Life Use Designation to a PHWH Stream .....	58
<a href="#">9.0</a>	Recommended Levels of Protection for PHWH Stream Classes .....	59
<a href="#">10.0</a>	References .....	60

## List of Figures

Figure 1. The river continuum concept and its relationship to biological communities found in primary headwater habitat streams. ....	1
Figure 2. Ohio EPA PHWH sampling locations 1999-2001. ....	2
Figure 3. Conceptual water pathways in different types of PHWH streams. ....	8
Figure 4. Representative NRCS (aka SCS) County Soil Map showing location of Primary Headwater Habitat (PHWH) streams in a local watershed. ....	9
Figure 5. Hypothetical relationship of the primary headwater stream reach concept, showing 200 ft (61 m) upper and lower reach boundaries (dark rectangles).....	13
Figure 6. Example watershed delineation from the Ohio STREAMSTATS web page. <a href="http://water.usgs.gov/osw/streamstats/ohio.html">http://water.usgs.gov/osw/streamstats/ohio.html</a> .....	18
Figure 7. Example of basin data provided from the Ohio STREAMSTATS web page following watershed delineation.....	19
Figure 8. An example of a completed Substrate Metric section from page 1 of the PHWH Form.	23
Figure 9. A stylized representation of a substrate particle indicating the proper way to determine the size category for classification.....	24
Figure 10. Schematic representation of the relationship of bankfull and floodprone stream widths. ....	30
Figure 11. Measuring bankfull width in an incised PHWH stream. ....	31
Figure 12. Bankfull indicators noted for a Class II PHWH stream from Fulton County, Ohio. ....	31
Figure 13. Bankfull indicators noted for a Class III PHWH stream from Hocking County, Ohio. ....	32
Figure 14. A line level. ....	32
Figure 15. PHWH classification flow chart based on HHEI scoring.....	35
Figure 16. Diagram indicating the method for determining sinuosity as recorded on the PHWH form. ....	37

### List of Tables

<a href="#">Table 1.</a>	Summary of estimated miles of flowing waterways in Ohio .....	5
<a href="#">Table 2.</a>	Suggested terminology to identify different types of hydrology associated with biological communities and stream classes in primary headwater streams in Ohio .	7
<a href="#">Table 3.</a>	Guidelines for the determination of the stream channel modification category for the HHEI form .....	20
<a href="#">Table 4.</a>	Fish species observed/collected in Primary Headwater Habitat streams in Ohio, 1999-2000. Fish were captured in 67 of the streams sampled .....	43
<a href="#">Table 5.</a>	Species of salamanders that can be used as bio-indicators of Class III (cool-cold water, perennial flow) and Class II (warmwater, intermittent flow) PHWH streams in Ohio .....	45
<a href="#">Table 6.</a>	List of salamander species in Ohio that use primary headwater stream corridors as a habitat for egg deposition (oviposition) and larval growth .....	50
<a href="#">Table 7.</a>	Headwater Macroinvertebrate Field Evaluation Index (HMF EI) scoring categories for use in assessing primary headwater habitat streams in Ohio .....	56

### List of Attachments

<a href="#">Attachment 1.</a>	The Ohio Primary headwater Habitat Evaluation Form (PHWH Form)
<a href="#">Attachment 2.</a>	Field Check List for Primary Headwater Stream Sampling
<a href="#">Attachment 3.</a>	Ohio EPA Cold and Cool Water Macroinvertebrate Taxa List
<a href="#">Attachment 4.</a>	Substrate Pebble Count Data Sheet
<a href="#">Attachment 5.</a>	Headwater Stream Salamander Voucher Sheet

## **A Quick Guide to the PHWH Assessment Process**

The following sequence of tasks presents a generalized summary of the various steps involved in a PHWH stream assessment.

### **Desktop Evaluation (Section 2.0)**

- Step 1** Obtain the NRCS county soil map and USGS 7.5 min. topographic map for the watershed area under investigation. ([Section 2.1](#))
- Step 2** Delineate the property boundary on the NRCS soil map. Determine total linear feet (or meters) of all potential PHWH streams.
- Step 3** Determine the total watershed area for PHWH streams at the most downstream location of the property boundary using the USGS STREAMSTATS web page, the USGS topographic map, the NRCS soil map, or other mapping tools at the appropriate scale. ([Section 5.1](#))
- Step 4** Prepare to conduct an on-site PHWH stream evaluation if the watershed area is less than 1 mi<sup>2</sup> (259 ha). Prepare to conduct a QHEI/WWH stream evaluation if the watershed area is greater than 1 mi<sup>2</sup> (259 ha).

Note: Where determined to be appropriate by a qualified biologist, a PHWH evaluation can be conducted in streams with watershed areas greater than 1 mi<sup>2</sup> (259 ha), or a QHEI/WWH evaluation can be conducted in streams with watershed areas less than 1 mi<sup>2</sup> (259 ha).

### **Field Reconnaissance and Sampling**

- Step 5** Determine if the streams in question are at base flow for the period of the year that the survey is being conducted. In addition determine whether or not stream flows in the vicinity of the study area are above 7Q10 using USGS stream flow information. If **no**, do not proceed with evaluation. If **yes**, proceed with the assessment. If stream flows in the vicinity of the study area are less than 7Q10 flow, use attainability analyses should not be conducted. (see [Section 2.2](#))
- Step 6** Delineate (with flags) 200 ft (60m) stream reach sections for each mainstem PHWH stream. Begin stream reach delineation starting at the most downstream property boundary, and continue in an upstream direction. Tributaries of the mainstem with channel lengths greater than 200 ft (60 m) should be evaluated as separate PHWH streams. Very small seepage areas can be assessed as being part of the associated 200 ft (60 m) PHWH stream reach. ([Section 3.0](#))
- Step 7** Record observational data on the PHWH Form (Attachment 1) regarding the physical nature of the stream corridor including the stream flow condition observed, riparian zone land use and buffer width, channel modification category, etc. Take photographs and index them for later association with the appropriate data sheet. ([Section 5.0](#))
- Step 8** If appropriate, conduct water chemistry sampling before walking in the stream water and adding turbidity. ([Section 5.9.4](#))

- Step 9** If conducting a biological survey, **begin by sampling for amphibians** (salamanders), then fish, and finally benthic macroinvertebrates. Collect voucher specimens. The sequence of sampling from vertebrates to invertebrates is important because water with low turbidity is very important to accurately conduct a visual search for aquatic salamander larvae. However, it is also important that clear water be present when conducting the fish and invertebrate surveys. Thus you must wait until the water is clear to conduct these surveys. Record all biological data on pages 3 and 4 of the PWH Form. ([Section 6.0](#))
- Step 10** **Complete the HHEI assessment for all sites.** Measure the bankfull width, maximum pool depth, and substrate composition as directed in this manual. Record all data on pages 1 and 2 of the [PWH Form](#). Be sure to complete the entire PWH Form in Attachment 1. ([Section 5.3](#))
- Step 11** Optional habitat measures for parameters such as gradient (surveyed), flood prone width, and quantitative pebble counts may now be conducted if deemed necessary. ([Section 5.3.1](#), [Attachment 4](#))

### **Final Report**

- Step 12** Use data from the HHEI evaluation ([Attachment 1](#)) **and** the results of the biological survey (if conducted) to determine the appropriate PWH class (Class I, II, III). Use the decision making flowchart in [Figure 15](#) when using the HHEI information in the absence of a biological survey. Use the guidelines from [Section 7.0](#) of this manual when using biological data to classify the stream reach. See also the summary of steps in [Section 8.0](#) for guidance on how to reach a final decision on appropriate PWH classification.

Results from the biological survey will take precedence over results from a HHEI survey unless there is reason to believe that chemical stressors are present which could limit the presence of biological communities (i.e., warm water resulting from the lack of riparian cover, toxic levels of heavy metals, elevated ammonia-N, low dissolved oxygen, low pH, excessive stream bed siltation, etc). Where chemical stressors are shown to be present, the results from the HHEI survey can be used to identify the *potential* PWH stream class.

Summarize the results of the field evaluation and write a report with recommended PWH stream classes for the streams investigated.

## 1.0 INTRODUCTION and RATIONALE

This document revises Version 1.0 of the field evaluation manual for primary headwater habitat (PHWH) streams (Ohio EPA, 2002 a). The instructions and modifications of methods in this revision supersede the previous version of the manual.

The methods in this manual are calibrated to assessment of a primary headwater habitat stream (PHWH stream). **A primary headwater habitat stream is a surface water of the state, as defined in Ohio Administrative Code 3745-1-02, having a defined bed and bank, with either continuous or periodical flowing water, with watershed area less than or equal to 1.0 mi<sup>2</sup> (259 ha), and maximum pool depths equal to or less than 40 cm (15.7 in.).**

Primary headwater streams are the very smallest swales and streams that are the origin of larger water bodies in the state. The chemical, physical, and biological quality in larger streams and lakes are closely connected to the overall health of headwater streams and their watersheds (Alexander et al., 2007; Meyer et al., 2007; Peterson et al., 2001; Wipfli, 2005). Primary headwater streams provide important economic and ecological functions through the retention of sediment, water, and organic matter; nutrient reduction; and by providing corridors for wildlife dispersal (Ohio EPA, 2003; Meyer and Wallace, 2001; Peterson et al., 2001). They may harbor a unique native fauna of temperature sensitive vertebrates (fish and/or amphibians), benthic macroinvertebrates, and aquatic plants where flows are permanent. These streams are a natural extension of the stream continuum concept (Figure 1), which identifies how larger streams in a watershed are dependent on chemical and biological processes that occur in the smaller streams that flow into them.

Some think of small streams and ditches as nuisances or merely storm water conveyances, and the concept that cumulatively these waters can have substantial consequences on downstream water quality is not well known to the general public.

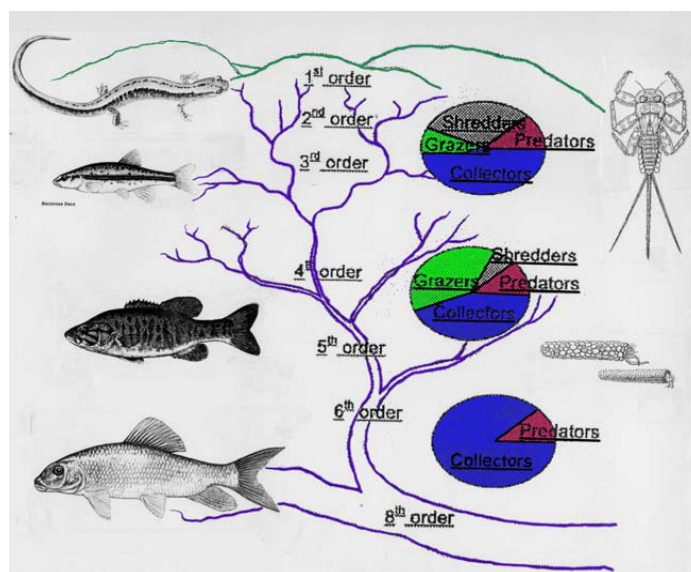
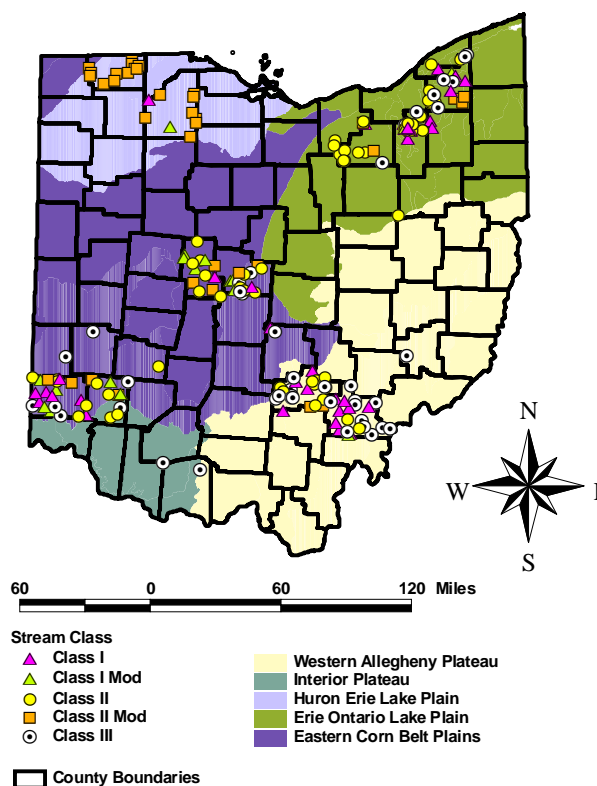

Figure 1. The river continuum concept and its relationship to biological communities found in primary headwater habitat streams (after Vannote et al., 1980).

The primary objective of the federal Clean Water Act (CWA, Sec. 101 a) is “to... restore and maintain the chemical, physical, and biological integrity of the nation's waters”, a goal that clearly applies not only to large rivers but also to the smaller headwater streams of the nation's watersheds. In Ohio primary headwater streams that connect to other flowing waters are defined as “waters of state” in the Ohio Revised Code (ORC 6111.01). Discharges from point sources into small streams and drainage channels are regulated by National Pollutant Discharge Elimination System (NPDES) permits as discharges to waters of the state.

In Ohio, water quality standards contain both chemical and biological components (OAC Chapter 3745-1). Current biological criteria (Index of Biotic Integrity or IBI for fish and the Invertebrate Community Index or ICI for macroinvertebrates) and sampling methods that apply to larger streams are not appropriate for many primary headwater streams given their small size and lack of deep pools. In addition, the relationship between hydrology, geomorphology, and biotic potential of primary headwater streams in Ohio is not completely understood.

Recognizing these limitations, from 1999 to 2001 the Ohio EPA conducted a statewide biological, chemical, and physical habitat evaluation of PHWH streams located within four of the major ecoregions of Ohio (Figure 2). This evaluation was a continuation of a primary headwater stream assessment initiative that has been made available to the public by Ohio EPA over the past decade (Davic, 1996; Anderson, et al, 1999; Ohio EPA, 2002a).



Fifty-nine PHWH streams were surveyed in 1999 with an additional 215 streams randomly sampled in 2000 from 5 rapidly developing areas in 10 Ohio counties. In 2001, 18 streams were sampled for seasonal trends (benthic macroinvertebrates), and additional data were collected from select counties. Detailed information on the results of these surveys is available in separate technical reports (Ohio EPA, 2002b; Ohio EPA, 2002c; Ohio EPA, 2002d).

**Figure 2. Ohio EPA PHWH sampling locations 1999-2001.**

In general, the results of this monitoring program indicate that two fundamental types of biological communities are present in the primary headwaters of Ohio:

1. Streams found to have native fauna adapted to cool-cold perennial flowing water characterized by a community of vertebrates (either cold water adapted species of headwater fish and/or obligate aquatic species of salamanders from the lungless family Plethodontidae), and/or a diverse community of benthic macroinvertebrates including cold water taxa, with larval life stages resident in the stream continuously on an annual basis. This type of PHWH stream is herein referred to as a **Class III-PHWH stream**.
2. Streams found to have a moderately diverse community of warm-water adapted native fauna either present seasonally or on an annual basis. The native fauna of these streams is characterized by species of vertebrates (fish or salamanders) and/or benthic macroinvertebrates that are pioneering, headwater, temporary, and/or temperature facultative. This type of PHWH stream is herein referred to as a **Class II PHWH stream**.
3. Primary headwater streams that are normally ephemeral, with water present for short periods of time due to infiltration from snow melt or rainwater runoff. Primary headwater stream channels observed to be normally dry, with little or no aquatic life present are herein referred to as **Class I-PHWH streams**.

**THE THREE TYPES OF PRIMARY HEADWATER STREAMS IN OHIO:**

1. **Class III-PHWH Stream (cool-cold water adapted native fauna)**
2. **Class II-PHWH Stream (warm water adapted native fauna)**
3. **Class I- PHWH Stream (ephemeral stream, normally dry channel)**

The primary physical habitat distinction between a Class I and Class II-PHWH stream is the presence of flowing water or isolated pools for extended periods of time in Class II-PHWH stream channels during summer months. The primary biological distinction is that Class I-PHWH streams either have no species of aquatic life present, or if present, the biological community is of relatively poor diversity.

In conjunction with the biological sampling conducted from 1999 to 2001, multiple measurements of numerous physical habitat variables were made at 274 PHWH stream locations following field methods in Anderson, et al. (1999). The purpose of this



sampling was to determine the feasibility of using a rapid assessment of physical habitat variables to predict, with a high degree of statistical confidence, the biological characteristics of a primary headwater stream. Using methodologies similar to those employed to develop the Qualitative Habitat Evaluation Index (Rankin, 1989), a Headwater Habitat Evaluation Index (HHEI), was constructed. The HHEI can be used to score physical habitat features that have been found to be statistically important determinants of biological community structure in PHWH streams with drainage area less than 1 mi<sup>2</sup> (259 ha).

The HHEI assessment is similar to, but different from, the "Habitat Suitability Index" approach used by the U.S. Fish and Wildlife Service to predict ecological habitat requirements for specific wildlife species (U.S. Fish and Wildlife Service, 1981). The Habitat Suitability Index (HSI) uses measures of habitat variables to predict life history characteristics of individual species of wildlife. In contrast, the primary design objective of the HHEI approach is to use measures of habitat variables to predict the presence or absence of an assemblage of cold-cool water adapted vertebrates (fish and/or lungless salamanders) and benthic macroinvertebrates (Class III biology). The secondary objective was to determine scoring parameters for use in predicting Class II and Class I biological communities.

Statistical analysis of a large number of physical habitat measurements showed that three habitat variables (channel substrate composition, bankfull width, and maximum pool depth) are sufficient to statistically distinguish Class I, II, and III-PHWH streams using the HHEI. Assigning positive and negative weighted scores to these three habitat variables results in the formation of a final composite HHEI score. The HHEI rapid assessment tool is most predictive when "modified" channels (e.g., channels modified by relocation, channelization, dredging) are separated from "natural" channels that have little or no evidence of channel modification. Thus indirectly, the final HHEI scoring process incorporates many more aspects of the geomorphology and hydrology of small stream channels (i.e., entrenchment, degree of sinuosity, etc.) than the limited set of three variables that require quantitative measurement.

The headwater stream network of watersheds is complex, and the proportion of the three primary headwater stream classes varies among ecoregions in Ohio (OSU, 2001). The average stream miles of the different types of streams estimated in Ohio are shown in Table 1. Some waterways without a defined stream bed and bank (non-stream waterways), constituting 18.4% of the total primary headwater drainage network in Ohio, fall outside the concept of a headwater "stream". These statistics were derived from data collected by Ohio EPA in 2001 using a random survey of primary headwater streams in various ecoregions. Manmade roadside ditches that are not a continuation of a natural stream channel are also included in the non-stream waterway designation.

**Table 1.** Summary of estimated miles of flowing waterways in Ohio. Statistics from OSU (2001).

Waterway Type	Length in Miles	Percent of Total
<b>Named Streams</b>		
(ODNR, USGS blue lines)	21,048	12.61%
<b>Unnamed Streams*</b>		
Class I- PHWH	36,405	21.80%
Class II-PHWH	51,250	30.69%
Class III-PHWH	27,551	16.51%
<b>Unnamed Waterways</b>		
Non-stream waterways <sup>#</sup>	30,708	18.39%
Total of all types: mean	166,962	100 (rounded)
95% Upper CI of mean	250,636	

\*A random site selection statistical approach was used to estimate the total length of "unnamed stream" miles. This value would include intermittent blue lines on USGS topographic 7.5 min. series maps.

<sup>#</sup>Non-stream waterways do not have a well defined bed-bank, thus they do not meet the concept of a "primary headwater stream". However, these waters do meet the definition of "waters of the state" in Ohio Revised Code, Section 6111.

The type of biological community found in primary headwater streams can shift abruptly from one PHWH stream class to another, such as when cold spring-fed groundwater flow intercepts a dry stream channel (e.g., Class I stream becomes a Class III). Other changes in species composition are gradual (e.g., when a cold Class III stream is sequentially diluted by contributions of warmer surface runoff or when incident sunlight warms the stream where shading is reduced). Yet other primary headwater streams maintain the same type of biological community throughout their length. Terminology that relates hydrology to the different classes of PHWH streams is provided in Table 2, and Figure 3.

A number of PHWH streams in Ohio are channelized, often with significant removal of riparian vegetation. Channelization leads to changes in stream hydrology, physical habitat degradation, and sedimentation problems that are recognized as the leading causes of impairment of Ohio's surface waters (Ohio EPA, 2008 a). Channelization or other forms of drainage improvement are often essential for agricultural production, especially in western and central Ohio. When drainage improvement projects place fill material into streams or wetlands a federal permit (CWA Section 404) and state water quality certification (CWA Section 401) are required.

Many different hydrological terms relate to the three classes of PHWH streams described in this manual. Terms such as perennial, permanent, continuous, intermittent, temporary, interrupted, and ephemeral are routinely used to describe the type of flow present in stream channels. The relationship between hydrology and potential PHWH stream class is summarized in the box below (see also [Figure 3](#) and [Table 2](#)). For

example, a perennial flowing PHWH stream may have either Class III (cool-cold water) or Class II (warm water) type of biology present, with the primary difference being water temperature, not flow regime.

<b>Perennial flow (continuous, permanent)</b>	<b>= either Class III or Class II PHWH stream</b>
<b>Interstitial flow (interrupted)</b>	<b>= either Class III or Class II</b>
<b>Intermittent flow (temporary, summer-dry)</b>	<b>= Class II</b>
<b>Ephemeral flow</b>	<b>= Class I</b>

The methods in this manual are based upon measurement of biological, chemical, and physical (HHEI) habitat characteristics that can be used to assign the appropriate classification for a primary headwater stream. A PHWH assessment should only be conducted after it has been determined that the stream under investigation has no possibility of supporting a well balanced fish community as measured by the fish-IBI due to its size and that other potential aquatic life use designations as found in OAC Chapter 3745-1 are not appropriate (i.e, Warmwater Habitat-WWH; Exceptional Warmwater Habitat-EWH; or Coldwater Habitat-CWH). As a rule of thumb, any stream with a watershed area greater than 1.0 mi<sup>2</sup> (259 ha), or with pools having a maximum depth over 40 cm, should first be evaluated using the QHEI and biological sampling methods appropriate for WWH, EWH, CWH, or MWH, aquatic life use designations (Ohio EPA, 1989; Rankin, 1989; Rankin, 1995; Ohio EPA, 2006 a).

All field observations and physical and biological data collected during the assessment are to be recorded on the Ohio EPA Primary Headwater Habitat Stream Evaluation (PHWH) form included as Attachment 1 of this manual. An overview of the sequence of tasks involved in a PHWH stream evaluation is found in the "Quick Guide to the PHWH Assessment Process" located in the front of this manual. Field personnel conducting these assessments should obtain permission from property owners to gain access to the streams, and any necessary local, State or Federal permits for conducting biological collections prior to conducting the assessment.

**Table 2.** Suggested terminology to identify different types of hydrology associated with biological communities and stream classes in primary headwater streams in Ohio. See also [Figure 3](#).

---

---

**“Continuous flow”**. Water that flows permanently in a stream channel. Also referred to as **“perennial”** or **“permanent”** flow. There are two general types of continuous flowing primary headwater streams:

1. **“Suprafacial flow”**<sup>\*\*</sup>. Streams with continuous flow on the surface of the stream bed substrate. Streams with suprafacial flow maintain surface flowing water at most times of the year (except for years of extreme drought) due to constant infiltration of surface runoff and/or groundwater recharge from subsurface aquifers. These streams may have Class II PHWH biology (if warm in summer) or Class III PHWH biology (if cold-cool in summer).
2. **Interstitial flow**<sup>\*</sup>. Streams with continuous flow that occurs seasonally under the surface of the stream bed within the interstitial spaces of coarse substrate, or cracks in bedrock. Also called **“interrupted flow”**. Streams with interstitial flow have visually dry stream beds with isolated pools of water that are hydraulically connected by slowly moving water. At times of sustained drought, this type of stream may only have water flowing within the subsurface alluvium. The perennial flow is maintained by either deep groundwater recharge from the water table, or from surface wetlands. These streams can maintain either a Class II (if warm in summer) or Class III type biology (if cold-cool in summer) in isolated pools of water, or in the interstitial spaces of the subsurface hyporheic zone, depending on the origin of the flowing water. The biology in warm water interstitial streams tends toward the intermittent stream type during sustained drought.

**“Periodical flow”**. Water that stops flowing along the stream channel during periods of no precipitation and/or groundwater recharge. There are two general types of periodical flow:

- (a) **“Intermittent flow”**. Also called **“temporary flow”**, or **“summer-dry”** type of stream. These streams have flow for extended periods of time seasonally, but gradually reach a state where there are either isolated pools of water that are not hydraulically connected by sub-surface flow, or a dry channel. Biology may be present in wet hyporheic subsurface substrate. Usually have a warm water Class II type of biology present from roughly October to June.
- (b) **“Ephemeral flow”**. These streams are normally dry and only flow during and after precipitation runoff (episodic flow). These streams normally have a dry stream channel with no evidence of isolated pools of water. May have Class I type biology present seasonally in the spring.

---

---

<sup>\*\*</sup> Note: The roots of the term “suprafacial flow” are: **supra**=above or surface; and **facial**=on the face of.

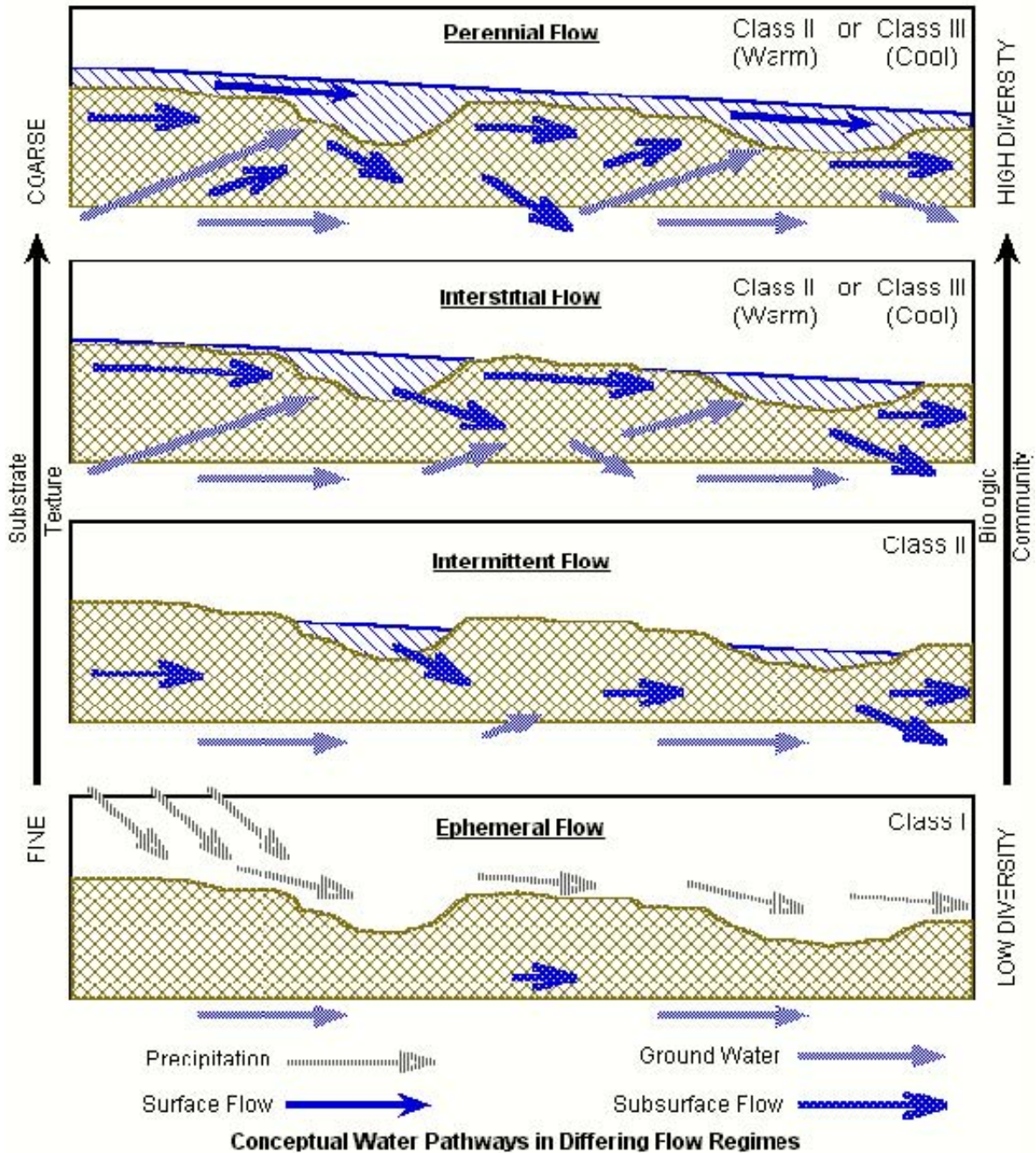
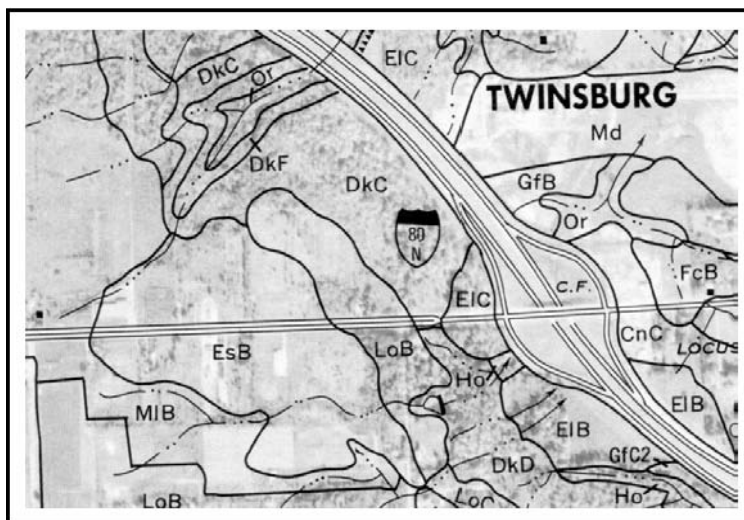

Figure 3. Conceptual water pathways in different types of PHWH streams.

## 2.0 Desktop Evaluation and Background Information

### 2.1 Mapping Resources

The potential location of a PHWH stream in the landscape can be identified using the USDA, National Resources Conservation Service (previous SCS) soil survey maps that are available for each of the 88 counties in Ohio (Figure 4). Different terminology is used in the various county soil surveys to identify potential PHWH streams. Terms such as drainage, stream-perennial, stream-intermittent, stream-unclassified, ditches, springs, drainage end, alluvial fan, etc. are used to identify small watercourses on these county soil maps. Each of these watercourses that connect to downstream surface waters of the state is a potential PHWH stream. County soil survey maps can be obtained at the following URL: [http://soils.usda.gov/survey/online\\_surveys/ohio/](http://soils.usda.gov/survey/online_surveys/ohio/) using the internet. Copies of the maps can also be obtained at county Soil and Water Conservation District (SWCD) offices and at many local and university libraries. All counties in Ohio now have digitized soil maps available for Geographic Information System (GIS) interfaces. However, these resources may be of limited use statewide since many counties have not digitized the hydrologic drainage information along with the soils distribution information. A directory of contact information for Ohio SWCD's can be found on the ODNR Division of Soil and Water Conservation web page: <http://ohiodnr.com/tabid/9093/Default.aspx>.



**Figure 4.** Representative NRCS (aka SCS) County Soil Map showing location of Primary Headwater Habitat (PHWH) streams in a local watershed. First order PHWH streams are those primary streams at the uppermost limits of the drainage network. Two first order PHWH streams merge to form a second order stream and so on until the drainage empties into a larger stream that has a specific designated use. Streams in Ohio with assigned designated uses are found in OAC, Chapter 3745-1. Total area shown in this figure is about 0.63 mi<sup>2</sup> (163 ha).

The NRCS mapping scale represents the most detailed knowledge of the distribution and abundance of potential primary headwater streams in Ohio. A common soil mapping scale is 1:15,840, but others do exist. Because the field and aerial survey data shown on many county soil survey maps were collected prior to 1970, a field assessment of a property may show that a potential PHWH stream has been relocated or placed in a drainage culvert. In some rare cases, a PHWH stream observed to be present during a site visit will not be shown on a county soil map, but may be shown on a U.S. Geologic Survey (USGS) topographic map. Thus both NRCS and USGS maps should be consulted to determine if any PHWH streams are potentially present.

Many Ohio counties have also developed other mapping resources such as high resolution aerial photography, small scale topographic maps (including maps of "derived" streams determined using topography), and drainage mapping resources in GIS formats that are readily available. In addition, as discussed in Section 2.5.1 of this manual, the USGS, in cooperation with other agencies has developed a web-based tool called STREAMSTATS that provides excellent capabilities for delineating stream reaches and watershed boundaries <http://streamstats.usgs.gov/ohstreamstats/>. In many areas of Ohio, the resolution of this tool is sufficient to capture the majority of the PHWH stream scale. The user is encouraged to utilize all desktop resources available within a particular locale to identify the presence of potential PHWH streams prior to conducting field surveys.

## 2.2 When to Sample

A biological or HHEI physical habitat assessment can be conducted at any time of the year, but must be conducted when the stream is under seasonal base flow conditions. Base flow conditions in small headwater streams recover quickly after rain events, usually within 24 hours. Evidence of elevated flows due to runoff consists of observation of surface runoff draining into the stream, stream water depths near or above the bankfull depth (see [Section 5.3.3](#)), and elevated turbidity.

Biological sampling during drought conditions can also result in misclassification of biotic potential. Lacking other information, the 7Q10 value from the nearest hydrologic unit as reported by the USGS can be used to estimate critical low flow on the date of assessment (Straub, 2001). The 7Q10 flow is used in OAC 3745-205 (A) to protect the aquatic life potential of surface waters in Ohio from chronic stressors.

Evaluations of PHWH stream using the HHEI can be done at any time of the year to determine *potential* class of primary headwater stream, with the understanding that the HHEI metrics have been selected, and weights adjusted, to allow for statistical protection of Class III-PHWH streams during the summertime low flow period of the year. A sampling period of June through September will best distinguish the various classes of PHWH streams. However, biological sampling can be conducted at any time

of the year as long as limitations in data interpretation resulting from seasonal effects are borne in mind. Vertebrates that live in cool spring-fed PHWH streams are present throughout the year because they are adapted to permanent flow conditions. For amphibians, it is the gilled larvae that are most sensitive to stream dessication.

Collection of a benthic macroinvertebrate voucher sample to verify the presence or absence of cool water adapted taxa can also be conducted at any time of the year. Likewise, a rapid bio-assessment of benthic macroinvertebrates using the Headwater Habitat Macroinvertebrate Evaluation Index (HMF EI) procedure (Section 6.3.1) also can be used at any time of the year, but is more representative during the summer sampling period (June through September). There is a taxa increase associated with spring emerging macroinvertebrate fauna (January through May) and sampling efficiency may decline latter in the year due to leaf-fall (October through December).

When multiple samples are collected at the same location at different times of the year, the measurements taken during the June through September time period are used to distinguish PHWH stream classes. When multiple samples are collected within the June through September time period, a weight of evidence approach should be used to determine the appropriate stream classification. Special precautions should be used when sampling from October through December after leaf-fall has occurred. Accumulated leaf litter present in small streams at this time of the year will often mask stream substrate conditions and make it difficult to visually locate stream dwelling vertebrates. For dry stream channels, the minimum level of documentation required is a habitat evaluation using the HHEI after the stream has been thoroughly evaluated to determine that interstitial perennial flow or permanent pools are not present.

### **2.3 Equipment Check List**

An equipment checklist for conducting chemical, physical and biological measurements is included as Attachment 2 of this manual.

### **2.4 Reference Materials**

Sources of additional reference for conducting physical stream measurements used in this manual can be found in Rosgen (1996), Rankin (1989), and the most recent field manual for the QHEI methodology (Ohio EPA, 2006 a). Field chemical sampling follows procedures as given in the Manual of Ohio EPA Surveillance Methods and Quality Assurance Practices (Ohio EPA, 2006 b). Recommended general reference materials for macroinvertebrate taxonomic identifications are Merritt et al. (2008), Smith (2001), Voshell (2002), and Bouchard (2004). References for the identification of macroinvertebrates to the lowest taxonomic level necessary to determine the number of cool and cold water adapted species of benthic macroinvertebrates are listed in the Ohio EPA guidance manual for conducting biological assessments (Ohio EPA, 2008 b).



Fish should be identified using Trautman (1981), "The Fishes of Ohio". Salamanders should be identified to the species level using "The Salamanders of Ohio" (Pfungsten and Downs, 1989), and/or "Salamanders of the United States and Canada" (Petranka, 1998). Both of these references have keys for adults and larvae with numerous photographs of various life stages of salamanders found in Ohio. Other useful references for Ohio amphibians are the Field Guide to Reptiles and Amphibians by Conant and Collins (1991) and a guide to Ohio amphibians developed by the ODNR Division of Wildlife (ODNR, 2008). ODNR also provides an on-line guide to amphibians that provides life history and identification information at the following link: <http://ohiodnr.com/tabid/20293/Default.aspx>. Pfungsten (1998) and Pfungsten and Matson (2003) provide updated range distribution maps, by county, for amphibians in Ohio.

### 3.0 Stream Reach Delineation and Site Selection

#### 3.1 PHWH Streams and Stream Reaches

The PHWH stream evaluation process consists of a combination of physical, chemical, and biological characterization of a **primary headwater stream reach**. The PHWH stream evaluation process consists of a combination of physical, chemical, and biological characterization of a **primary headwater stream reach**. For the purposes of a PHWH evaluation process, a stream is defined as a surface watercourse having a channel (as defined in ORC 6105.01) with well defined bed and banks, either natural or artificial, which confines and conducts continuous or periodical flowing water.

A stream reach is defined as a stream with a continuous channel bed up to 200 ft (61 m) length, a modification of the stream reach concept adopted by the Government of British Columbia (1998). Stream reaches for a PHWH assessment may be shorter than 200 ft in situations where tributaries have a junction with mainstem PHWH streams or where features within the stream channel (either natural or artificial) warrant restricting the evaluation reach to a distance less than 200 feet of channel length. Such tributaries will usually be "first order" streams at the NRCS county soil mapping scale (see [Figure 4](#)). Where deemed appropriate, these first order tributaries can be evaluated as being part of the larger PHWH mainstem. The mainstem of a PHWH stream drainage is the channel with the longest length that forms a junction with a larger named stream (see [Figure 5](#)). It must be noted that the use of data for stream reaches that are less than 200 ft may be suspect since the PHWH methodology is calibrated for this length, especially the physical measurements related to the HHEI.

Discrete stream reach boundaries are used to divide the stream channel into consecutive watercourse units for standardized assessment. At the headwaters of a watercourse, the location of the upper boundary of the uppermost stream reach is the

location where the first (or last, depending on direction of travel) evidence is found of scour through the mineral substrate or alluvial deposition (Government of British Columbia, 1998). A 200 ft (61 m) distance was selected because this was the distance used to calibrate the association between biological and habitat variables during the 1999 and 2000 calibration survey. This length of stream allows for a complete assessment of the natural scale of habitat variability that is present in these types of headwater streams.

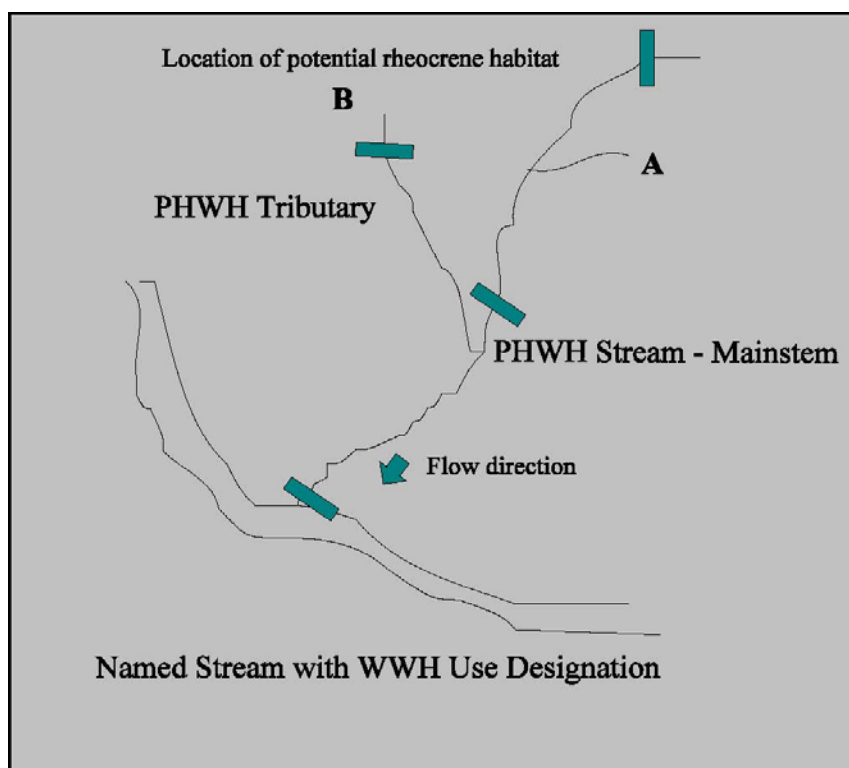

**Figure 5.** Hypothetical relationship of the primary headwater stream reach concept, showing 200 ft (61 m) upper and lower reach boundaries (dark rectangles). Delineation always begins at the most lower downstream location (or the lower property boundary). Total length of PHWH stream mainstem in this example is 430 ft (131 m). Small tributary (A) in upper zone of the PHWH mainstem may be included in assessment of that stream reach, or it may require its own assessment if it differs significantly from the mainstem conditions. PHWH tributary (B) receives its own 200 ft (61 m) stream reach assessment. The small section above the upper reach boundary for (B) may be included in the assessment of the lower 200 ft (61 m) section. The stream section near (B) would represent the potential location of a “rheocrene” habitat. The river mile (RM) where PHWH mainstem empties into the WWH designated stream should be recorded, as well as the RM location where PHWH tributary (B) empties into the PHWH mainstem.

Following the desktop evaluation to map and identify stream reach features and to delineate watershed boundaries, the physical, chemical, and biological characteristics of the stream can be determined in the field. Marked variability in land use or channel character observed within a stream reach should be noted during the site visit. The stream delineation always begins at the most lower downstream location, or the lower limits of a property boundary, as shown in Figure 5. If a stream reach is dissected by natural geological features such as a bed-rock outcropping, the length of the stream reach for assessment can be adjusted accordingly.

### **3.2 Site Selection**

It is anticipated that sampling of PHWH streams will occur for a variety of reasons, including but not limited to the following:

1. to delineate the total number, and total linear feet, of different classes (I, II, III, or modified PHWH classes) of primary headwater streams present within a specified property boundary (for example, as required for a CWA Section 401 water quality certification);
2. to delineate the relative number and percentage of PHWH stream types that may be impacted by extensive road building, pipeline, or power line projects that may affect many numerous potential PHWH streams;
3. to determine the existing aquatic life use (primary headwater or another tiered aquatic life use) and assign the appropriate class of primary headwater if necessary when considering NPDES permit applications or CWA section 401 water quality certifications;
4. to determine if a wastewater discharge, or other environmental alteration, is having a significant impact on the chemistry and/or biology of a primary headwater stream;
5. as a standardized evaluation protocol used in association with land use planning, stormwater management, or scientific surveys related to PHWH streams.

In the first situation above, all PHWH streams on the property should be mapped and delineated using 200 ft stream reach assessments. In the second situation, photographs and HHEI evaluations at discrete locations where PHWH channels will be crossed can be used to quickly estimate the relative percentage of different PHWH classes that will potentially be impacted by various project routes across the landscape. In the third situation, a multiple number (3-5) of discrete 200 ft stream reach assessments should be conducted along the length of the mainstem PHWH channel. Areas of recent habitat modification should be avoided in these types of PHWH assessments. In the fourth situation, 200 ft stream reaches should be identified upstream (reference site) and downstream from the wastewater discharge, or source of impact. Potential chemical impacts should be evaluated against water quality criteria

found in OAC Chapter 3745-1. Potential biological impacts should be evaluated using the sample methods found in this manual. In the final example, study plans should incorporate sufficient coverage of streams to accomplish the data quality objectives and scale of resolution necessary to meet the goals of the study in question.

### **3.3 QHEI vs. HHEI Evaluation in Headwater Streams**

If watershed size is greater than 1.0 mi<sup>2</sup> or natural deep pools are greater than 40 cm regardless of watershed size, a Qualitative Habitat Evaluation Index (QHEI) evaluation should be completed in accordance with standard Ohio EPA procedures (Rankin, 1989; Ohio EPA, 2006 a). The QHEI evaluation can be used to determine if the stream has potential to support a WWH community of fish, and has been used to assign aquatic life use designations for streams with drainage areas greater than 1.0 mi<sup>2</sup>. The decision making flow chart found in Figures 15 and 16 of Rankin (1989) should be used to determine if the stream has WWH potential using the QHEI technique. The stream length for a QHEI evaluation in a headwater stream should extend a minimal distance of 100 m and should incorporate the entire 200 ft PHWH stream reach.

If deemed appropriate by a qualified biologist, a HHEI habitat evaluation can also be conducted in conjunction with the QHEI evaluation in streams where watershed area is less than 1.0 mi<sup>2</sup>, but deep pools are greater than 40 cm, to insure correct classification of the aquatic life use potential. These types of decisions are best left to a biologist trained in the use of both the QHEI and HHEI evaluation methods. However, the HHEI should be used with caution in rheocrene habitats (see discussion in [Section 4.0](#) of this manual), and in streams with drainage areas greater than 1.0 mi<sup>2</sup> (even if the stream is ephemeral), since the index was not calibrated using sufficient data for these types of habitats. The minimum level of PHWH assessment for stream reaches that have been thoroughly inspected and which are found to be dry is the completion of an HHEI scoring evaluation.

### **4.0 Rheocrene Habitats and Seepage Areas**

Where deep groundwater (saturated zone) suddenly emerges to the land surface from an underground aquifer, a "spring" type aquatic habitat is formed. There are three general types of springs: (1) those that form a well defined channel (rheocrene); (2) those that form small pools or basins (limnocrene); and (3) those that form a marsh, or swamp (helocrene). Springs are unique freshwater ecosystems because their thermal, physical and chemical environments are usually more stable. In Ohio, persistent springs are of cold groundwater origin and maintain relatively constant temperatures throughout the year. They are warmer in winter and colder in summer than surface water recharge streams. Hot springs are not known to exist in Ohio. The type of biology present in springs will vary according to the type of spring that is formed (i.e.,

rheocrene, limnocrene, helocrene). Helocrene habitats are best evaluated using Ohio EPA wetland monitoring techniques (Mack, 2001; Micacchion, 2002), which are available online at:

<http://www.epa.ohio.gov/dsw/wetlands/WetlandEcologySection.aspx>

For the purposes of a PHWH stream assessment, the potential location of a "rheocrene" type of habitat will be identified if the stream under investigation has constant flowing water, forms a defined bed-bank, and has a watershed size less than 0.1 mi<sup>2</sup> (25.9 ha). In some cases the HHEI cannot accurately differentiate biological communities in rheocrene habitats and should not be used as the sole evaluation methodology in these situations (see [Section 5.3](#) and [Figure 15](#)). Following the decision-making flow chart (Figure 15), a biological survey for amphibians and benthic macroinvertebrates must be conducted in potential rheocrene habitats when the watershed area is less than 0.1 mi<sup>2</sup> (25.9 ha), the stream is flowing, the HHEI score for the site is greater than 30 points and less than 50 points, and the percent of large substrates (boulder, bedrock, and cobble) is less than 10% of the total substrate composition.

The proper PHWH stream classification to be given to waterways that meet the definition for a rheocrene habitat will be based on the types of vertebrate and benthic macroinvertebrate species present, as determined by the biological methods outlined in Section 6 of this manual. Seepage areas with diffuse flow that have wide and very shallow channels, and do not have a defined bed-bank, fall outside the assessment methods of this manual, however, they may be wetlands, thus the wetland assessment methods of Ohio EPA (Mack, 2001; Micacchion, 2002) may apply. The habitat comprising the zone of saturated sediments beneath and adjacent to an active stream channel that is available for aquatic organisms is called the hyporheic zone. This zone is the biologically and chemically active interface or ecotone among the atmosphere, land, surface waters and ground waters. This manual does not address sampling techniques to be used in hyporheic habitats.

## **5.0 Primary Headwater Habitat (PHWH) Stream Evaluation [stream less than 1.0 mi<sup>2</sup> (259 ha) and deep pools less than 40 cm]**

If the watershed size is less than 1.0 mi<sup>2</sup> (259 ha), and deep pools are less than 40 cm, a primary headwater habitat stream evaluation must be completed. A copy of the form to be used to record data is provided in Attachment 1, and is referred to as the "PHWH Form" throughout this manual. This section of the manual provides instructions for collecting the essential data needed to complete the PHWH Form. The PHWH Form is to be used to record all field measures and observations for physical (i.e., HHEI), and biological assessments. The PHWH Form is divided into four (4) pages. Detailed instructions for completion of each page follows:

**PHWH FORM - PAGE 1**

**5.1 General Stream Information**

**OhioEPA** Primary Headwater Habitat Evaluation Form    
HHEI Score (sum of metrics 1, 2, 3) :  

---

SITE NAME/LOCATION \_\_\_\_\_

\_\_\_\_\_ SITE NUMBER \_\_\_\_\_ RIVER BASIN \_\_\_\_\_ DRAINAGE AREA (mi<sup>2</sup>) \_\_\_\_\_

LENGTH OF STREAM REACH (ft) \_\_\_\_\_ LAT. \_\_\_\_\_ LONG. \_\_\_\_\_ RIVER CODE \_\_\_\_\_ RIVER MILE \_\_\_\_\_

DATE \_\_\_\_\_ SCORER \_\_\_\_\_ COMMENTS \_\_\_\_\_

Provide the site descriptive information as requested on the top of the first page of the PHWH Form. Information should be provided with enough specifics to allow for return visits to the same location. Observations on landmarks, etc. are important in order to relocate the site at a later time. The river basin represents the major basin in the stream network that the PHWH stream ultimately flows into. River code information specific to the Ohio EPA data tracking system and can be left blank for non-Ohio EPA users.

Using either a 7.5 minute series USGS topographic map, or a NRCS county soil map, determine the upstream drainage area for the PHWH stream segment under investigation. It is likely that small headwater streams will not be identified at the USGS 1:24,000 mapping scale, in which case it will be necessary to determine stream length by connecting elevation contour lines. Record the date of the assessment and the name of the scorer in the space provided at the top of the PHWH Form.

Latitude and longitude can be determined using a Global Positioning System (GPS) unit in the field, estimated from a 7.5 min. series USGS topographic map using standardized measurement tools, or from one of the many free or fee based internet based topographic mapping sites such as Google Earth, Terra Server, Topozone, etc. The latitude and longitude should be identified from the center point of the 200 ft reach and should be reported on the PHWH Form in decimal degrees with negative values reported for west longitude values in the dd.ddddd, -ddd.ddddd format.

Example conversions:

$$N 41^{\circ} 45' 23.2'' = 41 + (45 \div 60) + (23.2 \div 3600) = 41 + 0.75 + 0.00644 =$$

**41.75644**

$$W 80^{\circ} 25' 13.1'' = -1 \times [80 + (25 \div 60) + (13.1 \div 3600)] = -1 \times (80 + 0.41667 + 0.00364) =$$

**-80.42031**

Drainage areas for the watershed upstream of the evaluated reach can be determined in a number of different ways including the use of a planimeter over a topographic map on which the watershed boundaries have been determined. Computer aids using GIS software can also be used to accurately calculate upstream drainage areas. A very useful on-line resource developed by USGS in cooperation with other federal and state agencies for determining watershed areas is the Ohio STREAMSTATS web page (<http://water.usgs.gov/osw/streamstats/ohio.html>). The STREAMSTATS web page uses an interactive mapping tool to delineate drainage basins and provide data regarding watershed areas and available flow and land use data (Figures 6 and 7). Although the mapping scale varies somewhat across various regions in Ohio, in many locales the scale of the underlying stream layer is suitable for the PHWH universe.

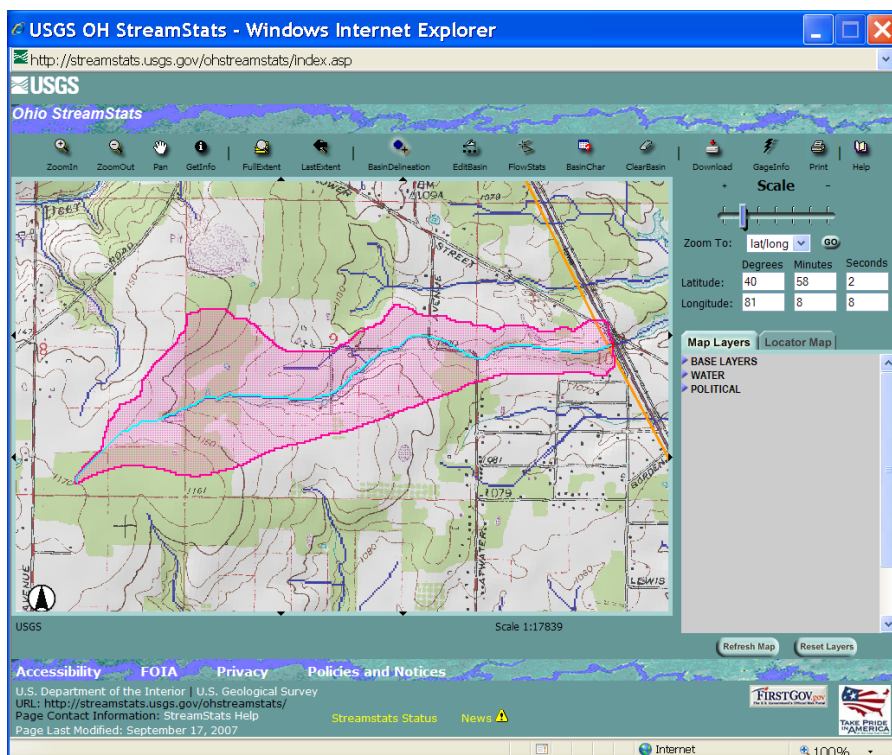

**Figure 6.** Example watershed delineation from the Ohio STREAMSTATS web page.  
<http://water.usgs.gov/osw/streamstats/ohio.html>

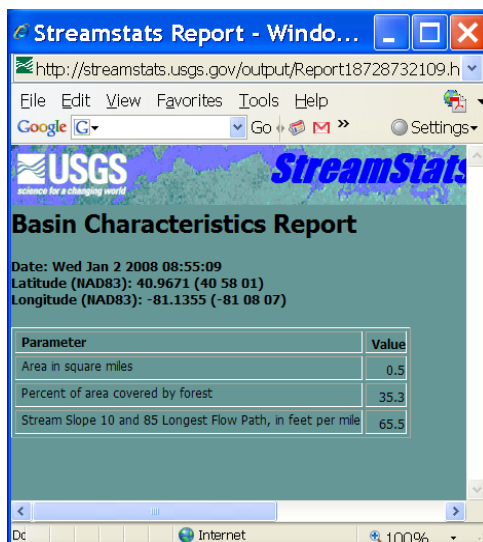

**Figure 7.** Example of basin data provided from the Ohio STREAMSTATS web page following watershed delineation.

## 5.2 Channel Modification Category Determination

**STREAM CHANNEL MODIFICATIONS:**  NONE / NATURAL CHANNEL  RECOVERED  RECOVERING  RECENT OR NO RECOVERY

The PHWH field evaluation process for a stream reach begins with a determination of whether or not the stream channel has been modified by channelization. A determination must be made as to the extent the channel geomorphology has been modified and sinuosity reduced as well as the degree of recovery that has occurred over time resulting in re-naturalization from past channel modifications. Guidelines to determine the proper characterization category are listed in Table 3 and are further described in the Ohio EPA QHEI guidance (Ohio EPA, 2006 a – see discussion for Metric 3: Channel Morphology). Streams in the “NONE/NATURAL CHANNEL” and the “RECOVERED” categories are considered **“natural”** channels for HHEI classification (Figure 15), while those in the “RECOVERING” and the “RECENT OR NO RECOVERY” categories are considered **“modified”** channels.

On the front of the PHWH Form, determine the proper level of channel modification and check the appropriate box in the area provided next to the heading “Stream Channel Modifications”. Research regarding historical land use patterns for an area is often useful in properly completing this classification of the evaluated stream reach. In addition, the degree of natural features which should be present in any given stream reach must be taken into account in light of the watershed characteristics, flow patterns and geologic setting of the evaluated reach when categorizing the reach when assigning the stream channel modification categorization.



**Table 3.** Guidelines for the determination of the stream channel modification category for the HHEI form.

<b>Stream Channel Modification Category</b>	<b>Narrative Description</b>
NONE/NATURAL CHANNEL	<p>No obvious historical relocation or alteration of the stream channel is evident.</p> <p>The stream channel is characterized by the presence of riffles and pools, heterogenous substrate deposition, the presence of point bars or other evidence of floodplain sediment deposition, appropriate stream channel sinuosity for the setting of the stream in the landscape, varied water depths and current velocity (when flowing), no obvious evidence of current or past bank shaping or armoring activities is present.</p> <p>Natural wooded or wetland riparian vegetation dominates the stream margin.</p>
RECOVERED	<p>Visual evidence is present of historical channel alteration, channel relocation, bank shaping, or armoring. However, the stream has fully recovered many of the natural characteristics as listed above.</p> <p>Wooded or wetland riparian vegetation in either a natural condition or exhibiting significant recovery is present along the stream margin.</p>
RECOVERING	<p>Visual evidence is present of historical channel alteration, channel relocation, bank shaping, or armoring.</p> <p>The stream is in the process of adjustment, but has not fully recovered the natural characteristics listed above.</p> <p>Stream channel sinuosity may be less than appropriate for the setting of the stream in the landscape.</p> <p>Wooded or wetland riparian vegetation may be present along the stream margins, but is in the early stages of re-growth.</p>
RECENT OR NO RECOVERY	<p>Visual evidence of stream channel relocation or alteration (including bank shaping and/or armoring) exists where few if any of the natural stream characteristics listed above are present.</p> <p>Typical appearance of the stream channels in this condition reveals obvious signs of channel straightening, bank alteration, floodplain alterations, riparian vegetation removal, entrenchment, and trapezoidal channel geometry.</p> <p>Highly modified streams tend to have uniform depths, over-wide channels, homogenous substrate types, high levels of substrate embeddedness, and low sinuosity.</p>

### 5.3 Calculation of the Headwater Habitat Evaluation Index (HHEI)

The HHEI is a multi-parameter rapid assessment of the physical habitat that can be used to predict the biological potential of most PHWH streams. The HHEI is calibrated to streams with watershed size less than 1.0 mi<sup>2</sup> where the deepest pools of water are less than 40.0 cm (15.7 in.), and should only be used with extreme caution outside of these limitations. All HHEI measurements are to be made within the 200 ft (61 m) stream reach zone. On the front of the PHWH Form, within the large box, are three field measurements that must be taken to calculate a final HHEI score. Information obtained from the HHEI scoring is then used to determine the biological potential of the PHWH stream following the HHEI decision-making flowchart in Figure 15.

#### 5.3.1

#### HHEI Metric # 1: Stream Channel Substrate

1. **SUBSTRATE** (Estimate percent of every type of substrate present. Check *ONLY two* predominant substrate *TYPE* boxes (Max of 40). Add total number of significant substrate types found (Max of 8). Final metric score is sum of boxes A & B.

TYPE	PERCENT	TYPE	PERCENT
<input type="checkbox"/> <input type="checkbox"/> BLDR SLABS [16 pts]	_____	<input type="checkbox"/> <input type="checkbox"/> SILT [3 pt]	_____
<input type="checkbox"/> <input type="checkbox"/> BOULDER (>256 mm) [16 pts]	_____	<input type="checkbox"/> <input type="checkbox"/> LEAF PACK/WOODY DEBRIS [3 pts]	_____
<input type="checkbox"/> <input type="checkbox"/> BEDROCK [16 pt]	_____	<input type="checkbox"/> <input type="checkbox"/> FINE DETRITUS [3 pts]	_____
<input type="checkbox"/> <input type="checkbox"/> COBBLE (65-256 mm) [12 pts]	_____	<input type="checkbox"/> <input type="checkbox"/> CLAY or HARDPAN [0 pt]	_____
<input type="checkbox"/> <input type="checkbox"/> GRAVEL (2-64 mm) [9 pts]	_____	<input type="checkbox"/> <input type="checkbox"/> MUCK [0 pts]	_____
<input type="checkbox"/> <input type="checkbox"/> SAND (<2 mm) [6 pts]	_____	<input type="checkbox"/> <input type="checkbox"/> ARTIFICIAL [3 pts]	_____

Total of Percentages of Bldr Slabs, Boulder, Cobble, Bedrock \_\_\_\_\_ (A)  (B)

SCORE OF TWO MOST PREDOMINATE SUBSTRATE TYPES:  TOTAL NUMBER OF SUBSTRATE TYPES:

**HHEI Metric Points**

Substrate Max = 40

A + B

Next to temperature and an adequate supply of water, the composition of the substrate found in the stream channel is the most important feature that predicts biological potential. Acting in conjunction with other physical characteristics of the stream channel, the substrate composition is indicative of stream hydrology, the dynamics of sediment transport to downstream water bodies, and the type of biology present. Class III-PHWH fauna are seldom found in streams dominated by fine grained or monotonous substrate types. This metric is calibrated to separate Class III-PHWH streams from all other types of headwater streams.

The characterization of the channel substrate includes a visual assessment of the 200 ft (61 m) stream reach using a reasonably detailed evaluation of both the dominant types of substrate, and the total number of substrate types. For flowing streams, the substrate evaluation is restricted to the **wetted channel only** (locales where obligate aquatic organisms can survive). For dry stream channels, the substrate evaluation includes the **entire** channel bottom within the bounds of the bankfull width.

To complete the substrate scoring section of the PWH Form, the following protocol must be followed:

1. Estimate and record the presence and percentage (%) of all of the substrate types observed that are potentially biologically significant (i.e. provide usable habitat for obligate aquatic fauna) in the blanks included in the "PERCENT" column of the form. As a general practice, this will usually, but not necessarily always, be limited to substrate types estimated to cover 1% or greater of the stream channel. **A detailed estimate of the percent (%) coverage of each substrate type is required in order to complete the HHEI decision flowchart found in Figure 15.** Ensure that the substrate percentages add up to 100% when entry of the substrate metric information is complete.
2. Record the two most dominant substrate types by checking the appropriate two boxes in the "TYPE" column adjacent to the names of the substrate types estimated to be dominant in the evaluated reach. Note that only two substrate type boxes can be checked on the form and that only these two substrate types are used to calculate the score entered in Box A of the substrate metric. If it is determined that one type of substrate completely dominates the stream channel within the reach (based upon one substrate type exceeding 90% of the coverage and no other type exceeding 5%), check both substrate type boxes next to the appropriate substrate type and check no other boxes in the "TYPE" column.
3. Add the scores associated with the two dominant substrate types and record the sum in Box A of the substrate metric section (note: if there is only one dominant substrate type, the score in Box A equals two times the score associated with the substrate type).
4. Count the number of substrate types observed (those for which percentages are estimated) and enter the result in Box B of the substrate metric section. Box B has a maximum possible score of 8 points, even if more than 8 functional substrate types are present.
5. Add the score in Box A to the score in Box B and enter the result in the Substrate metric box on the right hand side of the PWH Form. [Note that the substrate metric score cannot exceed 40 points, see item 4 above]
6. Add the percent coverage of Bedrock, Boulders, Boulder Slabs, and Cobble and record the sum as a percentage in the space to the left of Box A in the substrate metric section of the PWH form. This estimate may be important when categorizing the stream using the decision flow chart (Figure 15).

An example of a properly completed substrate metric section of the PHWH form is provided in Figure 8.

<b>1. SUBSTRATE (Estimate percent of every type of substrate present. Check ONLY two predominant substrate TYPE boxes (Max of 40). Add total number of significant substrate types found (Max of 8). Final metric score is sum of boxes A &amp; B.</b>						<b>HHEI Metric Points</b>  Substrate Max = 40  <div style="border: 1px solid black; padding: 5px; width: 40px; margin: 0 auto; text-align: center;">18</div> A + B
<b>TYPE</b>		<b>PERCENT</b>	<b>TYPE</b>		<b>PERCENT</b>	
<input type="checkbox"/>	BLDR SLABS [16 pts]		<input checked="" type="checkbox"/>	SILT [3 pt]	43%	
<input type="checkbox"/>	BOULDER (>256 mm) [16 pts]	2%	<input type="checkbox"/>	LEAF PACK/WOODY DEBRIS [3 pts]	10%	
<input type="checkbox"/>	BEDROCK [16 pt]		<input type="checkbox"/>	FINE DETRITUS [3 pts]		
<input type="checkbox"/>	COBBLE (65-256 mm) [12 pts]	5%	<input type="checkbox"/>	CLAY or HARDPAN [0 pt]		
<input checked="" type="checkbox"/>	GRAVEL (2-64 mm) [9 pts]	25%	<input type="checkbox"/>	MUCK [0 pts]		
<input type="checkbox"/>	SAND (<2 mm) [6 pts]	15%	<input type="checkbox"/>	ARTIFICIAL [3 pts]		
Total of Percentages of Bldr Slabs, Boulder, Cobble, Bedrock		7%	(A)	(B)		
			12	6		
SCORE OF TWO MOST PREDOMINATE SUBSTRATE TYPES:			TOTAL NUMBER OF SUBSTRATE TYPES:			

**Figure 8.** An example of a completed Substrate Metric section from page 1 of the PHWH Form. Note that only two substrate types are checked under the "TYPE" column and that these scores are added to produce the score in Box A. The percentage estimates for observed substrate types are entered in the "PERCENT" column, and the total percentages of boulder slabs, boulders, bedrock and cobble are added and recorded in the space to the left of Box A. The total number of substrate types are counted and the result entered in Box B. Scores from Box A and Box B are added to provide the Substrate Metric score and the result is recorded in the box provided in "HHEI Metric Points" column on the right hand side of the form.

Although not required, a pebble-count method can be used to quantify the percentages of the most common substrate types. However, the user should note that substrate types that are visually observed and deemed to be biologically available habitat within the evaluated reach must always be counted toward the scoring for the number of substrate types present regardless of whether or not that substrate type was encountered during a pebble count analysis. The HHEI substrate metric was calibrated based upon use of the visual estimation method.

Experience has shown that pebble count analyses often miss one or more substrate types that can be visually observed and which are available to aquatic organisms. In addition, it has also been observed that pebble count analyses tend to under-estimate the percent composition of large substrates in PHWH stream evaluations. Therefore, extreme care should be taken to ensure that the minimum number of observations made during pebble counts is sufficient to capture the true variability of the substrate in the evaluated stream and that this data is verified by cross checking with visual observations. Pebble-count data can be recorded on the field form provided in

Attachment 4. For further information regarding conducting, recording, and interpreting pebble count data, the following references can be consulted: Bevenger and King (1995); Kondolf (1995); Kondolf and Li (1992); Rosgen (1996); and Wolman (1954).

The measurement of substrate particles during an HHEI assessment is conducted with the use of a small metric ruler with gradations in millimeters. Measurements and size classifications are based upon the length of the intermediate axis of the particle (Figure 9). The intermediate axis is always perpendicular to the long axis of the particle. Care should be taken to measure the longest point on the particle that is perpendicular to the long axis. For particles determined to meet the definition of a boulder (see below), the ratio of the measurement of the intermediate axis to the short axis is used to distinguish between boulders and boulder-slabs (see definition below).

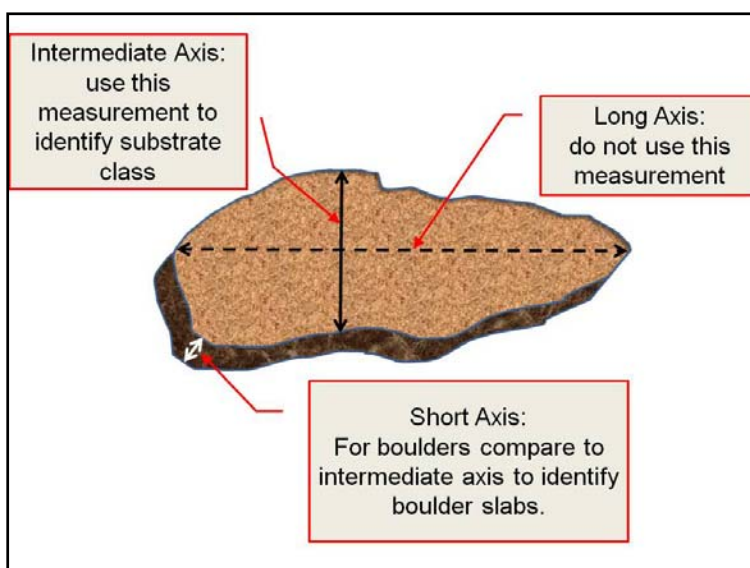

**Figure 9.** A stylized representation of a substrate particle indicating the proper way to determine the size category for classification.

A summary of definitions for the nine major substrate types that apply to the HHEI evaluation follows:

- **Bedrock Substrates:**

Streambed characterized by the presence of monolithic bedrock outcropping. May be fractured, and often associated with boulder and cobble substrates. Since PHWH streams with bedrock substrate are often associated with the surface discharge of groundwater, a high degree of association was found at these sites with the presence of cool-cold water native fauna of obligate salamanders and benthic macroinvertebrates.

- **Boulder Substrates:**

These substrate types provide excellent habitat for obligate aquatic salamanders, fish, and benthic macroinvertebrates because of their inherent stability. They are separated into two types:

- **Boulder Slabs:** Greater than 256 mm, flat instead of round (see [Figure 8](#): ratio of intermediate axis to the short axis  $>2$ ).
- **Boulders:** Greater than 256 mm, round, (see [Figure 8](#): ratio of intermediate axis to the short axis  $\leq 2$ ).

- **Cobble Substrates:**

Stones with intermediate axis lengths greater than 64 mm and less than 256 mm. This substrate type has a strong association with Class III-PHWH streams.

- **Gravel Substrates:**

Particles 64 mm or less, but at least 2 mm in size. This substrate type is neutral in its ability to separate the three classes of PHWH streams, but is often a secondary component of Class III PHWH streams.

- **Sand Substrates:**

Particles less than 2 mm in size, gritty texture when rubbed between fingers. This substrate type is often a secondary component of Class III-PHWH streams.

- **Silt Substrates:**

Substrate particles less than 0.6 mm in size, exhibiting a greasy texture when rubbed between the fingers. Silt is most often a conglomerate of eroded clays and very fine organic matter which has deposited in the stream channel. There is a negative association of silt with Class III-PHWH streams, but silts can be present in limited amounts in natural channels with low energy dynamics.

- **Clay or hardpan Substrates:**

This substrate type is typically found when the stream bed has eroded to a depositional clay layer within the underlying sub-soil. This substrate is typically hard and gummy and is difficult to penetrate. Unlike silts, this substrate type is not deposited in the stream channel by recent fluvial processes. It provides a poor habitat for most native fauna.

- **Muck Substrates:**

Muck consists of decayed organic matter with little or no clay content. Muck differs from silt in that it is almost entirely organic in nature, less dense, and more odorous. Muck differs from detritus in that it is partially decayed and not coarse or readily identifiable as to the material of origin. This substrate type is strongly associated with Class II PHWH streams. Caution should be taken to ensure that the material is not actually sludge deposited downstream of a discharge from a failing wastewater treatment system or animal management operation. In such cases, the sludge is ignored and the underlying substrate is identified and used for scoring.

- **Detritus Substrates:**

Detritus refers to the presence of partially or un-decayed sticks, wood, leaves or other plant material deposited in the stream channel. The allochthonous input of organic matter is the primary energy resource for the biological community of PHWH streams. Two categories are recognized:

- **Leaf Pack/Woody Debris:** The presence of leaf packs and woody debris provides an energy resource as well as habitat for colonization of plants and animals. Although this substrate type was found to be neutral in its ability to separate the three classes of PHWH streams, it is often found as a secondary component of Class III-PHWH streams with heterogenous substrates. It provides potential microhabitat and food source for benthic macroinvertebrates that are prey for fish and obligate aquatic salamanders. This substrate type is also positively associated with the presence of salamander larvae.

- **Fine Detritus:** This substrate type refers to fine, partially decomposed plant material which has accumulated within the stream channel as a precursor to the development of muck deposits. These materials are subject primarily to microbial decomposition processes. Fine particular organic matter may be correlated with the presence of macroinvertebrate fauna that “collect” fine organic matter as a food source.
- **Artificial Substrates:** “Artificial” substrate types include all man-made or engineered materials in the stream channel whether or not they have been intentionally placed in the stream. Artificial substrates include materials such as crushed stone (rip-rap or aggregate), concrete, bricks, lumber, trash, asphalt, metal, etc. that have either been placed in or found their way into the stream. Where engineered structures or substrates have been placed in the stream for the purposes of stream restoration, a trained biologist who determines that the placed materials are functioning as viable habitat for aquatic fauna may categorize these substrates into the appropriate substrate category associated with natural substrates (e.g. boulder, cobble, gravel, woody debris, etc.) and score the substrate metric accordingly.

### 5.3.2

#### HHEI Metric #2. Maximum Pool Depth

2.	<b>Maximum Pool Depth</b> ( <i>Measure the maximum pool depth within the 61 meter (200 ft) evaluation reach at the time of evaluation. Avoid plunge pools from road culverts or storm water pipes</i> ) (Check <i>ONLY</i> one box):	<b>Pool Depth</b> Max = 30		
<input type="checkbox"/>	> 30 centimeters [20 pts]	<input type="checkbox"/>	> 5 cm - 10 cm [15 pts]	<div style="border: 1px solid black; width: 40px; height: 40px; margin: 0 auto;"></div>
<input type="checkbox"/>	> 22.5 - 30 cm [30 pts]	<input type="checkbox"/>	< 5 cm [5 pts]	
<input type="checkbox"/>	> 10 - 22.5 cm [25 pts]	<input type="checkbox"/>	NO WATER OR MOIST CHANNEL [0 pts]	
COMMENTS _____		MAXIMUM POOL DEPTH (centimeters): <span style="border: 1px solid black; display: inline-block; width: 40px; height: 20px; vertical-align: middle;"></span>		

The maximum pool depth within the stream reach is important since it is a key indicator of whether the stream can support a well balanced fish community. Streams with pools less than 40 cm in depth during the critical low flow period of the year are less likely to have well balanced WWH fish communities (see Figure 16 in Rankin, 1989), and thus more likely to have dense populations of lungless salamanders. Maximum pool depth is also related to the type of flow present in the stream channel (i.e., continuous, intermittent, interstitial), and thus serves as a good discriminator of the various classes of PHWH streams. Scoring of the Pool Metric is based upon the maximum pool depth within the 200 ft (61 m) stream reach. In the field, several depth measurements should be taken within each pool in order to verify that the deepest point(s) have been measured.



To complete the PHWH Form, check the appropriate box for the maximum pool depth observed and record the corresponding Pool Depth metric score in the box in the right hand column of the form. If no water can be found within the evaluated reach, the Pool Metric score is zero (0). The maximum pool depth observed should be recorded to the nearest centimeter.

Care should be taken to avoid measurements in plunge pools located on the downstream ends of road culverts or other man-made structures as these depths are not characteristic of overall stream morphology. Evaluation reaches should be selected to exclude these features whenever possible. In addition, it is important to ensure that the stream is under seasonal base flow conditions (see [Section 2.2](#)) in order to properly score the Pool Metric. Since the HHEI was calibrated based upon evaluations conducted during critical low flow periods of the year (June-September), assessments conducted during high flow periods of the year may result in higher overall HHEI scores based solely upon differences in the Pool Metric score.

### 5.3.3

### HHEI Metric #3. Average Bankfull Width

3.	<b>BANK FULL WIDTH (Measured as the average of 3-4 measurements)</b> <input type="checkbox"/> > 4.0 meters (> 13') [30 pts] <input type="checkbox"/> > 3.0 m - 4.0 m (> 9' 7" - 13') [25 pts] <input type="checkbox"/> > 1.5 m - 3.0 m (> 4' 8" - 9' 7") [20 pts]	<b>(Check ONLY one box):</b> <input type="checkbox"/> > 1.0 m - 1.5 m (> 3' 3" - 4' 8") [15 pts] <input type="checkbox"/> ≤ 1.0 m (≤ 3' 3") [5 pts]	Bankfull Width Max=30
COMMENTS _____		AVERAGE BANKFULL WIDTH (meters) <input style="width: 50px; height: 20px;" type="text"/>	<input style="width: 40px; height: 20px;" type="text"/>

Bankfull width is a morphological characteristic of streams that is directly related to energy dynamics related to water discharge. The bankfull width of the stream therefore relates strongly to its annual flow condition and has been found to be a strong discriminator of the three types of PHWH streams in Ohio. The bankfull width of a stream channel should be measured in straight sections of the stream (riffle, run, or glide). Pools and bends in the stream or other areas where the stream width is affected by the deposition of debris, fallen trees, etc. should be avoided. For the purpose of this manual, the bankfull width is defined as the elevation on the stream banks where the flow is at the bankfull discharge. The bankfull discharge is defined as follows:

“ ... the discharge at which channel maintenance is the most effective, that is, the discharge at which moving sediment, forming or removing bars, forming or changing bends and meanders, and generally doing work that results in the average morphologic characteristics of channels.” Dunne and Leopold (1978).

The elevation of bankfull discharge may not be at the top of the stream bank in incised or entrenched streams. Rosgen (1996) gives several suggestions for determining bankfull width in streams:

1. "A break in slope of the banks and/or a change in the particle size distribution (since finer material is associated with deposition by overflow, rather than the deposition of coarser material within the active channel)."  
*[Note: the highest elevation of gravel and/or sand bars ("point bars") is an excellent indicator of the bankfull discharge elevation]*
2. "Evidence of an inundation feature such as small benches."
3. "Staining of rocks."
4. "Exposed root hairs below an intact soil layer indicating exposure to erosive flow."

The boundary elevation on the stream bank where terrestrial vegetation begins along the stream margin can also indicate the edge of the bankfull width (Figures 10 through 13). Although caution must be taken when evaluations are conducted under drought conditions, this is an excellent feature to use in combination with other indicators mentioned above for headwater streams.

Further guidance, including a series of training videos relating to the determination of bankfull stage, can be accessed through the USDA forest Service web page via the following link: <http://www.stream.fs.fed.us/publications/videos.html> . Users of this manual are highly encouraged to review this video training series in order to develop competence at identifying bankfull stage elevation.

Following the measurement of 3-4 bankfull widths along the evaluated stream reach, the average bankfull width (in meters) is entered into the appropriate box in the Bankfull Width Metric section on page one of the PHWH Form. The bankfull width category for the reach is checked and the corresponding metric score is entered in the box in the right hand column of the form.

In the field it will often be possible to determine the bankfull stage on only one bank of the stream. However, this point can be used to determine the bankfull elevation on the opposite bank by creating a level line across the stream from the identified bankfull elevation perpendicular to the stream flow (see [Figures 10](#) through [13](#)). The following procedure can then be used to determine the bankfull width:

1. Mark the bankfull elevation with a stake.
2. Connect a length of string to the stake at the bankfull elevation.
3. Place bubble type line level on measuring string ([Figure 14](#)).

4. Suspend the measuring string perpendicular to the stream flow from the staked location to the opposite bank.
5. Pull string taut and manipulate up and down until the line level indicates that the string is level. Mark the location where the string intersects the opposite bank.
6. Measure the distance between the marked bankfull locations on either bank of the stream.
7. Take 3-4 measurements throughout the 200 ft (61 m) stream reach and record each result. Calculate an average bankfull width for the stream segment. Record the average bankfull width on the PHWH Form in the space provided.

Line levels are readily available at home improvement and hardware stores at a reasonable cost. Ohio EPA has also had good success using carpenter's laser levels placed at the bankfull elevation to shoot the bankfull elevation of the opposing bank along a level plane. Laser levels may be ineffective on sunny days along streams with little forest canopy. For very narrow streams with highly visible bankfull indicators on both banks, the use of levels to mark the bankfull elevations may be unnecessary in order to get a valid measurement.

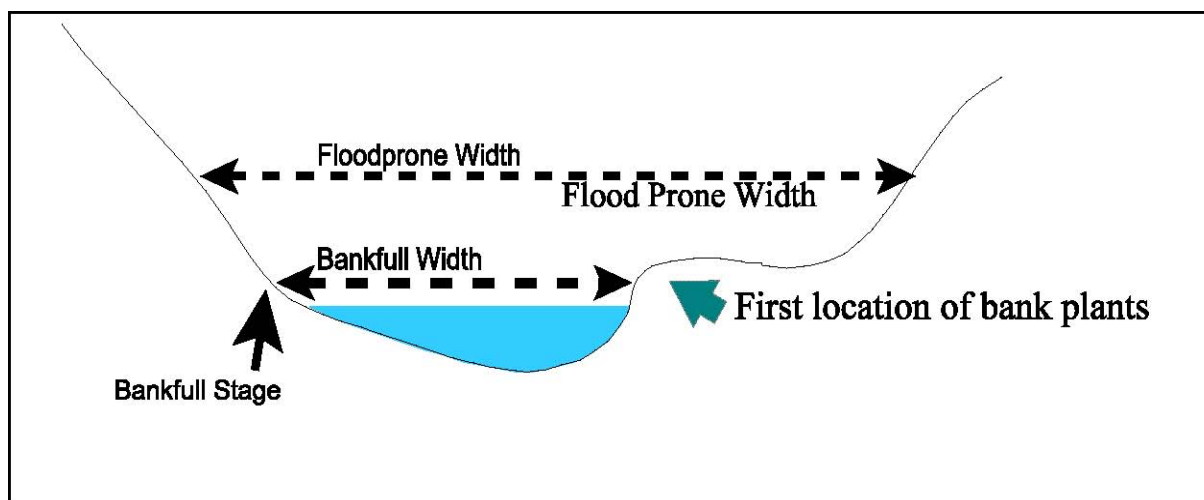

**Figure 10.** Schematic representation of the relationship of bankfull and floodprone stream widths.



**Figure 11.** Measuring bankfull width in an incised PHWH stream. Note that the bankfull indicators are below the top of the bank in this incised channel.

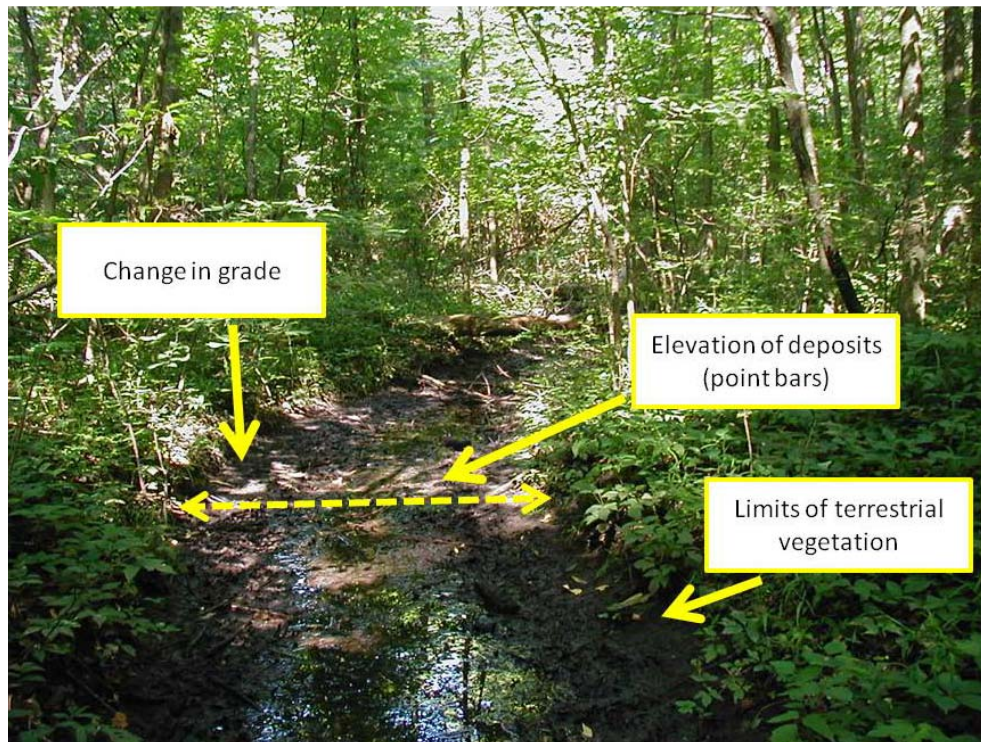

**Figure 12.** Bankfull indicators noted for a Class II PHWH stream from Fulton County, Ohio. The dashed line represents the bankfull width for this location.

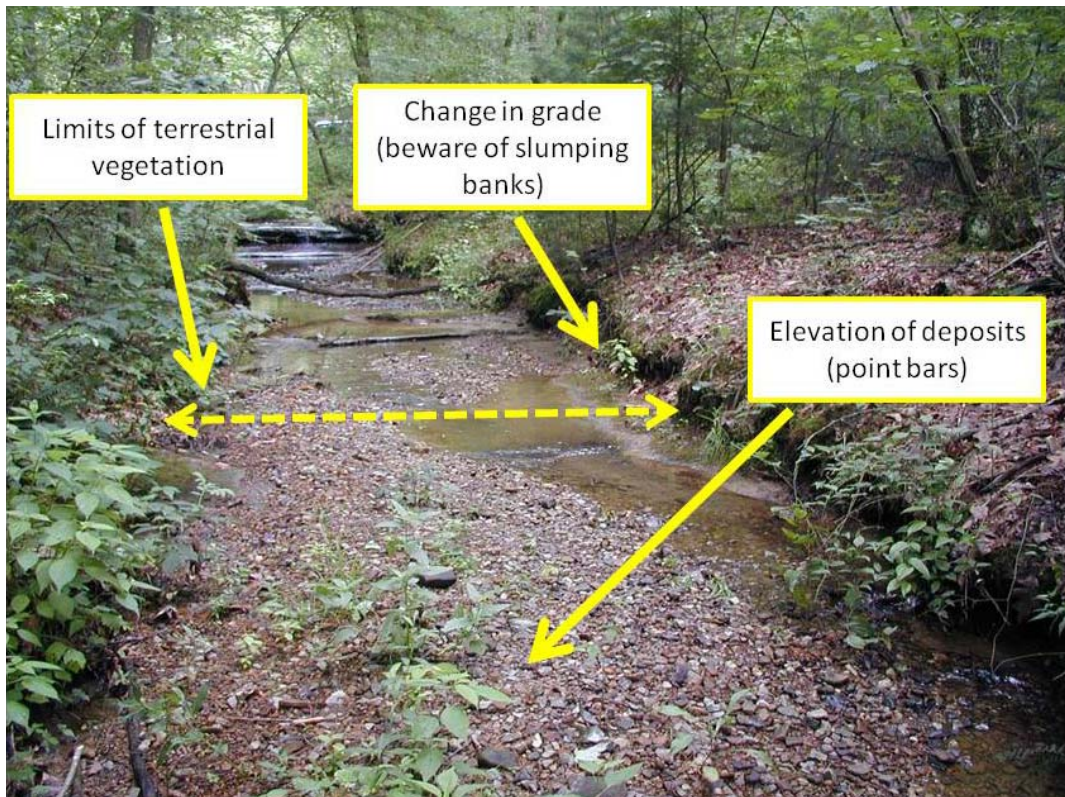

**Figure 13.** Bankfull indicators noted for a Class III PHWH stream from Hocking County, Ohio. The dashed line represents the bankfull width for this location.

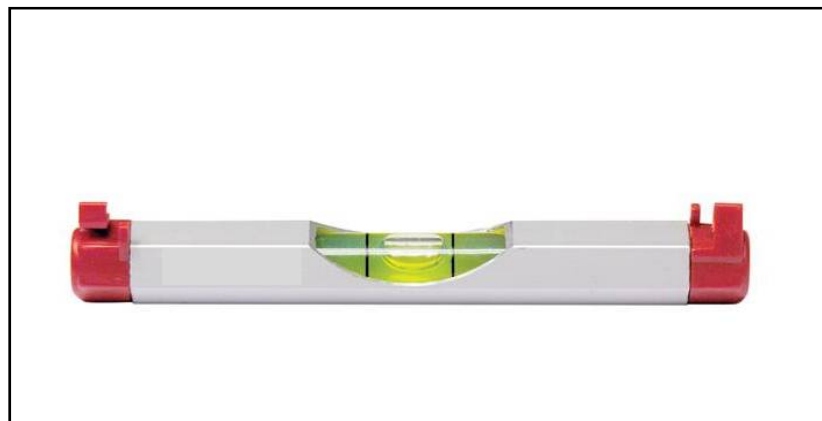

**Figure 14.** A line level. The instrument is hung from a taut string suspended between a known bankfull elevation to determine the bankfull elevation on the opposite stream bank.

### 5.3.4

#### Total HHEI Score

The total HHEI score is derived by adding the three metric scores (substrate + pool depth + bankfull width). The resulting value is then entered into the "HHEI Score" box located in the upper right hand corner of page one of the PHWH Form.

### 5.4 Using the HHEI Assessment to Assign Existing Aquatic Life Use Potential

The Ohio EPA currently uses a rapid habitat assessment tool, the QHEI, to assess the biological potential of larger streams in Ohio. As a rule of thumb, if multiple QHEI assessments along a stream corridor have an average QHEI score greater than 60 points, this information can be used to assign a Warmwater Habitat (WWH) aquatic life use designation to an undesignated stream with deep pools greater than 40 cm (see Figures 15 and 16 in Rankin, 1989). However, a QHEI less than 60 points does not necessarily suggest that a WWH use cannot be obtained, unless the QHEI score is significantly degraded due to a high number of modified metrics (see Rankin, 1989 for guidance).

In a manner similar to use of the QHEI, it is possible to use the HHEI to determine the biological potential of PHWH streams in Ohio. Whereas the QHEI is calibrated to the presence of a well balanced fish assemblage, the HHEI is calibrated to the presence or absence of salamander species with multi-year larval periods. These species often replace fish as the top vertebrate predator in perennial headwater streams. Neither the QHEI nor the HHEI are primarily calibrated to the presence or absence of well balanced benthic macroinvertebrate communities, although the HHEI can be used to predict the presence of cool water adapted species of macroinvertebrates where they are strongly associated with salamander larvae.

The decision making flowchart found in Figure 15 must be used to assign the appropriate classification to a PHWH stream when the stream classification is based solely on a HHEI assessment. This flowchart allows for both natural and modified PHWH stream channels to be placed into one of six potential PHWH stream types (Rheocrene, Class I, Class II, Class III, Modified Class I, and Modified Class II). When the results of both a biological assessment and a HHEI assessment are available, the data from the biological assessment is used to classify the PHWH stream. Exceptions to this practice are cases where there is reason to suspect that chemical toxicity or another pollution source (typically organic or nutrient enrichment) is limiting the full biological potential of the stream. If degraded water quality resulting in toxicity or enrichment is present, the HHEI assessment can be used to determine the potential aquatic life use that would be present once the chemical pollution problem is eliminated.

A similar approach is used in larger streams with the QHEI evaluation, which is used by Ohio EPA to determine if a stream has potential to attain a Warmwater Habitat fish community in the absence of chemical toxicity. Chemical-physical parameters that could affect headwater stream biology include ammonia-N, low dissolved oxygen, excessive siltation, heavy metals from mine drainage, pH, and excessive increases in water temperature.

### 5.5 Riparian Zone and Floodplain Quality

**RIPARIAN ZONE AND FLOODPLAIN QUALITY** ☆NOTE: River Left (L) and Right (R) as looking downstream☆

<u>RIPARIAN WIDTH</u>		<u>FLOODPLAIN QUALITY</u>			
L	R	L	R	L	R
<input type="checkbox"/>	<input type="checkbox"/>	<input type="checkbox"/>	<input type="checkbox"/>	<input type="checkbox"/>	<input type="checkbox"/>
(Per Bank)		(Most Predominant per Bank)			
<input type="checkbox"/>	<input type="checkbox"/>	<input type="checkbox"/>	<input type="checkbox"/>	<input type="checkbox"/>	<input type="checkbox"/>
Wide >10m		Mature Forest, Wetland		Conservation Tillage	
<input type="checkbox"/>	<input type="checkbox"/>	<input type="checkbox"/>	<input type="checkbox"/>	<input type="checkbox"/>	<input type="checkbox"/>
Moderate 5-10m		Immature Forest, Shrub or Old Field		Urban or Industrial	
<input type="checkbox"/>	<input type="checkbox"/>	<input type="checkbox"/>	<input type="checkbox"/>	<input type="checkbox"/>	<input type="checkbox"/>
Narrow <5m		Residential, Park, New Field		Open Pasture, Row Crop	
<input type="checkbox"/>	<input type="checkbox"/>	<input type="checkbox"/>	<input type="checkbox"/>	<input type="checkbox"/>	<input type="checkbox"/>
None		Fenced Pasture		Mining or Construction	
COMMENTS _____					

The riparian ecotone between the flowing water of the stream and the adjacent flood plain is critical for the fauna that lives in primary headwater streams. The riparian stream margin provides the primary source of food in the form of fallen leaves (detritus) for the benthic macroinvertebrate food web. Physical structure in the form of leaf litter and decayed logs provide shelter for amphibians and other animals. The shading provided by a well formed canopy of vegetation helps to maintain cool water temperatures in the summer months in cold-cool Class III-PHWH corridors. The riparian zone is also an important migratory corridor for many forms of wildlife including mammals, reptiles, amphibians, and birds.

The “Riparian Width” and “Floodplain Quality” check boxes on the PHWH Form are completed by checking the appropriate selection for the riparian width and land use(s) for each bank. The riparian width refers to the overall average distance from the stream bank that is vegetated by woody vegetation (mature trees and shrubs). River right and river left are determined as looking downstream. In cases where the riparian width or land use varies significantly along one or both stream banks within the stream reach being evaluated, the two most appropriate selections should be checked. It may also be of interest to record the type of plant community found in the riparian corridor of the stream reach under investigation. This information should be recorded in the comments section.

NOTE: the term “mature forest” in the PHWH context does not have the same meaning as used in wetlands assessments using the Ohio Rapid Assessment Method (ORAM). For PHWH assessments, relatively mature second or third growth forest cover (20+ year trees) should be counted as “mature forest”.

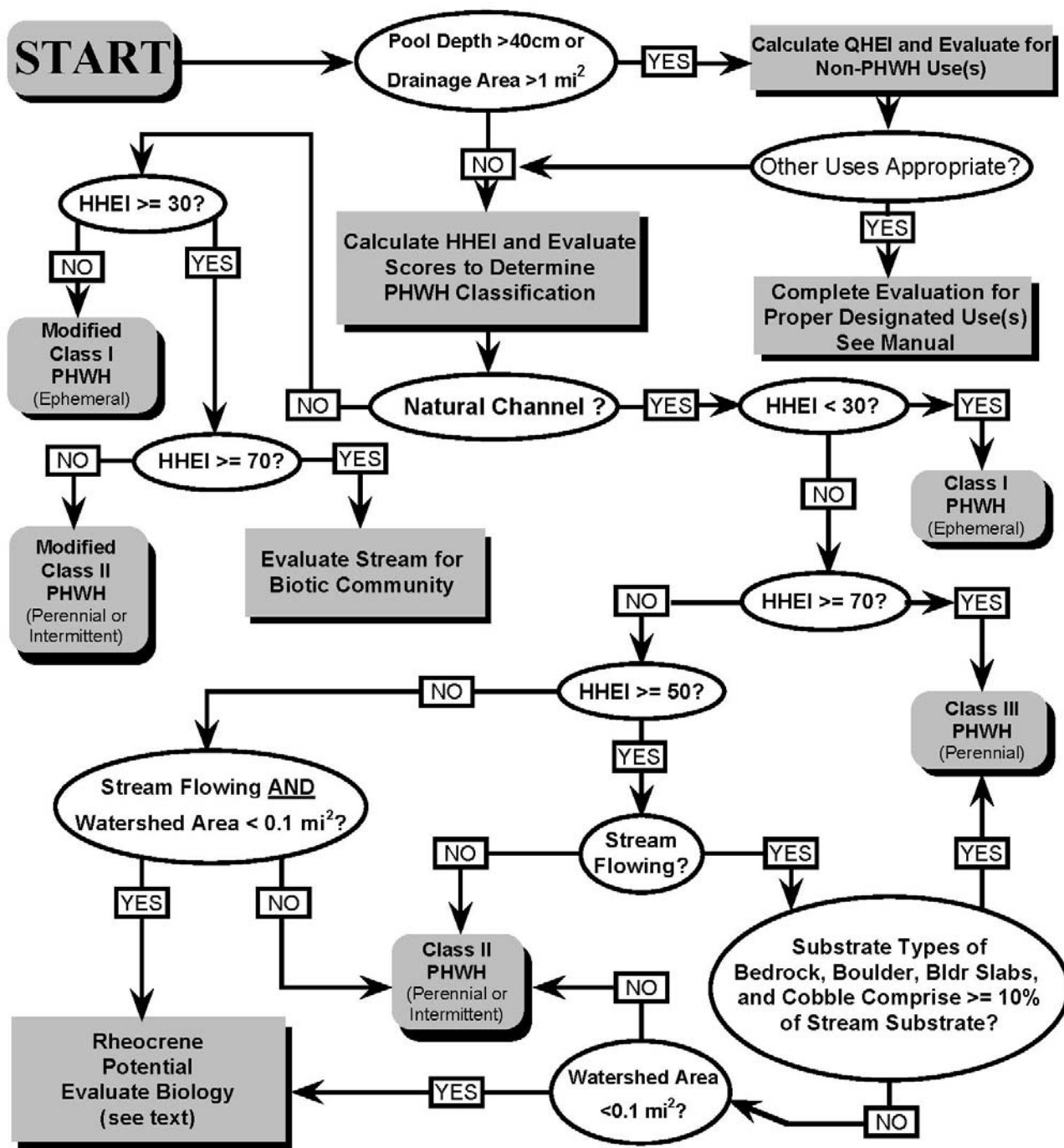

PHWH Manual, Rev. 2.0, October 2008

Figure 15. PHWH classification flow chart based on HHEI scoring.  
<http://www.epa.ohio.gov/portals/35/wqs/headwaters/HHEIFlowChart.pdf>



## 5.6 Flow Regime

**FLOW REGIME** (At Time of Evaluation) (Check *ONLY* one box):

<input type="checkbox"/>	Stream Flowing	<input type="checkbox"/>	Moist Channel, isolated pools, no flow (Intermittent)
<input type="checkbox"/>	Subsurface flow with isolated pools (Interstitial)	<input type="checkbox"/>	Dry channel, no water (Ephemeral)

COMMENTS \_\_\_\_\_

For purposes of completing an evaluation of PHWH streams, the following definitions are used to describe the apparent flow characteristics at the time of the evaluation:

**Stream Flowing:** flowing water present at time of assessment.

**Interstitial Flow with Isolated Pools:** flowing water is present in isolated pools (often widely spaced), which remain connected by subsurface flows. Dye testing may be needed to document pool connection. Alternatively, a test can be made for interstitial flow by digging away the substrate in a “dry” portion of the stream (preferably in the thalweg) to see if the substrates are saturated (i.e. water fills the hole). If the water in the hole clears of suspended silts quickly, or obvious stream flow is present, and/or the water is at temperatures indicating groundwater contribution (temperatures  $\leq 20$  °C in the summer), interstitial flow through the channel substrates is indicated.

**Moist Channel, Isolated Pools, No Flow:** moist substrate and/or water present in isolated pools, but no visual evidence that the water in the pools is flowing.

**Dry Channel, No Water:** a completely dry channel for the entire 200 ft (61 m) stream reach. No pools, moist substrates or interstitial flow present.

Record the appropriate flow condition at the time of evaluation in the space provided on the PHWH Form. This information can be very useful in making a final use designation decision. If it is believed that low flow conditions would be significantly different than that observed at the time of the evaluation, this can be confirmed by either waiting until the stream is at seasonal low flow conditions, or by conducting a biological evaluation of the stream.

**The user must note that temporal and seasonal variations in the flow condition of PHWH streams are common and should be expected. Ephemeral conditions noted during an evaluation should be verified as typical (not drought related) based upon an analysis of the flow condition at nearby USGS stream gaging stations to ensure that the regional flow is not below the 7Q10 flow for these stations. If the flow at nearby gage stations is below the published 7Q10, the results of the PHWH evaluation should not be relied upon to assign the class of PHWH, establish the existing use of the stream in question or to recommend the aquatic life use designation.**

## 5.7 Sinuosity

**SINUOSITY** (Number of bends per 61 m (200 ft) of channel) (Check *ONLY* one box):

<input type="checkbox"/> None	<input type="checkbox"/> 1.0	<input type="checkbox"/> 2.0	<input type="checkbox"/> 3.0
<input type="checkbox"/> 0.5	<input type="checkbox"/> 1.5	<input type="checkbox"/> 2.5	<input type="checkbox"/> >3

Although not determined to be a significant discriminator of PWH stream types, the sinuosity of a stream may be related to channel modification, which is one of the primary factors used in the HHEI assessment flow chart to assign a final use designation (Figure 15). Determine the number of complete and well-defined outside bends in the 200 ft (61 m) stream reach and record on the PWH Form (Figure 16). Incomplete bends not fully included in the evaluation reach should be counted as half bends at the discretion of the observer. Indicators that can be helpful to determine the sinuosity pattern in the field are steep and eroded banks on outside bends and the presence of point bars on the inside of the bend. For recovering and recovered channels (stream modification category – Section 5.2), sinuosity of the wetted channel and thalweg may form before the stream banks have fully adjusted laterally and vertically following a disturbance of the stream channel. The user may wish to document this forming stream pattern as sinuosity on the form, using caution and noting this alternative interpretation.

The method of estimating sinuosity presented in this manual differs from the more quantitative stream geomorphology technique described in Rosgen (1996), which is based on the ratio of the channel length to valley length to define a unit-less sinuosity coefficient (K).

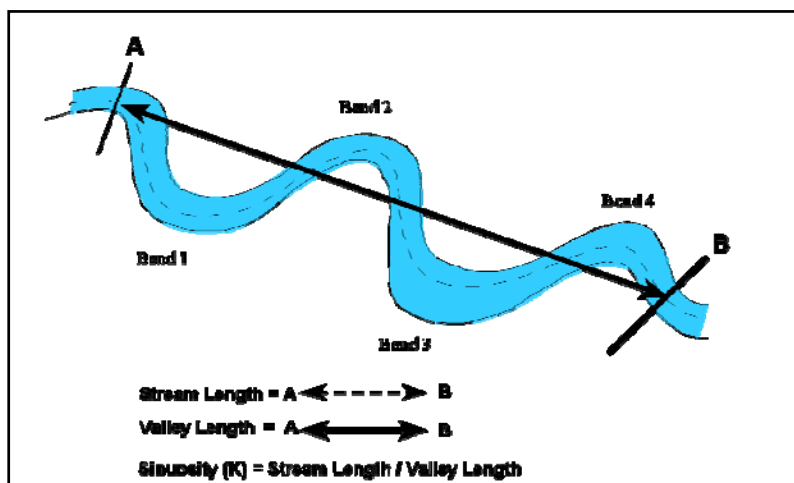

**Figure 16.** Diagram indicating the method for determining sinuosity as recorded on the PWH form. Note that points “A” and “B” represent the limits of the 200 ft (61 m) PWH evaluation reach. This particular example has four complete bends and would be entered as “>3” on the PWH form.

## 5.8 Stream Gradient

**STREAM GRADIENT ESTIMATE**  
 Flat (0.5 ft/100 ft)     Flat to Moderate     Moderate (2 ft/100 ft)     Moderate to Severe     Severe (10 ft/100 ft)

Stream gradient was not determined to be a significant overall discriminator of PHWH stream class. However, stream gradient was found to be suitable for separating Class III-PHWH streams from all other types. In general, Class III-PHWH streams tend to have moderate gradient (about 0.02 feet/foot) and rarely greater than 0.10 feet/foot drop. Both very high gradient streams and sluggish streams do not provide optimal flow hydrology for the types of biological communities adapted for life in Class III-PHWH streams. On the front of the PHWH Form, check the box with the best visual estimate of stream gradient for the stream reach.

Although several methods are available to accurately measure stream gradient using surveying techniques, these methods often require the use of expensive equipment. An excellent visual estimation method to accurately estimate the gradient without the need for specialized equipment is as follows:

- 1) stand at the mid-point of the 200 ft (61 m) evaluation zone look upstream at the marker indicating the upstream limit of the zone,
- 2) estimate the height (in feet) at which a level line extending from the upstream marker would be at the mid-point of the zone,
- 3) this height gives the gradient of the stream equivalent to the units provided on the PHWH form (ft/100 ft).

If the stream gradient is markedly different between the upstream and downstream halves of the zone, the same procedure can be repeated by observing from the downstream limit of the zone and looking upstream to the mid-point of the zone. In this case, record the average of the readings or check both boxes and provide explanatory notes on the form regarding the differences within the evaluated reach.

## 5.9

# PHWH FORM - PAGE 2

### 5.9.1 QHEI Assessment

Check the appropriate box as to whether or not a QHEI evaluation was performed. If yes, attach a copy of the final QHEI sheet. See [Section 3.3](#) for a discussion regarding how to determine whether a QHEI assessment is necessary when categorizing a suspected PHWH stream.

### 5.9.2 Downstream Designated Uses(s)

If known, mark the box which indicates the appropriate downstream designated uses (within two river miles). Check a box only if the stream segment feeds to a wetland or to a stream with a known use designation. If the downstream segments are un-designated, check no boxes, but describe downstream characteristics in the space provided.

Please be specific in responses to this item! Information provided in this section can be used to evaluate potential beneficial uses of the water body and to evaluate potential impacts on downstream uses. A description of the drainage hierarchy downstream of the segment being analyzed to the nearest named stream should be provided if possible.

### 5.9.3 Location Information

Attach a copy of both the USGS topographic map and the NRCS county soil map with the watershed areas of the PHWH streams clearly identified. Enter information regarding the maps on which the evaluated reach lies on the PHWH form in the spaces provided. Also identify the county and township or municipality where the site is located.

### 5.9.4 Miscellaneous

Several items on page 2 of the PHWH form are provided for entering miscellaneous information about the evaluated stream reach and its condition on the day the survey. They include:

- A space to indicate whether or not the stream was at base flow conditions for the season of the year when the field evaluation was conducted. Two additional pieces of information are recorded in this portion of the form that can be helpful in making this determination, the date and quantity of the last local precipitation (if known) and whether or not the turbidity of the water is elevated on the day of the site visit. If

there has been significant rainfall or snow melt within the previous 48 hours and the turbidity of the stream is high, the PHWH evaluation should be postponed until the stream returns to base flow conditions.

- A space is provided to record an estimate of the percent openness of the overhanging tree canopy over the stream reach. The amount of open area in the tree canopy should be estimated as that which would be experienced at the time of maximum leaf cover. In most situations, a visual estimate of the percent openness of the canopy is sufficient, although quantitative estimates can be obtained through the use of a leaf densiometer. Information regarding the amount of shading of the stream can be useful for making a final determination of the appropriate use designation for the PHWH stream under investigation.
- Spaces are provided to record field measurements for dissolved oxygen, pH, water temperature, and conductivity using standard Ohio EPA quality control methods (Ohio EPA, 2006 b). If no field monitoring equipment is available, at a minimum, the water temperature of the stream (if water is present) should be recorded during each PHWH assessment. Temperature in summer months can be used to verify potential cool-cold water Class III-PHWH streams. In general, Class III-PHWH streams will have daily average summer water temperature below 20° C, with values less than 18° C near the spring source. Water in Class III-PHWH streams can have daily maximum summer water temperature higher than 20° C well downstream from their spring source(s), but average daily temperatures will rarely be above 23° C (see Ohio EPA 2002 b).
- A space is provided to record whether water samples were collected for laboratory analyses. Water samples for analyses in addition to the field parameters listed above do not need to be collected routinely in order to classify PHWH streams. However, in the event that upstream chemical pollution of the water is suspected, a sample should be collected for analysis in order to ensure that site biology is not affected by water chemistry. If a sample is collected, provide the sample identification information and provide copies of the analytical report. Under these circumstances, analyses should be conducted for nutrient parameters (ammonia-N, nitrate+nitrite-N, total phosphorus), COD, chlorides, heavy metals, and *E. coli* bacteria. Where acid mine drainage is suspected include samples for iron, manganese, and sulfates. The Water Quality Standards found in OAC Chapter 3745-1 should be consulted in order to determine if any applicable standards are exceeded. Appropriate comparisons for Class I and Class II PHWH streams are the standards applicable to WWH streams, while the standards for CWH streams should be used to evaluate water quality data from Class III PHWH streams.

### **5.9.5 Biological Evaluation Summary**

If a biological evaluation is conducted, complete the information in this section of the form as indicated. A detailed summary of biological data should be recorded on pages 3 and 4 of the PHWH Form (see [Section 6.0](#)).

### **5.9.6 Drawing and Narrative Description of the PHWH Stream Reach**

In the space provided on the form, make a drawing of the evaluated PHWH stream reach. Include important landmarks, habitat features, information regarding substrate distribution, the locations for the measurement of bankfull widths, pools and pool depths, riffles, and any other features of interest. Also include information regarding any road crossings or points for access. The drawing should include comments on the type of riparian zone and land use adjacent to the stream reach, and any observations regarding seepage areas. The stream drawing is a critical component of the assessment process and is extremely useful to document the condition of the evaluated reach on the day of the site evaluation. **The PHWH evaluation process should not be deemed to be complete unless the stream drawing is completed.**

## PHWH FORM - PAGES 3 & 4

### 6.0 Biological Sampling

All data collected for biological assessments should be recorded on pages 3 and 4 of the PHWH Form. The following sections provide information on the standardized methods to be used to collect and preserve biological specimens.

#### 6.1 Headwater Fish

Many primary PHWH streams less than 1.0 mi<sup>2</sup> (259 ha) contain fish species that are classified by Ohio EPA (1989) into one of three major categories: (1) cold water adapted (e.g., Redside Dace); (2) pioneering (e.g., Creek Chub), or (3) headwater adapted (e.g., Blacknose Dace). All three types of headwater fish species have been collected in PHWH streams less than 1.0 mi<sup>2</sup>. A list of all species of fish collected from PHWH streams by Ohio EPA in 1999 and 2000 is provided in Table 4. The Creek Chub was the most common species, collected in 32.8% of all samples, with Bluntnose Minnow (19.4 %), and Blacknose Dace (10.4 %) next in frequency of occurrence (see also Ohio EPA, 2002 c).

Although many different species of fish are present in PHWH streams as shown in Table 3, it becomes increasingly less likely that a well balanced fish community, as measured by the Index of Biotic Integrity, can be supported as watershed size falls below 1.0 mi<sup>2</sup> (259 ha). Fish are more likely to move out of PHWH streams because of the lack of refugia during low and zero flow conditions. The lack of permanent nursery areas for young of the year fish also precludes the establishment of well balanced fish communities. There often exists in natural watersheds a lower limit in watershed size and stream scale where fish are no longer observed, but are replaced by amphibious salamanders (see [Figure 1](#)). The presence of cool-cold water fish species from Table 3 can be used to identify the presence of a Class III PHWH stream. A Class II-PHWH stream may be indicated by the presence of warmwater adapted populations of fish in the absence of any other Class III indicator taxa.

Sampling methods to collect fish in PHWH streams can include electro-fishing techniques (i.e., long-line or backpack methods), use of a 10 ft seine, or collection with a fine mesh benthic invertebrate net. If assessing the stream for potential WWH, CWH, or EWH use designations, standard procedures using electro-fishing techniques must be followed (Ohio EPA, 1989).

**Table 4.** Fish species observed/collected in Primary Headwater Habitat streams in Ohio, 1999-2000. Fish were captured in 67 of the streams sampled. Fish species in **bold** represent PHWH stream indicator species based upon habitat preference. Species listed in *italics* indicate cold water adapted Class III indicator species. Yes indicates that the species is associated with the listed ecological category by Ohio EPA (Ohio EPA, 1989); No indicates that the species is not associated with that category.

Species (common name)	Percent Occurrence	Pioneering Species	IBI-Headwater Species	Coldwater Species
<b>Creek Chub</b>	32.8	Yes	---	---
<b>Bluntnose Minnow</b>	19.4	Yes	---	---
<b>Blacknose Dace</b>	10.4	---	Yes	---
Rainbow Darter	7.5	---	---	---
Bluegill Sunfish	4.5	---	---	---
<b>Johnny Darter</b>	4.5	Yes	---	---
Stoneroller Minnow	4.5	---	---	---
Largemouth Bass	2.9	---	---	---
<b>Fantail Darter</b>	2.9	---	Yes	---
Greenside Darter	2.9	---	---	---
White Sucker	2.9	---	---	---
<b>Green Sunfish</b>	2.9	Yes	---	---
<i>Redside Dace</i>	1.5	---	Yes	Yes
<i>Mottled Sculpin</i>	1.5	---	Yes	Yes
<i>Brook Trout (native)</i>	1.5	---	---	Yes
Rainbow Trout**	1.5	---	---	Yes
Goldfish**	1.5	---	---	---
Mudminnow	1.5	---	---	---
<b>Orangethroat Darter</b>	1.5	Yes	---	---

**Fish Species expected to occur in PHWH streams in Ohio but not observed during 1999 and 2000 surveys**

<b>Creek Chubsucker</b>	-	Yes	---	---
<b>Southern Redbelly Dace</b>	-	---	Yes	---
<b>Rosyside Dace</b>	-	---	Yes	---
<b>Silverjaw Minnow</b>	-	Yes	---	---
<b>Fathead Minnow</b>	-	Yes	---	---
<i>Brook Stickleback</i>	-	---	Yes	Yes
Brown Trout**	-	---	---	Yes

\*\* Non-Native to Ohio



For a PHWH stream survey, fish must be collected for at least 15 minutes through the 200 ft (61 m) stream reach under investigation. Record all species collected and their total numbers on the HHEI field form. Voucher specimens should be collected for each species and preserved in a solution consisting of one part buffered formalin and nine parts water. If voucher specimens are to be held longer than 2-3 weeks, the specimens should be transferred to a 70% ETOH preservative solution using the methods described in the Ohio EPA methods manual (Ohio EPA, 1989). Place a field tag in/on the jar which includes date, collector name, county, township, and stream identification as listed on the HHEI field evaluation form. Record in minutes the total time spent searching for fish. If there are deep pools present that are greater than 40 cm maximum depth, then the Ohio EPA QHEI habitat evaluation should be conducted, and the stream evaluated for potential to attain the Ohio EPA Warmwater Habitat (WWH) or Exceptional Warmwater Habitat use designations according to established agency procedures (Rankin, 1989). The presence of cold water adapted fish may trigger the Coldwater Habitat (CWH) designation.

## 6.2 Headwater Salamanders

In the headwaters of watersheds, aquatic to semi-aquatic salamander species replace fish as the primary vertebrate predator functional group (Figure 1). These amphibians are distributed throughout Ohio except for the counties in the northwest area of the state. Detailed maps for the distribution of salamanders in Ohio by county are given in Pfingsten and Downs (1989), Pfingsten (1998), and Pfingsten and Matson (2003). Because salamanders are most active during the night in response to predation by other vertebrates, they are found during the daylight hours hiding under different types of microhabitat cover including rocks, logs, leaves, moss, bark, burrows, etc. Thus any attempt to collect salamanders along a stream corridor must include an effort to sample all the different types of microhabitat cover available in the stream reach under investigation.

Based on the results of the 1999 and 2000 sampling, three assemblages of salamander species have been identified from PHWH streams throughout the state, which are summarized in Table 5, and discussed in detail below:

**Class III-PHWH Salamander Assemblage** (perennial flow cool water adapted; larvae present in stream on annual basis, usually with greater than 12 month larval period)

This salamander assemblage is represented by species of obligate aquatic species that have larvae resident in the stream channel on an annual basis. Most of these species have larval stages that last for at least two years based on available literature, with a maximum span between 4-5 years (Petranka, 1998; Pfingsten and Downs, 1989). The exception is the Longtail Salamander, *Eurycea longicauda*, which may or may not have a larval period greater than 12 months in Ohio. These species also require flowing

**Table 5.** Species of salamanders that can be used as bio-indicators of Class III (cool-cold water, perennial flow) and Class II (warmwater, intermittent flow) PHWH streams in Ohio.

---

**Species adapted to Perennial Flow, with Larval Periods > 12 Months (Class III-PHWH Indicators)**

---

Family Plethodontidae (Lungless Salamanders)

Subfamily Plethodontinae; Tribe Hemidactyliini

*Eurycea bislineata* (Northern Two-Lined Salamander)

*Eurycea cirrigera* (Southern Two-Lined Salamander)

*Eurycea longicauda* (Long-Tailed Salamander) [Some populations may have short larval periods.]

*Eurycea lucifuga* (Cave Salamander)\*\*

*Gyrinophilus porphyriticus porphyriticus* (Northern Spring Salamander)

*Gyrinophilus porphyriticus duryi* (Kentucky Spring Salamander)

*Pseudotriton montanus diasticus* (Midland Mud Salamander)\*\*

*Pseudotriton ruber ruber* (Northern Red Salamander)

---

**Species Adapted to Survive Intermittent Flow, with Larval Periods < 12 months (Class II-PHWH Indicators)**

---

Family Ambystomatidae (Mole Salamanders)

*Ambystoma barbouri* (Streamside Salamander)

Other *Ambystoma spp.* (Such as Smallmouth Salamander, Tiger Salamander)

Family Plethodontidae (Lungless Salamanders)

Subfamily Desmognathinae

*Desmognathus fuscus* (Northern Dusky Salamander)

*Desmognathus ochrophaeus* (Allegheny Mountain Dusky Salamander)

Subfamily Plethodontinae; Tribe Hemidactyliini

*Hemidactylium scutatum* (Four-Toed Salamander)\*\* [This species not common in headwater streams.]

---

\*\* Note: The salamander species, *Eurycea lucifuga* (Cave Salamander), *Ambystoma laterale* (Blue-Spotted Salamander), and *Aneides aeneus* (Green Salamander) are listed as "endangered" species in Ohio (ORC 1531:25). The species *Pseudotriton montanus diasticus* (Midland Mud Salamander) is listed as a "threatened" species and *Hemidactylium scutatum* (Four-Toed Salamander) is listed as a species of "special concern" in ORC 1531:25.

Adapted from "Salamanders of the United States and Canada", 1998. James W. Petranka.  
Smithsonian Institution Press, Washington, DC.

water for egg deposition, with females usually laying eggs in habitats saturated with flowing water. Salamander species associated with Class III-PHWH streams in Ohio are taxonomically related, all classified within the Tribe Hemidactyliini, Subfamily Plethodontinae, of the Family Plethodontidae. Eight species or subspecies from the genera *Eurycea*, *Gyrinophilus*, and *Pseudotriton* are recognized for Ohio (Table 6). Two of these species, the Cave Salamander (*Eurycea lucifuga*), and the Midland Mud Salamander (*Pseudotriton montanus diasticus*) are listed as endangered and threatened, respectively, in ORC 1531.25. The most common species collected during the 1999 and 2000 survey were the Northern Two-Lined salamander (*Eurycea bislineata*) and the Southern Two-Lined Salamander (*Eurycea cirrigera*). Their presence in PHWH streams is highly associated with the presence of cool water adapted species of benthic macroinvertebrates.

**Class II-PHWH Salamander Assemblage** (intermittent flow warm water adapted; larvae present in the stream seasonally, less than 12 month larval period)

The second assemblage of salamanders found in PHWH streams in Ohio are associated with a continuum of permanent to intermittent flow conditions, and are distinguished from the obligate aquatic assemblage of salamanders by having a larval period less than 12 months. These non-obligate aquatic salamander species are taxonomically different from the obligate salamander assemblage, being classified within the Subfamily Desmognathinae of the Family Plethodontidae, the Family Ambystomatidae, and the rarely encountered species *Hemidactylium scutatum* (Four-Toed Salamander). Although salamanders from this non-obligate group may be found coexisting with obligate Class III salamander species, these non-obligate aquatic species have life history traits that do not require residence in flowing water on an annual basis. Salamanders in Ohio from the genus *Desmognathus* do not require flowing water for egg clutch deposition, but instead lay eggs in streambank habitats, usually under rocks, moss, or logs; although seepage areas may also be utilized. Species from the genus *Ambystoma*, which may lay eggs within the flowing water of a PHWH stream channel, have short larval periods. They tend to be found in streams that become intermittent or completely dry during summer months. A third aquatic salamander genus, *Hemidactylium*, is largely found in sphagnum bogs, but may migrate to headwater streams that connect to these bogs. The presence of species of salamanders from this non-obligate aquatic assemblage can be used to identify the presence of a warmwater Class II-PHWH stream types. Two species from this second group, the Blue-Spotted Salamander (*Ambystoma laterale*) and the Four-Toed Salamander (*Hemidactylium scutatum*), are listed as endangered and special concern, respectively, in ORC 1531:25.

**Class I-PHWH Salamander assemblage** (adapted for life in terrestrial forest habitat, no aquatic larvae stage of development, may forage in dry channels in search of food).

A third assemblage of salamander species that may on occasion migrate into small PHWH stream corridors, usually during wet periods, include species from the genera *Plethodon*. These salamander species have terrestrial modes of existence and lack larval stages, but they are an important component of the food web structure of second growth forests in Ohio. *Plethodon* species are good bio-indicators of various stages of forest succession, with preference for old growth forest seral stages. They are common in Beech-Maple associations that once were dominant throughout Ohio. *Plethodon* salamanders live in burrows and under decaying logs and leaf litter in forested areas throughout the state. They may forage in dry Class I PHWH stream channels in search of food.

### 6.2.1 Salamander Sampling Effort

The goal of the PHWH stream salamander evaluation is to document the presence-absence of species from the three major ecological groups discussed above. The technique used is a modification of a Visual Encounter Survey (VES) as described by Heyer, et al. (1994). Although a VES survey is semi-quantitative, more vigorous sampling techniques can be utilized to quantify salamander densities if required. Examples include the 4 m<sup>2</sup> quantitative sampling method as described by Rocco and Brooks (2000), or the placement of artificial substrates such as flat boards or leaf bags. These types of quantitative estimates of salamander abundance have not been calibrated for this PHWH manual.

Begin the salamander Visual Encounter Survey (VES) by selecting **TWO** 30 ft (9.1 m) sections of stream within the 200 ft (61 m) stream reach under investigation. Choose each sample zone where an optimal number and size of cobble type microhabitat substrate is present (64 to 128 mm length), even over bedrock. This substrate size class has been shown to be a good predictor of the presence of obligate aquatic salamander species. If both salamander and benthic invertebrate sampling is to be conducted at the same time by two people, place the salamander sample zones upstream from the initial macroinvertebrate survey to eliminate problems with water turbidity caused by kick net sampling. If no salamanders are observed in the first 30 ft (9.1 m) sample zone, repeat the process for the second zone.

An ordinary metal strainer, bent to a triangular shape, or a fine mesh aquatic invertebrate net is recommended for the collection of salamanders, especially the small slippery and elusive larvae. Flat edge insect nets can also be used. Due to high oxygen demand, gilled, pre-metamorphic larvae are restricted to the flowing water of the stream. They are often found hiding under cover objects such as rocks, leaves, and woody material as a protection from possible predators.

As the collection effort moves upstream, first place the net against the bottom substrate and then lift cover objects in front of the net. To capture larval salamanders, position the net in front of the salamander's head, and gently touch the tail; more often than not

they will move forward into the net. Replace cover objects that are lifted to their original position to minimize habitat disturbance. Another technique used to capture salamander larvae is to attach a 200 ml suction bulb to a small rubber tube of sufficient diameter to allow salamander larvae to enter. Place the tube near the larvae and use the suction bulb to capture the larvae in the tube. This method is useful in areas of the stream where larvae are hiding in such a way that nets or strainers will not work. A high intensity head light may be helpful in some headwater streams due to low light conditions under tree canopy.

Spring Salamanders (*Gyrinophilus spp.*) are often found at the terminal limits of a PHWH stream, near the ground water source. These salamanders are known to bury into gravel substrate as adults, although larvae can be located under rocks throughout the stream channel. When searching for salamanders near a ground water source, extra time should be spent digging into any gravel substrate that may be present.

All captured salamanders should be placed into a plastic container or zip-loc bag (double) so that species can be identified and the total number of each type counted. Take note of any salamanders that escape capture and include those in the total tally for the 30 ft (9.1 m) sample zone. At least 3 ft (about 1 m) on each side of the wet portion of the stream channel should also be searched for juvenile and adult salamanders. These age classes often migrate away from the water in search of food or places to hide from predators.

Place all captured salamanders into a white tray with a small amount of water. Gills on the head of the larvae will be visible against the white background to allow them to be identified. Record the total number of each salamander species collected on page 3 of the PHWH Form. Include in the tally the total number of salamanders observed but that escaped capture. After voucher specimens are taken, replace all remaining salamanders into stream section from which they were collected.

The goal of the PHWH stream sampling effort for salamanders is to document the presence or absence of different species of salamanders. Therefore, all available micro habitats for salamanders should be searched. At least 30 minutes should be spent searching for salamanders, and the entire 30 ft (9.1 m) zone should be surveyed during the survey. Emphasis should be placed on the collection of salamander larvae since this age class is the best predictor that the salamander population is resident in the stream on an annual basis. However, a mixture of juvenile and mature salamanders at a site also indicates that a population is using the stream channel for reproduction.

Within each 30 ft (9.1 m) sample zone, salamander abundance can be estimated using the Visual Encounter Survey (VES) technique as described by Heyer et al. (1994). Time is expressed as the number of person-hours of searching within the 30 ft (9.1 m) zone. Record the exact amount of time expended in searching for salamanders to the minute on the PHWH Form. A Visual Encounter Survey can be used to determine the

salamander species richness of a stream segment, and to estimate the relative abundances of species on a time basis. Because turbidity can greatly affect the results of a VES, monitoring should only be conducted when water is clear. Extra care must be taken if the sampling occurs during leaf fall in September through November of the year as the leaves will make searching more difficult.

### **6.2.2 Salamander Voucher Specimens**

Collect voucher specimens and transport them live to the laboratory for proper preservation. Place captured salamanders into double plastic bags (or plastic containers with air holes) with some moist leaf litter or moss. Use a cooler with block ice for transport to the lab for preparation of scientific voucher specimens. At least five larvae and two juvenile-adults should be preserved for each species type observed in the field, if possible.

At the lab, salamanders should be killed as quickly and humanely as possible in a way that leaves them in a relaxed position. Salamanders may be killed by drowning in a weak ETOH (15%-20%) solution. It may be necessary to straighten the organism several times prior to death in order to ensure that they are not fixed in a curled position. Once dead, the specimen is fixed by placing in a tray lined with white paper towel soaked with 10% formalin. The individual should be laid out straight with the limbs pointing forward parallel to the body. The toes should be spread with the palmar surface facing down. Cover with a second paper towel and add 10% formalin to the tray to a depth of 1 cm. Cover the tray to stop formalin odors. The salamanders should harden somewhat within 2 hours. Specimens should then be transferred to a jar of 10% formalin for shipment or short term storage. Place a field tag in/on the jar which includes date, collector name, county, township, and stream identification as listed on the field evaluation form (see [Attachment 5](#) to this manual). For long term storage, run the formalin preserved salamanders through a series of first distilled water, then 15% ETOH, 30% ETOH, and finally 70% ETOH. Salamanders should stay in each solution for 24 hours.

**Table 6.** List of salamander species in Ohio that use primary headwater stream corridors as a habitat for egg deposition (oviposition) and larval growth. Species ordered from shortest length of larval period to longest. Life history data from personal observations of R.D. Davic (Ohio EPA), Harding (1997), Pflingsten and Downs (1989), Petranka (1998), Hulse et al. (2001). *Plethodon* and *Aneides* species with direct development not included in the table. When multiple species are collected in the same stream segment, the species with the highest numerical classification is used to indicate potential appropriate PHWH stream class (I, II, or III). **Only evidence of reproduction (larvae, eggs, or mixture of juveniles and adults) can be used to determine stream class.** Table by R. D. Davic, Ohio EPA.

Species	Micro-habitat and Season for Egg Clutch Deposition	Length/Season of Larval Period
	<u>PHWH Stream Class Indicator</u>	
Four-Toed Salamander <i>(Hemidactylium scutatum)</i>	Found in bog habitats, eggs usually found in moss (sphagnum) from March to May. Eggs may be found in slow moving headwater streams associated with bog habitat. Adults terrestrial. <b><u>If evidence of reproduction found, a Class-II PHWH stream indicator species.</u></b> Protected as a Special Interest species in ORC, Section 1531.25.	1-2 months (May to June)  Pond type larval
Streamside Salamander <i>(Ambystoma barbouri)</i>	SW Ohio only. Oviposition from January to March in headwater streams with few fish. Stream usually becomes intermittent during summer. Often in limestone type geology. Eggs found in water under rocks from December to March. <b><u>If evidence of reproduction found, a Class II-PHWH stream indicator species.</u></b>	2-3 months (March to May)
Allegheny Mountain Dusky Salamander <i>(Desmognathus ochrophaeus)</i>	Extreme NE Ohio only. Oviposition near seepage areas, mostly from August to October. Known to breed in sub-surface habitats. Stream may become intermittent in summer. Adults will forage in riparian areas. <b><u>If evidence of reproduction found, a Class II-PHWH stream indicator species.</u></b>	1-3 months. Most common in September to November, but may occur in March-April in some Ohio populations.
Northern Longtail Salamander <i>(Eurycea longicauda)</i>	Statewide except northwest and north-central Ohio. Oviposition over winter in streams and seepage areas associated with rock outcrops or in sub-surface areas. Often in limestone or shale geology, around caves. <b><u>If evidence of reproduction found, a Class II-PHWH stream indicator species. If two larval age classes present, then a Class III indicator.</u></b>	4-5 months, (March to July) but may extend to 12-14 months in local populations. Larval period not well known for Ohio.

**Table 6 (cont.).** List of salamander species in Ohio that use primary headwater stream corridors as a habitat for egg deposition (oviposition) and larval growth. Species ordered from shortest length of larval period to longest. Life history data from personal observations of R.D. Davic (Ohio EPA), Harding (1997), Pfungsten and Downs (1989), Petranka (1998), Hulse et al. (2001). *Plethodon* and *Aneides* species with direct development not included in the table. When multiple species are collected in the same stream segment, the species with the highest numerical classification is used to indicate potential appropriate PHWH stream class (I, II, or III). **Only evidence of reproduction (larvae, eggs, or mixture of juveniles and adults) can be used to determine stream class.** Table by R. D. Davic, Ohio EPA.

Species	Micro-habitat and Season for Egg Clutch Deposition	Length/Season of Larval Period
	<u>PHWH Stream Class Indicator</u>	
Northern Dusky Salamander ( <i>Desmognathus fuscus</i> )	Statewide except northwest and north-central Ohio. Oviposition in streambank microhabitats or seepage areas, outside flowing water (June to August). Eggs not in flowing water, but located streamside under rocks, logs, moss with brooding female. <b><u>If evidence of reproduction found, a Class II- PHWH stream indicator species.</u></b> May be found in Class III stream habitats.	9-10 months (September to May) No larvae in late June-early August. Young and old larvae may be found along streambanks outside of flowing water.
Cave Salamander ( <i>Eurycea lucifuga</i> )	Extreme southwest counties of Ohio, at northern edge of geographic range. Oviposition from September to February within caves. <b><u>If evidence of reproduction found, a Class III-PHWH stream indicator species.</u></b> Very rare, classified as an Endangered Species in Ohio (ORC 1531.25).	Mostly 14-18 months with two larval age classes common in Indiana populations. Larval period not well known for Ohio.
Midland Mud Salamander ( <i>Pseudotriton montanus diasticus</i> )	Extreme south-central Ohio. Oviposition in autumn, embryos hatch in winter. Common in burrows; egg nests in cryptic underground sites. <b><u>If evidence of reproduction found a Class III PHWH stream indicator species.</u></b>	15 to 30 months, larval period not well known for Ohio populations.
Northern Two-Lined Salamander ( <i>Eurycea bislineata</i> )	North Central to North East Ohio. Common in perennial flowing PHWH streams. Oviposition from April to May, in shallow running water under flat rocks. May be found in dry streams with interstitial sub-surface flow. <b><u>If evidence of reproduction found, a Class III PHWH stream indicator species.</u></b> Known to migrate into higher order streams.	24 to 36 months in Ohio. Three distinct larval age classes observed in some populations.



**Table 6 (cont.).** List of salamander species in Ohio that use primary headwater stream corridors as a habitat for egg deposition (oviposition) and larval growth. Species ordered from shortest length of larval period to longest. Life history data from personal observations of R.D. Davic (Ohio EPA), Harding (1997), Pfungsten and Downs (1989), Petranka (1998), Hulse et al. (2001). *Plethodon* and *Aneides* species with direct development not included in the table. When multiple species are collected in the same stream segment, the species with the highest numerical classification is used to indicate potential appropriate PHWH stream class (I, II, or III). **Only evidence of reproduction ( larvae, eggs, or mixture of juveniles and adults) can be used to determine stream class.** Table by R. D. Davic, Ohio EPA.

Species	Micro-habitat and Season for Egg Clutch Deposition	Length/Season of Larval Period
	<u>PHWH Stream Class Indicator</u>	
Southern Two-Lined Salamander <i>(Eurycea cirrigera)</i>	Southern portion of Ohio, considered a sub-species of <i>E. bislineata</i> by Petranka (1998). Same behavior as northern two-lined salamander. <b><u>If evidence of reproduction found, a Class III-PHWH stream indicator species.</u></b>	24 to 36 months in Ohio. Three distinct larval age classes in summer.
Red Salamander <i>(Pseudotriton ruber)</i>	Eastern portions of state, north to south. Oviposition from October to February, usually in sub-surface areas. Adults migrate away from streams in spring-summer, but overwinter in headwater springs. Associated with sandstone geology. <b><u>If evidence of reproduction found, a Class III-PHWH stream indicator species.</u></b>	24 to 36 months, may overwinter to a fourth year as larvae.
Spring Salamander complex <i>(Gyrinophilus p. porphyriticus, and G. p. duryi)</i>	East to east-central and southern portions of the state. Oviposition in summer months, in sub-surface areas. Adults may forage away from streams. This species has a propensity for a subterranean mode of life in cold-cool headwater springs. May be associated with caves. <b><u>If evidence of reproduction found, a Class III-PHWH stream indicator species.</u></b>	36 to > 48 months.

### **6.3 Headwater Benthic Macroinvertebrates**

Benthic macroinvertebrates are to be collected by searching representatives of all available habitat types within the 200 ft (61 m) stream reach segment. The collection techniques must follow the standard qualitative macroinvertebrate collection techniques used by Ohio EPA (Ohio EPA, 1989, Ohio EPA, 2008 b). All potential habitats (riffles, runs, pools, and along stream margins) should be searched for macroinvertebrates. Visually scan the stream bottom for organisms and their retreats. Pick up and examine numerous larger substrates such as rocks, woody debris, and leaf packs. Place a small net (about 10 inches wide with a curved or flexible rim) with small mesh size downstream from substrates when they are disturbed to capture dislodged specimens. Wash small amounts of fine particle sized substrates through the net and examine the contents with a white enamel pan. Use a white pan to sort through the rocks and debris and to help identify and keep track of the taxa you are finding. Collect invertebrates for at least 30 minutes from all available habitats and thereafter until no new taxa are found.

Record the presence and relative abundance (i.e., rare, common, abundant) of all major taxa collected within the sampling area on Page 4 of the PHWH Form. For the mayfly, caddisfly, and stonefly groups (i.e., the EPT taxa) record the total number of different types of taxa observed for each group. This determination is typically at the Family taxonomic level and can often be made based on body shape and size. Special care must be given to searching for the very small and often cryptic chironomid (midge) larvae. Many cool-cold taxa that are associated with Class III-PHWH streams are found in this taxonomic group. Special care must also be taken during times of leaf fall because of the interference that the leaves cause in searching for organisms.

Voucher specimens of all taxa should be collected and preserved in 70 % ETOH or higher. Special effort should be made to collect specimens of all potential EPT taxa (i.e., mayflies, stoneflies, caddisflies) to allow for calculation of the Headwater Macroinvertebrate Field Evaluation Index (see [Section 6.3.1](#)). Place a field tag in the jar which includes date, collector name, county, township, and stream identification as listed on the PHWH Form.

#### **6.3.1 Headwater Macroinvertebrate Field Evaluation Index (HMFEI)**

The overall condition of the benthic macroinvertebrate community can be evaluated using a modified version of the Ohio DNR Stream Quality Monitoring scoring system for the State Scenic Rivers program (see the following web link for further information: <http://ohiodnr.com/watercraft/sgm/tabid/2550/default.aspx> . The methodology developed for PHWH streams is referred to as the Headwater Macroinvertebrate Field Evaluation Index (HMFEI). The HMFEI is a rapid bio-assessment field sampling method designed by Ohio EPA biologist Mike Bolton. The index has been documented to be a good predictor of the various classes of PHWH streams in Ohio. The HMFEI is

designed for use in the field, but does require the taxonomic expertise to distinguish taxa to the Family level in many cases. Although the HMFEI can be a useful rapid assessment tool, it is inferior to a more detailed identification of cold water adapted species of benthic macroinvertebrates as obtained through analysis of a voucher sample to the lowest practical taxonomic level back at the laboratory. Cold water indicator benthic macroinvertebrate taxa that are associated with Class III PWH streams are listed in the document *2008 Updates to Biological Criteria for the Protection of Aquatic Life: Volume II and Volume II Addendum* (Ohio EPA, 2008 c) and are provided in Attachment 3 of this document.

### **6.3.2 Using the Headwater Macroinvertebrate Field Evaluation Index (HMFEI) to Assign an Aquatic Life Use Designation to a PWH Stream.**

The HMFEI uses field level identification at the Family or Order level of taxonomy to classify different assemblages of benthic macroinvertebrates found in headwater streams. The HMFEI is designed to be calculated in the field. However, if it is calculated from a voucher sample, care should be taken that the same level of identification possible in the field is used. Field identification of the EPT taxa is usually possible only at the family level. The HMFEI is roughly based on a scoring system used by the Ohio DNR Scenic Rivers Stream Quality Monitoring system, with modifications to reflect the faunal composition found in small PWH streams. In addition to redefining the taxa belonging to the different scoring categories, the HMFEI multiplies each taxa of mayflies, stoneflies, and caddisflies that are recognizable in the field, by the score value of three.

Table 7 lists the three major groups of benthic macroinvertebrate taxa to be scored using the HMFEI evaluation. The final HMFEI is calculated by multiplying each taxa group present at the site by the appropriate scoring value, with mayflies, caddisflies, and stonefly groups for which each field-recognizable taxa belonging to these groups are multiplied by the scoring value. Use Page 4 of the PWH Form to record the information needed to calculate a final HMFEI score.

The HMFEI is reasonably good at separating Class III (cold water adapted) from Class II (warmwater adapted) benthic macroinvertebrate species groups. A HMFEI score of >19 provides separation between these two types of streams at approximately the 75<sup>th</sup> percentile level. Because the HMFEI is designed to be used with a level of taxonomy that is inferior to the identification of organisms to the lowest practical level at the laboratory, it is crucial that the biologist conducting the survey have the Family level of taxonomic expertise.

An example of a HMFEI scoring procedure is given below. In this example a 200 ft (61 m) PWH stream reach was sampled and the eight (8) major Taxa Groups (see [Table 3](#) for a list of major taxa groups) were collected. A voucher sample was collected for each of the major taxa observed as follows:

=====

<u>Taxa Group</u>	<u>Group Type:</u>	<u>Metric Scores:</u>
Turbellaria (aquatic worm)	1	1
Mayflies: 2 taxa	3	2 x 3 = 6
Corydalidae (fishfly)	3	3 x 1 = 3
Caddisflies: 3 taxa	3	3 x 3 = 9
Tipulidae	3	3
Blackflies (other diptera)	1	1
Midges	1	1
Snails	1	1
<b>Total HMFEI Score</b>		<b>25</b>

Based on a final HMFEI score of 25, the stream reach described above has a benthic macroinvertebrate assemblage associated with vertebrates found in a Class III-PHWH stream.

The HMFEI can be conducted any time of the year. However, for the most representative results it is suggested that it be conducted during the summer (June to September) in order to avoid the taxa increase during the spring time (January to May) and the sampling difficulty associated with leaf fall in the fall (October to December).

The following guidelines are to be used with the HMFEI evaluation to make a decision on the appropriate aquatic life use designation to give to the undesignated PHWH stream:

IF Final HMFEI Score is > 19, Then <b>CLASS III</b> PHWH STREAM
IF Final HMFEI Score is 7 to 19, Then <b>CLASS II</b> PHWH STREAM
IF Final HMFEI Score is < 7, Then <b>CLASS I</b> PHWH STREAM

A more detailed identification of the macroinvertebrate voucher sample could also be conducted to determine if four or more cold water macroinvertebrate taxa are present as listed in Attachment 3.

**Table 7.** Headwater Macroinvertebrate Field Evaluation Index (HMFEI) scoring categories for use in assessing primary headwater habitat streams in Ohio.

<b>Group 1 Taxa (Scoring Value = 1)</b>	<b>Group 2 Taxa (Scoring Value = 2)</b>	<b>Group 3 Taxa (Scoring Value = 3)</b>
Sessile Animals (Porifera, Cnidaria, Bryozoa)	Crayfish (Decapoda)	Mayfly Nymphs <sup>1</sup> (Ephemeroptera)
Aquatic Worms (Turbellaria, Oligochaeta, Hirudinea)	Dragonfly Nymphs (Anisoptera)	Stonefly Nymphs <sup>1</sup> (Plecoptera)
Sow Bugs (Isopoda)	Riffle Beetles (Dryopidae, Elmidae, Ptilodactylidae)	Caddisfly Larvae <sup>1</sup> (Trichoptera)
Scuds (Amphipoda)		Fishfly Larvae (Corydalidae)
Water Mites (Hydracarina)		Water Penny Beetles (Psephenidae)
Damselfly Nymphs (Zygoptera)		Cranefly Larvae (Tipulidae)
Alderfly Larvae (Sialidae)		
Other Beetles (Coleoptera)		
Midges (Chironomidae)		
Larvae of Other Flies (Diptera)		
Snails (Gastropoda)		
Clams (Bivalvia)		

Note: Hemiptera (True Bugs) do not receive any points in the HMFEI.

<sup>1</sup> Note: each identified taxon of the Ephemeroptera, Plecoptera, and Trichoptera (EPT taxa) receives three points under the HMFEI scoring system.

## 7.0 Using a Biological Assessment to Assign an Aquatic Life Use Designation

The following criteria must be followed to assign an appropriate PHWH classification to a stream based on assessment of biological communities:

---

### **Determination of a Class III-PHWH stream (cold water adapted community)**

---

A Class III-PHWH stream can be identified by the presence of cold water adapted species of fish (Table 4) **and/or** by the presence of reproducing populations of one of the eight species (subspecies) of obligate aquatic salamander species from the genera *Eurycea*, *Pseudotriton*, or *Gyrinophilus* as listed in Tables 5 and 6.

A Class III-PHWH stream can also be identified by a detailed taxonomic evaluation of the benthic macroinvertebrate community using the cold water species list found in Attachment 3. The presence of four or more species of cold water benthic invertebrates from this list can be used to assign a Class III-PHWH use designation to an undesignated headwater stream.

As an alternative to a detailed laboratory identification of cold water macroinvertebrate taxa, the qualitative Headwater Macroinvertebrate Field Evaluation Index (HMFEI) method can be used to assign a use designation to a PHWH stream as detailed on Page 4 of the PHWH Form (Attachment 1). Where data regarding the presence of both cold water adapted taxa and HMFEI data are available, the more detailed taxonomic approach to genus-species level of taxonomy will be used to make a final PHWH stream use designation.

---

### **Determination of a Class II-PHWH stream (warm water adapted community)**

---

A Class II-PHWH stream will be identified by the presence of warmwater adapted species of vertebrates (either fish or amphibians) **and/or** warmwater species of benthic macroinvertebrates that score a HMFEI score of >6 and <20. Lists of warmwater vertebrates found in Class II-PHWH streams are found in Tables 4 and 5.

---

### **Determination of a Class I-PHWH stream (ephemeral flow)**

---

A PHWH stream that lacks any evidence of obligate vertebrate aquatic life, or has a benthic macroinvertebrate HMFEI score less than 7, has a very high probability of becoming ephemeral. These types of headwater streams represent the highest percentage of all PHWH streams in Ohio [about 45 to 50 % of all headwater streams with watershed area 1.0 mi<sup>2</sup> (259 ha) or less]. Salamanders of the genera *Plethodon* and *Ambystoma* may be found in Class I-PHWH stream corridors.

## 8.0 Summary of Steps to Use to Assign an Aquatic Life Use Designation to a PHWH Stream.

The following steps outline a sequential protocol to be used to reach a final aquatic life use decision for an undesignated PHWH stream. The sequence presented is in rank order of techniques beginning with those that are least costly and time consuming and progressing to those that are most costly and time consuming. The HHEI allows for a rapid assessment to determine the potential of aquatic life use of a stream based entirely upon physical measurements. By design, this categorization tool has a high probability of over-classifying a stream (e.g. indicating that a Class I PHWH is a Class II PHWH, etc.) since it is based upon metrics designed to minimize the potential of under-classifying Class III PHWH streams. A biological survey must be conducted in situations where the HHEI classification is insufficient to classify the stream based upon the lack of adequate calibration data (e.g. rheocrene streams, see [Section 5.4](#), and [Figure 15](#)) or where observations in the field lead the investigator to believe that data is necessary to falsify or confirm the use classification based upon the HHEI scoring. Stark differences between HHEI and biological classification outcomes may be evidence of pollution-related stress to the aquatic biological community in the stream in situations where natural conditions do not exist that would obviously impair the support of a well balanced PHWH assemblage of organisms. A weight-of-evidence approach should be used to make a final use designation determination. Increased confidence that a correct decision has been made will be obtained when the HHEI classification is accompanied with a biological evaluation of the stream. A complete biological evaluation with all collected taxa identified to the lowest practicable taxonomic level is definitive in classifying PHWH streams. Steps 1 and 2 represent rapid-assessment approaches.

1. Conduct an HHEI Assessment. Use the decision making flowchart in Figure 15 to determine potential aquatic life use designation.

### **If there is reason to question the HHEI survey results, then**

2. Conduct a rapid bio-assessment of the benthic macroinvertebrate community and vertebrate community. Apply the HMFEL scoring criteria from Section 6.3.2 (Page 4 of Attachment 1). Apply the salamander criteria found in Table 5 (Section 6.2). The presence of cold water fish indicator species (Table 4) indicates the stream is a Class III-PHWH.

### **If there is reason to question the HMFEL results, and no cold-cool water vertebrates are present, then**

3. Identify macroinvertebrate voucher sample to the lowest taxonomic level (seek Ohio EPA guidance) in order to identify the presence of cold water adapted taxa as listed in Attachment 3. If 4 or more cold water taxa are collected, the stream is a Class III-PHWH stream. If < 4 cool water taxa, assign the Class II PHWH classification.

## 9.0 Recommended Levels of Protection for PHWH Stream Classes

Different types and degrees of aquatic life protection should be given to protect and restore the biological integrity present in the three different classes of PHWH streams in Ohio. The following discussion presents ideas that should be considered when impacts are contemplated or proposed relating to PHWH streams in Ohio. It is recommended that any antidegradation review impacts relating to PHWH streams follow this strategy whenever possible.

**Class I-PHWH** streams, due to their ephemeral nature, can be managed using a non-aquatic life approach that focuses upon the protection of downstream uses related to watershed hydrologic function, such as mitigation of changes related to water energy, sediment retention, flood storage, and riparian function.

**Class II-PHWH** streams represent a moderately diverse assemblage of vertebrates and benthic macroinvertebrates that are well adapted to a spectrum of warmwater flow hydrology, similar to the current WWH aquatic life use designation found in OAC Chapter 3745-1. As such, Class II-PHWH streams should receive protection identical to larger streams currently designated WWH in OAC Chapter 3745-1.

**Class III-PHWH** streams represent a very unique assemblage of cool-cold water adapted species of fish, and/or salamanders, and/or cold water adapted benthic macroinvertebrates that require flowing water on an annual basis for the resident species to complete their life cycles. On a statewide basis, Class III-PHWH streams are uncommon, representing approximately 16% of all PHWH streams less than 1.0 mi<sup>2</sup> (259 ha) (Table 1). These streams may be more abundant in localized geologic areas of the state associated with groundwater recharge glacial end moraines or similar geologic formations. Class III PHWH streams should receive water quality criteria protection identical to larger streams currently designated Cold Water Habitat (CWH) in OAC Chapter 3745-1. Given their unique requirement for perennial flowing cool-cold water, all efforts should be taken to avoid direct impacts to Class III PHWH stream channels and to protect natural riparian and flow hydrology, including groundwater recharge areas. If a Class III PHWH stream must be modified, then attempts should be made to restore the stream channel and flow hydrology back to natural conditions. Suitable additional mitigation through preservation of equivalent habitats should also be provided in these situations.



## 10.0 REFERENCES

- Anderson, P., R. D. Davic, S. Tuckerman. 1999. Primary headwater habitat assessment program field evaluation manual, training version. Ohio EPA, Division of Surface Water, Columbus, Ohio.
- Alexander, R. B, E. W. Boyer, R. A. Smith, G. E. Schwarz, and R. B. Moore. The role of headwater streams in downstream water quality. *Journal Of The American Water Resources Association* 43:41-49
- Bevenger, G.S. and R.M. King. 1995. A pebble count procedure for assessing watershed cumulative effects. Research Paper RM-RP-319. Fort Collins, CO: U.S. Department of Agriculture, Forest Service, Rocky Mountain Forest and Range Experiment Station. 17 pp. <http://www.treesearch.fs.fed.us/pubs/20748>  
[NOTE: downloadable software available at <http://www.stream.fs.fed.us/publications/software.html> ]
- Bouchard, R. W. 2004. Guide to aquatic macroinvertebrates of the Upper Midwest. Water Resources Center, University of Minnesota, St. Paul, Minnesota. 208 pp.”
- Conant, R., and J. T. Collins. 1991. A field guide to reptiles and amphibians of eastern and central North America, Third Edition. Houghton Mifflin Co., 450 pp.
- Davic, R. D. 1996. Standardized field sampling methods for assessing headwater habitat streams in Ohio. Final Draft. Ohio EPA, Division of Surface Water, Northeast District Office, Twinsburg, Ohio.
- Dunne T., and L. B. Leopold. 1978. Water in Environmental Planning. W. H. Freeman and Co. 818 pp.
- Government of British Columbia. 1998. Fish-stream identification guidebook, Second Edition.
- Harding, J. 1997. Amphibians and reptiles of the Great Lakes region. The University of Michigan Press, Ann Arbor, MI.
- Heyer, W. R. et.al, 1994. Measuring and monitoring biological diversity-standard methods for amphibians. Smithsonian Institution Press, Washington, DC. 364 pp.
- Hulse, A.C., C.J. McCoy, and E. Censky. 2001. Amphibians and reptiles of Pennsylvania and the Northeast. Comstock Publishing Associates, Ithaca, NY. 419 pp.
- Kondolf, G. M. and S. Li. 1992. The pebble count technique for quantifying surface bed material size in instream flow studies. *Rivers* 3:80-87.
- Kondolf, G. M. 1995. Discussion: use of pebble counts to evaluate fine sediment increase in stream channels. *Water Res. Bull.* 31:537-538.
- Mack, J. J. 2001. Vegetation index of biotic integrity (VIBI) for wetlands: ecoregional, hydrogeomorphic, and plant community comparisons with preliminary wetland aquatic life use designations. Final report to US EPA Grant No. CD985875-01. Ohio Environmental Protection Agency. Division of Surface Water, Columbus, Ohio.

- Merritt R. W., and K. W. Cummins, and M. B. Berg. 2008. An introduction to the aquatic insects of North America, Fourth Edition. Kendall Hunt Pub. Co., Dubuque, Iowa. 1158 pp.
- Meyer, J.L. and J.B. Wallace. 2001. Lost linkages and lotic ecology: rediscovering small streams. pp. 295-317. In: M.C. Press, N. Huntly and S. Levin (eds.) Ecology: Achievement and Challenge. Blackwell Science.
- Meyer, J. L., D. L. Strayer, J. B. Wallace, S. L. Eggert, G. S. Helfman, and N. E. Leonar. 2007. The contribution of headwater streams to biodiversity in river networks. Journal American Water Resources Association 43:86-103
- Micacchion, M. 2002. Amphibian index of biotic integrity (AmphIBI) for wetlands. Final report to US EPA Grant No. CD985875-01. Ohio Environmental Protection Agency. Wetland Ecology Group, Division of Surface Water, Columbus, Ohio.
- Ohio Department of Natural Resources. 2008. Amphibians of Ohio Field Guide. ODNR Division of Wildlife Publication 348 (308). Columbus, Ohio. 47 pp.  
<http://ohiodnr.com/tabid/20293/Default.aspx>
- Ohio Environmental Protection Agency, 1989. Biological criteria for the protection of aquatic life, Vol. III: Standardized biological field sampling and laboratory methods for assessing fish and macro invertebrate communities. Ohio EPA Division of Surface Water, Columbus, Ohio.  
<http://www.epa.ohio.gov/dsw/bioassess/BioCriteriaProtAqLife.aspx>
- \_\_\_\_\_. 2002 a. Field evaluation Manual for Ohio's Primary Headwater Habitat Streams. Final Ver. 1.0. Ohio EPA Division of Surface Water, Columbus, Ohio. 60 pp.
- \_\_\_\_\_. 2002 b. Ohio EPA Primary Headwater Habitat Initiative Data Compendium, 1999-2000 Habitat, Chemistry, and Stream Morphology Data. Ohio EPA Division of Surface Water, Columbus, Ohio. 84 pp.  
[http://www.epa.ohio.gov/portals/35/wqs/headwaters/PHWH\\_Compndium.pdf](http://www.epa.ohio.gov/portals/35/wqs/headwaters/PHWH_Compndium.pdf)
- \_\_\_\_\_. 2002 c. Technical Report: Ohio's Primary Headwater Streams-Fish and Amphibian Assemblages. Ohio EPA Division of Surface Water, Columbus, Ohio. 41 pp.  
[http://www.epa.ohio.gov/portals/35/wqs/headwaters/TechRep\\_FishAmphibian\\_2002.pdf](http://www.epa.ohio.gov/portals/35/wqs/headwaters/TechRep_FishAmphibian_2002.pdf)
- \_\_\_\_\_. 2002 d. Technical Report: Ohio's Primary Headwater Streams-Macroinvertebrate Assemblages. Ohio EPA Division of Surface Water, Columbus, Ohio. 25 pp.  
[http://www.epa.ohio.gov/portals/35/wqs/headwaters/TechRep\\_Macroinvert\\_2002.pdf](http://www.epa.ohio.gov/portals/35/wqs/headwaters/TechRep_Macroinvert_2002.pdf)
- \_\_\_\_\_. 2003. Fact Sheet: the importance and benefits of primary headwater streams. Ohio EPA Division of Surface Water, Columbus, Ohio.  
[http://www.epa.ohio.gov/portals/35/wqs/headwaters/HWH\\_import\\_jan2003.pdf](http://www.epa.ohio.gov/portals/35/wqs/headwaters/HWH_import_jan2003.pdf)
- \_\_\_\_\_. 2006 a. Methods for Assessing Habitat in Flowing Waters: Using the Qualitative Habitat Evaluation Index (QHEI). Ohio EPA Division of Surface Water, Columbus, Ohio. 26 pp.  
<http://www.epa.ohio.gov/portals/35/documents/QHEIManualJune2006.pdf>
- \_\_\_\_\_. 2006 b. Manual of Ohio EPA Surveillance Methods and Quality Assurance Practices. Ohio EPA Division of Surface Water, Columbus, Ohio. 60 pp.

- \_\_\_\_\_. 2008. Ohio 2008 Integrated Water Quality Monitoring and Assessment Report. Ohio EPA Division of Surface Water, Columbus, Ohio. 60 pp.  
<http://www.epa.ohio.gov/dsw/tmdl/2008IntReport/2008OhioIntegratedReport.aspx>
- \_\_\_\_\_. 2008 b. Updates to Biological Criteria for the Protection of Aquatic Life: Volume III. Standardized Biological Field Sampling and Laboratory Methods for Assessing Fish and Macroinvertebrate Communities. 11 pp.  
[http://www.epa.ohio.gov/portals/35/documents/BioCrit88\\_Vol3Updates2008.pdf](http://www.epa.ohio.gov/portals/35/documents/BioCrit88_Vol3Updates2008.pdf)
- \_\_\_\_\_. 2008 c. 2008 Updates to Biological Criteria for the Protection of Aquatic Life: Volume II and Volume II Addendum. Users Manual for Biological Field Assessment of Ohio Surface Waters. Ohio EPA Division of Surface Water. Columbus, Ohio 14 pp.  
[http://www.epa.ohio.gov/portals/35/documents/BioCrit88\\_Vol2Updates2008.pdf](http://www.epa.ohio.gov/portals/35/documents/BioCrit88_Vol2Updates2008.pdf)
- Ohio State University. 2001. Headwater rapid assessment study. Report prepared for Ohio EPA, Division of Surface Water by Statistical Consulting Service, Department of Statistics, The Ohio State University, Columbus, Ohio.
- Smith, D. G. 2001. Pennak's Freshwater Invertebrates of the United States, Porifera to Crustacea. Fourth Edition. John Wiley and Sons, New York, New York. 638 pp.
- Peterson, B.J., W. M. Wollheim, P.J. Mulholland, J.R. Webster, J.L. Meyer, J.L. Tank, E. Martí, W.B. Bowden, H.M. Valett, A.E. Hershey, W.H. McDowell, W.K. Dodds, S.K. Hamilton, S. Gregory, and D.D. Morrall. 2001. Control of Nitrogen Export from Watersheds by Headwater Streams. *Science* 292:86-90.
- Petranka., J. W. 1998. Salamanders of United States and Canada. Smithsonian Institution Press, Washington, DC. 587 pp.
- Pfingsten, R. A. 1998. Distribution of Ohio amphibians. *in*, M. J. Lannoo, editor. Status and conservation of midwestern amphibians. University of Iowa Press. 507 pp.
- Pfingsten, R. A. and F. Downs, eds. 1989. Salamanders of Ohio. *Ohio Biol. Surv. Bull. New Series Vol 7 No. 2.* 315 pp.
- Pfingsten, R. A. and T. O. Matson. 2003. Ohio Salamander Atlas. Ohio Biological Survey, Columbus, Ohio. 32 pp.
- Rankin, E. 1989. The qualitative habitat evaluation index (QHEI): Rational, methods, and applications. Ohio EPA, Division of Surface Water, Columbus, Ohio.
- Rankin, E. T. 1995. The use of habitat assessments in water resource management programs, pp. 181-208. *in* W. Davis and T. Simon (eds.). *Biological Assessment and Criteria: Tools for Water Resource Planning and Decision Making.* Lewis Publishers, Boca Raton, FL.
- Rocco, G. L., and R. P. Brooks. 2000. Abundance and distribution of a stream plethodontid salamander assemblage in 14 ecologically dissimilar watersheds in the Pennsylvania central Appalachians. Penn State Cooperative Wetlands Center, Forest Resources Laboratory. Report No. 2000-4, prepared for: U.S. EPA, Region III.

- Rosgen, D. 1996. Applied River Morphology. Wildland Hydrology. Pagosa Springs, Colorado. 343 pp.
- Straub, D. E. 2001. Low-flow characteristics of streams in Ohio through Water Year 1997. Water-Resources Investigations Report 01-4140. United States Geologic Survey, Columbus, OH. 415 pp.
- Trautman, M. B. 1981. The fishes of Ohio. Ohio State University Press. Columbus, Ohio. 782 pp.
- United States Environmental Protection Agency, 1989. Rapid bioassessment protocols for use in streams and rivers. EPA/444/4-89-001.
- United States Geological Survey. 2001. Low-flow characteristics of streams in Ohio through water year 1997. Water-Resources Investigations Report 01-4140. USGS, Columbus, Ohio. 415 pp. <http://oh.water.usgs.gov/reports/Abstracts/wrir01-4140.html>
- United States Fish and Wildlife Service. 1981. Standards for the development of habitat suitability index models for use in the Habitat Evaluation Procedures. USDI Fish and Wildlife Service. Division of Ecological Services. ESM 103.
- Vannote, R. L., G. W. Minshall, K. W. Cummins, J. R. Sedell, and C. E. Cushing. The river continuum concept. Can. J. Fish. And Aq. Sci. 37:130-137.
- Voshell, J. R. Jr. 2002. A Guide to Common Freshwater Invertebrates of North America. McDonald and Woodward Publishing Co., Blacksburg, VA. 442 pp.
- Wipfli, M. 2005. Rophic linkages between headwater forests and downstream fish habitats: implications for forest and fish management. Landscape and Urban Planning 72:205-213.
- Wolman, M. G. 1954. A method for sampling coarse river-bed material. Trans. Amer. Geophysical Journal 35:951-956.

**THIS PAGE INTENTIONALLY LEFT BLANK**

## **Attachment 1**

### **The Ohio EPA Primary Headwater Habitat Evaluation Form**

#### **(PHWH Form)**

***Note: An automated adobe acrobat evaluation form can be downloaded at the following URLs:***

**HHEI form:**

[http://www.epa.ohio.gov/portals/35/wqs/headwaters/HHEI\\_Form\\_Clickable\\_10-02.pdf](http://www.epa.ohio.gov/portals/35/wqs/headwaters/HHEI_Form_Clickable_10-02.pdf)

**Biological Assessment:**

[http://www.epa.ohio.gov/portals/35/wqs/headwaters/PHWH\\_Biology\\_Forms\\_Clickable\\_4-03.pdf](http://www.epa.ohio.gov/portals/35/wqs/headwaters/PHWH_Biology_Forms_Clickable_4-03.pdf)



# Primary Headwater Habitat Evaluation Form

HHEI Score (sum of metrics 1, 2, 3) :

SITE NAME/LOCATION \_\_\_\_\_

\_\_\_\_\_ SITE NUMBER \_\_\_\_\_ RIVER BASIN \_\_\_\_\_ DRAINAGE AREA (mi<sup>2</sup>) \_\_\_\_\_

LENGTH OF STREAM REACH (ft) \_\_\_\_\_ LAT. \_\_\_\_\_ LONG. \_\_\_\_\_ RIVER CODE \_\_\_\_\_ RIVER MILE \_\_\_\_\_

DATE \_\_\_\_\_ SCORER \_\_\_\_\_ COMMENTS \_\_\_\_\_

**NOTE: Complete All Items On This Form - Refer to "Field Evaluation Manual for Ohio's PHWH Streams" for Instructions**

**STREAM CHANNEL**     NONE / NATURAL CHANNEL     RECOVERED     RECOVERING     RECENT OR NO RECOVERY

**MODIFICATIONS:**

**1. SUBSTRATE** (Estimate percent of every type of substrate present. Check *ONLY* two predominant substrate *TYPE* boxes (Max of 40). Add total number of significant substrate types found (Max of 8). Final metric score is sum of boxes A & B.

TYPE	PERCENT	TYPE	PERCENT
<input type="checkbox"/> <input type="checkbox"/> BLDR SLABS [16 pts]	_____	<input type="checkbox"/> <input type="checkbox"/> SILT [3 pt]	_____
<input type="checkbox"/> <input type="checkbox"/> BOULDER (>256 mm) [16 pts]	_____	<input type="checkbox"/> <input type="checkbox"/> LEAF PACK/WOODY DEBRIS [3 pts]	_____
<input type="checkbox"/> <input type="checkbox"/> BEDROCK [16 pt]	_____	<input type="checkbox"/> <input type="checkbox"/> FINE DETRITUS [3 pts]	_____
<input type="checkbox"/> <input type="checkbox"/> COBBLE (65-256 mm) [12 pts]	_____	<input type="checkbox"/> <input type="checkbox"/> CLAY or HARDPAN [0 pt]	_____
<input type="checkbox"/> <input type="checkbox"/> GRAVEL (2-64 mm) [9 pts]	_____	<input type="checkbox"/> <input type="checkbox"/> MUCK [0 pts]	_____
<input type="checkbox"/> <input type="checkbox"/> SAND (<2 mm) [6 pts]	_____	<input type="checkbox"/> <input type="checkbox"/> ARTIFICIAL [3 pts]	_____

Total of Percentages of Bldr Slabs, Boulder, Cobble, Bedrock \_\_\_\_\_ (A)  (B)

SCORE OF TWO MOST PREDOMINATE SUBSTRATE TYPES: \_\_\_\_\_

TOTAL NUMBER OF SUBSTRATE TYPES: \_\_\_\_\_

**HHEI Metric Points**

Substrate  
Max = 40

A + B

**2. Maximum Pool Depth** (Measure the maximum pool depth within the 61 meter (200 ft) evaluation reach at the time of evaluation. Avoid plunge pools from road culverts or storm water pipes) (Check *ONLY* one box):

<input type="checkbox"/> > 30 centimeters [20 pts]	<input type="checkbox"/> > 5 cm - 10 cm [15 pts]
<input type="checkbox"/> > 22.5 - 30 cm [30 pts]	<input type="checkbox"/> < 5 cm [5 pts]
<input type="checkbox"/> > 10 - 22.5 cm [25 pts]	<input type="checkbox"/> NO WATER OR MOIST CHANNEL [0 pts]

COMMENTS \_\_\_\_\_ MAXIMUM POOL DEPTH (centimeters):

Pool Depth  
Max = 30

**3. BANK FULL WIDTH** (Measured as the average of 3-4 measurements) (Check *ONLY* one box):

<input type="checkbox"/> > 4.0 meters (> 13') [30 pts]	<input type="checkbox"/> > 1.0 m - 1.5 m (> 3' 3" - 4' 8") [15 pts]
<input type="checkbox"/> > 3.0 m - 4.0 m (> 9' 7" - 13') [25 pts]	<input type="checkbox"/> ≤ 1.0 m (≤ 3' 3") [5 pts]
<input type="checkbox"/> > 1.5 m - 3.0 m (> 4' 8" - 9' 7") [20 pts]	

COMMENTS \_\_\_\_\_ AVERAGE BANKFULL WIDTH (meters)

Bankfull  
Width  
Max=30

This information **must** also be completed

**RIPARIAN ZONE AND FLOODPLAIN QUALITY** ☆NOTE: River Left (L) and Right (R) as looking downstream☆

RIPARIAN WIDTH		FLOODPLAIN QUALITY			
L	R	L	R	L	R
<input type="checkbox"/>	<input type="checkbox"/>	<input type="checkbox"/>	<input type="checkbox"/>	<input type="checkbox"/>	<input type="checkbox"/>
Wide >10m	(Per Bank)	Mature Forest, Wetland	(Most Predominant per Bank)	Conservation Tillage	
<input type="checkbox"/>	<input type="checkbox"/>	<input type="checkbox"/>	<input type="checkbox"/>	<input type="checkbox"/>	<input type="checkbox"/>
Moderate 5-10m		Immature Forest, Shrub or Old Field		Urban or Industrial	
<input type="checkbox"/>	<input type="checkbox"/>	<input type="checkbox"/>	<input type="checkbox"/>	<input type="checkbox"/>	<input type="checkbox"/>
Narrow <5m		Residential, Park, New Field		Open Pasture, Row Crop	
<input type="checkbox"/>	<input type="checkbox"/>	<input type="checkbox"/>	<input type="checkbox"/>	<input type="checkbox"/>	<input type="checkbox"/>
None		Fenced Pasture		Mining or Construction	

COMMENTS \_\_\_\_\_

**FLOW REGIME** (At Time of Evaluation) (Check *ONLY* one box):

<input type="checkbox"/> Stream Flowing	<input type="checkbox"/> Moist Channel, isolated pools, no flow (Intermittent)
<input type="checkbox"/> Subsurface flow with isolated pools (Interstitial)	<input type="checkbox"/> Dry channel, no water (Ephemeral)

COMMENTS \_\_\_\_\_

**SINUOSITY** (Number of bends per 61 m (200 ft) of channel) (Check *ONLY* one box):

<input type="checkbox"/> None	<input type="checkbox"/> 1.0	<input type="checkbox"/> 2.0	<input type="checkbox"/> 3.0
<input type="checkbox"/> 0.5	<input type="checkbox"/> 1.5	<input type="checkbox"/> 2.5	<input type="checkbox"/> >3

**STREAM GRADIENT ESTIMATE**

Flat (0.5 ft/100 ft)     Flat to Moderate     Moderate (2 ft/100 ft)     Moderate to Severe     Severe (10 ft/100 ft)

---

**ADDITIONAL STREAM INFORMATION (This Information Must Also be Completed):**

**QHEI PERFORMED?** -  Yes  No QHEI Score \_\_\_\_\_ (If Yes, Attach Completed QHEI Form)

**DOWNSTREAM DESIGNATED USE(S)**

WWH Name: \_\_\_\_\_ Distance from Evaluated Stream \_\_\_\_\_  
 CWH Name: \_\_\_\_\_ Distance from Evaluated Stream \_\_\_\_\_  
 EWH Name: \_\_\_\_\_ Distance from Evaluated Stream \_\_\_\_\_

**MAPPING: ATTACH COPIES OF MAPS, INCLUDING THE ENTIRE WATERSHED AREA. CLEARLY MARK THE SITE LOCATION**

USGS Quadrangle Name: \_\_\_\_\_ NRCS Soil Map Page: \_\_\_\_\_ NRCS Soil Map Stream Order \_\_\_\_\_

County: \_\_\_\_\_ Township / City: \_\_\_\_\_

**MISCELLANEOUS**

Base Flow Conditions? (Y/N): \_\_\_\_\_ Date of last precipitation: \_\_\_\_\_ Quantity: \_\_\_\_\_

Photograph Information: \_\_\_\_\_

Elevated Turbidity? (Y/N): \_\_\_\_\_ Canopy (% open): \_\_\_\_\_

Were samples collected for water chemistry? (Y/N): \_\_\_\_\_ (Note lab sample no. or id. and attach results) Lab Number: \_\_\_\_\_

Field Measures: Temp (°C) \_\_\_\_\_ Dissolved Oxygen (mg/l) \_\_\_\_\_ pH (S.U.) \_\_\_\_\_ Conductivity (µmhos/cm) \_\_\_\_\_

Is the sampling reach representative of the stream (Y/N) \_\_\_\_\_ If not, please explain: \_\_\_\_\_

Additional comments/description of pollution impacts: \_\_\_\_\_

**BIOTIC EVALUATION**

Performed? (Y/N): \_\_\_\_\_ (If Yes, Record all observations. Voucher collections optional. NOTE: all voucher samples must be labeled with the site ID number. Include appropriate field data sheets from the Primary Headwater Habitat Assessment Manual)

Fish Observed? (Y/N) \_\_\_\_\_ Voucher? (Y/N) \_\_\_\_\_ Salamanders Observed? (Y/N) \_\_\_\_\_ Voucher? (Y/N) \_\_\_\_\_  
Frogs or Tadpoles Observed? (Y/N) \_\_\_\_\_ Voucher? (Y/N) \_\_\_\_\_ Aquatic Macroinvertebrates Observed? (Y/N) \_\_\_\_\_ Voucher? (Y/N) \_\_\_\_\_

Comments Regarding Biology: \_\_\_\_\_

---

**DRAWING AND NARRATIVE DESCRIPTION OF STREAM REACH (This must be completed):**

Include important landmarks and other features of interest for site evaluation and a narrative description of the stream's location

FLOW 



**PHWH STREAM BIOLOGICAL CHARACTERISTICS FIELD SHEET:**

**1. Fish:**                      Voucher Specimens Retained? (circle) Y / N                      Time Spent (minutes): \_\_\_\_\_  
    Sample Method \_\_\_\_\_                      Stream Length Assessed (meters) \_\_\_\_\_

Species	Number Caught	Notes

**2. Salamanders:**                      Voucher Specimens Retained? (circle) Y / N                      Time Spent (minutes): \_\_\_\_\_  
    Sample Method \_\_\_\_\_                      Stream Length Assessed (meters) \_\_\_\_\_

Species (Genus)	# Larvae	# Juveniles/Adults	Total Number
<b>Mountain Dusky</b> ( <i>Desmognathus ochrophaeus</i> )			
<b>Northern Dusky</b> ( <i>Desmognathus fuscus</i> )			
<b>Two-lined</b> ( <i>Eurycea bislineata</i> )			
<b>Long-tailed</b> ( <i>Eurycea longicauda</i> )			
<b>Cave</b> ( <i>Eurycea lucifuga</i> )			
<b>Red</b> ( <i>Pseudotriton ruber</i> )			
<b>Mud</b> ( <i>Pseudotriton montanus</i> )			
<b>Spring</b> ( <i>Gyrinophilus porphyriticus</i> )			
<b>Mole spp.</b> ( <i>Ambystoma spp.</i> )			
<b>Four-toed</b> ( <i>Hemidactylum scutatum</i> )			
<b>Other (name)</b>			
<b>Total</b>			

Notes on Vertebrates: \_\_\_\_\_

### 3. Macroinvertebrate Scoring Sheet:

#### THE HEADWATER MACROINVERTEBRATE FIELD EVALUATION INDEX (HMFEI) SCORING SHEET

Indicate Abundance of Each Taxa Above each White Box.

Record HMFEI Scoring Value Points Within each Box.

For EPT taxa, also indicate the different taxa present.

**Key:** V = Very Abundant (> 50); A = Abundant (10 -50); C = Common (3 -9); R = Rare (< 3)

Sessile Animals (Porifera, Cnidaria, Bryozoa) (HMFEI pts = 1)	Crayfish (Decapoda) (HMFEI pts = 2)	Fishfly Larvae (Corydalidae) (HMFEI pts = 3)
Aquatic Worms (Turbellaria, Oligochaeta, Hirudinea) (HMFEI pts = 1)	Dragonfly Nymphs (Anisoptera) (HMFEI pts = 2)	Water Penny Beetles (Psephenidae) (HMFEI pts = 3)
Sow Bugs (Isopoda) (HMFEI pts = 1)	Riffle Beetles (Dryopidae, Elmidae, Ptilodactylidae) (HMFEI pts = 2)	Crane-fly Larvae (Tipulidae) (HMFEI pts = 3)
Scuds (Amphipoda) (HMFEI pts = 1)	Larvae of other Flies (Diptera) Name: (HMFEI pts = 1)	<b>EPT TAXA*</b> Total No. EPT Taxa = _____
Water Mites (Hydracarina) (HMFEI pts = 1)	Midges (Chironomidae) (HMFEI pts = 1)	Mayfly Nymphs (Ephemeroptera) Taxa Present: HMFEI pts = _____ No. Taxa (x) 3]
Damselfly Nymphs (Zygoptera) (HMFEI pts = 1)	Snails (Gastropoda) (HMFEI pts = 1)	
Alderfly Larvae (Sialidae) (HMFEI pts = 1)	Clams (Bivalvia) (HMFEI pts = 1)	Stonefly Nymphs (Plecoptera) Taxa Present: HMFEI pts = _____ No. Taxa (x) 3]
Other Beetles (Coleoptera) (HMFEI pts = 1)	Other Taxa :	
Other Taxa:	Other Taxa:	Caddisfly Larvae (Trichoptera) Taxa Present: HMFEI pts = _____ No. Taxa (x) 3]
Other Taxa:	Other Taxa	

\*Note: EPT identification based upon Family or Genus level of taxonomy

Voucher Sample ID \_\_\_\_\_

Time Spent (minutes): \_\_\_\_\_

Notes on Macroinvertebrates: (Predominant Organisms; Other Common Organisms; Diversity Estimate)

---



---



---

Final HMFEI Calculated Score (Sum of All White Box Scores) =

IF Final HMFEI Score is > 19, Then CLASS III PHWH STREAM  
 IF Final HMFEI Score is 7 to 19, Then CLASS II PHWH STREAM  
 IF Final HMFEI Score is < 7, Then CLASS I PHWH STREAM

## Attachment 2

### Field Check List for Primary Headwater Stream Sampling

---

#### Physical-Chemical Sampling:

- Attachment 1 PHWH field data form from HWH manual with clip board, pencil
- 100 foot tape measure, cloth
- Ruler (in cm)
- 3 color flag markers (to mark ends and mid-point of sample zone)
- 30 ft of string to measure bankfull width, with two metal stakes
- Bubble type carpenter's line level or carpenter's laser level
- Stop watch
- Camera
- Clip board, pencils
- Carry bag
- Guarded thermometer or field meter(s) [temperature, dissolved oxygen, pH, conductivity]
- Containers for potential water samples for nutrients, coliform bacteria, and/or metals
- Mosquito repellent
- Optional: GPS unit for lat./long.

#### Biological Sampling:

- Hip waders or chest waders (knee boots not recommended)
- Fine mesh kick net for invertebrate sampling
- White sorting pans (2)
- Fine tip forceps
- Specimen jars: 70% alcohol for invertebrates, and formalin solution for fish voucher samples
- Large tea strainer or fine mesh small handle invertebrate net for salamanders
- Hard plastic container with air holes in lid for salamander collection
- Heavy duty plastic bags (4) for transport of salamanders to lab
- Small cooler with ice or block ice for salamander transport and water samples
- Marker flags (2) to mark ends of sample zone
- 30 foot line to measure length of salamander sample zones
- 10 foot fish seine
- Optional: High intensity head lamp

Attachment 3. Ohio EPA cold and cool water macroinvertebrate taxa list. From “2008 Updates to Biological Criteria for the Protection of Aquatic Life: Volume II and Volume II Addendum. Users Manual for Biological Field Assessment of Ohio Surface Waters.” Ohio EPA Division of Surface Water, 14 pp. [http://www.epa.ohio.gov/portals/35/documents/BioCrit88\\_Vol2Updates2008.pdf](http://www.epa.ohio.gov/portals/35/documents/BioCrit88_Vol2Updates2008.pdf)

<b>Crustacea</b>	<b>Diptera</b>
Gammarus minus	Dicranota sp.
<b>Ephemeroptera</b>	Pedicia sp.
Ameletus sp.	Thaumalea americana
Baetis tricaudatus	Apsectrotanypus johnsoni
Epeorus sp.	Macropelopia decedens
Maccaffertium ithaca	Meropelopia sp.
Maccaffertium modestum	Radotanypus florens
Habrophlebiodes sp.	Trissopelopia ogemawi
Dannella simplex	Zavreliomyia sp.
Litobrancha recurvata	Diamesa sp.
<b>Odonata</b>	Pagastia orthogonia
Boyeria grafiana	Odontomesa ferringtoni
Lanthus parvulus	Prodiamesa olivacea
<b>Plecoptera</b>	Brillia parva
Peltoperla sp.	Chaetocladius piger
Amphinemura sp.	Corynoneura n. sp. 5
Soyedina sp.	Eukiefferiella devonica group
Leuctra sp.	Heleniella sp.
Eccoptura xanthenes	Heterotrissocladius marcidus
Sweltsa sp.	Metriocnemus eurynotus
<b>Megaloptera</b>	Parachaetocladius sp.
Nigronia fasciatus	Parametriocnemus sp.
<b>Trichoptera</b>	Psilometriocnemus triannulatus
Dolophilodes sp.	Rheocricotopus eminellobus
Wormaldia sp.	Thienemanniella boltoni
Ceratopsyche slossonae	Polypedilum (P.) albicorne
Ceratopsyche ventura	Polypedilum (P.) aviceps
Diplectronea sp.	“Constempellina” n. sp. 1
Parapsyche sp.	Micropsectra sp.
Rhyacophila sp. (excluding R. lobifera)	Neostempellina reissi
Glossosoma sp.	Neozavrelia sp. 1
Oligostomis sp.	Paratanytarsus n. sp. 1
Frenesia sp.	Stempellinella boltoni
Goera sp.	Zavrelia n. sp. 1
Lepidostoma sp.	Clinocera (Clin.) sp.
Psilotreta indecisa	Neoplasta sp.
Psilotreta rufa	
Molanna sp.	

Attachment 3. Ohio EPA cold and cool water macroinvertebrate taxa list. From “2008 Updates to Biological Criteria for the Protection of Aquatic Life: Volume II and Volume II Addendum. Users Manual for Biological Field Assessment of Ohio Surface Waters.” Ohio EPA Division of Surface Water, 14 pp. [http://www.epa.ohio.gov/portals/35/documents/BioCrit88\\_Vol2Updates2008.pdf](http://www.epa.ohio.gov/portals/35/documents/BioCrit88_Vol2Updates2008.pdf)

### **Definition**

Cold water macroinvertebrates are taxa that primarily inhabit streams that maintain a summer water temperature below about 20°C. Cold water taxa were in part chosen by analysis of the 25th, 50th, and 75th percentile statistics of the number of cold water taxa at a taxon’s collection sites during the summer collection period (June 15 to September 30). Cold water taxa generally were expected to have the 50th %ile  $\leq 3$ . Information in the published scientific literature was also considered when assigning taxa to the cold water list. Some species emerge in the spring and their larvae are not present during the summer collection period. For these taxa, the nature of the collection sites were taken into account along with an analysis of the associated taxa and a review of the scientific literature to determine if the taxa should be included on the cold water taxa list. Percentile breakdowns for each cool water taxon and literature references relevant to the assessment process noted above are available upon request from the Ohio EPA.

**Note to Users: At the time of preparation of this manual, Ohio EPA was in the process of developing proposed rules for inclusion in Chapter 3745-1 of the Ohio Administrative Code which would specify cold and cool water macroinvertebrate taxa. Upon promulgation of this rule, the rule will supersede the information in this attachment should any differences exist.**

### Attachment 4 – PWH Manual Ver. 2.3

River Code: \_\_\_\_\_ River/Stream: \_\_\_\_\_ RM: \_\_\_\_\_

Date: \_\_\_\_\_ Location: \_\_\_\_\_

Investigator: \_\_\_\_\_ Rosgen Channel Type: \_\_\_\_\_

#### *Zig/Zag Pebble Count*

Particle Size Range (mm)	Total (Dry) Channel	Total (Wetted Channel)				%	Cum%
		Riffle	Run	Pool	Glide		
Silt							
Sand (< 2)							
V Fine Gravel (2-3.9)							
Fine Gravel (4-7.9)							
Medium Gravel (8-15)							
Coarse Gravel (16-31)							
V Coarse Gravel (32-63)							
Small Cobble (64-127)							
Large Cobble (128-255)							
Small Boulder (256-511)							
Medium Boulder (512-1023)							
Large Boulder (> 1024)							
Bedrock							
Clay Hardpan							

Bank Full Width: \_\_\_\_\_ Bankfull Max Depth: \_\_\_\_\_ Channel Slope \_\_\_\_\_

Bank Full Mean Depth \_\_\_\_\_ Flood Prone Area Width: \_\_\_\_\_ Valley Slope: \_\_\_\_\_

Width/Depth Ratio \_\_\_\_\_ Entrenchment Ratio \_\_\_\_\_ Sinuosity \_\_\_\_\_

Attachment 5 – PWH Manual Ver. 2.3

Collection ID #: \_\_\_\_\_

Ohio EPA  
Headwater Stream Salamander Voucher Data Sheet

Date Collected: \_\_\_\_\_ Time: \_\_\_\_\_

Site Name: \_\_\_\_\_

Location: \_\_\_\_\_

Tributary of: \_\_\_\_\_

County: \_\_\_\_\_; Township: \_\_\_\_\_

County Soil Map Page: \_\_\_\_\_; USGS Topo Map: \_\_\_\_\_

Road/Bridge: \_\_\_\_\_

Latitude: \_\_\_\_\_ N; Longitude \_\_\_\_\_ W

Average Bankfull Width (meters): \_\_\_\_\_; Maximum Pool Depth (cm): \_\_\_\_\_

Two Dominant Stream Bed Substrate Types: \_\_\_\_\_; \_\_\_\_\_

Riparian Vegetation Description: \_\_\_\_\_

Temp (°C) \_\_\_\_\_; DO (mg/l) \_\_\_\_\_; pH \_\_\_\_\_; Cond (umhos/cm) \_\_\_\_\_

Stream Gradient Estimate (% Slope in ft/100 ft): \_\_\_\_\_ within 200 ft stream reach

Watershed Area: (sq mi) \_\_\_\_\_; (km) \_\_\_\_\_; (ha) \_\_\_\_\_

Were fish present? (Y) \_\_\_\_\_; (N) \_\_\_\_\_; Species: \_\_\_\_\_, \_\_\_\_\_,

\_\_\_\_\_, \_\_\_\_\_, \_\_\_\_\_, \_\_\_\_\_

Water Type: Spring-seep near source \_\_\_\_\_; Headwater Stream \_\_\_\_\_; Other: \_\_\_\_\_

Type of Flow: Complete Surface Flow \_\_\_\_\_; Interstitial Flow \_\_\_\_\_; Isolated Pools-Moist Soil

but not Flowing (Intermittent) \_\_\_\_\_; Dry Channel Entire Length: \_\_\_\_\_

Collectors: \_\_\_\_\_

Salamander Species Collected:

Age Class:

_____	_____	Number ( )
_____	_____	Number ( )
_____	_____	Number ( )
_____	_____	Number ( )
_____	_____	Number ( )
_____	_____	Number ( )
_____	_____	Number ( )

Tentative Identifications by: \_\_\_\_\_

\*\*\* Upon completion, this form can be copy reduced to fit inside the voucher container \*\*\*

# Appendix B













Longitudinal Slope P Longitudir Longitudinal Slope Prol

---

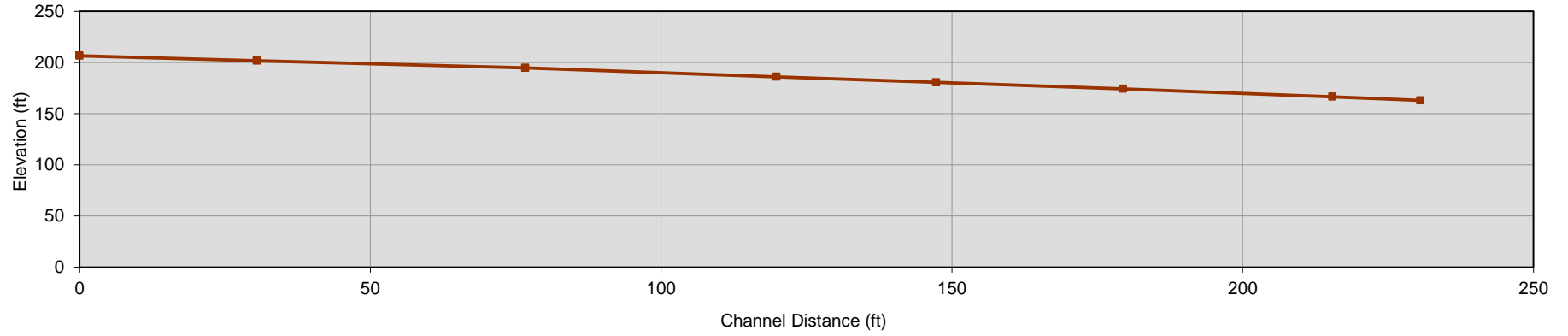
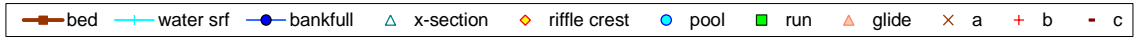

	slope (%)	slope ratio	length (ft)	length ratio	pool-pool spacing (ft)	p-p ratio
reach	19	---	230.5 (18.3 channel widths)	---	---	---
riffle	---	---	---	---	---	---
pool	---	---	---	---	---	---
	---	---	---	---	---	---

**THE RIVER EVALUATION TOOL RIVER SPREADSHEET**

**For Channel Survey Data Management**

**version 4.1 T**

A **STREAM** Module: **S**preadsheet **T**ools for **R**iver **E**valuation, **A**ssessment and **M**onitoring

Dan Mecklenburg, Ohio Department of Natural Resources



Summary					
Stream:	---				
Watershed:	---				
Location:	---				
Latitude:	---				
Longitude:	---				
State:	---				
County:	---				
Date:	---				
Observers:	---				
Channel type:	---				
Drainage area (sq.mi.):	---				
notes:	---				
Dimension		bankfull channel			
		typical	min	max	
floodplain:	width flood prone area (ft)	17.3	---	---	
	low bank height (ft)	---	---	---	
riffle-run:	x-area bankfull (sq.ft.)	3.5	1.8	5.4	
	width bankfull (ft)	12.6	10.7	14.6	
	mean depth (ft)	0.28	0.1	0.4	
	max depth (ft)	0.6	0.2	0.8	
	hydraulic radius (ft)	0.3	---	---	
pool:	x-area pool (sq.ft.)	---	---	---	
	width pool (ft)	---	---	---	
	max depth pool (ft)	---	---	---	
	hydraulic radius (ft)	---	---	---	
dimensionless ratios:		typical	min	max	
	width depth ratio	44.9	33.2	88.5	
	entrenchment ratio	1.4	---	---	
	riffle max depth ratio	2.0	0.9	2.7	
	bank height ratio	---	---	---	
	pool area ratio	---	---	---	
	pool width ratio	---	---	---	
	pool max depth ratio	---	---	---	
hydraulics:		typical	min	max	
	discharge rate (cfs)	---	---	---	
	channel slope (%)	19	---	---	
		riffle-run	min	max	pool
	velocity (ft/s)	---	---	---	---
	Froude number	---	---	---	---
	shear stress (lbs/sq.ft.)	3.260	1.667	3.757	---
	shear velocity (ft/s)	1.297	0.928	1.392	---
	stream power (lb/s)	---	---	---	---
	unit stream power (lb/ft/s)	---	---	---	---
	relative roughness	---	---	---	---
	friction factor u/u*	---	---	---	---
	threshold grain size (t*=0.06) (mm)	160.2	82.0	184.7	---
	Shield's parameter	---	---	---	---
Pattern		typical	min	max	
	meander length (ft)	---	---	---	
	belt width (ft)	---	---	---	
	amplitude (ft)	---	---	---	
	radius (ft)	---	---	---	
	arc angle (degrees)	---	---	---	
	stream length (ft)	230.5	---	---	
	valley length (ft)	227.3	---	---	
	Sinuosity	1.0	---	---	
	Meander Length Ratio	---	---	---	
	Meander Width Ratio	---	---	---	
	Radius Ratio	---	---	---	



Longitudinal Slope P Longitudir Longitudinal Slope Prol

---

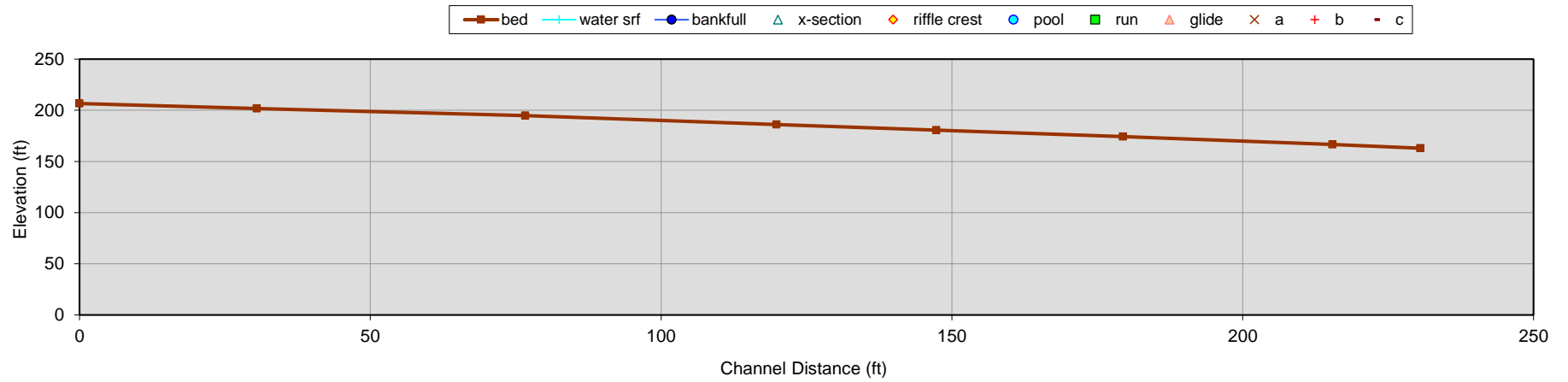

	slope (%)	slope ratio	length (ft)	length ratio	pool-pool spacing (ft)	p-p ratio
reach	19	---	230.5 (18.3 channel widths)	---	---	---
riffle	---	---	---	---	---	---
pool	---	---	---	---	---	---
	---	---	---	---	---	---



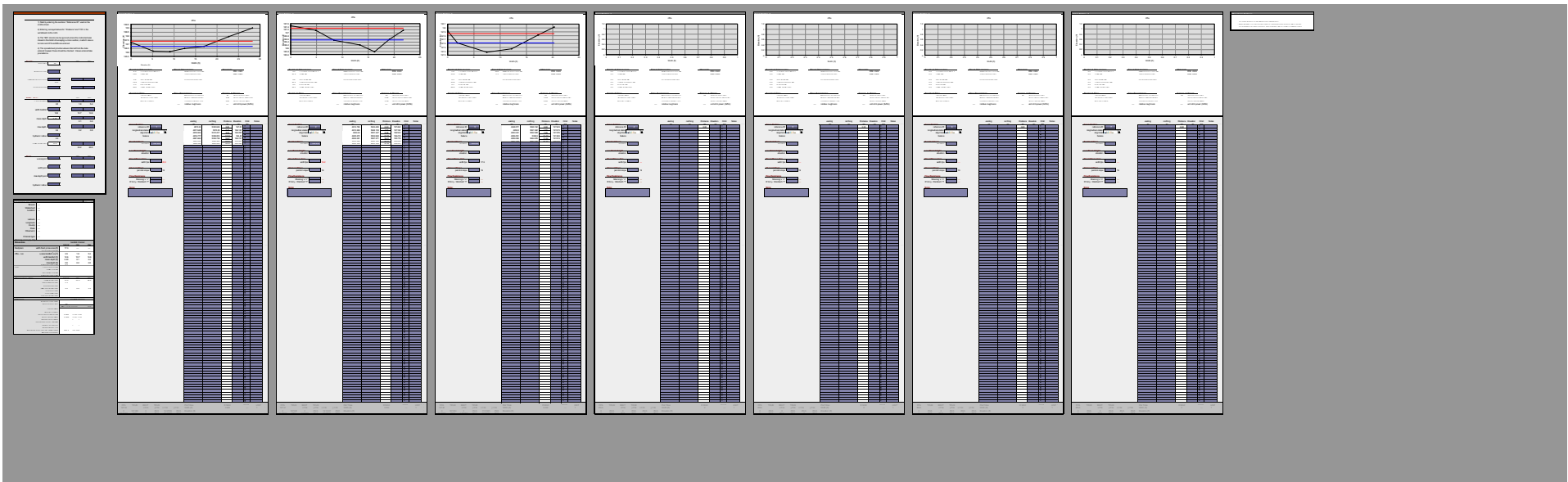



# Appendix C

**(Biological HHEI, MFEI Biological, Assessment, and  
Reconstructed HHEI Forms)**

## PHWH STREAM BIOLOGICAL CHARACTERISTICS FIELD SHEET:

**1. Fish:**                      Voucher Specimens Retained? (select)                      Time Spent (minutes): \_\_\_\_\_  
    Sample Method \_\_\_\_\_                      Stream Length Assessed (meters) \_\_\_\_\_

Species	Number Caught	Notes

**2. Salamanders:**                      Voucher Specimens Retained? (circle) Y / N                      Time Spent (minutes): \_\_\_\_\_  
    Sample Method \_\_\_\_\_                      Stream Length Assessed (meters) \_\_\_\_\_

Species ( <i>Genus</i> )	# Larvae	# Juveniles/Adults	Total Number
<b>Mountain Dusky</b> ( <i>Desmognathus ochrophaeus</i> )			
<b>Northern Dusky</b> ( <i>Desmognathus fuscus</i> )			
<b>Two-lined</b> ( <i>Eurycea bislineata</i> )			
<b>Long-tailed</b> ( <i>Eurycea longicauda</i> )			
<b>Cave</b> ( <i>Eurycea lucifuga</i> )			
<b>Red</b> ( <i>Pseudotriton ruber</i> )			
<b>Mud</b> ( <i>Pseudotriton montanus</i> )			
<b>Spring</b> ( <i>Gyrinophilus porphyriticus</i> )			
<b>Mole spp.</b> ( <i>Ambystoma spp.</i> )			
<b>Four-toed</b> ( <i>Hemidactylium scutatum</i> )			
<b>Other (name)</b>			
<b>Total</b>			

**Notes on Vertebrates:** \_\_\_\_\_

### 3. Macroinvertebrate Scoring Sheet:

#### THE HEADWATER MACROINVERTEBRATE FIELD EVALUATION INDEX (HMFEI) SCORING SHEET

Indicate Abundance of Each Taxa Above each White Box.

Record HMFEI Scoring Value Points Within each Box.

For EPT taxa, also indicate the different taxa present.

**Key:** **V** = Very Abundant (> 50); **A** = Abundant (10 -50); **C** = Common (3 -9); **R** = Rare (< 3)

Sessile Animals ( <b>Porifera</b> , <b>Cnidaria</b> , <b>Bryozoa</b> ) (HMFEI pts = 1)	<input type="text"/>	Crayfish ( <b>Decapoda</b> ) (HMFEI pts = 2)	<input type="text"/>	Fishfly Larvae ( <b>Corydalidae</b> ) (HMFEI pts = 3)	<input type="text"/>
Aquatic Worms ( <b>Turbellaria</b> , <b>Hirudinea</b> , <b>Oligochaeta</b> ) (HMFEI pts = 1)	<input type="text"/>	Dragonfly Nymphs ( <b>Anisoptera</b> ) (HMFEI pts = 2)	<input type="text"/>	Water Penny Beetles ( <b>Psephenidae</b> ) (HMFEI pts = 3)	<input type="text"/>
Sow Bugs ( <b>Isopoda</b> ) (HMFEI pts = 1)	<input type="text"/>	Riffle Beetles ( <b>Dryopidae</b> , <b>Elmidae</b> , <b>Ptilodactylidae</b> ) (HMFEI pts = 2)	<input type="text"/>	Crane-fly Larvae ( <b>Tipulidae</b> ) (HMFEI pts = 3)	<input type="text"/>
Scuds ( <b>Amphipoda</b> ) (HMFEI pts = 1)	<input type="text"/>	Larvae of other Flies (enter name in comments) ( <b>Diptera</b> ): (HMFEI pts = 1)	<input type="text"/>	<b>EPT TAXA*</b>	
Water Mites ( <b>Hydracarina</b> ) (HMFEI pts = 1)	<input type="text"/>	Midges ( <b>Chironomidae</b> ) (HMFEI pts = 1)	<input type="text"/>	Total No. EPT Taxa = _____	
Damselfly Nymphs ( <b>Zygoptera</b> ) (HMFEI pts = 1)	<input type="text"/>	Snails ( <b>Gastropoda</b> ) (HMFEI pts = 1)	<input type="text"/>	Mayfly Nymphs ( <b>Ephemeroptera</b> ) Taxa Present: HMFEI pts = _____	<input type="text"/>
Alderfly Larvae ( <b>Sialidae</b> ) (HMFEI pts = 1)	<input type="text"/>	Clams ( <b>Bivalvia</b> ) (HMFEI pts = 1)	<input type="text"/>	No. Taxa (x) 3] _____	
Other Beetles ( <b>Coleoptera</b> ) (HMFEI pts = 1)	<input type="text"/>	Other Taxa :		Stonefly Nymphs ( <b>Plecoptera</b> ) Taxa Present: HMFEI pts = _____	<input type="text"/>
Other Taxa:		Other Taxa:		No. Taxa (x) 3] _____	
Other Taxa:		Other Taxa:		Caddisfly Larvae ( <b>Trichoptera</b> ) Taxa Present: HMFEI pts = _____	<input type="text"/>
Other Taxa:		Other Taxa:		No. Taxa (x) 3] _____	

\*Note: EPT identification based upon Family or Genus level of taxonomy

Voucher Sample ID \_\_\_\_\_

Time Spent (minutes): \_\_\_\_\_

Notes on Macroinvertebrates: (Predominant Organisms; Other Common Organisms; Diversity Estimate)

---



---



---

Final HMFEI Calculated Score (Sum of All White Box Scores) =

IF Final HMFEI Score is > 19, Then CLASS III PWHH STREAM  
 IF Final HMFEI Score is 7 to 19, Then CLASS II PWHH STREAM  
 IF Final HMFEI Score is < 7, Then CLASS I PWHH STREAM

**PHWH STREAM BIOLOGICAL CHARACTERISTICS FIELD SHEET:**

**1. Fish:**                      Voucher Specimens Retained? (select)                      Time Spent (minutes): \_\_\_\_\_  
 Sample Method \_\_\_\_\_                      Stream Length Assessed (meters) \_\_\_\_\_

Species	Number Caught	Notes

**2. Salamanders:**                      Voucher Specimens Retained? (circle) Y / N                      Time Spent (minutes): \_\_\_\_\_  
 Sample Method \_\_\_\_\_                      Stream Length Assessed (meters) \_\_\_\_\_

Species ( <i>Genus</i> )	# Larvae	# Juveniles/Adults	Total Number
<b>Mountain Dusky</b> ( <i>Desmognathus ochrophaeus</i> )			
<b>Northern Dusky</b> ( <i>Desmognathus fuscus</i> )			
<b>Two-lined</b> ( <i>Eurycea bislineata</i> )			
<b>Long-tailed</b> ( <i>Eurycea longicauda</i> )			
<b>Cave</b> ( <i>Eurycea lucifuga</i> )			
<b>Red</b> ( <i>Pseudotriton ruber</i> )			
<b>Mud</b> ( <i>Pseudotriton montanus</i> )			
<b>Spring</b> ( <i>Gyrinophilus porphyriticus</i> )			
<b>Mole spp.</b> ( <i>Ambystoma spp.</i> )			
<b>Four-toed</b> ( <i>Hemidactylum scutatum</i> )			
<b>Other (name)</b>			
<b>Total</b>			

Notes on Vertebrates: \_\_\_\_\_



### 3. Macroinvertebrate Scoring Sheet:

#### THE HEADWATER MACROINVERTEBRATE FIELD EVALUATION INDEX (HMFEI) SCORING SHEET

Indicate Abundance of Each Taxa Above each White Box.

Record HMFEI Scoring Value Points Within each Box.

For EPT taxa, also indicate the different taxa present.

**Key:** **V** = Very Abundant (> 50); **A** = Abundant (10 -50); **C** = Common (3 -9); **R** = Rare (< 3)

Sessile Animals ( <b>Porifera</b> , <b>Cnidaria</b> , <b>Bryozoa</b> ) (HMFEI pts = 1)	<input type="text"/>	Crayfish ( <b>Decapoda</b> ) (HMFEI pts = 2)	<input type="text"/>	Fishfly Larvae ( <b>Corydalidae</b> ) (HMFEI pts = 3)	<input type="text"/>
Aquatic Worms ( <b>Turbellaria</b> , <b>Hirudinea</b> , <b>Oligochaeta</b> ) (HMFEI pts = 1)	<input type="text"/>	Dragonfly Nymphs ( <b>Anisoptera</b> ) (HMFEI pts = 2)	<input type="text"/>	Water Penny Beetles ( <b>Psephenidae</b> ) (HMFEI pts = 3)	<input type="text"/>
Sow Bugs ( <b>Isopoda</b> ) (HMFEI pts = 1)	<input type="text"/>	Riffle Beetles ( <b>Dryopidae</b> , <b>Elmidae</b> , <b>Ptilodactylidae</b> ) (HMFEI pts = 2)	<input type="text"/>	Crane-fly Larvae ( <b>Tipulidae</b> ) (HMFEI pts = 3)	<input type="text"/>
Scuds ( <b>Amphipoda</b> ) (HMFEI pts = 1)	<input type="text"/>	Larvae of other Flies (enter name in comments) ( <b>Diptera</b> ): (HMFEI pts = 1)	<input type="text"/>	<b>EPT TAXA*</b>	
Water Mites ( <b>Hydracarina</b> ) (HMFEI pts = 1)	<input type="text"/>	Midges ( <b>Chironomidae</b> ) (HMFEI pts = 1)	<input type="text"/>	Total No. EPT Taxa = _____	
Damselfly Nymphs ( <b>Zygoptera</b> ) (HMFEI pts = 1)	<input type="text"/>	Snails ( <b>Gastropoda</b> ) (HMFEI pts = 1)	<input type="text"/>	Mayfly Nymphs ( <b>Ephemeroptera</b> ) Taxa Present: HMFEI pts = _____	<input type="text"/>
Alderfly Larvae ( <b>Sialidae</b> ) (HMFEI pts = 1)	<input type="text"/>	Clams ( <b>Bivalvia</b> ) (HMFEI pts = 1)	<input type="text"/>	No. Taxa (x) 3] _____	
Other Beetles ( <b>Coleoptera</b> ) (HMFEI pts = 1)	<input type="text"/>	Other Taxa :		Stonefly Nymphs ( <b>Plecoptera</b> ) Taxa Present: HMFEI pts = _____	<input type="text"/>
Other Taxa:		Other Taxa:		No. Taxa (x) 3] _____	
Other Taxa:		Other Taxa:		Caddisfly Larvae ( <b>Trichoptera</b> ) Taxa Present: HMFEI pts = _____	<input type="text"/>
Other Taxa:		Other Taxa:		No. Taxa (x) 3] _____	

\*Note: EPT identification based upon Family or Genus level of taxonomy

Voucher Sample ID \_\_\_\_\_

Time Spent (minutes): \_\_\_\_\_

Notes on Macroinvertebrates: (Predominant Organisms; Other Common Organisms; Diversity Estimate)

---



---



---

Final HMFEI Calculated Score (Sum of All White Box Scores) =

IF Final HMFEI Score is > 19, Then CLASS III PHWH STREAM  
 IF Final HMFEI Score is 7 to 19, Then CLASS II PHWH STREAM  
 IF Final HMFEI Score is < 7, Then CLASS I PHWH STREAM

**PHWH STREAM BIOLOGICAL CHARACTERISTICS FIELD SHEET:**

**1. Fish:**                      Voucher Specimens Retained? (select)                      Time Spent (minutes): \_\_\_\_\_  
 Sample Method \_\_\_\_\_                      Stream Length Assessed (meters) \_\_\_\_\_

Species	Number Caught	Notes

**2. Salamanders:**                      Voucher Specimens Retained? (circle) Y / N                      Time Spent (minutes): \_\_\_\_\_  
 Sample Method \_\_\_\_\_                      Stream Length Assessed (meters) \_\_\_\_\_

Species ( <i>Genus</i> )	# Larvae	# Juveniles/Adults	Total Number
<b>Mountain Dusky</b> ( <i>Desmognathus ochrophaeus</i> )			
<b>Northern Dusky</b> ( <i>Desmognathus fuscus</i> )			
<b>Two-lined</b> ( <i>Eurycea bislineata</i> )			
<b>Long-tailed</b> ( <i>Eurycea longicauda</i> )			
<b>Cave</b> ( <i>Eurycea lucifuga</i> )			
<b>Red</b> ( <i>Pseudotriton ruber</i> )			
<b>Mud</b> ( <i>Pseudotriton montanus</i> )			
<b>Spring</b> ( <i>Gyrinophilus porphyriticus</i> )			
<b>Mole spp.</b> ( <i>Ambystoma spp.</i> )			
<b>Four-toed</b> ( <i>Hemidactylium scutatum</i> )			
<b>Other (name)</b>			
<b>Total</b>			

Notes on Vertebrates: \_\_\_\_\_

### 3. Macroinvertebrate Scoring Sheet:

#### THE HEADWATER MACROINVERTEBRATE FIELD EVALUATION INDEX (HMFEI) SCORING SHEET

Indicate Abundance of Each Taxa Above each White Box.

Record HMFEI Scoring Value Points Within each Box.

For EPT taxa, also indicate the different taxa present.

**Key:** **V** = Very Abundant (> 50); **A** = Abundant (10 -50); **C** = Common (3 -9); **R** = Rare (< 3)

Sessile Animals ( <b>Porifera</b> , <b>Cnidaria</b> , <b>Bryozoa</b> ) (HMFEI pts = 1)	<input type="text"/>	Crayfish ( <b>Decapoda</b> ) (HMFEI pts = 2)	<input type="text"/>	Fishfly Larvae ( <b>Corydalidae</b> ) (HMFEI pts = 3)	<input type="text"/>
Aquatic Worms ( <b>Turbellaria</b> , <b>Hirudinea</b> , <b>Oligochaeta</b> ) (HMFEI pts = 1)	<input type="text"/>	Dragonfly Nymphs ( <b>Anisoptera</b> ) (HMFEI pts = 2)	<input type="text"/>	Water Penny Beetles ( <b>Psephenidae</b> ) (HMFEI pts = 3)	<input type="text"/>
Sow Bugs ( <b>Isopoda</b> ) (HMFEI pts = 1)	<input type="text"/>	Riffle Beetles ( <b>Dryopidae</b> , <b>Elmidae</b> , <b>Ptilodactylidae</b> ) (HMFEI pts = 2)	<input type="text"/>	Crane-fly Larvae ( <b>Tipulidae</b> ) (HMFEI pts = 3)	<input type="text"/>
Scuds ( <b>Amphipoda</b> ) (HMFEI pts = 1)	<input type="text"/>	Larvae of other Flies (enter name in comments) ( <b>Diptera</b> ): (HMFEI pts = 1)	<input type="text"/>	<b>EPT TAXA*</b> Total No. EPT Taxa = _____	
Water Mites ( <b>Hydracarina</b> ) (HMFEI pts = 1)	<input type="text"/>	Midges ( <b>Chironomidae</b> ) (HMFEI pts = 1)	<input type="text"/>	Mayfly Nymphs ( <b>Ephemeroptera</b> ) Taxa Present: HMFEI pts = _____ No. Taxa (x) 3]	<input type="text"/>
Damselfly Nymphs ( <b>Zygoptera</b> ) (HMFEI pts = 1)	<input type="text"/>	Snails ( <b>Gastropoda</b> ) (HMFEI pts = 1)	<input type="text"/>		
Alderfly Larvae ( <b>Sialidae</b> ) (HMFEI pts = 1)	<input type="text"/>	Clams ( <b>Bivalvia</b> ) (HMFEI pts = 1)	<input type="text"/>	Stonefly Nymphs ( <b>Plecoptera</b> ) Taxa Present: HMFEI pts = _____ No. Taxa (x) 3]	<input type="text"/>
Other Beetles ( <b>Coleoptera</b> ) (HMFEI pts = 1)	<input type="text"/>	Other Taxa :			
Other Taxa:		Other Taxa:		Caddisfly Larvae ( <b>Trichoptera</b> ) Taxa Present: HMFEI pts = _____ No. Taxa (x) 3]	<input type="text"/>
Other Taxa:		Other Taxa			

\*Note: EPT identification based upon Family or Genus level of taxonomy

Voucher Sample ID \_\_\_\_\_

Time Spent (minutes): \_\_\_\_\_

Notes on Macroinvertebrates: (Predominant Organisms; Other Common Organisms; Diversity Estimate)

---



---



---

Final HMFEI Calculated Score (Sum of All White Box Scores) =

IF Final HMFEI Score is > 19, Then CLASS III PWH STREAM  
 IF Final HMFEI Score is 7 to 19, Then CLASS II PWH STREAM  
 IF Final HMFEI Score is < 7, Then CLASS I PWH STREAM

**PHWH STREAM BIOLOGICAL CHARACTERISTICS FIELD SHEET:**

**1. Fish:**                      Voucher Specimens Retained? (select)                      Time Spent (minutes): \_\_\_\_\_  
 Sample Method \_\_\_\_\_                      Stream Length Assessed (meters) \_\_\_\_\_

Species	Number Caught	Notes

**2. Salamanders:**                      Voucher Specimens Retained? (circle) Y / N                      Time Spent (minutes): \_\_\_\_\_  
 Sample Method \_\_\_\_\_                      Stream Length Assessed (meters) \_\_\_\_\_

Species ( <i>Genus</i> )	# Larvae	# Juveniles/Adults	Total Number
<b>Mountain Dusky</b> ( <i>Desmognathus ochrophaeus</i> )			
<b>Northern Dusky</b> ( <i>Desmognathus fuscus</i> )			
<b>Two-lined</b> ( <i>Eurycea bislineata</i> )			
<b>Long-tailed</b> ( <i>Eurycea longicauda</i> )			
<b>Cave</b> ( <i>Eurycea lucifuga</i> )			
<b>Red</b> ( <i>Pseudotriton ruber</i> )			
<b>Mud</b> ( <i>Pseudotriton montanus</i> )			
<b>Spring</b> ( <i>Gyrinophilus porphyriticus</i> )			
<b>Mole spp.</b> ( <i>Ambystoma spp.</i> )			
<b>Four-toed</b> ( <i>Hemidactylum scutatum</i> )			
<b>Other (name)</b>			
<b>Total</b>			

Notes on Vertebrates: \_\_\_\_\_

### 3. Macroinvertebrate Scoring Sheet:

#### THE HEADWATER MACROINVERTEBRATE FIELD EVALUATION INDEX (HMFEI) SCORING SHEET

Indicate Abundance of Each Taxa Above each White Box.

Record HMFEI Scoring Value Points Within each Box.

For EPT taxa, also indicate the different taxa present.

**Key:** **V** = Very Abundant (> 50); **A** = Abundant (10 -50); **C** = Common (3 -9); **R** = Rare (< 3)

Sessile Animals ( <b>Porifera</b> , <b>Cnidaria</b> , <b>Bryozoa</b> ) (HMFEI pts = 1)	<input type="text"/>	Crayfish ( <b>Decapoda</b> ) (HMFEI pts = 2)	<input type="text"/>	Fishfly Larvae ( <b>Corydalidae</b> ) (HMFEI pts = 3)	<input type="text"/>
Aquatic Worms ( <b>Turbellaria</b> , <b>Hirudinea</b> , <b>Oligochaeta</b> ) (HMFEI pts = 1)	<input type="text"/>	Dragonfly Nymphs ( <b>Anisoptera</b> ) (HMFEI pts = 2)	<input type="text"/>	Water Penny Beetles ( <b>Psephenidae</b> ) (HMFEI pts = 3)	<input type="text"/>
Sow Bugs ( <b>Isopoda</b> ) (HMFEI pts = 1)	<input type="text"/>	Riffle Beetles ( <b>Dryopidae</b> , <b>Elmidae</b> , <b>Ptilodactylidae</b> ) (HMFEI pts = 2)	<input type="text"/>	Crane-fly Larvae ( <b>Tipulidae</b> ) (HMFEI pts = 3)	<input type="text"/>
Scuds ( <b>Amphipoda</b> ) (HMFEI pts = 1)	<input type="text"/>	Larvae of other Flies (enter name in comments) ( <b>Diptera</b> ): (HMFEI pts = 1)	<input type="text"/>	<b>EPT TAXA*</b> Total No. EPT Taxa = _____	
Water Mites ( <b>Hydracarina</b> ) (HMFEI pts = 1)	<input type="text"/>	Midges ( <b>Chironomidae</b> ) (HMFEI pts = 1)	<input type="text"/>	Mayfly Nymphs ( <b>Ephemeroptera</b> ) Taxa Present: HMFEI pts = _____ No. Taxa (x) 3]	<input type="text"/>
Damselfly Nymphs ( <b>Zygoptera</b> ) (HMFEI pts = 1)	<input type="text"/>	Snails ( <b>Gastropoda</b> ) (HMFEI pts = 1)	<input type="text"/>		
Alderfly Larvae ( <b>Sialidae</b> ) (HMFEI pts = 1)	<input type="text"/>	Clams ( <b>Bivalvia</b> ) (HMFEI pts = 1)	<input type="text"/>	Stonefly Nymphs ( <b>Plecoptera</b> ) Taxa Present: HMFEI pts = _____ No. Taxa (x) 3]	<input type="text"/>
Other Beetles ( <b>Coleoptera</b> ) (HMFEI pts = 1)	<input type="text"/>	Other Taxa :			
Other Taxa:		Other Taxa:		Caddisfly Larvae ( <b>Trichoptera</b> ) Taxa Present: HMFEI pts = _____ No. Taxa (x) 3]	<input type="text"/>
Other Taxa:		Other Taxa			

\*Note: EPT identification based upon Family or Genus level of taxonomy

Voucher Sample ID \_\_\_\_\_

Time Spent (minutes): \_\_\_\_\_

Notes on Macroinvertebrates: (Predominant Organisms; Other Common Organisms; Diversity Estimate)

---



---



---

Final HMFEI Calculated Score (Sum of All White Box Scores) =

IF Final HMFEI Score is > 19, Then CLASS III PWH STREAM  
 IF Final HMFEI Score is 7 to 19, Then CLASS II PWH STREAM  
 IF Final HMFEI Score is < 7, Then CLASS I PWH STREAM

**PHWH STREAM BIOLOGICAL CHARACTERISTICS FIELD SHEET:**

**1. Fish:**                      Voucher Specimens Retained? (select)                      Time Spent (minutes): \_\_\_\_\_  
 Sample Method \_\_\_\_\_                      Stream Length Assessed (meters) \_\_\_\_\_

Species	Number Caught	Notes

**2. Salamanders:**                      Voucher Specimens Retained? (circle) Y / N                      Time Spent (minutes): \_\_\_\_\_  
 Sample Method \_\_\_\_\_                      Stream Length Assessed (meters) \_\_\_\_\_

Species ( <i>Genus</i> )	# Larvae	# Juveniles/Adults	Total Number
<b>Mountain Dusky</b> ( <i>Desmognathus ochrophaeus</i> )			
<b>Northern Dusky</b> ( <i>Desmognathus fuscus</i> )			
<b>Two-lined</b> ( <i>Eurycea bislineata</i> )			
<b>Long-tailed</b> ( <i>Eurycea longicauda</i> )			
<b>Cave</b> ( <i>Eurycea lucifuga</i> )			
<b>Red</b> ( <i>Pseudotriton ruber</i> )			
<b>Mud</b> ( <i>Pseudotriton montanus</i> )			
<b>Spring</b> ( <i>Gyrinophilus porphyriticus</i> )			
<b>Mole spp.</b> ( <i>Ambystoma spp.</i> )			
<b>Four-toed</b> ( <i>Hemidactylium scutatum</i> )			
<b>Other (name)</b>			
<b>Total</b>			

Notes on Vertebrates: \_\_\_\_\_

### 3. Macroinvertebrate Scoring Sheet:

#### THE HEADWATER MACROINVERTEBRATE FIELD EVALUATION INDEX (HMFEI) SCORING SHEET

Indicate Abundance of Each Taxa Above each White Box.

Record HMFEI Scoring Value Points Within each Box.

For EPT taxa, also indicate the different taxa present.

**Key: V = Very Abundant (> 50); A = Abundant (10 -50); C = Common (3 -9); R = Rare (< 3)**

Sessile Animals ( <b>Porifera</b> , <b>Cnidaria, Bryozoa</b> ) (HMFEI pts = 1)	<input type="text"/>	Crayfish ( <b>Decapoda</b> ) (HMFEI pts = 2)	<input type="text"/>	Fishfly Larvae ( <b>Corydalidae</b> ) (HMFEI pts = 3)	<input type="text"/>
Aquatic Worms ( <b>Turbellaria, Hirudinea</b> , <b>Oligochaeta</b> ) (HMFEI pts = 1)	<input type="text"/>	Dragonfly Nymphs ( <b>Anisoptera</b> ) (HMFEI pts = 2)	<input type="text"/>	Water Penny Beetles ( <b>Psephenidae</b> ) (HMFEI pts = 3)	<input type="text"/>
Sow Bugs ( <b>Isopoda</b> ) (HMFEI pts = 1)	<input type="text"/>	Riffle Beetles ( <b>Dryopidae</b> , <b>Elmidae, Ptilodactylidae</b> ) (HMFEI pts = 2)	<input type="text"/>	Crane-fly Larvae ( <b>Tipulidae</b> ) (HMFEI pts = 3)	<input type="text"/>
Scuds ( <b>Amphipoda</b> ) (HMFEI pts = 1)	<input type="text"/>	Larvae of other Flies (enter name in comments) ( <b>Diptera</b> ): (HMFEI pts = 1)	<input type="text"/>	<b>EPT TAXA*</b>	
Water Mites ( <b>Hydracarina</b> ) (HMFEI pts = 1)	<input type="text"/>	Midges ( <b>Chironomidae</b> ) (HMFEI pts = 1)	<input type="text"/>	Total No. EPT Taxa = _____	
Damselfly Nymphs ( <b>Zygoptera</b> ) (HMFEI pts = 1)	<input type="text"/>	Snails ( <b>Gastropoda</b> ) (HMFEI pts = 1)	<input type="text"/>	Mayfly Nymphs ( <b>Ephemeroptera</b> ) Taxa Present: HMFEI pts = _____	<input type="text"/>
Alderfly Larvae ( <b>Sialidae</b> ) (HMFEI pts = 1)	<input type="text"/>	Clams ( <b>Bivalvia</b> ) (HMFEI pts = 1)	<input type="text"/>	No. Taxa (x) 3] _____	
Other Beetles ( <b>Coleoptera</b> ) (HMFEI pts = 1)	<input type="text"/>	Other Taxa :		Stonefly Nymphs ( <b>Plecoptera</b> ) Taxa Present: HMFEI pts = _____	<input type="text"/>
Other Taxa:		Other Taxa:		No. Taxa (x) 3] _____	
Other Taxa:		Other Taxa:		Caddisfly Larvae ( <b>Trichoptera</b> ) Taxa Present: HMFEI pts = _____	<input type="text"/>
Other Taxa:		Other Taxa:		No. Taxa (x) 3] _____	

\*Note: EPT identification based upon Family or Genus level of taxonomy

Voucher Sample ID \_\_\_\_\_

Time Spent (minutes): \_\_\_\_\_

Notes on Macroinvertebrates: (Predominant Organisms; Other Common Organisms; Diversity Estimate)

---



---



---

Final HMFEI Calculated Score (Sum of All White Box Scores) =

IF Final HMFEI Score is > 19, Then CLASS III PWHH STREAM  
 IF Final HMFEI Score is 7 to 19, Then CLASS II PWHH STREAM  
 IF Final HMFEI Score is < 7, Then CLASS I PWHH STREAM

**PHWH STREAM BIOLOGICAL CHARACTERISTICS FIELD SHEET:**

**1. Fish:**                      Voucher Specimens Retained? (select)                      Time Spent (minutes): \_\_\_\_\_  
 Sample Method \_\_\_\_\_                      Stream Length Assessed (meters) \_\_\_\_\_

Species	Number Caught	Notes

**2. Salamanders:**                      Voucher Specimens Retained? (circle) Y / N                      Time Spent (minutes): \_\_\_\_\_  
 Sample Method \_\_\_\_\_                      Stream Length Assessed (meters) \_\_\_\_\_

Species ( <i>Genus</i> )	# Larvae	# Juveniles/Adults	Total Number
<b>Mountain Dusky</b> ( <i>Desmognathus ochrophaeus</i> )			
<b>Northern Dusky</b> ( <i>Desmognathus fuscus</i> )			
<b>Two-lined</b> ( <i>Eurycea bislineata</i> )			
<b>Long-tailed</b> ( <i>Eurycea longicauda</i> )			
<b>Cave</b> ( <i>Eurycea lucifuga</i> )			
<b>Red</b> ( <i>Pseudotriton ruber</i> )			
<b>Mud</b> ( <i>Pseudotriton montanus</i> )			
<b>Spring</b> ( <i>Gyrinophilus porphyriticus</i> )			
<b>Mole spp.</b> ( <i>Ambystoma spp.</i> )			
<b>Four-toed</b> ( <i>Hemidactylum scutatum</i> )			
<b>Other (name)</b>			
<b>Total</b>			

Notes on Vertebrates: \_\_\_\_\_



### 3. Macroinvertebrate Scoring Sheet:

#### THE HEADWATER MACROINVERTEBRATE FIELD EVALUATION INDEX (HMFEI) SCORING SHEET

Indicate Abundance of Each Taxa Above each White Box.

Record HMFEI Scoring Value Points Within each Box.

For EPT taxa, also indicate the different taxa present.

**Key:** **V** = Very Abundant (> 50); **A** = Abundant (10 -50); **C** = Common (3 -9); **R** = Rare (< 3)

Sessile Animals ( <b>Porifera</b> , <b>Cnidaria</b> , <b>Bryozoa</b> ) (HMFEI pts = 1)	<input type="text"/>	Crayfish ( <b>Decapoda</b> ) (HMFEI pts = 2)	<input type="text"/>	Fishfly Larvae ( <b>Corydalidae</b> ) (HMFEI pts = 3)	<input type="text"/>
Aquatic Worms ( <b>Turbellaria</b> , <b>Hirudinea</b> , <b>Oligochaeta</b> ) (HMFEI pts = 1)	<input type="text"/>	Dragonfly Nymphs ( <b>Anisoptera</b> ) (HMFEI pts = 2)	<input type="text"/>	Water Penny Beetles ( <b>Psephenidae</b> ) (HMFEI pts = 3)	<input type="text"/>
Sow Bugs ( <b>Isopoda</b> ) (HMFEI pts = 1)	<input type="text"/>	Riffle Beetles ( <b>Dryopidae</b> , <b>Elmidae</b> , <b>Ptilodactylidae</b> ) (HMFEI pts = 2)	<input type="text"/>	Crane-fly Larvae ( <b>Tipulidae</b> ) (HMFEI pts = 3)	<input type="text"/>
Scuds ( <b>Amphipoda</b> ) (HMFEI pts = 1)	<input type="text"/>	Larvae of other Flies (enter name in comments) ( <b>Diptera</b> ): (HMFEI pts = 1)	<input type="text"/>	<b>EPT TAXA*</b>	
Water Mites ( <b>Hydracarina</b> ) (HMFEI pts = 1)	<input type="text"/>	Midges ( <b>Chironomidae</b> ) (HMFEI pts = 1)	<input type="text"/>	Total No. EPT Taxa = _____	
Damselfly Nymphs ( <b>Zygoptera</b> ) (HMFEI pts = 1)	<input type="text"/>	Snails ( <b>Gastropoda</b> ) (HMFEI pts = 1)	<input type="text"/>	Mayfly Nymphs ( <b>Ephemeroptera</b> ) Taxa Present: HMFEI pts = _____	<input type="text"/>
Alderfly Larvae ( <b>Sialidae</b> ) (HMFEI pts = 1)	<input type="text"/>	Clams ( <b>Bivalvia</b> ) (HMFEI pts = 1)	<input type="text"/>	No. Taxa (x) 3] _____	
Other Beetles ( <b>Coleoptera</b> ) (HMFEI pts = 1)	<input type="text"/>	Other Taxa :		Stonefly Nymphs ( <b>Plecoptera</b> ) Taxa Present: HMFEI pts = _____	<input type="text"/>
Other Taxa:		Other Taxa:		No. Taxa (x) 3] _____	
Other Taxa:		Other Taxa:		Caddisfly Larvae ( <b>Trichoptera</b> ) Taxa Present: HMFEI pts = _____	<input type="text"/>
Other Taxa:		Other Taxa:		No. Taxa (x) 3] _____	

\*Note: EPT identification based upon Family or Genus level of taxonomy

Voucher Sample ID \_\_\_\_\_

Time Spent (minutes): \_\_\_\_\_

Notes on Macroinvertebrates: (Predominant Organisms; Other Common Organisms; Diversity Estimate)

---



---



---

Final HMFEI Calculated Score (Sum of All White Box Scores) =

IF Final HMFEI Score is > 19, Then CLASS III PHWH STREAM  
 IF Final HMFEI Score is 7 to 19, Then CLASS II PHWH STREAM  
 IF Final HMFEI Score is < 7, Then CLASS I PHWH STREAM

**PHWH STREAM BIOLOGICAL CHARACTERISTICS FIELD SHEET:**

**1. Fish:**                      Voucher Specimens Retained? (select)                      Time Spent (minutes): \_\_\_\_\_  
 Sample Method \_\_\_\_\_                      Stream Length Assessed (meters) \_\_\_\_\_

Species	Number Caught	Notes

**2. Salamanders:**                      Voucher Specimens Retained? (circle) Y / N                      Time Spent (minutes): \_\_\_\_\_  
 Sample Method \_\_\_\_\_                      Stream Length Assessed (meters) \_\_\_\_\_

Species ( <i>Genus</i> )	# Larvae	# Juveniles/Adults	Total Number
<b>Mountain Dusky</b> ( <i>Desmognathus ochrophaeus</i> )			
<b>Northern Dusky</b> ( <i>Desmognathus fuscus</i> )			
<b>Two-lined</b> ( <i>Eurycea bislineata</i> )			
<b>Long-tailed</b> ( <i>Eurycea longicauda</i> )			
<b>Cave</b> ( <i>Eurycea lucifuga</i> )			
<b>Red</b> ( <i>Pseudotriton ruber</i> )			
<b>Mud</b> ( <i>Pseudotriton montanus</i> )			
<b>Spring</b> ( <i>Gyrinophilus porphyriticus</i> )			
<b>Mole spp.</b> ( <i>Ambystoma spp.</i> )			
<b>Four-toed</b> ( <i>Hemidactylum scutatum</i> )			
<b>Other (name)</b>			
<b>Total</b>			

Notes on Vertebrates: \_\_\_\_\_

### 3. Macroinvertebrate Scoring Sheet:

#### THE HEADWATER MACROINVERTEBRATE FIELD EVALUATION INDEX (HMFEI) SCORING SHEET

Indicate Abundance of Each Taxa Above each White Box.

Record HMFEI Scoring Value Points Within each Box.

For EPT taxa, also indicate the different taxa present.

**Key:** **V** = Very Abundant (> 50); **A** = Abundant (10 -50); **C** = Common (3 -9); **R** = Rare (< 3)

Sessile Animals ( <b>Porifera</b> , <b>Cnidaria</b> , <b>Bryozoa</b> ) (HMFEI pts = 1)	<input type="text"/>	Crayfish ( <b>Decapoda</b> ) (HMFEI pts = 2)	<input type="text"/>	Fishfly Larvae ( <b>Corydalidae</b> ) (HMFEI pts = 3)	<input type="text"/>
Aquatic Worms ( <b>Turbellaria</b> , <b>Hirudinea</b> , <b>Oligochaeta</b> ) (HMFEI pts = 1)	<input type="text"/>	Dragonfly Nymphs ( <b>Anisoptera</b> ) (HMFEI pts = 2)	<input type="text"/>	Water Penny Beetles ( <b>Psephenidae</b> ) (HMFEI pts = 3)	<input type="text"/>
Sow Bugs ( <b>Isopoda</b> ) (HMFEI pts = 1)	<input type="text"/>	Riffle Beetles ( <b>Dryopidae</b> , <b>Elmidae</b> , <b>Ptilodactylidae</b> ) (HMFEI pts = 2)	<input type="text"/>	Crane-fly Larvae ( <b>Tipulidae</b> ) (HMFEI pts = 3)	<input type="text"/>
Scuds ( <b>Amphipoda</b> ) (HMFEI pts = 1)	<input type="text"/>	Larvae of other Flies (enter name in comments) ( <b>Diptera</b> ): (HMFEI pts = 1)	<input type="text"/>	<b>EPT TAXA*</b>	
Water Mites ( <b>Hydracarina</b> ) (HMFEI pts = 1)	<input type="text"/>	Midges ( <b>Chironomidae</b> ) (HMFEI pts = 1)	<input type="text"/>	Total No. EPT Taxa = _____	
Damselfly Nymphs ( <b>Zygoptera</b> ) (HMFEI pts = 1)	<input type="text"/>	Snails ( <b>Gastropoda</b> ) (HMFEI pts = 1)	<input type="text"/>	Mayfly Nymphs ( <b>Ephemeroptera</b> ) Taxa Present: HMFEI pts = _____	<input type="text"/>
Alderfly Larvae ( <b>Sialidae</b> ) (HMFEI pts = 1)	<input type="text"/>	Clams ( <b>Bivalvia</b> ) (HMFEI pts = 1)	<input type="text"/>	No. Taxa (x) 3] _____	
Other Beetles ( <b>Coleoptera</b> ) (HMFEI pts = 1)	<input type="text"/>	Other Taxa :		Stonefly Nymphs ( <b>Plecoptera</b> ) Taxa Present: HMFEI pts = _____	<input type="text"/>
Other Taxa:		Other Taxa:		No. Taxa (x) 3] _____	
Other Taxa:		Other Taxa:		Caddisfly Larvae ( <b>Trichoptera</b> ) Taxa Present: HMFEI pts = _____	<input type="text"/>
Other Taxa:		Other Taxa:		No. Taxa (x) 3] _____	

\*Note: EPT identification based upon Family or Genus level of taxonomy

Voucher Sample ID \_\_\_\_\_

Time Spent (minutes): \_\_\_\_\_

Notes on Macroinvertebrates: (Predominant Organisms; Other Common Organisms; Diversity Estimate)

---



---



---

Final HMFEI Calculated Score (Sum of All White Box Scores) =

IF Final HMFEI Score is > 19, Then CLASS III PWH STREAM  
 IF Final HMFEI Score is 7 to 19, Then CLASS II PWH STREAM  
 IF Final HMFEI Score is < 7, Then CLASS I PWH STREAM



SITE NAME/LOCATION \_\_\_\_\_  
 \_\_\_\_\_ SITE NUMBER \_\_\_\_\_ RIVER BASIN \_\_\_\_\_ DRAINAGE AREA (mi<sup>2</sup>) \_\_\_\_\_  
 LENGTH OF STREAM REACH (ft) \_\_\_\_\_ LAT. \_\_\_\_\_ LONG. \_\_\_\_\_ RIVER CODE \_\_\_\_\_ RIVER MILE \_\_\_\_\_  
 DATE \_\_\_\_\_ SCORER \_\_\_\_\_ COMMENTS \_\_\_\_\_

**NOTE: Complete All Items On This Form - Refer to "Field Evaluation Manual for Ohio's PWH Streams" for Instructions**

**STREAM CHANNEL MODIFICATIONS:**  NONE / NATURAL CHANNEL  RECOVERED  RECOVERING  RECENT OR NO RECOVERY

**1. SUBSTRATE (Estimate percent of every type of substrate present. Check ONLY two predominant substrate TYPE boxes (Max of 32). Add total number of significant substrate types found (Max of 8). Final metric score is sum of boxes A & B.)**

TYPE	PERCENT	TYPE	PERCENT
<input type="checkbox"/> <input type="checkbox"/> BLDR SLABS [16 pts]	_____	<input type="checkbox"/> <input type="checkbox"/> SILT [3 pt]	_____
<input type="checkbox"/> <input type="checkbox"/> BOULDER (>256 mm) [16 pts]	_____	<input type="checkbox"/> <input type="checkbox"/> LEAF PACK/WOODY DEBRIS [3 pts]	_____
<input type="checkbox"/> <input type="checkbox"/> BEDROCK [16 pt]	_____	<input type="checkbox"/> <input type="checkbox"/> FINE DETRITUS [3 pts]	_____
<input type="checkbox"/> <input type="checkbox"/> COBBLE (65-256 mm) [12 pts]	_____	<input type="checkbox"/> <input type="checkbox"/> CLAY or HARDPAN [0 pt]	_____
<input type="checkbox"/> <input type="checkbox"/> GRAVEL (2-64 mm) [9 pts]	_____	<input type="checkbox"/> <input type="checkbox"/> MUCK [0 pts]	_____
<input type="checkbox"/> <input type="checkbox"/> SAND (<2 mm) [6 pts]	_____	<input type="checkbox"/> <input type="checkbox"/> ARTIFICIAL [3 pts]	_____

Total of Percentages of Bldr Slabs, Boulder, Cobble, Bedrock **(A)** \_\_\_\_\_

Substrate Percentage Check **(B)** \_\_\_\_\_

**SCORE OF TWO MOST PREDOMINATE SUBSTRATE TYPES:** \_\_\_\_\_ **TOTAL NUMBER OF SUBSTRATE TYPES:** \_\_\_\_\_

---

**2. Maximum Pool Depth (Measure the maximum pool depth within the 61 meter (200 ft) evaluation reach at the time of evaluation. Avoid plunge pools from road culverts or storm water pipes) (Check ONLY one box):**

<input type="checkbox"/> > 30 centimeters [20 pts]	<input type="checkbox"/> > 5 cm - 10 cm [15 pts]
<input type="checkbox"/> > 22.5 - 30 cm [30 pts]	<input type="checkbox"/> < 5 cm [5 pts]
<input type="checkbox"/> > 10 - 22.5 cm [25 pts]	<input type="checkbox"/> NO WATER OR MOIST CHANNEL [0 pts]

**COMMENTS** \_\_\_\_\_ **MAXIMUM POOL DEPTH (centimeters):** \_\_\_\_\_

---

**3. BANK FULL WIDTH (Measured as the average of 3-4 measurements) (Check ONLY one box):**

<input type="checkbox"/> > 4.0 meters (> 13') [30 pts]	<input type="checkbox"/> > 1.0 m - 1.5 m (> 3' 3" - 4' 8") [15 pts]
<input type="checkbox"/> > 3.0 m - 4.0 m (> 9' 7" - 13') [25 pts]	<input type="checkbox"/> ≤ 1.0 m (≤ 3' 3") [5 pts]
<input type="checkbox"/> > 1.5 m - 3.0 m (> 9' 7" - 4' 8") [20 pts]	

**COMMENTS** \_\_\_\_\_ **AVERAGE BANKFULL WIDTH (meters):** \_\_\_\_\_

**HHEI Metric Points**

Substrate Max = 40

\_\_\_\_\_

A + B

Pool Depth Max = 30

\_\_\_\_\_

Bankfull Width Max=30

\_\_\_\_\_

**This information must also be completed**

**RIPARIAN ZONE AND FLOODPLAIN QUALITY** ☆NOTE: River Left (L) and Right (R) as looking downstream ☆

RIPARIAN WIDTH		FLOODPLAIN QUALITY	
L	R	L	R
<input type="checkbox"/> <input type="checkbox"/>	(Per Bank)	<input type="checkbox"/> <input type="checkbox"/>	(Most Predominant per Bank)
<input type="checkbox"/> <input type="checkbox"/>	Wide >10m	<input type="checkbox"/> <input type="checkbox"/>	Mature Forest, Wetland
<input type="checkbox"/> <input type="checkbox"/>	Moderate 5-10m	<input type="checkbox"/> <input type="checkbox"/>	Immature Forest, Shrub or Old Field
<input type="checkbox"/> <input type="checkbox"/>	Narrow <5m	<input type="checkbox"/> <input type="checkbox"/>	Residential, Park, New Field
<input type="checkbox"/> <input type="checkbox"/>	None	<input type="checkbox"/> <input type="checkbox"/>	Fenced Pasture
<input type="checkbox"/> <input type="checkbox"/>		<input type="checkbox"/> <input type="checkbox"/>	Conservation Tillage
<input type="checkbox"/> <input type="checkbox"/>		<input type="checkbox"/> <input type="checkbox"/>	Urban or Industrial
<input type="checkbox"/> <input type="checkbox"/>		<input type="checkbox"/> <input type="checkbox"/>	Open Pasture, Row Crop
<input type="checkbox"/> <input type="checkbox"/>		<input type="checkbox"/> <input type="checkbox"/>	Mining or Construction

**COMMENTS** \_\_\_\_\_

**FLOW REGIME (At Time of Evaluation) (Check ONLY one box):**

<input type="checkbox"/> Stream Flowing	<input type="checkbox"/> Moist Channel, isolated pools, no flow (Intermittent)
<input type="checkbox"/> Subsurface flow with isolated pools (Interstitial)	<input type="checkbox"/> Dry channel, no water (Ephemeral)

**COMMENTS** \_\_\_\_\_

**SINUOSITY (Number of bends per 61 m (200 ft) of channel) (Check ONLY one box):**

<input type="checkbox"/> None	<input type="checkbox"/> 1.0	<input type="checkbox"/> 2.0	<input type="checkbox"/> 3.0
<input type="checkbox"/> 0.5	<input type="checkbox"/> 1.5	<input type="checkbox"/> 2.5	<input type="checkbox"/> >3

**STREAM GRADIENT ESTIMATE**

Flat (0.5 ft/100 ft)  Flat to Moderate  Moderate (2 ft/100 ft)  Moderate to Severe  Severe (10 ft/100 ft)

**ADDITIONAL STREAM INFORMATION (This Information Must Also be Completed):**

**QHEI PERFORMED?** -  Yes  No QHEI Score \_\_\_\_\_ (If Yes, Attach Completed QHEI Form)

**DOWNSTREAM DESIGNATED USE(S)**

- WWH Name: \_\_\_\_\_ Distance from Evaluated Stream \_\_\_\_\_
- CWH Name: \_\_\_\_\_ Distance from Evaluated Stream \_\_\_\_\_
- EWH Name: \_\_\_\_\_ Distance from Evaluated Stream \_\_\_\_\_

**MAPPING: ATTACH COPIES OF MAPS, INCLUDING THE ENTIRE WATERSHED AREA. CLEARLY MARK THE SITE LOCATION**

USGS Quadrangle Name: \_\_\_\_\_ NRCS Soil Map Page: \_\_\_\_\_ NRCS Soil Map Stream Order \_\_\_\_\_

County: \_\_\_\_\_ Township / City: \_\_\_\_\_

**MISCELLANEOUS**

Base Flow Conditions? (Y/N): \_\_\_\_\_ Date of last precipitation: \_\_\_\_\_ Quantity: \_\_\_\_\_

Photograph Information: \_\_\_\_\_

Elevated Turbidity? (Y/N): \_\_\_\_\_ Canopy (% open): \_\_\_\_\_

Were samples collected for water chemistry? (Y/N): \_\_\_\_\_ (Note lab sample no. or id. and attach results) Lab Number: \_\_\_\_\_

Field Measures: Temp (°C) \_\_\_\_\_ Dissolved Oxygen (mg/l) \_\_\_\_\_ pH (S.U.) \_\_\_\_\_ Conductivity (µmhos/cm) \_\_\_\_\_

Is the sampling reach representative of the stream (Y/N) \_\_\_\_\_ If not, please explain: \_\_\_\_\_

\_\_\_\_\_

Additional comments/description of pollution impacts: \_\_\_\_\_

\_\_\_\_\_

**BIOTIC EVALUATION**

Performed? (Y/N): \_\_\_\_\_ (If Yes, Record all observations. Voucher collections optional. NOTE: all voucher samples must be labeled with the site ID number. Include appropriate field data sheets from the Primary Headwater Habitat Assessment Manual)

Fish Observed? (Y/N) \_\_\_\_\_ Voucher? (Y/N) \_\_\_\_\_ Salamanders Observed? (Y/N) \_\_\_\_\_ Voucher? (Y/N) \_\_\_\_\_

Frogs or Tadpoles Observed? (Y/N) \_\_\_\_\_ Voucher? (Y/N) \_\_\_\_\_ Aquatic Macroinvertebrates Observed? (Y/N) \_\_\_\_\_ Voucher? (Y/N) \_\_\_\_\_

Comments Regarding Biology: \_\_\_\_\_

\_\_\_\_\_

\_\_\_\_\_

**DRAWING AND NARRATIVE DESCRIPTION OF STREAM REACH (This must be completed):**

Include important landmarks and other features of interest for site evaluation and a narrative description of the stream's location

FLOW 



# Primary Headwater Habitat Evaluation Form

HHEI Score (sum of metrics 1, 2, 3) :

SITE NAME/LOCATION \_\_\_\_\_

\_\_\_\_\_ SITE NUMBER \_\_\_\_\_ RIVER BASIN \_\_\_\_\_ DRAINAGE AREA (mi<sup>2</sup>) \_\_\_\_\_

LENGTH OF STREAM REACH (ft) \_\_\_\_\_ LAT. \_\_\_\_\_ LONG. \_\_\_\_\_ RIVER CODE \_\_\_\_\_ RIVER MILE \_\_\_\_\_

DATE \_\_\_\_\_ SCORER \_\_\_\_\_ COMMENTS \_\_\_\_\_

**NOTE: Complete All Items On This Form - Refer to "Field Evaluation Manual for Ohio's PWH Streams" for Instructions**

**STREAM CHANNEL MODIFICATIONS:**

NONE / NATURAL CHANNEL  RECOVERED  RECOVERING  RECENT OR NO RECOVERY

**1. SUBSTRATE (Estimate percent of every type of substrate present. Check ONLY two predominant substrate TYPE boxes (Max of 32). Add total number of significant substrate types found (Max of 8). Final metric score is sum of boxes A & B.**

TYPE	PERCENT	TYPE	PERCENT
<input type="checkbox"/> <input type="checkbox"/> BLDR SLABS [16 pts]	_____	<input type="checkbox"/> <input type="checkbox"/> SILT [3 pt]	_____
<input type="checkbox"/> <input type="checkbox"/> BOULDER (>256 mm) [16 pts]	_____	<input type="checkbox"/> <input type="checkbox"/> LEAF PACK/WOODY DEBRIS [3 pts]	_____
<input type="checkbox"/> <input type="checkbox"/> BEDROCK [16 pt]	_____	<input type="checkbox"/> <input type="checkbox"/> FINE DETRITUS [3 pts]	_____
<input type="checkbox"/> <input type="checkbox"/> COBBLE (65-256 mm) [12 pts]	_____	<input type="checkbox"/> <input type="checkbox"/> CLAY or HARDPAN [0 pt]	_____
<input type="checkbox"/> <input type="checkbox"/> GRAVEL (2-64 mm) [9 pts]	_____	<input type="checkbox"/> <input type="checkbox"/> MUCK [0 pts]	_____
<input type="checkbox"/> <input type="checkbox"/> SAND (<2 mm) [6 pts]	_____	<input type="checkbox"/> <input type="checkbox"/> ARTIFICIAL [3 pts]	_____

Total of Percentages of Bldr Slabs, Boulder, Cobble, Bedrock \_\_\_\_\_

(A)

Substrate Percentage Check

(B)

SCORE OF TWO MOST PREDOMINATE SUBSTRATE TYPES:

TOTAL NUMBER OF SUBSTRATE TYPES:

**HHEI Metric Points**

Substrate Max = 40

A + B

**2. Maximum Pool Depth (Measure the maximum pool depth within the 61 meter (200 ft) evaluation reach at the time of evaluation. Avoid plunge pools from road culverts or storm water pipes) (Check ONLY one box):**

<input type="checkbox"/> > 30 centimeters [20 pts]	<input type="checkbox"/> > 5 cm - 10 cm [15 pts]
<input type="checkbox"/> > 22.5 - 30 cm [30 pts]	<input type="checkbox"/> < 5 cm [5 pts]
<input type="checkbox"/> > 10 - 22.5 cm [25 pts]	<input type="checkbox"/> NO WATER OR MOIST CHANNEL [0 pts]

COMMENTS \_\_\_\_\_ MAXIMUM POOL DEPTH (centimeters):

Pool Depth Max = 30

**3. BANK FULL WIDTH (Measured as the average of 3-4 measurements) (Check ONLY one box):**

<input type="checkbox"/> > 4.0 meters (> 13') [30 pts]	<input type="checkbox"/> > 1.0 m - 1.5 m (> 3' 3" - 4' 8") [15 pts]
<input type="checkbox"/> > 3.0 m - 4.0 m (> 9' 7" - 13') [25 pts]	<input type="checkbox"/> ≤ 1.0 m (≤ 3' 3") [5 pts]
<input type="checkbox"/> > 1.5 m - 3.0 m (> 9' 7" - 4' 8") [20 pts]	

COMMENTS \_\_\_\_\_ AVERAGE BANKFULL WIDTH (meters):

Bankfull Width Max=30

**This information must also be completed**

**RIPARIAN ZONE AND FLOODPLAIN QUALITY** ☆NOTE: River Left (L) and Right (R) as looking downstream ☆

RIPARIAN WIDTH

L	R	(Per Bank)
<input type="checkbox"/>	<input type="checkbox"/>	Wide >10m
<input type="checkbox"/>	<input type="checkbox"/>	Moderate 5-10m
<input type="checkbox"/>	<input type="checkbox"/>	Narrow <5m
<input type="checkbox"/>	<input type="checkbox"/>	None

FLOODPLAIN QUALITY

L	R	(Most Predominant per Bank)
<input type="checkbox"/>	<input type="checkbox"/>	Mature Forest, Wetland
<input type="checkbox"/>	<input type="checkbox"/>	Immature Forest, Shrub or Old Field
<input type="checkbox"/>	<input type="checkbox"/>	Residential, Park, New Field
<input type="checkbox"/>	<input type="checkbox"/>	Fenced Pasture

L	R	
<input type="checkbox"/>	<input type="checkbox"/>	Conservation Tillage
<input type="checkbox"/>	<input type="checkbox"/>	Urban or Industrial
<input type="checkbox"/>	<input type="checkbox"/>	Open Pasture, Row Crop
<input type="checkbox"/>	<input type="checkbox"/>	Mining or Construction

COMMENTS \_\_\_\_\_

**FLOW REGIME (At Time of Evaluation) (Check ONLY one box):**

<input type="checkbox"/> Stream Flowing	<input type="checkbox"/> Moist Channel, isolated pools, no flow (Intermittent)
<input type="checkbox"/> Subsurface flow with isolated pools (Interstitial)	<input type="checkbox"/> Dry channel, no water (Ephemeral)

COMMENTS \_\_\_\_\_

**SINUOSITY (Number of bends per 61 m (200 ft) of channel) (Check ONLY one box):**

<input type="checkbox"/> None	<input type="checkbox"/> 1.0	<input type="checkbox"/> 2.0	<input type="checkbox"/> 3.0
<input type="checkbox"/> 0.5	<input type="checkbox"/> 1.5	<input type="checkbox"/> 2.5	<input type="checkbox"/> >3

**STREAM GRADIENT ESTIMATE**

Flat (0.5 ft/100 ft)  Flat to Moderate  Moderate (2 ft/100 ft)  Moderate to Severe  Severe (10 ft/100 ft)

**ADDITIONAL STREAM INFORMATION (This Information Must Also be Completed):**

**QHEI PERFORMED?** -  Yes  No QHEI Score \_\_\_\_\_ (If Yes, Attach Completed QHEI Form)

**DOWNSTREAM DESIGNATED USE(S)**

- WWH Name: \_\_\_\_\_ Distance from Evaluated Stream \_\_\_\_\_
- CWH Name: \_\_\_\_\_ Distance from Evaluated Stream \_\_\_\_\_
- EWH Name: \_\_\_\_\_ Distance from Evaluated Stream \_\_\_\_\_

**MAPPING: ATTACH COPIES OF MAPS, INCLUDING THE ENTIRE WATERSHED AREA. CLEARLY MARK THE SITE LOCATION**

USGS Quadrangle Name: \_\_\_\_\_ NRCS Soil Map Page: \_\_\_\_\_ NRCS Soil Map Stream Order \_\_\_\_\_

County: \_\_\_\_\_ Township / City: \_\_\_\_\_

**MISCELLANEOUS**

Base Flow Conditions? (Y/N): \_\_\_\_\_ Date of last precipitation: \_\_\_\_\_ Quantity: \_\_\_\_\_

Photograph Information: \_\_\_\_\_

Elevated Turbidity? (Y/N): \_\_\_\_\_ Canopy (% open): \_\_\_\_\_

Were samples collected for water chemistry? (Y/N): \_\_\_\_\_ (Note lab sample no. or id. and attach results) Lab Number: \_\_\_\_\_

Field Measures: Temp (°C) \_\_\_\_\_ Dissolved Oxygen (mg/l) \_\_\_\_\_ pH (S.U.) \_\_\_\_\_ Conductivity (µmhos/cm) \_\_\_\_\_

Is the sampling reach representative of the stream (Y/N) \_\_\_\_\_ If not, please explain: \_\_\_\_\_

Additional comments/description of pollution impacts: \_\_\_\_\_

**BIOTIC EVALUATION**

Performed? (Y/N): \_\_\_\_\_ (If Yes, Record all observations. Voucher collections optional. NOTE: all voucher samples must be labeled with the site ID number. Include appropriate field data sheets from the Primary Headwater Habitat Assessment Manual)

Fish Observed? (Y/N) \_\_\_\_\_ Voucher? (Y/N) \_\_\_\_\_ Salamanders Observed? (Y/N) \_\_\_\_\_ Voucher? (Y/N) \_\_\_\_\_  
Frogs or Tadpoles Observed? (Y/N) \_\_\_\_\_ Voucher? (Y/N) \_\_\_\_\_ Aquatic Macroinvertebrates Observed? (Y/N) \_\_\_\_\_ Voucher? (Y/N) \_\_\_\_\_

Comments Regarding Biology: \_\_\_\_\_

**DRAWING AND NARRATIVE DESCRIPTION OF STREAM REACH (This must be completed):**

Include important landmarks and other features of interest for site evaluation and a narrative description of the stream's location

FLOW 

SITE NAME/LOCATION \_\_\_\_\_  
 \_\_\_\_\_ SITE NUMBER \_\_\_\_\_ RIVER BASIN \_\_\_\_\_ DRAINAGE AREA (mi<sup>2</sup>) \_\_\_\_\_  
 LENGTH OF STREAM REACH (ft) \_\_\_\_\_ LAT. \_\_\_\_\_ LONG. \_\_\_\_\_ RIVER CODE \_\_\_\_\_ RIVER MILE \_\_\_\_\_  
 DATE \_\_\_\_\_ SCORER \_\_\_\_\_ COMMENTS \_\_\_\_\_

**NOTE: Complete All Items On This Form - Refer to "Field Evaluation Manual for Ohio's PWH Streams" for Instructions**

**STREAM CHANNEL MODIFICATIONS:**     NONE / NATURAL CHANNEL     RECOVERED     RECOVERING     RECENT OR NO RECOVERY

**1. SUBSTRATE (Estimate percent of every type of substrate present. Check ONLY two predominant substrate TYPE boxes (Max of 32). Add total number of significant substrate types found (Max of 8). Final metric score is sum of boxes A & B.)**

TYPE	PERCENT	TYPE	PERCENT
<input type="checkbox"/> <input type="checkbox"/> BLDR SLABS [16 pts]	_____	<input type="checkbox"/> <input type="checkbox"/> SILT [3 pt]	_____
<input type="checkbox"/> <input type="checkbox"/> BOULDER (>256 mm) [16 pts]	_____	<input type="checkbox"/> <input type="checkbox"/> LEAF PACK/WOODY DEBRIS [3 pts]	_____
<input type="checkbox"/> <input type="checkbox"/> BEDROCK [16 pt]	_____	<input type="checkbox"/> <input type="checkbox"/> FINE DETRITUS [3 pts]	_____
<input type="checkbox"/> <input type="checkbox"/> COBBLE (65-256 mm) [12 pts]	_____	<input type="checkbox"/> <input type="checkbox"/> CLAY or HARDPAN [0 pt]	_____
<input type="checkbox"/> <input type="checkbox"/> GRAVEL (2-64 mm) [9 pts]	_____	<input type="checkbox"/> <input type="checkbox"/> MUCK [0 pts]	_____
<input type="checkbox"/> <input type="checkbox"/> SAND (<2 mm) [6 pts]	_____	<input type="checkbox"/> <input type="checkbox"/> ARTIFICIAL [3 pts]	_____

Total of Percentages of Bldr Slabs, Boulder, Cobble, Bedrock **(A)** Substrate Percentage Check **(B)**

**SCORE OF TWO MOST PREDOMINATE SUBSTRATE TYPES:**    
 **TOTAL NUMBER OF SUBSTRATE TYPES:**

**2. Maximum Pool Depth (Measure the maximum pool depth within the 61 meter (200 ft) evaluation reach at the time of evaluation. Avoid plunge pools from road culverts or storm water pipes) (Check ONLY one box):**

<input type="checkbox"/> > 30 centimeters [20 pts]	<input type="checkbox"/> > 5 cm - 10 cm [15 pts]
<input type="checkbox"/> > 22.5 - 30 cm [30 pts]	<input type="checkbox"/> < 5 cm [5 pts]
<input type="checkbox"/> > 10 - 22.5 cm [25 pts]	<input type="checkbox"/> NO WATER OR MOIST CHANNEL [0 pts]

COMMENTS \_\_\_\_\_ **MAXIMUM POOL DEPTH (centimeters):**

**3. BANK FULL WIDTH (Measured as the average of 3-4 measurements) (Check ONLY one box):**

<input type="checkbox"/> > 4.0 meters (> 13') [30 pts]	<input type="checkbox"/> > 1.0 m - 1.5 m (> 3' 3" - 4' 8") [15 pts]
<input type="checkbox"/> > 3.0 m - 4.0 m (> 9' 7" - 13') [25 pts]	<input type="checkbox"/> ≤ 1.0 m (≤ 3' 3") [5 pts]
<input type="checkbox"/> > 1.5 m - 3.0 m (> 9' 7" - 4' 8") [20 pts]	

COMMENTS \_\_\_\_\_ **AVERAGE BANKFULL WIDTH (meters):**

**HHEI Metric Points**

Substrate Max = 40

A + B

---

Pool Depth Max = 30

---

Bankfull Width Max=30

**This information must also be completed**

**RIPARIAN ZONE AND FLOODPLAIN QUALITY**    ☆NOTE: River Left (L) and Right (R) as looking downstream ☆

<u>RIPARIAN WIDTH</u>		<u>FLOODPLAIN QUALITY</u>	
L	R	L	R
<input type="checkbox"/>	<input type="checkbox"/>	<input type="checkbox"/>	<input type="checkbox"/>
(Per Bank)		(Most Predominant per Bank)	
Wide >10m		Mature Forest, Wetland	<input type="checkbox"/>
Moderate 5-10m		Immature Forest, Shrub or Old Field	<input type="checkbox"/>
Narrow <5m		Residential, Park, New Field	<input type="checkbox"/>
None		Fenced Pasture	<input type="checkbox"/>
		Conservation Tillage	<input type="checkbox"/>
		Urban or Industrial	<input type="checkbox"/>
		Open Pasture, Row Crop	<input type="checkbox"/>
		Mining or Construction	<input type="checkbox"/>

COMMENTS \_\_\_\_\_

**FLOW REGIME (At Time of Evaluation) (Check ONLY one box):**

<input type="checkbox"/> Stream Flowing	<input type="checkbox"/> Moist Channel, isolated pools, no flow (Intermittent)
<input type="checkbox"/> Subsurface flow with isolated pools (Interstitial)	<input type="checkbox"/> Dry channel, no water (Ephemeral)

COMMENTS \_\_\_\_\_

**SINUOSITY (Number of bends per 61 m (200 ft) of channel) (Check ONLY one box):**

<input type="checkbox"/> None	<input type="checkbox"/> 1.0	<input type="checkbox"/> 2.0	<input type="checkbox"/> 3.0
<input type="checkbox"/> 0.5	<input type="checkbox"/> 1.5	<input type="checkbox"/> 2.5	<input type="checkbox"/> >3

**STREAM GRADIENT ESTIMATE**

<input type="checkbox"/> Flat (0.5 ft/100 ft)	<input type="checkbox"/> Flat to Moderate	<input type="checkbox"/> Moderate (2 ft/100 ft)	<input type="checkbox"/> Moderate to Severe	<input type="checkbox"/> Severe (10 ft/100 ft)
---	---	---	---	--



**ADDITIONAL STREAM INFORMATION (This Information Must Also be Completed):**

**QHEI PERFORMED?** -  Yes  No QHEI Score \_\_\_\_\_ (If Yes, Attach Completed QHEI Form)

**DOWNSTREAM DESIGNATED USE(S)**

- WWH Name: \_\_\_\_\_ Distance from Evaluated Stream \_\_\_\_\_
- CWH Name: \_\_\_\_\_ Distance from Evaluated Stream \_\_\_\_\_
- EWH Name: \_\_\_\_\_ Distance from Evaluated Stream \_\_\_\_\_

**MAPPING: ATTACH COPIES OF MAPS, INCLUDING THE ENTIRE WATERSHED AREA. CLEARLY MARK THE SITE LOCATION**

USGS Quadrangle Name: \_\_\_\_\_ NRCS Soil Map Page: \_\_\_\_\_ NRCS Soil Map Stream Order \_\_\_\_\_

County: \_\_\_\_\_ Township / City: \_\_\_\_\_

**MISCELLANEOUS**

Base Flow Conditions? (Y/N): \_\_\_\_\_ Date of last precipitation: \_\_\_\_\_ Quantity: \_\_\_\_\_

Photograph Information: \_\_\_\_\_

Elevated Turbidity? (Y/N): \_\_\_\_\_ Canopy (% open): \_\_\_\_\_

Were samples collected for water chemistry? (Y/N): \_\_\_\_\_ (Note lab sample no. or id. and attach results) Lab Number: \_\_\_\_\_

Field Measures: Temp (°C) \_\_\_\_\_ Dissolved Oxygen (mg/l) \_\_\_\_\_ pH (S.U.) \_\_\_\_\_ Conductivity (µmhos/cm) \_\_\_\_\_

Is the sampling reach representative of the stream (Y/N) \_\_\_\_\_ If not, please explain: \_\_\_\_\_

Additional comments/description of pollution impacts: \_\_\_\_\_

**BIOTIC EVALUATION**

Performed? (Y/N): \_\_\_\_\_ (If Yes, Record all observations. Voucher collections optional. NOTE: all voucher samples must be labeled with the site ID number. Include appropriate field data sheets from the Primary Headwater Habitat Assessment Manual)

Fish Observed? (Y/N) \_\_\_\_\_ Voucher? (Y/N) \_\_\_\_\_ Salamanders Observed? (Y/N) \_\_\_\_\_ Voucher? (Y/N) \_\_\_\_\_  
Frogs or Tadpoles Observed? (Y/N) \_\_\_\_\_ Voucher? (Y/N) \_\_\_\_\_ Aquatic Macroinvertebrates Observed? (Y/N) \_\_\_\_\_ Voucher? (Y/N) \_\_\_\_\_

Comments Regarding Biology: \_\_\_\_\_

**DRAWING AND NARRATIVE DESCRIPTION OF STREAM REACH (This must be completed):**

Include important landmarks and other features of interest for site evaluation and a narrative description of the stream's location

FLOW 



# Primary Headwater Habitat Evaluation Form

HHEI Score (sum of metrics 1, 2, 3) :

SITE NAME/LOCATION \_\_\_\_\_

\_\_\_\_\_ SITE NUMBER \_\_\_\_\_ RIVER BASIN \_\_\_\_\_ DRAINAGE AREA (mi<sup>2</sup>) \_\_\_\_\_

LENGTH OF STREAM REACH (ft) \_\_\_\_\_ LAT. \_\_\_\_\_ LONG. \_\_\_\_\_ RIVER CODE \_\_\_\_\_ RIVER MILE \_\_\_\_\_

DATE \_\_\_\_\_ SCORER \_\_\_\_\_ COMMENTS \_\_\_\_\_

**NOTE: Complete All Items On This Form - Refer to "Field Evaluation Manual for Ohio's PWH Streams" for Instructions**

**STREAM CHANNEL MODIFICATIONS:**

NONE / NATURAL CHANNEL  RECOVERED  RECOVERING  RECENT OR NO RECOVERY

**1. SUBSTRATE (Estimate percent of every type of substrate present. Check ONLY two predominant substrate TYPE boxes (Max of 32). Add total number of significant substrate types found (Max of 8). Final metric score is sum of boxes A & B.**

TYPE	PERCENT	TYPE	PERCENT
<input type="checkbox"/> <input type="checkbox"/> BLDR SLABS [16 pts]	_____	<input type="checkbox"/> <input type="checkbox"/> SILT [3 pt]	_____
<input type="checkbox"/> <input type="checkbox"/> BOULDER (>256 mm) [16 pts]	_____	<input type="checkbox"/> <input type="checkbox"/> LEAF PACK/WOODY DEBRIS [3 pts]	_____
<input type="checkbox"/> <input type="checkbox"/> BEDROCK [16 pt]	_____	<input type="checkbox"/> <input type="checkbox"/> FINE DETRITUS [3 pts]	_____
<input type="checkbox"/> <input type="checkbox"/> COBBLE (65-256 mm) [12 pts]	_____	<input type="checkbox"/> <input type="checkbox"/> CLAY or HARDPAN [0 pt]	_____
<input type="checkbox"/> <input type="checkbox"/> GRAVEL (2-64 mm) [9 pts]	_____	<input type="checkbox"/> <input type="checkbox"/> MUCK [0 pts]	_____
<input type="checkbox"/> <input type="checkbox"/> SAND (<2 mm) [6 pts]	_____	<input type="checkbox"/> <input type="checkbox"/> ARTIFICIAL [3 pts]	_____

Total of Percentages of Bldr Slabs, Boulder, Cobble, Bedrock \_\_\_\_\_

(A)

Substrate Percentage Check

(B)

SCORE OF TWO MOST PREDOMINATE SUBSTRATE TYPES:

TOTAL NUMBER OF SUBSTRATE TYPES:

## HHEI Metric Points

Substrate Max = 40

A + B

**2. Maximum Pool Depth (Measure the maximum pool depth within the 61 meter (200 ft) evaluation reach at the time of evaluation. Avoid plunge pools from road culverts or storm water pipes) (Check ONLY one box):**

<input type="checkbox"/> > 30 centimeters [20 pts]	<input type="checkbox"/> > 5 cm - 10 cm [15 pts]
<input type="checkbox"/> > 22.5 - 30 cm [30 pts]	<input type="checkbox"/> < 5 cm [5 pts]
<input type="checkbox"/> > 10 - 22.5 cm [25 pts]	<input type="checkbox"/> NO WATER OR MOIST CHANNEL [0 pts]

COMMENTS \_\_\_\_\_ MAXIMUM POOL DEPTH (centimeters):

Pool Depth Max = 30

**3. BANK FULL WIDTH (Measured as the average of 3-4 measurements) (Check ONLY one box):**

<input type="checkbox"/> > 4.0 meters (> 13') [30 pts]	<input type="checkbox"/> > 1.0 m - 1.5 m (> 3' 3" - 4' 8") [15 pts]
<input type="checkbox"/> > 3.0 m - 4.0 m (> 9' 7" - 13') [25 pts]	<input type="checkbox"/> ≤ 1.0 m (≤ 3' 3") [5 pts]
<input type="checkbox"/> > 1.5 m - 3.0 m (> 9' 7" - 4' 8") [20 pts]	

COMMENTS \_\_\_\_\_ AVERAGE BANKFULL WIDTH (meters):

Bankfull Width Max=30

**This information must also be completed**

**RIPARIAN ZONE AND FLOODPLAIN QUALITY** ☆NOTE: River Left (L) and Right (R) as looking downstream ☆

RIPARIAN WIDTH

FLOODPLAIN QUALITY

L	R	(Per Bank)	L	R	(Most Predominant per Bank)	L	R	
<input type="checkbox"/>	<input type="checkbox"/>	Wide >10m	<input type="checkbox"/>	<input type="checkbox"/>	Mature Forest, Wetland	<input type="checkbox"/>	<input type="checkbox"/>	Conservation Tillage
<input type="checkbox"/>	<input type="checkbox"/>	Moderate 5-10m	<input type="checkbox"/>	<input type="checkbox"/>	Immature Forest, Shrub or Old Field	<input type="checkbox"/>	<input type="checkbox"/>	Urban or Industrial
<input type="checkbox"/>	<input type="checkbox"/>	Narrow <5m	<input type="checkbox"/>	<input type="checkbox"/>	Residential, Park, New Field	<input type="checkbox"/>	<input type="checkbox"/>	Open Pasture, Row Crop
<input type="checkbox"/>	<input type="checkbox"/>	None	<input type="checkbox"/>	<input type="checkbox"/>	Fenced Pasture	<input type="checkbox"/>	<input type="checkbox"/>	Mining or Construction

COMMENTS \_\_\_\_\_

**FLOW REGIME (At Time of Evaluation) (Check ONLY one box):**

<input type="checkbox"/> Stream Flowing	<input type="checkbox"/> Moist Channel, isolated pools, no flow (Intermittent)
<input type="checkbox"/> Subsurface flow with isolated pools (Interstitial)	<input type="checkbox"/> Dry channel, no water (Ephemeral)

COMMENTS \_\_\_\_\_

**SINUOSITY (Number of bends per 61 m (200 ft) of channel) (Check ONLY one box):**

<input type="checkbox"/> None	<input type="checkbox"/> 1.0	<input type="checkbox"/> 2.0	<input type="checkbox"/> 3.0
<input type="checkbox"/> 0.5	<input type="checkbox"/> 1.5	<input type="checkbox"/> 2.5	<input type="checkbox"/> >3

**STREAM GRADIENT ESTIMATE**

Flat (0.5 ft/100 ft)  Flat to Moderate  Moderate (2 ft/100 ft)  Moderate to Severe  Severe (10 ft/100 ft)

**ADDITIONAL STREAM INFORMATION (This Information Must Also be Completed):**

**QHEI PERFORMED?** -  Yes  No QHEI Score \_\_\_\_\_ (If Yes, Attach Completed QHEI Form)

**DOWNSTREAM DESIGNATED USE(S)**

- WWH Name: \_\_\_\_\_ Distance from Evaluated Stream \_\_\_\_\_
- CWH Name: \_\_\_\_\_ Distance from Evaluated Stream \_\_\_\_\_
- EWH Name: \_\_\_\_\_ Distance from Evaluated Stream \_\_\_\_\_

**MAPPING: ATTACH COPIES OF MAPS, INCLUDING THE ENTIRE WATERSHED AREA. CLEARLY MARK THE SITE LOCATION**

USGS Quadrangle Name: \_\_\_\_\_ NRCS Soil Map Page: \_\_\_\_\_ NRCS Soil Map Stream Order \_\_\_\_\_

County: \_\_\_\_\_ Township / City: \_\_\_\_\_

**MISCELLANEOUS**

Base Flow Conditions? (Y/N): \_\_\_\_\_ Date of last precipitation: \_\_\_\_\_ Quantity: \_\_\_\_\_

Photograph Information: \_\_\_\_\_

Elevated Turbidity? (Y/N): \_\_\_\_\_ Canopy (% open): \_\_\_\_\_

Were samples collected for water chemistry? (Y/N): \_\_\_\_\_ (Note lab sample no. or id. and attach results) Lab Number: \_\_\_\_\_

Field Measures: Temp (°C) \_\_\_\_\_ Dissolved Oxygen (mg/l) \_\_\_\_\_ pH (S.U.) \_\_\_\_\_ Conductivity (µmhos/cm) \_\_\_\_\_

Is the sampling reach representative of the stream (Y/N) \_\_\_\_\_ If not, please explain: \_\_\_\_\_

Additional comments/description of pollution impacts: \_\_\_\_\_

**BIOTIC EVALUATION**

Performed? (Y/N): \_\_\_\_\_ (If Yes, Record all observations. Voucher collections optional. NOTE: all voucher samples must be labeled with the site ID number. Include appropriate field data sheets from the Primary Headwater Habitat Assessment Manual)

Fish Observed? (Y/N) \_\_\_\_\_ Voucher? (Y/N) \_\_\_\_\_ Salamanders Observed? (Y/N) \_\_\_\_\_ Voucher? (Y/N) \_\_\_\_\_  
Frogs or Tadpoles Observed? (Y/N) \_\_\_\_\_ Voucher? (Y/N) \_\_\_\_\_ Aquatic Macroinvertebrates Observed? (Y/N) \_\_\_\_\_ Voucher? (Y/N) \_\_\_\_\_

Comments Regarding Biology: \_\_\_\_\_

**DRAWING AND NARRATIVE DESCRIPTION OF STREAM REACH (This must be completed):**

Include important landmarks and other features of interest for site evaluation and a narrative description of the stream's location

FLOW 



# Primary Headwater Habitat Evaluation Form

HHEI Score (sum of metrics 1, 2, 3) :

SITE NAME/LOCATION \_\_\_\_\_

\_\_\_\_\_ SITE NUMBER \_\_\_\_\_ RIVER BASIN \_\_\_\_\_ DRAINAGE AREA (mi<sup>2</sup>) \_\_\_\_\_

LENGTH OF STREAM REACH (ft) \_\_\_\_\_ LAT. \_\_\_\_\_ LONG. \_\_\_\_\_ RIVER CODE \_\_\_\_\_ RIVER MILE \_\_\_\_\_

DATE \_\_\_\_\_ SCORER \_\_\_\_\_ COMMENTS \_\_\_\_\_

**NOTE: Complete All Items On This Form - Refer to "Field Evaluation Manual for Ohio's PWH Streams" for Instructions**

**STREAM CHANNEL MODIFICATIONS:**

NONE / NATURAL CHANNEL  RECOVERED  RECOVERING  RECENT OR NO RECOVERY

**1. SUBSTRATE (Estimate percent of every type of substrate present. Check ONLY two predominant substrate TYPE boxes (Max of 32). Add total number of significant substrate types found (Max of 8). Final metric score is sum of boxes A & B.**

TYPE	PERCENT	TYPE	PERCENT
<input type="checkbox"/> <input type="checkbox"/> BLDR SLABS [16 pts]	_____	<input type="checkbox"/> <input type="checkbox"/> SILT [3 pt]	_____
<input type="checkbox"/> <input type="checkbox"/> BOULDER (>256 mm) [16 pts]	_____	<input type="checkbox"/> <input type="checkbox"/> LEAF PACK/WOODY DEBRIS [3 pts]	_____
<input type="checkbox"/> <input type="checkbox"/> BEDROCK [16 pt]	_____	<input type="checkbox"/> <input type="checkbox"/> FINE DETRITUS [3 pts]	_____
<input type="checkbox"/> <input type="checkbox"/> COBBLE (65-256 mm) [12 pts]	_____	<input type="checkbox"/> <input type="checkbox"/> CLAY or HARDPAN [0 pt]	_____
<input type="checkbox"/> <input type="checkbox"/> GRAVEL (2-64 mm) [9 pts]	_____	<input type="checkbox"/> <input type="checkbox"/> MUCK [0 pts]	_____
<input type="checkbox"/> <input type="checkbox"/> SAND (<2 mm) [6 pts]	_____	<input type="checkbox"/> <input type="checkbox"/> ARTIFICIAL [3 pts]	_____

Total of Percentages of Bldr Slabs, Boulder, Cobble, Bedrock \_\_\_\_\_

(A)

Substrate Percentage Check

(B)

SCORE OF TWO MOST PREDOMINATE SUBSTRATE TYPES:

TOTAL NUMBER OF SUBSTRATE TYPES:

## HHEI Metric Points

Substrate Max = 40

A + B

**2. Maximum Pool Depth (Measure the maximum pool depth within the 61 meter (200 ft) evaluation reach at the time of evaluation. Avoid plunge pools from road culverts or storm water pipes) (Check ONLY one box):**

<input type="checkbox"/> > 30 centimeters [20 pts]	<input type="checkbox"/> > 5 cm - 10 cm [15 pts]
<input type="checkbox"/> > 22.5 - 30 cm [30 pts]	<input type="checkbox"/> < 5 cm [5 pts]
<input type="checkbox"/> > 10 - 22.5 cm [25 pts]	<input type="checkbox"/> NO WATER OR MOIST CHANNEL [0 pts]

COMMENTS \_\_\_\_\_ MAXIMUM POOL DEPTH (centimeters):

Pool Depth Max = 30

**3. BANK FULL WIDTH (Measured as the average of 3-4 measurements) (Check ONLY one box):**

<input type="checkbox"/> > 4.0 meters (> 13') [30 pts]	<input type="checkbox"/> > 1.0 m - 1.5 m (> 3' 3" - 4' 8") [15 pts]
<input type="checkbox"/> > 3.0 m - 4.0 m (> 9' 7" - 13') [25 pts]	<input type="checkbox"/> ≤ 1.0 m (≤ 3' 3") [5 pts]
<input type="checkbox"/> > 1.5 m - 3.0 m (> 9' 7" - 4' 8") [20 pts]	

COMMENTS \_\_\_\_\_ AVERAGE BANKFULL WIDTH (meters):

Bankfull Width Max=30

**This information must also be completed**

**RIPARIAN ZONE AND FLOODPLAIN QUALITY** ☆NOTE: River Left (L) and Right (R) as looking downstream ☆

RIPARIAN WIDTH

L	R	(Per Bank)
<input type="checkbox"/>	<input type="checkbox"/>	Wide >10m
<input type="checkbox"/>	<input type="checkbox"/>	Moderate 5-10m
<input type="checkbox"/>	<input type="checkbox"/>	Narrow <5m
<input type="checkbox"/>	<input type="checkbox"/>	None

COMMENTS \_\_\_\_\_

FLOODPLAIN QUALITY

L	R	(Most Predominant per Bank)
<input type="checkbox"/>	<input type="checkbox"/>	Mature Forest, Wetland
<input type="checkbox"/>	<input type="checkbox"/>	Immature Forest, Shrub or Old Field
<input type="checkbox"/>	<input type="checkbox"/>	Residential, Park, New Field
<input type="checkbox"/>	<input type="checkbox"/>	Fenced Pasture

L	R	
<input type="checkbox"/>	<input type="checkbox"/>	Conservation Tillage
<input type="checkbox"/>	<input type="checkbox"/>	Urban or Industrial
<input type="checkbox"/>	<input type="checkbox"/>	Open Pasture, Row Crop
<input type="checkbox"/>	<input type="checkbox"/>	Mining or Construction

**FLOW REGIME (At Time of Evaluation) (Check ONLY one box):**

<input type="checkbox"/> Stream Flowing	<input type="checkbox"/> Moist Channel, isolated pools, no flow (Intermittent)
<input type="checkbox"/> Subsurface flow with isolated pools (Interstitial)	<input type="checkbox"/> Dry channel, no water (Ephemeral)

COMMENTS \_\_\_\_\_

**SINUOSITY (Number of bends per 61 m (200 ft) of channel) (Check ONLY one box):**

<input type="checkbox"/> None	<input type="checkbox"/> 1.0	<input type="checkbox"/> 2.0	<input type="checkbox"/> 3.0
<input type="checkbox"/> 0.5	<input type="checkbox"/> 1.5	<input type="checkbox"/> 2.5	<input type="checkbox"/> >3

**STREAM GRADIENT ESTIMATE**

Flat (0.5 ft/100 ft)  Flat to Moderate  Moderate (2 ft/100 ft)  Moderate to Severe  Severe (10 ft/100 ft)

**ADDITIONAL STREAM INFORMATION (This Information Must Also be Completed):**

**QHEI PERFORMED?** -  Yes  No QHEI Score \_\_\_\_\_ (If Yes, Attach Completed QHEI Form)

**DOWNSTREAM DESIGNATED USE(S)**

- WWH Name: \_\_\_\_\_ Distance from Evaluated Stream \_\_\_\_\_
- CWH Name: \_\_\_\_\_ Distance from Evaluated Stream \_\_\_\_\_
- EWH Name: \_\_\_\_\_ Distance from Evaluated Stream \_\_\_\_\_

**MAPPING: ATTACH COPIES OF MAPS, INCLUDING THE ENTIRE WATERSHED AREA. CLEARLY MARK THE SITE LOCATION**

USGS Quadrangle Name: \_\_\_\_\_ NRCS Soil Map Page: \_\_\_\_\_ NRCS Soil Map Stream Order \_\_\_\_\_

County: \_\_\_\_\_ Township / City: \_\_\_\_\_

**MISCELLANEOUS**

Base Flow Conditions? (Y/N): \_\_\_\_\_ Date of last precipitation: \_\_\_\_\_ Quantity: \_\_\_\_\_

Photograph Information: \_\_\_\_\_

Elevated Turbidity? (Y/N): \_\_\_\_\_ Canopy (% open): \_\_\_\_\_

Were samples collected for water chemistry? (Y/N): \_\_\_\_\_ (Note lab sample no. or id. and attach results) Lab Number: \_\_\_\_\_

Field Measures: Temp (°C) \_\_\_\_\_ Dissolved Oxygen (mg/l) \_\_\_\_\_ pH (S.U.) \_\_\_\_\_ Conductivity (µmhos/cm) \_\_\_\_\_

Is the sampling reach representative of the stream (Y/N) \_\_\_\_\_ If not, please explain: \_\_\_\_\_

Additional comments/description of pollution impacts: \_\_\_\_\_

**BIOTIC EVALUATION**

Performed? (Y/N): \_\_\_\_\_ (If Yes, Record all observations. Voucher collections optional. NOTE: all voucher samples must be labeled with the site ID number. Include appropriate field data sheets from the Primary Headwater Habitat Assessment Manual)

Fish Observed? (Y/N) \_\_\_\_\_ Voucher? (Y/N) \_\_\_\_\_ Salamanders Observed? (Y/N) \_\_\_\_\_ Voucher? (Y/N) \_\_\_\_\_  
Frogs or Tadpoles Observed? (Y/N) \_\_\_\_\_ Voucher? (Y/N) \_\_\_\_\_ Aquatic Macroinvertebrates Observed? (Y/N) \_\_\_\_\_ Voucher? (Y/N) \_\_\_\_\_

Comments Regarding Biology: \_\_\_\_\_

**DRAWING AND NARRATIVE DESCRIPTION OF STREAM REACH (This must be completed):**

Include important landmarks and other features of interest for site evaluation and a narrative description of the stream's location

FLOW 



# Primary Headwater Habitat Evaluation Form

HHEI Score (sum of metrics 1, 2, 3) :

SITE NAME/LOCATION \_\_\_\_\_  
 \_\_\_\_\_ SITE NUMBER \_\_\_\_\_ RIVER BASIN \_\_\_\_\_ DRAINAGE AREA (mi<sup>2</sup>) \_\_\_\_\_  
 LENGTH OF STREAM REACH (ft) \_\_\_\_\_ LAT. \_\_\_\_\_ LONG. \_\_\_\_\_ RIVER CODE \_\_\_\_\_ RIVER MILE \_\_\_\_\_  
 DATE \_\_\_\_\_ SCORER \_\_\_\_\_ COMMENTS \_\_\_\_\_

**NOTE: Complete All Items On This Form - Refer to "Field Evaluation Manual for Ohio's PWH Streams" for Instructions**

**STREAM CHANNEL MODIFICATIONS:**

NONE / NATURAL CHANNEL  RECOVERED  RECOVERING  RECENT OR NO RECOVERY

**1. SUBSTRATE (Estimate percent of every type of substrate present. Check ONLY two predominant substrate TYPE boxes (Max of 32). Add total number of significant substrate types found (Max of 8). Final metric score is sum of boxes A & B.**

TYPE	PERCENT	TYPE	PERCENT
<input type="checkbox"/> <input type="checkbox"/> BLDR SLABS [16 pts]	_____	<input type="checkbox"/> <input type="checkbox"/> SILT [3 pt]	_____
<input type="checkbox"/> <input type="checkbox"/> BOULDER (>256 mm) [16 pts]	_____	<input type="checkbox"/> <input type="checkbox"/> LEAF PACK/WOODY DEBRIS [3 pts]	_____
<input type="checkbox"/> <input type="checkbox"/> BEDROCK [16 pt]	_____	<input type="checkbox"/> <input type="checkbox"/> FINE DETRITUS [3 pts]	_____
<input type="checkbox"/> <input type="checkbox"/> COBBLE (65-256 mm) [12 pts]	_____	<input type="checkbox"/> <input type="checkbox"/> CLAY or HARDPAN [0 pt]	_____
<input type="checkbox"/> <input type="checkbox"/> GRAVEL (2-64 mm) [9 pts]	_____	<input type="checkbox"/> <input type="checkbox"/> MUCK [0 pts]	_____
<input type="checkbox"/> <input type="checkbox"/> SAND (<2 mm) [6 pts]	_____	<input type="checkbox"/> <input type="checkbox"/> ARTIFICIAL [3 pts]	_____

Total of Percentages of Bldr Slabs, Boulder, Cobble, Bedrock \_\_\_\_\_

(A)

Substrate Percentage Check

(B)

SCORE OF TWO MOST PREDOMINATE SUBSTRATE TYPES:

TOTAL NUMBER OF SUBSTRATE TYPES:

### HHEI Metric Points

Substrate Max = 40

A + B

**2. Maximum Pool Depth (Measure the maximum pool depth within the 61 meter (200 ft) evaluation reach at the time of evaluation. Avoid plunge pools from road culverts or storm water pipes) (Check ONLY one box):**

<input type="checkbox"/> > 30 centimeters [20 pts]	<input type="checkbox"/> > 5 cm - 10 cm [15 pts]
<input type="checkbox"/> > 22.5 - 30 cm [30 pts]	<input type="checkbox"/> < 5 cm [5 pts]
<input type="checkbox"/> > 10 - 22.5 cm [25 pts]	<input type="checkbox"/> NO WATER OR MOIST CHANNEL [0 pts]

COMMENTS \_\_\_\_\_ MAXIMUM POOL DEPTH (centimeters):

Pool Depth Max = 30

**3. BANK FULL WIDTH (Measured as the average of 3-4 measurements) (Check ONLY one box):**

<input type="checkbox"/> > 4.0 meters (> 13') [30 pts]	<input type="checkbox"/> > 1.0 m - 1.5 m (> 3' 3" - 4' 8") [15 pts]
<input type="checkbox"/> > 3.0 m - 4.0 m (> 9' 7" - 13') [25 pts]	<input type="checkbox"/> ≤ 1.0 m (≤ 3' 3") [5 pts]
<input type="checkbox"/> > 1.5 m - 3.0 m (> 9' 7" - 4' 8") [20 pts]	

COMMENTS \_\_\_\_\_ AVERAGE BANKFULL WIDTH (meters):

Bankfull Width Max=30

**This information must also be completed**

**RIPARIAN ZONE AND FLOODPLAIN QUALITY** ☆NOTE: River Left (L) and Right (R) as looking downstream ☆

RIPARIAN WIDTH

L	R	(Per Bank)
<input type="checkbox"/>	<input type="checkbox"/>	Wide >10m
<input type="checkbox"/>	<input type="checkbox"/>	Moderate 5-10m
<input type="checkbox"/>	<input type="checkbox"/>	Narrow <5m
<input type="checkbox"/>	<input type="checkbox"/>	None

COMMENTS \_\_\_\_\_

FLOODPLAIN QUALITY

L	R	(Most Predominant per Bank)
<input type="checkbox"/>	<input type="checkbox"/>	Mature Forest, Wetland
<input type="checkbox"/>	<input type="checkbox"/>	Immature Forest, Shrub or Old Field
<input type="checkbox"/>	<input type="checkbox"/>	Residential, Park, New Field
<input type="checkbox"/>	<input type="checkbox"/>	Fenced Pasture

L	R	
<input type="checkbox"/>	<input type="checkbox"/>	Conservation Tillage
<input type="checkbox"/>	<input type="checkbox"/>	Urban or Industrial
<input type="checkbox"/>	<input type="checkbox"/>	Open Pasture, Row Crop
<input type="checkbox"/>	<input type="checkbox"/>	Mining or Construction

**FLOW REGIME (At Time of Evaluation) (Check ONLY one box):**

<input type="checkbox"/> Stream Flowing	<input type="checkbox"/> Moist Channel, isolated pools, no flow (Intermittent)
<input type="checkbox"/> Subsurface flow with isolated pools (Interstitial)	<input type="checkbox"/> Dry channel, no water (Ephemeral)

COMMENTS \_\_\_\_\_

**SINUOSITY (Number of bends per 61 m (200 ft) of channel) (Check ONLY one box):**

<input type="checkbox"/> None	<input type="checkbox"/> 1.0	<input type="checkbox"/> 2.0	<input type="checkbox"/> 3.0
<input type="checkbox"/> 0.5	<input type="checkbox"/> 1.5	<input type="checkbox"/> 2.5	<input type="checkbox"/> >3

**STREAM GRADIENT ESTIMATE**

Flat (0.5 ft/100 ft)  Flat to Moderate  Moderate (2 ft/100 ft)  Moderate to Severe  Severe (10 ft/100 ft)

**ADDITIONAL STREAM INFORMATION (This Information Must Also be Completed):**

**QHEI PERFORMED?** -  Yes  No QHEI Score \_\_\_\_\_ (If Yes, Attach Completed QHEI Form)

**DOWNSTREAM DESIGNATED USE(S)**

- WWH Name: \_\_\_\_\_ Distance from Evaluated Stream \_\_\_\_\_
- CWH Name: \_\_\_\_\_ Distance from Evaluated Stream \_\_\_\_\_
- EWH Name: \_\_\_\_\_ Distance from Evaluated Stream \_\_\_\_\_

**MAPPING: ATTACH COPIES OF MAPS, INCLUDING THE ENTIRE WATERSHED AREA. CLEARLY MARK THE SITE LOCATION**

USGS Quadrangle Name: \_\_\_\_\_ NRCS Soil Map Page: \_\_\_\_\_ NRCS Soil Map Stream Order \_\_\_\_\_

County: \_\_\_\_\_ Township / City: \_\_\_\_\_

**MISCELLANEOUS**

Base Flow Conditions? (Y/N): \_\_\_\_\_ Date of last precipitation: \_\_\_\_\_ Quantity: \_\_\_\_\_

Photograph Information: \_\_\_\_\_

Elevated Turbidity? (Y/N): \_\_\_\_\_ Canopy (% open): \_\_\_\_\_

Were samples collected for water chemistry? (Y/N): \_\_\_\_\_ (Note lab sample no. or id. and attach results) Lab Number: \_\_\_\_\_

Field Measures: Temp (°C) \_\_\_\_\_ Dissolved Oxygen (mg/l) \_\_\_\_\_ pH (S.U.) \_\_\_\_\_ Conductivity (µmhos/cm) \_\_\_\_\_

Is the sampling reach representative of the stream (Y/N) \_\_\_\_\_ If not, please explain: \_\_\_\_\_

Additional comments/description of pollution impacts: \_\_\_\_\_

**BIOTIC EVALUATION**

Performed? (Y/N): \_\_\_\_\_ (If Yes, Record all observations. Voucher collections optional. NOTE: all voucher samples must be labeled with the site ID number. Include appropriate field data sheets from the Primary Headwater Habitat Assessment Manual)

Fish Observed? (Y/N) \_\_\_\_\_ Voucher? (Y/N) \_\_\_\_\_ Salamanders Observed? (Y/N) \_\_\_\_\_ Voucher? (Y/N) \_\_\_\_\_  
Frogs or Tadpoles Observed? (Y/N) \_\_\_\_\_ Voucher? (Y/N) \_\_\_\_\_ Aquatic Macroinvertebrates Observed? (Y/N) \_\_\_\_\_ Voucher? (Y/N) \_\_\_\_\_

Comments Regarding Biology: \_\_\_\_\_

**DRAWING AND NARRATIVE DESCRIPTION OF STREAM REACH (This must be completed):**

Include important landmarks and other features of interest for site evaluation and a narrative description of the stream's location

FLOW 



SITE NAME/LOCATION \_\_\_\_\_  
 \_\_\_\_\_ SITE NUMBER \_\_\_\_\_ RIVER BASIN \_\_\_\_\_ DRAINAGE AREA (mi<sup>2</sup>) \_\_\_\_\_  
 LENGTH OF STREAM REACH (ft) \_\_\_\_\_ LAT. \_\_\_\_\_ LONG. \_\_\_\_\_ RIVER CODE \_\_\_\_\_ RIVER MILE \_\_\_\_\_  
 DATE \_\_\_\_\_ SCORER \_\_\_\_\_ COMMENTS \_\_\_\_\_

**NOTE: Complete All Items On This Form - Refer to "Field Evaluation Manual for Ohio's PWH Streams" for Instructions**

**STREAM CHANNEL MODIFICATIONS:**  NONE / NATURAL CHANNEL  RECOVERED  RECOVERING  RECENT OR NO RECOVERY

**1. SUBSTRATE (Estimate percent of every type of substrate present. Check ONLY two predominant substrate TYPE boxes (Max of 32). Add total number of significant substrate types found (Max of 8). Final metric score is sum of boxes A & B.)**

TYPE	PERCENT	TYPE	PERCENT
<input type="checkbox"/> <input type="checkbox"/> BLDR SLABS [16 pts]	_____	<input type="checkbox"/> <input type="checkbox"/> SILT [3 pt]	_____
<input type="checkbox"/> <input type="checkbox"/> BOULDER (>256 mm) [16 pts]	_____	<input type="checkbox"/> <input type="checkbox"/> LEAF PACK/WOODY DEBRIS [3 pts]	_____
<input type="checkbox"/> <input type="checkbox"/> BEDROCK [16 pt]	_____	<input type="checkbox"/> <input type="checkbox"/> FINE DETRITUS [3 pts]	_____
<input type="checkbox"/> <input type="checkbox"/> COBBLE (65-256 mm) [12 pts]	_____	<input type="checkbox"/> <input type="checkbox"/> CLAY or HARDPAN [0 pt]	_____
<input type="checkbox"/> <input type="checkbox"/> GRAVEL (2-64 mm) [9 pts]	_____	<input type="checkbox"/> <input type="checkbox"/> MUCK [0 pts]	_____
<input type="checkbox"/> <input type="checkbox"/> SAND (<2 mm) [6 pts]	_____	<input type="checkbox"/> <input type="checkbox"/> ARTIFICIAL [3 pts]	_____

Total of Percentages of Bldr Slabs, Boulder, Cobble, Bedrock **(A)** \_\_\_\_\_

Substrate Percentage Check **(B)** \_\_\_\_\_

**SCORE OF TWO MOST PREDOMINATE SUBSTRATE TYPES:** \_\_\_\_\_ **TOTAL NUMBER OF SUBSTRATE TYPES:** \_\_\_\_\_

---

**2. Maximum Pool Depth (Measure the maximum pool depth within the 61 meter (200 ft) evaluation reach at the time of evaluation. Avoid plunge pools from road culverts or storm water pipes) (Check ONLY one box):**

<input type="checkbox"/> > 30 centimeters [20 pts]	<input type="checkbox"/> > 5 cm - 10 cm [15 pts]
<input type="checkbox"/> > 22.5 - 30 cm [30 pts]	<input type="checkbox"/> < 5 cm [5 pts]
<input type="checkbox"/> > 10 - 22.5 cm [25 pts]	<input type="checkbox"/> NO WATER OR MOIST CHANNEL [0 pts]

**COMMENTS** \_\_\_\_\_ **MAXIMUM POOL DEPTH (centimeters):** \_\_\_\_\_

---

**3. BANK FULL WIDTH (Measured as the average of 3-4 measurements) (Check ONLY one box):**

<input type="checkbox"/> > 4.0 meters (> 13') [30 pts]	<input type="checkbox"/> > 1.0 m - 1.5 m (> 3' 3" - 4' 8") [15 pts]
<input type="checkbox"/> > 3.0 m - 4.0 m (> 9' 7" - 13') [25 pts]	<input type="checkbox"/> ≤ 1.0 m (≤ 3' 3") [5 pts]
<input type="checkbox"/> > 1.5 m - 3.0 m (> 9' 7" - 4' 8") [20 pts]	

**COMMENTS** \_\_\_\_\_ **AVERAGE BANKFULL WIDTH (meters):** \_\_\_\_\_

**HHEI Metric Points**

Substrate Max = 40

A + B

Pool Depth Max = 30

Bankfull Width Max=30

**This information must also be completed**

**RIPARIAN ZONE AND FLOODPLAIN QUALITY** ☆NOTE: River Left (L) and Right (R) as looking downstream ☆

RIPARIAN WIDTH

- |                          |                          |                |
|--------------------------|--------------------------|----------------|
| L                        | R                        | (Per Bank)     |
| <input type="checkbox"/> | <input type="checkbox"/> | Wide >10m      |
| <input type="checkbox"/> | <input type="checkbox"/> | Moderate 5-10m |
| <input type="checkbox"/> | <input type="checkbox"/> | Narrow <5m     |
| <input type="checkbox"/> | <input type="checkbox"/> | None           |

COMMENTS \_\_\_\_\_

FLOODPLAIN QUALITY

- |                          |                          |                                     |
|--------------------------|--------------------------|-------------------------------------|
| L                        | R                        | (Most Predominant per Bank)         |
| <input type="checkbox"/> | <input type="checkbox"/> | Mature Forest, Wetland              |
| <input type="checkbox"/> | <input type="checkbox"/> | Immature Forest, Shrub or Old Field |
| <input type="checkbox"/> | <input type="checkbox"/> | Residential, Park, New Field        |
| <input type="checkbox"/> | <input type="checkbox"/> | Fenced Pasture                      |

- |                          |                          |                        |
|--------------------------|--------------------------|------------------------|
| L                        | R                        |                        |
| <input type="checkbox"/> | <input type="checkbox"/> | Conservation Tillage   |
| <input type="checkbox"/> | <input type="checkbox"/> | Urban or Industrial    |
| <input type="checkbox"/> | <input type="checkbox"/> | Open Pasture, Row Crop |
| <input type="checkbox"/> | <input type="checkbox"/> | Mining or Construction |

**FLOW REGIME (At Time of Evaluation) (Check ONLY one box):**

- |   |  |
|---|--|
| <input type="checkbox"/> Stream Flowing                                     | <input type="checkbox"/> Moist Channel, isolated pools, no flow (Intermittent) |
| <input type="checkbox"/> Subsurface flow with isolated pools (Interstitial) | <input type="checkbox"/> Dry channel, no water (Ephemeral)                     |

COMMENTS \_\_\_\_\_

**SINUOSITY (Number of bends per 61 m (200 ft) of channel) (Check ONLY one box):**

- |                               |                              |                              |                              |
|-------------------------------|------------------------------|------------------------------|------------------------------|
| <input type="checkbox"/> None | <input type="checkbox"/> 1.0 | <input type="checkbox"/> 2.0 | <input type="checkbox"/> 3.0 |
| <input type="checkbox"/> 0.5  | <input type="checkbox"/> 1.5 | <input type="checkbox"/> 2.5 | <input type="checkbox"/> >3  |

**STREAM GRADIENT ESTIMATE**

- Flat (0.5 ft/100 ft)  Flat to Moderate  Moderate (2 ft/100 ft)  Moderate to Severe  Severe (10 ft/100 ft)



**ADDITIONAL STREAM INFORMATION (This Information Must Also be Completed):**

**QHEI PERFORMED?** -  Yes  No QHEI Score \_\_\_\_\_ (If Yes, Attach Completed QHEI Form)

**DOWNSTREAM DESIGNATED USE(S)**

- WWH Name: \_\_\_\_\_ Distance from Evaluated Stream \_\_\_\_\_
- CWH Name: \_\_\_\_\_ Distance from Evaluated Stream \_\_\_\_\_
- EWH Name: \_\_\_\_\_ Distance from Evaluated Stream \_\_\_\_\_

**MAPPING: ATTACH COPIES OF MAPS, INCLUDING THE ENTIRE WATERSHED AREA. CLEARLY MARK THE SITE LOCATION**

USGS Quadrangle Name: \_\_\_\_\_ NRCS Soil Map Page: \_\_\_\_\_ NRCS Soil Map Stream Order \_\_\_\_\_

County: \_\_\_\_\_ Township / City: \_\_\_\_\_

**MISCELLANEOUS**

Base Flow Conditions? (Y/N): \_\_\_\_\_ Date of last precipitation: \_\_\_\_\_ Quantity: \_\_\_\_\_

Photograph Information: \_\_\_\_\_

Elevated Turbidity? (Y/N): \_\_\_\_\_ Canopy (% open): \_\_\_\_\_

Were samples collected for water chemistry? (Y/N): \_\_\_\_\_ (Note lab sample no. or id. and attach results) Lab Number: \_\_\_\_\_

Field Measures: Temp (°C) \_\_\_\_\_ Dissolved Oxygen (mg/l) \_\_\_\_\_ pH (S.U.) \_\_\_\_\_ Conductivity (µmhos/cm) \_\_\_\_\_

Is the sampling reach representative of the stream (Y/N) \_\_\_\_\_ If not, please explain: \_\_\_\_\_

Additional comments/description of pollution impacts: \_\_\_\_\_

**BIOTIC EVALUATION**

Performed? (Y/N): \_\_\_\_\_ (If Yes, Record all observations. Voucher collections optional. NOTE: all voucher samples must be labeled with the site ID number. Include appropriate field data sheets from the Primary Headwater Habitat Assessment Manual)

Fish Observed? (Y/N) \_\_\_\_\_ Voucher? (Y/N) \_\_\_\_\_ Salamanders Observed? (Y/N) \_\_\_\_\_ Voucher? (Y/N) \_\_\_\_\_  
Frogs or Tadpoles Observed? (Y/N) \_\_\_\_\_ Voucher? (Y/N) \_\_\_\_\_ Aquatic Macroinvertebrates Observed? (Y/N) \_\_\_\_\_ Voucher? (Y/N) \_\_\_\_\_

Comments Regarding Biology: \_\_\_\_\_

**DRAWING AND NARRATIVE DESCRIPTION OF STREAM REACH (This must be completed):**

Include important landmarks and other features of interest for site evaluation and a narrative description of the stream's location

FLOW 

SITE NAME/LOCATION \_\_\_\_\_

\_\_\_\_\_ SITE NUMBER \_\_\_\_\_ RIVER BASIN \_\_\_\_\_ DRAINAGE AREA (mi<sup>2</sup>) \_\_\_\_\_

LENGTH OF STREAM REACH (ft) \_\_\_\_\_ LAT. \_\_\_\_\_ LONG. \_\_\_\_\_ RIVER CODE \_\_\_\_\_ RIVER MILE \_\_\_\_\_

DATE \_\_\_\_\_ SCORER \_\_\_\_\_ COMMENTS \_\_\_\_\_

**NOTE: Complete All Items On This Form - Refer to "Field Evaluation Manual for Ohio's PWH Streams" for Instructions**

**STREAM CHANNEL MODIFICATIONS:**     NONE / NATURAL CHANNEL     RECOVERED     RECOVERING     RECENT OR NO RECOVERY

**1. SUBSTRATE (Estimate percent of every type of substrate present. Check ONLY two predominant substrate TYPE boxes (Max of 32). Add total number of significant substrate types found (Max of 8). Final metric score is sum of boxes A & B.)**

TYPE	PERCENT	TYPE	PERCENT
<input type="checkbox"/> <input type="checkbox"/> BLDR SLABS [16 pts]	_____	<input type="checkbox"/> <input type="checkbox"/> SILT [3 pt]	_____
<input type="checkbox"/> <input type="checkbox"/> BOULDER (>256 mm) [16 pts]	_____	<input type="checkbox"/> <input type="checkbox"/> LEAF PACK/WOODY DEBRIS [3 pts]	_____
<input type="checkbox"/> <input type="checkbox"/> BEDROCK [16 pt]	_____	<input type="checkbox"/> <input type="checkbox"/> FINE DETRITUS [3 pts]	_____
<input type="checkbox"/> <input type="checkbox"/> COBBLE (65-256 mm) [12 pts]	_____	<input type="checkbox"/> <input type="checkbox"/> CLAY or HARDPAN [0 pt]	_____
<input type="checkbox"/> <input type="checkbox"/> GRAVEL (2-64 mm) [9 pts]	_____	<input type="checkbox"/> <input type="checkbox"/> MUCK [0 pts]	_____
<input type="checkbox"/> <input type="checkbox"/> SAND (<2 mm) [6 pts]	_____	<input type="checkbox"/> <input type="checkbox"/> ARTIFICIAL [3 pts]	_____

Total of Percentages of Bldr Slabs, Boulder, Cobble, Bedrock \_\_\_\_\_ (A)      Substrate Percentage Check \_\_\_\_\_ (B)

**SCORE OF TWO MOST PREDOMINATE SUBSTRATE TYPES:**       **TOTAL NUMBER OF SUBSTRATE TYPES:**

---

**2. Maximum Pool Depth (Measure the maximum pool depth within the 61 meter (200 ft) evaluation reach at the time of evaluation. Avoid plunge pools from road culverts or storm water pipes) (Check ONLY one box):**

<input type="checkbox"/> > 30 centimeters [20 pts]	<input type="checkbox"/> > 5 cm - 10 cm [15 pts]
<input type="checkbox"/> > 22.5 - 30 cm [30 pts]	<input type="checkbox"/> < 5 cm [5 pts]
<input type="checkbox"/> > 10 - 22.5 cm [25 pts]	<input type="checkbox"/> NO WATER OR MOIST CHANNEL [0 pts]

COMMENTS \_\_\_\_\_      **MAXIMUM POOL DEPTH (centimeters):**

---

**3. BANK FULL WIDTH (Measured as the average of 3-4 measurements) (Check ONLY one box):**

<input type="checkbox"/> > 4.0 meters (> 13') [30 pts]	<input type="checkbox"/> > 1.0 m - 1.5 m (> 3' 3" - 4' 8") [15 pts]
<input type="checkbox"/> > 3.0 m - 4.0 m (> 9' 7" - 13') [25 pts]	<input type="checkbox"/> ≤ 1.0 m (≤ 3' 3") [5 pts]
<input type="checkbox"/> > 1.5 m - 3.0 m (> 9' 7" - 4' 8") [20 pts]	

COMMENTS \_\_\_\_\_      **AVERAGE BANKFULL WIDTH (meters):**

**HHEI Metric Points**

Substrate Max = 40

A + B

---

Pool Depth Max = 30

---

Bankfull Width Max=30

**This information must also be completed**

**RIPARIAN ZONE AND FLOODPLAIN QUALITY**    ☆NOTE: River Left (L) and Right (R) as looking downstream ☆

<u>RIPARIAN WIDTH</u>		<u>FLOODPLAIN QUALITY</u>	
L	R	L	R
<input type="checkbox"/>	<input type="checkbox"/> (Per Bank)	<input type="checkbox"/>	<input type="checkbox"/> (Most Predominant per Bank)
<input type="checkbox"/>	Wide >10m	<input type="checkbox"/>	Mature Forest, Wetland
<input type="checkbox"/>	Moderate 5-10m	<input type="checkbox"/>	Immature Forest, Shrub or Old Field
<input type="checkbox"/>	Narrow <5m	<input type="checkbox"/>	Residential, Park, New Field
<input type="checkbox"/>	None	<input type="checkbox"/>	Fenced Pasture
		<input type="checkbox"/>	L
		<input type="checkbox"/>	R
		<input type="checkbox"/>	Conservation Tillage
		<input type="checkbox"/>	Urban or Industrial
		<input type="checkbox"/>	Open Pasture, Row Crop
		<input type="checkbox"/>	Mining or Construction

COMMENTS \_\_\_\_\_

**FLOW REGIME (At Time of Evaluation) (Check ONLY one box):**

<input type="checkbox"/> Stream Flowing	<input type="checkbox"/> Moist Channel, isolated pools, no flow (Intermittent)
<input type="checkbox"/> Subsurface flow with isolated pools (Interstitial)	<input type="checkbox"/> Dry channel, no water (Ephemeral)

COMMENTS \_\_\_\_\_

**SINUOSITY (Number of bends per 61 m (200 ft) of channel) (Check ONLY one box):**

<input type="checkbox"/> None	<input type="checkbox"/> 1.0	<input type="checkbox"/> 2.0	<input type="checkbox"/> 3.0
<input type="checkbox"/> 0.5	<input type="checkbox"/> 1.5	<input type="checkbox"/> 2.5	<input type="checkbox"/> >3

**STREAM GRADIENT ESTIMATE**

Flat (0.5 ft/100 ft)     Flat to Moderate     Moderate (2 ft/100 ft)     Moderate to Severe     Severe (10 ft/100 ft)

**ADDITIONAL STREAM INFORMATION (This Information Must Also be Completed):**

**QHEI PERFORMED?** -  Yes  No QHEI Score \_\_\_\_\_ (If Yes, Attach Completed QHEI Form)

**DOWNSTREAM DESIGNATED USE(S)**

- WWH Name: \_\_\_\_\_ Distance from Evaluated Stream \_\_\_\_\_
- CWH Name: \_\_\_\_\_ Distance from Evaluated Stream \_\_\_\_\_
- EWH Name: \_\_\_\_\_ Distance from Evaluated Stream \_\_\_\_\_

**MAPPING: ATTACH COPIES OF MAPS, INCLUDING THE ENTIRE WATERSHED AREA. CLEARLY MARK THE SITE LOCATION**

USGS Quadrangle Name: \_\_\_\_\_ NRCS Soil Map Page: \_\_\_\_\_ NRCS Soil Map Stream Order \_\_\_\_\_

County: \_\_\_\_\_ Township / City: \_\_\_\_\_

**MISCELLANEOUS**

Base Flow Conditions? (Y/N): \_\_\_\_\_ Date of last precipitation: \_\_\_\_\_ Quantity: \_\_\_\_\_

Photograph Information: \_\_\_\_\_

Elevated Turbidity? (Y/N): \_\_\_\_\_ Canopy (% open): \_\_\_\_\_

Were samples collected for water chemistry? (Y/N): \_\_\_\_\_ (Note lab sample no. or id. and attach results) Lab Number: \_\_\_\_\_

Field Measures: Temp (°C) \_\_\_\_\_ Dissolved Oxygen (mg/l) \_\_\_\_\_ pH (S.U.) \_\_\_\_\_ Conductivity (µmhos/cm) \_\_\_\_\_

Is the sampling reach representative of the stream (Y/N) \_\_\_\_\_ If not, please explain: \_\_\_\_\_

Additional comments/description of pollution impacts: \_\_\_\_\_

**BIOTIC EVALUATION**

Performed? (Y/N): \_\_\_\_\_ (If Yes, Record all observations. Voucher collections optional. NOTE: all voucher samples must be labeled with the site ID number. Include appropriate field data sheets from the Primary Headwater Habitat Assessment Manual)

Fish Observed? (Y/N) \_\_\_\_\_ Voucher? (Y/N) \_\_\_\_\_ Salamanders Observed? (Y/N) \_\_\_\_\_ Voucher? (Y/N) \_\_\_\_\_  
Frogs or Tadpoles Observed? (Y/N) \_\_\_\_\_ Voucher? (Y/N) \_\_\_\_\_ Aquatic Macroinvertebrates Observed? (Y/N) \_\_\_\_\_ Voucher? (Y/N) \_\_\_\_\_

Comments Regarding Biology: \_\_\_\_\_

**DRAWING AND NARRATIVE DESCRIPTION OF STREAM REACH (This must be completed):**

Include important landmarks and other features of interest for site evaluation and a narrative description of the stream's location

FLOW 



# Primary Headwater Habitat Evaluation Form

HHEI Score (sum of metrics 1, 2, 3) :

SITE NAME/LOCATION \_\_\_\_\_  
 \_\_\_\_\_ SITE NUMBER \_\_\_\_\_ RIVER BASIN \_\_\_\_\_ DRAINAGE AREA (mi<sup>2</sup>) \_\_\_\_\_  
 LENGTH OF STREAM REACH (ft) \_\_\_\_\_ LAT. \_\_\_\_\_ LONG. \_\_\_\_\_ RIVER CODE \_\_\_\_\_ RIVER MILE \_\_\_\_\_  
 DATE \_\_\_\_\_ SCORER \_\_\_\_\_ COMMENTS \_\_\_\_\_

**NOTE: Complete All Items On This Form - Refer to "Field Evaluation Manual for Ohio's PWH Streams" for Instructions**

**STREAM CHANNEL MODIFICATIONS:**

NONE / NATURAL CHANNEL  RECOVERED  RECOVERING  RECENT OR NO RECOVERY

**1. SUBSTRATE (Estimate percent of every type of substrate present. Check ONLY two predominant substrate TYPE boxes (Max of 32). Add total number of significant substrate types found (Max of 8). Final metric score is sum of boxes A & B.**

TYPE	PERCENT	TYPE	PERCENT
<input type="checkbox"/> <input type="checkbox"/> BLDR SLABS [16 pts]	_____	<input type="checkbox"/> <input type="checkbox"/> SILT [3 pt]	_____
<input type="checkbox"/> <input type="checkbox"/> BOULDER (>256 mm) [16 pts]	_____	<input type="checkbox"/> <input type="checkbox"/> LEAF PACK/WOODY DEBRIS [3 pts]	_____
<input type="checkbox"/> <input type="checkbox"/> BEDROCK [16 pt]	_____	<input type="checkbox"/> <input type="checkbox"/> FINE DETRITUS [3 pts]	_____
<input type="checkbox"/> <input type="checkbox"/> COBBLE (65-256 mm) [12 pts]	_____	<input type="checkbox"/> <input type="checkbox"/> CLAY or HARDPAN [0 pt]	_____
<input type="checkbox"/> <input type="checkbox"/> GRAVEL (2-64 mm) [9 pts]	_____	<input type="checkbox"/> <input type="checkbox"/> MUCK [0 pts]	_____
<input type="checkbox"/> <input type="checkbox"/> SAND (<2 mm) [6 pts]	_____	<input type="checkbox"/> <input type="checkbox"/> ARTIFICIAL [3 pts]	_____

Total of Percentages of Bldr Slabs, Boulder, Cobble, Bedrock \_\_\_\_\_

(A)

Substrate Percentage Check

(B)

SCORE OF TWO MOST PREDOMINATE SUBSTRATE TYPES:

TOTAL NUMBER OF SUBSTRATE TYPES:

### HHEI Metric Points

Substrate Max = 40

A + B

**2. Maximum Pool Depth (Measure the maximum pool depth within the 61 meter (200 ft) evaluation reach at the time of evaluation. Avoid plunge pools from road culverts or storm water pipes) (Check ONLY one box):**

<input type="checkbox"/> > 30 centimeters [20 pts]	<input type="checkbox"/> > 5 cm - 10 cm [15 pts]
<input type="checkbox"/> > 22.5 - 30 cm [30 pts]	<input type="checkbox"/> < 5 cm [5 pts]
<input type="checkbox"/> > 10 - 22.5 cm [25 pts]	<input type="checkbox"/> NO WATER OR MOIST CHANNEL [0 pts]

COMMENTS \_\_\_\_\_ MAXIMUM POOL DEPTH (centimeters):

Pool Depth Max = 30

**3. BANK FULL WIDTH (Measured as the average of 3-4 measurements) (Check ONLY one box):**

<input type="checkbox"/> > 4.0 meters (> 13') [30 pts]	<input type="checkbox"/> > 1.0 m - 1.5 m (> 3' 3" - 4' 8") [15 pts]
<input type="checkbox"/> > 3.0 m - 4.0 m (> 9' 7" - 13') [25 pts]	<input type="checkbox"/> ≤ 1.0 m (≤ 3' 3") [5 pts]
<input type="checkbox"/> > 1.5 m - 3.0 m (> 9' 7" - 4' 8") [20 pts]	

COMMENTS \_\_\_\_\_ AVERAGE BANKFULL WIDTH (meters):

Bankfull Width Max=30

**This information must also be completed**

**RIPARIAN ZONE AND FLOODPLAIN QUALITY** ☆NOTE: River Left (L) and Right (R) as looking downstream ☆

RIPARIAN WIDTH

L	R	(Per Bank)
<input type="checkbox"/>	<input type="checkbox"/>	Wide >10m
<input type="checkbox"/>	<input type="checkbox"/>	Moderate 5-10m
<input type="checkbox"/>	<input type="checkbox"/>	Narrow <5m
<input type="checkbox"/>	<input type="checkbox"/>	None

COMMENTS \_\_\_\_\_

FLOODPLAIN QUALITY

L	R	(Most Predominant per Bank)
<input type="checkbox"/>	<input type="checkbox"/>	Mature Forest, Wetland
<input type="checkbox"/>	<input type="checkbox"/>	Immature Forest, Shrub or Old Field
<input type="checkbox"/>	<input type="checkbox"/>	Residential, Park, New Field
<input type="checkbox"/>	<input type="checkbox"/>	Fenced Pasture

L	R	
<input type="checkbox"/>	<input type="checkbox"/>	Conservation Tillage
<input type="checkbox"/>	<input type="checkbox"/>	Urban or Industrial
<input type="checkbox"/>	<input type="checkbox"/>	Open Pasture, Row Crop
<input type="checkbox"/>	<input type="checkbox"/>	Mining or Construction

**FLOW REGIME (At Time of Evaluation) (Check ONLY one box):**

<input type="checkbox"/> Stream Flowing	<input type="checkbox"/> Moist Channel, isolated pools, no flow (Intermittent)
<input type="checkbox"/> Subsurface flow with isolated pools (Interstitial)	<input type="checkbox"/> Dry channel, no water (Ephemeral)

COMMENTS \_\_\_\_\_

**SINUOSITY (Number of bends per 61 m (200 ft) of channel) (Check ONLY one box):**

<input type="checkbox"/> None	<input type="checkbox"/> 1.0	<input type="checkbox"/> 2.0	<input type="checkbox"/> 3.0
<input type="checkbox"/> 0.5	<input type="checkbox"/> 1.5	<input type="checkbox"/> 2.5	<input type="checkbox"/> >3

**STREAM GRADIENT ESTIMATE**

Flat (0.5 ft/100 ft)  Flat to Moderate  Moderate (2 ft/100 ft)  Moderate to Severe  Severe (10 ft/100 ft)

**ADDITIONAL STREAM INFORMATION (This Information Must Also be Completed):**

**QHEI PERFORMED?** -  Yes  No QHEI Score \_\_\_\_\_ (If Yes, Attach Completed QHEI Form)

**DOWNSTREAM DESIGNATED USE(S)**

- WWH Name: \_\_\_\_\_ Distance from Evaluated Stream \_\_\_\_\_
- CWH Name: \_\_\_\_\_ Distance from Evaluated Stream \_\_\_\_\_
- EWH Name: \_\_\_\_\_ Distance from Evaluated Stream \_\_\_\_\_

**MAPPING: ATTACH COPIES OF MAPS, INCLUDING THE ENTIRE WATERSHED AREA. CLEARLY MARK THE SITE LOCATION**

USGS Quadrangle Name: \_\_\_\_\_ NRCS Soil Map Page: \_\_\_\_\_ NRCS Soil Map Stream Order \_\_\_\_\_

County: \_\_\_\_\_ Township / City: \_\_\_\_\_

**MISCELLANEOUS**

Base Flow Conditions? (Y/N): \_\_\_\_\_ Date of last precipitation: \_\_\_\_\_ Quantity: \_\_\_\_\_

Photograph Information: \_\_\_\_\_

Elevated Turbidity? (Y/N): \_\_\_\_\_ Canopy (% open): \_\_\_\_\_

Were samples collected for water chemistry? (Y/N): \_\_\_\_\_ (Note lab sample no. or id. and attach results) Lab Number: \_\_\_\_\_

Field Measures: Temp (°C) \_\_\_\_\_ Dissolved Oxygen (mg/l) \_\_\_\_\_ pH (S.U.) \_\_\_\_\_ Conductivity (µmhos/cm) \_\_\_\_\_

Is the sampling reach representative of the stream (Y/N) \_\_\_\_\_ If not, please explain: \_\_\_\_\_

Additional comments/description of pollution impacts: \_\_\_\_\_

**BIOTIC EVALUATION**

Performed? (Y/N): \_\_\_\_\_ (If Yes, Record all observations. Voucher collections optional. NOTE: all voucher samples must be labeled with the site ID number. Include appropriate field data sheets from the Primary Headwater Habitat Assessment Manual)

Fish Observed? (Y/N) \_\_\_\_\_ Voucher? (Y/N) \_\_\_\_\_ Salamanders Observed? (Y/N) \_\_\_\_\_ Voucher? (Y/N) \_\_\_\_\_  
Frogs or Tadpoles Observed? (Y/N) \_\_\_\_\_ Voucher? (Y/N) \_\_\_\_\_ Aquatic Macroinvertebrates Observed? (Y/N) \_\_\_\_\_ Voucher? (Y/N) \_\_\_\_\_

Comments Regarding Biology: \_\_\_\_\_

**DRAWING AND NARRATIVE DESCRIPTION OF STREAM REACH (This must be completed):**

Include important landmarks and other features of interest for site evaluation and a narrative description of the stream's location

FLOW 

SITE NAME/LOCATION \_\_\_\_\_

\_\_\_\_\_ SITE NUMBER \_\_\_\_\_ RIVER BASIN \_\_\_\_\_ DRAINAGE AREA (mi<sup>2</sup>) \_\_\_\_\_

LENGTH OF STREAM REACH (ft) \_\_\_\_\_ LAT. \_\_\_\_\_ LONG. \_\_\_\_\_ RIVER CODE \_\_\_\_\_ RIVER MILE \_\_\_\_\_

DATE \_\_\_\_\_ SCORER \_\_\_\_\_ COMMENTS \_\_\_\_\_

**NOTE: Complete All Items On This Form - Refer to "Field Evaluation Manual for Ohio's PWH Streams" for Instructions**

**STREAM CHANNEL MODIFICATIONS:**     NONE / NATURAL CHANNEL     RECOVERED     RECOVERING     RECENT OR NO RECOVERY

**1. SUBSTRATE (Estimate percent of every type of substrate present. Check ONLY two predominant substrate TYPE boxes (Max of 32). Add total number of significant substrate types found (Max of 8). Final metric score is sum of boxes A & B.**

TYPE	PERCENT	TYPE	PERCENT
<input type="checkbox"/> <input type="checkbox"/> BLDR SLABS [16 pts]	_____	<input type="checkbox"/> <input type="checkbox"/> SILT [3 pt]	_____
<input type="checkbox"/> <input type="checkbox"/> BOULDER (>256 mm) [16 pts]	_____	<input type="checkbox"/> <input type="checkbox"/> LEAF PACK/WOODY DEBRIS [3 pts]	_____
<input type="checkbox"/> <input type="checkbox"/> BEDROCK [16 pt]	_____	<input type="checkbox"/> <input type="checkbox"/> FINE DETRITUS [3 pts]	_____
<input type="checkbox"/> <input type="checkbox"/> COBBLE (65-256 mm) [12 pts]	_____	<input type="checkbox"/> <input type="checkbox"/> CLAY or HARDPAN [0 pt]	_____
<input type="checkbox"/> <input type="checkbox"/> GRAVEL (2-64 mm) [9 pts]	_____	<input type="checkbox"/> <input type="checkbox"/> MUCK [0 pts]	_____
<input type="checkbox"/> <input type="checkbox"/> SAND (<2 mm) [6 pts]	_____	<input type="checkbox"/> <input type="checkbox"/> ARTIFICIAL [3 pts]	_____

Total of Percentages of Bldr Slabs, Boulder, Cobble, Bedrock \_\_\_\_\_ **(A)**

Substrate Percentage Check \_\_\_\_\_ **(B)**

**SCORE OF TWO MOST PREDOMINATE SUBSTRATE TYPES:**     **TOTAL NUMBER OF SUBSTRATE TYPES:**

---

**2. Maximum Pool Depth (Measure the maximum pool depth within the 61 meter (200 ft) evaluation reach at the time of evaluation. Avoid plunge pools from road culverts or storm water pipes) (Check ONLY one box):**

<input type="checkbox"/> > 30 centimeters [20 pts]	<input type="checkbox"/> > 5 cm - 10 cm [15 pts]
<input type="checkbox"/> > 22.5 - 30 cm [30 pts]	<input type="checkbox"/> < 5 cm [5 pts]
<input type="checkbox"/> > 10 - 22.5 cm [25 pts]	<input type="checkbox"/> NO WATER OR MOIST CHANNEL [0 pts]

**COMMENTS** \_\_\_\_\_ **MAXIMUM POOL DEPTH (centimeters):**

---

**3. BANK FULL WIDTH (Measured as the average of 3-4 measurements) (Check ONLY one box):**

<input type="checkbox"/> > 4.0 meters (> 13') [30 pts]	<input type="checkbox"/> > 1.0 m - 1.5 m (> 3' 3" - 4' 8") [15 pts]
<input type="checkbox"/> > 3.0 m - 4.0 m (> 9' 7" - 13') [25 pts]	<input type="checkbox"/> ≤ 1.0 m (≤ 3' 3") [5 pts]
<input type="checkbox"/> > 1.5 m - 3.0 m (> 9' 7" - 4' 8") [20 pts]	

**COMMENTS** \_\_\_\_\_ **AVERAGE BANKFULL WIDTH (meters):**

**HHEI Metric Points**

Substrate Max = 40

A + B

---

Pool Depth Max = 30

---

Bankfull Width Max=30

**This information must also be completed**

**RIPARIAN ZONE AND FLOODPLAIN QUALITY**    ☆NOTE: River Left (L) and Right (R) as looking downstream ☆

<u>RIPARIAN WIDTH</u>		<u>FLOODPLAIN QUALITY</u>	
L	R	L	R
<input type="checkbox"/>	<input type="checkbox"/>	<input type="checkbox"/>	<input type="checkbox"/>
(Per Bank)		(Most Predominant per Bank)	
Wide >10m		Mature Forest, Wetland	<input type="checkbox"/>
Moderate 5-10m		Immature Forest, Shrub or Old Field	<input type="checkbox"/>
Narrow <5m		Residential, Park, New Field	<input type="checkbox"/>
None		Fenced Pasture	<input type="checkbox"/>
		Conservation Tillage	<input type="checkbox"/>
		Urban or Industrial	<input type="checkbox"/>
		Open Pasture, Row Crop	<input type="checkbox"/>
		Mining or Construction	<input type="checkbox"/>

**COMMENTS** \_\_\_\_\_

**FLOW REGIME (At Time of Evaluation) (Check ONLY one box):**

<input type="checkbox"/> Stream Flowing	<input type="checkbox"/> Moist Channel, isolated pools, no flow (Intermittent)
<input type="checkbox"/> Subsurface flow with isolated pools (Interstitial)	<input type="checkbox"/> Dry channel, no water (Ephemeral)

**COMMENTS** \_\_\_\_\_

**SINUOSITY (Number of bends per 61 m (200 ft) of channel) (Check ONLY one box):**

<input type="checkbox"/> None	<input type="checkbox"/> 1.0	<input type="checkbox"/> 2.0	<input type="checkbox"/> 3.0
<input type="checkbox"/> 0.5	<input type="checkbox"/> 1.5	<input type="checkbox"/> 2.5	<input type="checkbox"/> >3

**STREAM GRADIENT ESTIMATE**

<input type="checkbox"/> Flat (0.5 ft/100 ft)	<input type="checkbox"/> Flat to Moderate	<input type="checkbox"/> Moderate (2 ft/100 ft)	<input type="checkbox"/> Moderate to Severe	<input type="checkbox"/> Severe (10 ft/100 ft)
---	---	---	---	--

**ADDITIONAL STREAM INFORMATION (This Information Must Also be Completed):**

**QHEI PERFORMED?** -  Yes  No QHEI Score \_\_\_\_\_ (If Yes, Attach Completed QHEI Form)

**DOWNSTREAM DESIGNATED USE(S)**

- WWH Name: \_\_\_\_\_ Distance from Evaluated Stream \_\_\_\_\_
- CWH Name: \_\_\_\_\_ Distance from Evaluated Stream \_\_\_\_\_
- EWH Name: \_\_\_\_\_ Distance from Evaluated Stream \_\_\_\_\_

**MAPPING: ATTACH COPIES OF MAPS, INCLUDING THE ENTIRE WATERSHED AREA. CLEARLY MARK THE SITE LOCATION**

USGS Quadrangle Name: \_\_\_\_\_ NRCS Soil Map Page: \_\_\_\_\_ NRCS Soil Map Stream Order \_\_\_\_\_

County: \_\_\_\_\_ Township / City: \_\_\_\_\_

**MISCELLANEOUS**

Base Flow Conditions? (Y/N): \_\_\_\_\_ Date of last precipitation: \_\_\_\_\_ Quantity: \_\_\_\_\_

Photograph Information: \_\_\_\_\_

Elevated Turbidity? (Y/N): \_\_\_\_\_ Canopy (% open): \_\_\_\_\_

Were samples collected for water chemistry? (Y/N): \_\_\_\_\_ (Note lab sample no. or id. and attach results) Lab Number: \_\_\_\_\_

Field Measures: Temp (°C) \_\_\_\_\_ Dissolved Oxygen (mg/l) \_\_\_\_\_ pH (S.U.) \_\_\_\_\_ Conductivity (µmhos/cm) \_\_\_\_\_

Is the sampling reach representative of the stream (Y/N) \_\_\_\_\_ If not, please explain: \_\_\_\_\_

\_\_\_\_\_

Additional comments/description of pollution impacts: \_\_\_\_\_

\_\_\_\_\_

**BIOTIC EVALUATION**

Performed? (Y/N): \_\_\_\_\_ (If Yes, Record all observations. Voucher collections optional. NOTE: all voucher samples must be labeled with the site ID number. Include appropriate field data sheets from the Primary Headwater Habitat Assessment Manual)

Fish Observed? (Y/N) \_\_\_\_\_ Voucher? (Y/N) \_\_\_\_\_ Salamanders Observed? (Y/N) \_\_\_\_\_ Voucher? (Y/N) \_\_\_\_\_

Frogs or Tadpoles Observed? (Y/N) \_\_\_\_\_ Voucher? (Y/N) \_\_\_\_\_ Aquatic Macroinvertebrates Observed? (Y/N) \_\_\_\_\_ Voucher? (Y/N) \_\_\_\_\_

Comments Regarding Biology: \_\_\_\_\_

\_\_\_\_\_

\_\_\_\_\_

**DRAWING AND NARRATIVE DESCRIPTION OF STREAM REACH (This must be completed):**

Include important landmarks and other features of interest for site evaluation and a narrative description of the stream's location

FLOW 



# Primary Headwater Habitat Evaluation Form

HHEI Score (sum of metrics 1, 2, 3) :

SITE NAME/LOCATION \_\_\_\_\_  
 \_\_\_\_\_ SITE NUMBER \_\_\_\_\_ RIVER BASIN \_\_\_\_\_ DRAINAGE AREA (mi<sup>2</sup>) \_\_\_\_\_  
 LENGTH OF STREAM REACH (ft) \_\_\_\_\_ LAT. \_\_\_\_\_ LONG. \_\_\_\_\_ RIVER CODE \_\_\_\_\_ RIVER MILE \_\_\_\_\_  
 DATE \_\_\_\_\_ SCORER \_\_\_\_\_ COMMENTS \_\_\_\_\_

**NOTE: Complete All Items On This Form - Refer to "Field Evaluation Manual for Ohio's PWH Streams" for Instructions**

**STREAM CHANNEL MODIFICATIONS:**

NONE / NATURAL CHANNEL  RECOVERED  RECOVERING  RECENT OR NO RECOVERY

**1. SUBSTRATE (Estimate percent of every type of substrate present. Check ONLY two predominant substrate TYPE boxes (Max of 32). Add total number of significant substrate types found (Max of 8). Final metric score is sum of boxes A & B.**

TYPE	PERCENT	TYPE	PERCENT
<input type="checkbox"/> <input type="checkbox"/> BLDR SLABS [16 pts]	_____	<input type="checkbox"/> <input type="checkbox"/> SILT [3 pt]	_____
<input type="checkbox"/> <input type="checkbox"/> BOULDER (>256 mm) [16 pts]	_____	<input type="checkbox"/> <input type="checkbox"/> LEAF PACK/WOODY DEBRIS [3 pts]	_____
<input type="checkbox"/> <input type="checkbox"/> BEDROCK [16 pt]	_____	<input type="checkbox"/> <input type="checkbox"/> FINE DETRITUS [3 pts]	_____
<input type="checkbox"/> <input type="checkbox"/> COBBLE (65-256 mm) [12 pts]	_____	<input type="checkbox"/> <input type="checkbox"/> CLAY or HARDPAN [0 pt]	_____
<input type="checkbox"/> <input type="checkbox"/> GRAVEL (2-64 mm) [9 pts]	_____	<input type="checkbox"/> <input type="checkbox"/> MUCK [0 pts]	_____
<input type="checkbox"/> <input type="checkbox"/> SAND (<2 mm) [6 pts]	_____	<input type="checkbox"/> <input type="checkbox"/> ARTIFICIAL [3 pts]	_____

Total of Percentages of Bldr Slabs, Boulder, Cobble, Bedrock \_\_\_\_\_

(A)

Substrate Percentage Check

(B)

SCORE OF TWO MOST PREDOMINATE SUBSTRATE TYPES: \_\_\_\_\_

TOTAL NUMBER OF SUBSTRATE TYPES: \_\_\_\_\_

**HHEI Metric Points**

Substrate Max = 40

A + B

**2. Maximum Pool Depth (Measure the maximum pool depth within the 61 meter (200 ft) evaluation reach at the time of evaluation. Avoid plunge pools from road culverts or storm water pipes) (Check ONLY one box):**

<input type="checkbox"/> > 30 centimeters [20 pts]	<input type="checkbox"/> > 5 cm - 10 cm [15 pts]
<input type="checkbox"/> > 22.5 - 30 cm [30 pts]	<input type="checkbox"/> < 5 cm [5 pts]
<input type="checkbox"/> > 10 - 22.5 cm [25 pts]	<input type="checkbox"/> NO WATER OR MOIST CHANNEL [0 pts]

COMMENTS \_\_\_\_\_ MAXIMUM POOL DEPTH (centimeters): \_\_\_\_\_

Pool Depth Max = 30

**3. BANK FULL WIDTH (Measured as the average of 3-4 measurements) (Check ONLY one box):**

<input type="checkbox"/> > 4.0 meters (> 13') [30 pts]	<input type="checkbox"/> > 1.0 m - 1.5 m (> 3' 3" - 4' 8") [15 pts]
<input type="checkbox"/> > 3.0 m - 4.0 m (> 9' 7" - 13') [25 pts]	<input type="checkbox"/> ≤ 1.0 m (≤ 3' 3") [5 pts]
<input type="checkbox"/> > 1.5 m - 3.0 m (> 9' 7" - 4' 8") [20 pts]	

COMMENTS \_\_\_\_\_ AVERAGE BANKFULL WIDTH (meters): \_\_\_\_\_

Bankfull Width Max=30

**This information must also be completed**

**RIPARIAN ZONE AND FLOODPLAIN QUALITY** ☆NOTE: River Left (L) and Right (R) as looking downstream ☆

RIPARIAN WIDTH

FLOODPLAIN QUALITY

L	R	(Per Bank)	L	R	(Most Predominant per Bank)	L	R	
<input type="checkbox"/>	<input type="checkbox"/>	Wide >10m	<input type="checkbox"/>	<input type="checkbox"/>	Mature Forest, Wetland	<input type="checkbox"/>	<input type="checkbox"/>	Conservation Tillage
<input type="checkbox"/>	<input type="checkbox"/>	Moderate 5-10m	<input type="checkbox"/>	<input type="checkbox"/>	Immature Forest, Shrub or Old Field	<input type="checkbox"/>	<input type="checkbox"/>	Urban or Industrial
<input type="checkbox"/>	<input type="checkbox"/>	Narrow <5m	<input type="checkbox"/>	<input type="checkbox"/>	Residential, Park, New Field	<input type="checkbox"/>	<input type="checkbox"/>	Open Pasture, Row Crop
<input type="checkbox"/>	<input type="checkbox"/>	None	<input type="checkbox"/>	<input type="checkbox"/>	Fenced Pasture	<input type="checkbox"/>	<input type="checkbox"/>	Mining or Construction

COMMENTS \_\_\_\_\_

**FLOW REGIME (At Time of Evaluation) (Check ONLY one box):**

<input type="checkbox"/> Stream Flowing	<input type="checkbox"/> Moist Channel, isolated pools, no flow (Intermittent)
<input type="checkbox"/> Subsurface flow with isolated pools (Interstitial)	<input type="checkbox"/> Dry channel, no water (Ephemeral)

COMMENTS \_\_\_\_\_

**SINUOSITY (Number of bends per 61 m (200 ft) of channel) (Check ONLY one box):**

<input type="checkbox"/> None	<input type="checkbox"/> 1.0	<input type="checkbox"/> 2.0	<input type="checkbox"/> 3.0
<input type="checkbox"/> 0.5	<input type="checkbox"/> 1.5	<input type="checkbox"/> 2.5	<input type="checkbox"/> >3

**STREAM GRADIENT ESTIMATE**

Flat (0.5 ft/100 ft)  Flat to Moderate  Moderate (2 ft/100 ft)  Moderate to Severe  Severe (10 ft/100 ft)



**ADDITIONAL STREAM INFORMATION (This Information Must Also be Completed):**

**QHEI PERFORMED?** -  Yes  No QHEI Score \_\_\_\_\_ (If Yes, Attach Completed QHEI Form)

**DOWNSTREAM DESIGNATED USE(S)**

- WWH Name: \_\_\_\_\_ Distance from Evaluated Stream \_\_\_\_\_
- CWH Name: \_\_\_\_\_ Distance from Evaluated Stream \_\_\_\_\_
- EWH Name: \_\_\_\_\_ Distance from Evaluated Stream \_\_\_\_\_

**MAPPING: ATTACH COPIES OF MAPS, INCLUDING THE ENTIRE WATERSHED AREA. CLEARLY MARK THE SITE LOCATION**

USGS Quadrangle Name: \_\_\_\_\_ NRCS Soil Map Page: \_\_\_\_\_ NRCS Soil Map Stream Order \_\_\_\_\_

County: \_\_\_\_\_ Township / City: \_\_\_\_\_

**MISCELLANEOUS**

Base Flow Conditions? (Y/N): \_\_\_\_\_ Date of last precipitation: \_\_\_\_\_ Quantity: \_\_\_\_\_

Photograph Information: \_\_\_\_\_

Elevated Turbidity? (Y/N): \_\_\_\_\_ Canopy (% open): \_\_\_\_\_

Were samples collected for water chemistry? (Y/N): \_\_\_\_\_ (Note lab sample no. or id. and attach results) Lab Number: \_\_\_\_\_

Field Measures: Temp (°C) \_\_\_\_\_ Dissolved Oxygen (mg/l) \_\_\_\_\_ pH (S.U.) \_\_\_\_\_ Conductivity (µmhos/cm) \_\_\_\_\_

Is the sampling reach representative of the stream (Y/N) \_\_\_\_\_ If not, please explain: \_\_\_\_\_

Additional comments/description of pollution impacts: \_\_\_\_\_

**BIOTIC EVALUATION**

Performed? (Y/N): \_\_\_\_\_ (If Yes, Record all observations. Voucher collections optional. NOTE: all voucher samples must be labeled with the site ID number. Include appropriate field data sheets from the Primary Headwater Habitat Assessment Manual)

Fish Observed? (Y/N) \_\_\_\_\_ Voucher? (Y/N) \_\_\_\_\_ Salamanders Observed? (Y/N) \_\_\_\_\_ Voucher? (Y/N) \_\_\_\_\_  
Frogs or Tadpoles Observed? (Y/N) \_\_\_\_\_ Voucher? (Y/N) \_\_\_\_\_ Aquatic Macroinvertebrates Observed? (Y/N) \_\_\_\_\_ Voucher? (Y/N) \_\_\_\_\_

Comments Regarding Biology: \_\_\_\_\_

**DRAWING AND NARRATIVE DESCRIPTION OF STREAM REACH (This must be completed):**

Include important landmarks and other features of interest for site evaluation and a narrative description of the stream's location

FLOW 



# Primary Headwater Habitat Evaluation Form

HHEI Score (sum of metrics 1, 2, 3) :

SITE NAME/LOCATION \_\_\_\_\_  
 \_\_\_\_\_ SITE NUMBER \_\_\_\_\_ RIVER BASIN \_\_\_\_\_ DRAINAGE AREA (mi<sup>2</sup>) \_\_\_\_\_  
 LENGTH OF STREAM REACH (ft) \_\_\_\_\_ LAT. \_\_\_\_\_ LONG. \_\_\_\_\_ RIVER CODE \_\_\_\_\_ RIVER MILE \_\_\_\_\_  
 DATE \_\_\_\_\_ SCORER \_\_\_\_\_ COMMENTS \_\_\_\_\_

**NOTE: Complete All Items On This Form - Refer to "Field Evaluation Manual for Ohio's PWH Streams" for Instructions**

**STREAM CHANNEL MODIFICATIONS:**

NONE / NATURAL CHANNEL  RECOVERED  RECOVERING  RECENT OR NO RECOVERY

**1. SUBSTRATE (Estimate percent of every type of substrate present. Check ONLY two predominant substrate TYPE boxes (Max of 32). Add total number of significant substrate types found (Max of 8). Final metric score is sum of boxes A & B.**

TYPE	PERCENT	TYPE	PERCENT
<input type="checkbox"/> <input type="checkbox"/> BLDR SLABS [16 pts]	_____	<input type="checkbox"/> <input type="checkbox"/> SILT [3 pt]	_____
<input type="checkbox"/> <input type="checkbox"/> BOULDER (>256 mm) [16 pts]	_____	<input type="checkbox"/> <input type="checkbox"/> LEAF PACK/WOODY DEBRIS [3 pts]	_____
<input type="checkbox"/> <input type="checkbox"/> BEDROCK [16 pt]	_____	<input type="checkbox"/> <input type="checkbox"/> FINE DETRITUS [3 pts]	_____
<input type="checkbox"/> <input type="checkbox"/> COBBLE (65-256 mm) [12 pts]	_____	<input type="checkbox"/> <input type="checkbox"/> CLAY or HARDPAN [0 pt]	_____
<input type="checkbox"/> <input type="checkbox"/> GRAVEL (2-64 mm) [9 pts]	_____	<input type="checkbox"/> <input type="checkbox"/> MUCK [0 pts]	_____
<input type="checkbox"/> <input type="checkbox"/> SAND (<2 mm) [6 pts]	_____	<input type="checkbox"/> <input type="checkbox"/> ARTIFICIAL [3 pts]	_____

Total of Percentages of Bldr Slabs, Boulder, Cobble, Bedrock \_\_\_\_\_

(A)

Substrate Percentage Check

(B)

SCORE OF TWO MOST PREDOMINATE SUBSTRATE TYPES:

TOTAL NUMBER OF SUBSTRATE TYPES:

### HHEI Metric Points

Substrate Max = 40

A + B

**2. Maximum Pool Depth (Measure the maximum pool depth within the 61 meter (200 ft) evaluation reach at the time of evaluation. Avoid plunge pools from road culverts or storm water pipes) (Check ONLY one box):**

<input type="checkbox"/> > 30 centimeters [20 pts]	<input type="checkbox"/> > 5 cm - 10 cm [15 pts]
<input type="checkbox"/> > 22.5 - 30 cm [30 pts]	<input type="checkbox"/> < 5 cm [5 pts]
<input type="checkbox"/> > 10 - 22.5 cm [25 pts]	<input type="checkbox"/> NO WATER OR MOIST CHANNEL [0 pts]

COMMENTS \_\_\_\_\_ MAXIMUM POOL DEPTH (centimeters):

Pool Depth Max = 30

**3. BANK FULL WIDTH (Measured as the average of 3-4 measurements) (Check ONLY one box):**

<input type="checkbox"/> > 4.0 meters (> 13') [30 pts]	<input type="checkbox"/> > 1.0 m - 1.5 m (> 3' 3" - 4' 8") [15 pts]
<input type="checkbox"/> > 3.0 m - 4.0 m (> 9' 7" - 13') [25 pts]	<input type="checkbox"/> ≤ 1.0 m (≤ 3' 3") [5 pts]
<input type="checkbox"/> > 1.5 m - 3.0 m (> 9' 7" - 4' 8") [20 pts]	

COMMENTS \_\_\_\_\_ AVERAGE BANKFULL WIDTH (meters):

Bankfull Width Max=30

**This information must also be completed**

**RIPARIAN ZONE AND FLOODPLAIN QUALITY** ☆NOTE: River Left (L) and Right (R) as looking downstream ☆

RIPARIAN WIDTH

L	R	(Per Bank)
<input type="checkbox"/>	<input type="checkbox"/>	Wide >10m
<input type="checkbox"/>	<input type="checkbox"/>	Moderate 5-10m
<input type="checkbox"/>	<input type="checkbox"/>	Narrow <5m
<input type="checkbox"/>	<input type="checkbox"/>	None

COMMENTS \_\_\_\_\_

FLOODPLAIN QUALITY

L	R	(Most Predominant per Bank)
<input type="checkbox"/>	<input type="checkbox"/>	Mature Forest, Wetland
<input type="checkbox"/>	<input type="checkbox"/>	Immature Forest, Shrub or Old Field
<input type="checkbox"/>	<input type="checkbox"/>	Residential, Park, New Field
<input type="checkbox"/>	<input type="checkbox"/>	Fenced Pasture

L	R	
<input type="checkbox"/>	<input type="checkbox"/>	Conservation Tillage
<input type="checkbox"/>	<input type="checkbox"/>	Urban or Industrial
<input type="checkbox"/>	<input type="checkbox"/>	Open Pasture, Row Crop
<input type="checkbox"/>	<input type="checkbox"/>	Mining or Construction

**FLOW REGIME (At Time of Evaluation) (Check ONLY one box):**

<input type="checkbox"/> Stream Flowing	<input type="checkbox"/> Moist Channel, isolated pools, no flow (Intermittent)
<input type="checkbox"/> Subsurface flow with isolated pools (Interstitial)	<input type="checkbox"/> Dry channel, no water (Ephemeral)

COMMENTS \_\_\_\_\_

**SINUOSITY (Number of bends per 61 m (200 ft) of channel) (Check ONLY one box):**

<input type="checkbox"/> None	<input type="checkbox"/> 1.0	<input type="checkbox"/> 2.0	<input type="checkbox"/> 3.0
<input type="checkbox"/> 0.5	<input type="checkbox"/> 1.5	<input type="checkbox"/> 2.5	<input type="checkbox"/> >3

**STREAM GRADIENT ESTIMATE**

Flat (0.5 ft/100 ft)  Flat to Moderate  Moderate (2 ft/100 ft)  Moderate to Severe  Severe (10 ft/100 ft)

**ADDITIONAL STREAM INFORMATION (This Information Must Also be Completed):**

**QHEI PERFORMED?** -  Yes  No QHEI Score \_\_\_\_\_ (If Yes, Attach Completed QHEI Form)

**DOWNSTREAM DESIGNATED USE(S)**

- WWH Name: \_\_\_\_\_ Distance from Evaluated Stream \_\_\_\_\_
- CWH Name: \_\_\_\_\_ Distance from Evaluated Stream \_\_\_\_\_
- EWH Name: \_\_\_\_\_ Distance from Evaluated Stream \_\_\_\_\_

**MAPPING: ATTACH COPIES OF MAPS, INCLUDING THE ENTIRE WATERSHED AREA. CLEARLY MARK THE SITE LOCATION**

USGS Quadrangle Name: \_\_\_\_\_ NRCS Soil Map Page: \_\_\_\_\_ NRCS Soil Map Stream Order \_\_\_\_\_

County: \_\_\_\_\_ Township / City: \_\_\_\_\_

**MISCELLANEOUS**

Base Flow Conditions? (Y/N): \_\_\_\_\_ Date of last precipitation: \_\_\_\_\_ Quantity: \_\_\_\_\_

Photograph Information: \_\_\_\_\_

Elevated Turbidity? (Y/N): \_\_\_\_\_ Canopy (% open): \_\_\_\_\_

Were samples collected for water chemistry? (Y/N): \_\_\_\_\_ (Note lab sample no. or id. and attach results) Lab Number: \_\_\_\_\_

Field Measures: Temp (°C) \_\_\_\_\_ Dissolved Oxygen (mg/l) \_\_\_\_\_ pH (S.U.) \_\_\_\_\_ Conductivity (µmhos/cm) \_\_\_\_\_

Is the sampling reach representative of the stream (Y/N) \_\_\_\_\_ If not, please explain: \_\_\_\_\_

Additional comments/description of pollution impacts: \_\_\_\_\_

**BIOTIC EVALUATION**

Performed? (Y/N): \_\_\_\_\_ (If Yes, Record all observations. Voucher collections optional. NOTE: all voucher samples must be labeled with the site ID number. Include appropriate field data sheets from the Primary Headwater Habitat Assessment Manual)

Fish Observed? (Y/N) \_\_\_\_\_ Voucher? (Y/N) \_\_\_\_\_ Salamanders Observed? (Y/N) \_\_\_\_\_ Voucher? (Y/N) \_\_\_\_\_  
Frogs or Tadpoles Observed? (Y/N) \_\_\_\_\_ Voucher? (Y/N) \_\_\_\_\_ Aquatic Macroinvertebrates Observed? (Y/N) \_\_\_\_\_ Voucher? (Y/N) \_\_\_\_\_

Comments Regarding Biology: \_\_\_\_\_

**DRAWING AND NARRATIVE DESCRIPTION OF STREAM REACH (This must be completed):**

Include important landmarks and other features of interest for site evaluation and a narrative description of the stream's location

FLOW 



# Primary Headwater Habitat Evaluation Form

HHEI Score (sum of metrics 1, 2, 3) :

SITE NAME/LOCATION \_\_\_\_\_  
 \_\_\_\_\_ SITE NUMBER \_\_\_\_\_ RIVER BASIN \_\_\_\_\_ DRAINAGE AREA (mi<sup>2</sup>) \_\_\_\_\_  
 LENGTH OF STREAM REACH (ft) \_\_\_\_\_ LAT. \_\_\_\_\_ LONG. \_\_\_\_\_ RIVER CODE \_\_\_\_\_ RIVER MILE \_\_\_\_\_  
 DATE \_\_\_\_\_ SCORER \_\_\_\_\_ COMMENTS \_\_\_\_\_

**NOTE: Complete All Items On This Form - Refer to "Field Evaluation Manual for Ohio's PWH Streams" for Instructions**

**STREAM CHANNEL MODIFICATIONS:**

NONE / NATURAL CHANNEL  RECOVERED  RECOVERING  RECENT OR NO RECOVERY

**1. SUBSTRATE (Estimate percent of every type of substrate present. Check ONLY two predominant substrate TYPE boxes (Max of 32). Add total number of significant substrate types found (Max of 8). Final metric score is sum of boxes A & B.**

TYPE	PERCENT	TYPE	PERCENT
<input type="checkbox"/> <input type="checkbox"/> BLDR SLABS [16 pts]	_____	<input type="checkbox"/> <input type="checkbox"/> SILT [3 pt]	_____
<input type="checkbox"/> <input type="checkbox"/> BOULDER (>256 mm) [16 pts]	_____	<input type="checkbox"/> <input type="checkbox"/> LEAF PACK/WOODY DEBRIS [3 pts]	_____
<input type="checkbox"/> <input type="checkbox"/> BEDROCK [16 pt]	_____	<input type="checkbox"/> <input type="checkbox"/> FINE DETRITUS [3 pts]	_____
<input type="checkbox"/> <input type="checkbox"/> COBBLE (65-256 mm) [12 pts]	_____	<input type="checkbox"/> <input type="checkbox"/> CLAY or HARDPAN [0 pt]	_____
<input type="checkbox"/> <input type="checkbox"/> GRAVEL (2-64 mm) [9 pts]	_____	<input type="checkbox"/> <input type="checkbox"/> MUCK [0 pts]	_____
<input type="checkbox"/> <input type="checkbox"/> SAND (<2 mm) [6 pts]	_____	<input type="checkbox"/> <input type="checkbox"/> ARTIFICIAL [3 pts]	_____

Total of Percentages of Bldr Slabs, Boulder, Cobble, Bedrock \_\_\_\_\_

(A)

Substrate Percentage Check

(B)

SCORE OF TWO MOST PREDOMINATE SUBSTRATE TYPES:

TOTAL NUMBER OF SUBSTRATE TYPES:

**HHEI Metric Points**

Substrate Max = 40

A + B

**2. Maximum Pool Depth (Measure the maximum pool depth within the 61 meter (200 ft) evaluation reach at the time of evaluation. Avoid plunge pools from road culverts or storm water pipes) (Check ONLY one box):**

<input type="checkbox"/> > 30 centimeters [20 pts]	<input type="checkbox"/> > 5 cm - 10 cm [15 pts]
<input type="checkbox"/> > 22.5 - 30 cm [30 pts]	<input type="checkbox"/> < 5 cm [5 pts]
<input type="checkbox"/> > 10 - 22.5 cm [25 pts]	<input type="checkbox"/> NO WATER OR MOIST CHANNEL [0 pts]

COMMENTS \_\_\_\_\_ MAXIMUM POOL DEPTH (centimeters):

Pool Depth Max = 30

**3. BANK FULL WIDTH (Measured as the average of 3-4 measurements) (Check ONLY one box):**

<input type="checkbox"/> > 4.0 meters (> 13') [30 pts]	<input type="checkbox"/> > 1.0 m - 1.5 m (> 3' 3" - 4' 8") [15 pts]
<input type="checkbox"/> > 3.0 m - 4.0 m (> 9' 7" - 13') [25 pts]	<input type="checkbox"/> ≤ 1.0 m (≤ 3' 3") [5 pts]
<input type="checkbox"/> > 1.5 m - 3.0 m (> 9' 7" - 4' 8") [20 pts]	

COMMENTS \_\_\_\_\_ AVERAGE BANKFULL WIDTH (meters):

Bankfull Width Max=30

**This information must also be completed**

**RIPARIAN ZONE AND FLOODPLAIN QUALITY** ☆NOTE: River Left (L) and Right (R) as looking downstream ☆

RIPARIAN WIDTH

L	R	(Per Bank)
<input type="checkbox"/>	<input type="checkbox"/>	Wide >10m
<input type="checkbox"/>	<input type="checkbox"/>	Moderate 5-10m
<input type="checkbox"/>	<input type="checkbox"/>	Narrow <5m
<input type="checkbox"/>	<input type="checkbox"/>	None

COMMENTS \_\_\_\_\_

FLOODPLAIN QUALITY

L	R	(Most Predominant per Bank)
<input type="checkbox"/>	<input type="checkbox"/>	Mature Forest, Wetland
<input type="checkbox"/>	<input type="checkbox"/>	Immature Forest, Shrub or Old Field
<input type="checkbox"/>	<input type="checkbox"/>	Residential, Park, New Field
<input type="checkbox"/>	<input type="checkbox"/>	Fenced Pasture

L	R	
<input type="checkbox"/>	<input type="checkbox"/>	Conservation Tillage
<input type="checkbox"/>	<input type="checkbox"/>	Urban or Industrial
<input type="checkbox"/>	<input type="checkbox"/>	Open Pasture, Row Crop
<input type="checkbox"/>	<input type="checkbox"/>	Mining or Construction

**FLOW REGIME (At Time of Evaluation) (Check ONLY one box):**

<input type="checkbox"/> Stream Flowing	<input type="checkbox"/> Moist Channel, isolated pools, no flow (Intermittent)
<input type="checkbox"/> Subsurface flow with isolated pools (Interstitial)	<input type="checkbox"/> Dry channel, no water (Ephemeral)

COMMENTS \_\_\_\_\_

**SINUOSITY (Number of bends per 61 m (200 ft) of channel) (Check ONLY one box):**

<input type="checkbox"/> None	<input type="checkbox"/> 1.0	<input type="checkbox"/> 2.0	<input type="checkbox"/> 3.0
<input type="checkbox"/> 0.5	<input type="checkbox"/> 1.5	<input type="checkbox"/> 2.5	<input type="checkbox"/> >3

**STREAM GRADIENT ESTIMATE**

Flat (0.5 ft/100 ft)  Flat to Moderate  Moderate (2 ft/100 ft)  Moderate to Severe  Severe (10 ft/100 ft)

**ADDITIONAL STREAM INFORMATION (This Information Must Also be Completed):**

**QHEI PERFORMED?** -  Yes  No QHEI Score \_\_\_\_\_ (If Yes, Attach Completed QHEI Form)

**DOWNSTREAM DESIGNATED USE(S)**

- WWH Name: \_\_\_\_\_ Distance from Evaluated Stream \_\_\_\_\_
- CWH Name: \_\_\_\_\_ Distance from Evaluated Stream \_\_\_\_\_
- EWH Name: \_\_\_\_\_ Distance from Evaluated Stream \_\_\_\_\_

**MAPPING: ATTACH COPIES OF MAPS, INCLUDING THE ENTIRE WATERSHED AREA. CLEARLY MARK THE SITE LOCATION**

USGS Quadrangle Name: \_\_\_\_\_ NRCS Soil Map Page: \_\_\_\_\_ NRCS Soil Map Stream Order \_\_\_\_\_

County: \_\_\_\_\_ Township / City: \_\_\_\_\_

**MISCELLANEOUS**

Base Flow Conditions? (Y/N): \_\_\_\_\_ Date of last precipitation: \_\_\_\_\_ Quantity: \_\_\_\_\_

Photograph Information: \_\_\_\_\_

Elevated Turbidity? (Y/N): \_\_\_\_\_ Canopy (% open): \_\_\_\_\_

Were samples collected for water chemistry? (Y/N): \_\_\_\_\_ (Note lab sample no. or id. and attach results) Lab Number: \_\_\_\_\_

Field Measures: Temp (°C) \_\_\_\_\_ Dissolved Oxygen (mg/l) \_\_\_\_\_ pH (S.U.) \_\_\_\_\_ Conductivity (µmhos/cm) \_\_\_\_\_

Is the sampling reach representative of the stream (Y/N) \_\_\_\_\_ If not, please explain: \_\_\_\_\_

Additional comments/description of pollution impacts: \_\_\_\_\_

**BIOTIC EVALUATION**

Performed? (Y/N): \_\_\_\_\_ (If Yes, Record all observations. Voucher collections optional. NOTE: all voucher samples must be labeled with the site ID number. Include appropriate field data sheets from the Primary Headwater Habitat Assessment Manual)

Fish Observed? (Y/N) \_\_\_\_\_ Voucher? (Y/N) \_\_\_\_\_ Salamanders Observed? (Y/N) \_\_\_\_\_ Voucher? (Y/N) \_\_\_\_\_  
Frogs or Tadpoles Observed? (Y/N) \_\_\_\_\_ Voucher? (Y/N) \_\_\_\_\_ Aquatic Macroinvertebrates Observed? (Y/N) \_\_\_\_\_ Voucher? (Y/N) \_\_\_\_\_

Comments Regarding Biology: \_\_\_\_\_

**DRAWING AND NARRATIVE DESCRIPTION OF STREAM REACH (This must be completed):**

Include important landmarks and other features of interest for site evaluation and a narrative description of the stream's location

FLOW 



# Primary Headwater Habitat Evaluation Form

HHEI Score (sum of metrics 1, 2, 3) :

SITE NAME/LOCATION \_\_\_\_\_  
 \_\_\_\_\_ SITE NUMBER \_\_\_\_\_ RIVER BASIN \_\_\_\_\_ DRAINAGE AREA (mi<sup>2</sup>) \_\_\_\_\_  
 LENGTH OF STREAM REACH (ft) \_\_\_\_\_ LAT. \_\_\_\_\_ LONG. \_\_\_\_\_ RIVER CODE \_\_\_\_\_ RIVER MILE \_\_\_\_\_  
 DATE \_\_\_\_\_ SCORER \_\_\_\_\_ COMMENTS \_\_\_\_\_

**NOTE: Complete All Items On This Form - Refer to "Field Evaluation Manual for Ohio's PWH Streams" for Instructions**

**STREAM CHANNEL MODIFICATIONS:**

NONE / NATURAL CHANNEL  RECOVERED  RECOVERING  RECENT OR NO RECOVERY

**1. SUBSTRATE (Estimate percent of every type of substrate present. Check ONLY two predominant substrate TYPE boxes (Max of 32). Add total number of significant substrate types found (Max of 8). Final metric score is sum of boxes A & B.**

TYPE	PERCENT	TYPE	PERCENT
<input type="checkbox"/> <input type="checkbox"/> BLDR SLABS [16 pts]	_____	<input type="checkbox"/> <input type="checkbox"/> SILT [3 pt]	_____
<input type="checkbox"/> <input type="checkbox"/> BOULDER (>256 mm) [16 pts]	_____	<input type="checkbox"/> <input type="checkbox"/> LEAF PACK/WOODY DEBRIS [3 pts]	_____
<input type="checkbox"/> <input type="checkbox"/> BEDROCK [16 pt]	_____	<input type="checkbox"/> <input type="checkbox"/> FINE DETRITUS [3 pts]	_____
<input type="checkbox"/> <input type="checkbox"/> COBBLE (65-256 mm) [12 pts]	_____	<input type="checkbox"/> <input type="checkbox"/> CLAY or HARDPAN [0 pt]	_____
<input type="checkbox"/> <input type="checkbox"/> GRAVEL (2-64 mm) [9 pts]	_____	<input type="checkbox"/> <input type="checkbox"/> MUCK [0 pts]	_____
<input type="checkbox"/> <input type="checkbox"/> SAND (<2 mm) [6 pts]	_____	<input type="checkbox"/> <input type="checkbox"/> ARTIFICIAL [3 pts]	_____

Total of Percentages of Bldr Slabs, Boulder, Cobble, Bedrock \_\_\_\_\_

(A)

(B)

SCORE OF TWO MOST PREDOMINATE SUBSTRATE TYPES:

TOTAL NUMBER OF SUBSTRATE TYPES:

**HHEI Metric Points**

Substrate Max = 40

A + B

**2. Maximum Pool Depth (Measure the maximum pool depth within the 61 meter (200 ft) evaluation reach at the time of evaluation. Avoid plunge pools from road culverts or storm water pipes) (Check ONLY one box):**

<input type="checkbox"/> > 30 centimeters [20 pts]	<input type="checkbox"/> > 5 cm - 10 cm [15 pts]
<input type="checkbox"/> > 22.5 - 30 cm [30 pts]	<input type="checkbox"/> < 5 cm [5 pts]
<input type="checkbox"/> > 10 - 22.5 cm [25 pts]	<input type="checkbox"/> NO WATER OR MOIST CHANNEL [0 pts]

COMMENTS \_\_\_\_\_ MAXIMUM POOL DEPTH (centimeters):

Pool Depth Max = 30

**3. BANK FULL WIDTH (Measured as the average of 3-4 measurements) (Check ONLY one box):**

<input type="checkbox"/> > 4.0 meters (> 13') [30 pts]	<input type="checkbox"/> > 1.0 m - 1.5 m (> 3' 3" - 4' 8") [15 pts]
<input type="checkbox"/> > 3.0 m - 4.0 m (> 9' 7" - 13') [25 pts]	<input type="checkbox"/> ≤ 1.0 m (≤ 3' 3") [5 pts]
<input type="checkbox"/> > 1.5 m - 3.0 m (> 9' 7" - 4' 8") [20 pts]	

COMMENTS \_\_\_\_\_ AVERAGE BANKFULL WIDTH (meters):

Bankfull Width Max=30

**This information must also be completed**

**RIPARIAN ZONE AND FLOODPLAIN QUALITY** ☆NOTE: River Left (L) and Right (R) as looking downstream ☆

RIPARIAN WIDTH

L	R	(Per Bank)
<input type="checkbox"/>	<input type="checkbox"/>	Wide >10m
<input type="checkbox"/>	<input type="checkbox"/>	Moderate 5-10m
<input type="checkbox"/>	<input type="checkbox"/>	Narrow <5m
<input type="checkbox"/>	<input type="checkbox"/>	None

COMMENTS \_\_\_\_\_

FLOODPLAIN QUALITY

L	R	(Most Predominant per Bank)
<input type="checkbox"/>	<input type="checkbox"/>	Mature Forest, Wetland
<input type="checkbox"/>	<input type="checkbox"/>	Immature Forest, Shrub or Old Field
<input type="checkbox"/>	<input type="checkbox"/>	Residential, Park, New Field
<input type="checkbox"/>	<input type="checkbox"/>	Fenced Pasture

L	R	
<input type="checkbox"/>	<input type="checkbox"/>	Conservation Tillage
<input type="checkbox"/>	<input type="checkbox"/>	Urban or Industrial
<input type="checkbox"/>	<input type="checkbox"/>	Open Pasture, Row Crop
<input type="checkbox"/>	<input type="checkbox"/>	Mining or Construction

**FLOW REGIME (At Time of Evaluation) (Check ONLY one box):**

<input type="checkbox"/> Stream Flowing	<input type="checkbox"/> Moist Channel, isolated pools, no flow (Intermittent)
<input type="checkbox"/> Subsurface flow with isolated pools (Interstitial)	<input type="checkbox"/> Dry channel, no water (Ephemeral)

COMMENTS \_\_\_\_\_

**SINUOSITY (Number of bends per 61 m (200 ft) of channel) (Check ONLY one box):**

<input type="checkbox"/> None	<input type="checkbox"/> 1.0	<input type="checkbox"/> 2.0	<input type="checkbox"/> 3.0
<input type="checkbox"/> 0.5	<input type="checkbox"/> 1.5	<input type="checkbox"/> 2.5	<input type="checkbox"/> >3

**STREAM GRADIENT ESTIMATE**

Flat (0.5 ft/100 ft)  Flat to Moderate  Moderate (2 ft/100 ft)  Moderate to Severe  Severe (10 ft/100 ft)

**ADDITIONAL STREAM INFORMATION (This Information Must Also be Completed):**

**QHEI PERFORMED?** -  Yes  No QHEI Score \_\_\_\_\_ (If Yes, Attach Completed QHEI Form)

**DOWNSTREAM DESIGNATED USE(S)**

- WWH Name: \_\_\_\_\_ Distance from Evaluated Stream \_\_\_\_\_
- CWH Name: \_\_\_\_\_ Distance from Evaluated Stream \_\_\_\_\_
- EWH Name: \_\_\_\_\_ Distance from Evaluated Stream \_\_\_\_\_

**MAPPING: ATTACH COPIES OF MAPS, INCLUDING THE ENTIRE WATERSHED AREA. CLEARLY MARK THE SITE LOCATION**

USGS Quadrangle Name: \_\_\_\_\_ NRCS Soil Map Page: \_\_\_\_\_ NRCS Soil Map Stream Order \_\_\_\_\_

County: \_\_\_\_\_ Township / City: \_\_\_\_\_

**MISCELLANEOUS**

Base Flow Conditions? (Y/N): \_\_\_\_\_ Date of last precipitation: \_\_\_\_\_ Quantity: \_\_\_\_\_

Photograph Information: \_\_\_\_\_

Elevated Turbidity? (Y/N): \_\_\_\_\_ Canopy (% open): \_\_\_\_\_

Were samples collected for water chemistry? (Y/N): \_\_\_\_\_ (Note lab sample no. or id. and attach results) Lab Number: \_\_\_\_\_

Field Measures: Temp (°C) \_\_\_\_\_ Dissolved Oxygen (mg/l) \_\_\_\_\_ pH (S.U.) \_\_\_\_\_ Conductivity (µmhos/cm) \_\_\_\_\_

Is the sampling reach representative of the stream (Y/N) \_\_\_\_\_ If not, please explain: \_\_\_\_\_

Additional comments/description of pollution impacts: \_\_\_\_\_

**BIOTIC EVALUATION**

Performed? (Y/N): \_\_\_\_\_ (If Yes, Record all observations. Voucher collections optional. NOTE: all voucher samples must be labeled with the site ID number. Include appropriate field data sheets from the Primary Headwater Habitat Assessment Manual)

Fish Observed? (Y/N) \_\_\_\_\_ Voucher? (Y/N) \_\_\_\_\_ Salamanders Observed? (Y/N) \_\_\_\_\_ Voucher? (Y/N) \_\_\_\_\_  
Frogs or Tadpoles Observed? (Y/N) \_\_\_\_\_ Voucher? (Y/N) \_\_\_\_\_ Aquatic Macroinvertebrates Observed? (Y/N) \_\_\_\_\_ Voucher? (Y/N) \_\_\_\_\_

Comments Regarding Biology: \_\_\_\_\_

**DRAWING AND NARRATIVE DESCRIPTION OF STREAM REACH (This must be completed):**

Include important landmarks and other features of interest for site evaluation and a narrative description of the stream's location

FLOW 



# Primary Headwater Habitat Evaluation Form

HHEI Score (sum of metrics 1, 2, 3) :

SITE NAME/LOCATION \_\_\_\_\_

\_\_\_\_\_ SITE NUMBER \_\_\_\_\_ RIVER BASIN \_\_\_\_\_ DRAINAGE AREA (mi<sup>2</sup>) \_\_\_\_\_

LENGTH OF STREAM REACH (ft) \_\_\_\_\_ LAT. \_\_\_\_\_ LONG. \_\_\_\_\_ RIVER CODE \_\_\_\_\_ RIVER MILE \_\_\_\_\_

DATE \_\_\_\_\_ SCORER \_\_\_\_\_ COMMENTS \_\_\_\_\_

**NOTE: Complete All Items On This Form - Refer to "Field Evaluation Manual for Ohio's PWH Streams" for Instructions**

**STREAM CHANNEL MODIFICATIONS:**

NONE / NATURAL CHANNEL  RECOVERED  RECOVERING  RECENT OR NO RECOVERY

**1. SUBSTRATE (Estimate percent of every type of substrate present. Check ONLY two predominant substrate TYPE boxes (Max of 32). Add total number of significant substrate types found (Max of 8). Final metric score is sum of boxes A & B.**

TYPE	PERCENT	TYPE	PERCENT
<input type="checkbox"/> <input type="checkbox"/> BLDR SLABS [16 pts]	_____	<input type="checkbox"/> <input type="checkbox"/> SILT [3 pt]	_____
<input type="checkbox"/> <input type="checkbox"/> BOULDER (>256 mm) [16 pts]	_____	<input type="checkbox"/> <input type="checkbox"/> LEAF PACK/WOODY DEBRIS [3 pts]	_____
<input type="checkbox"/> <input type="checkbox"/> BEDROCK [16 pt]	_____	<input type="checkbox"/> <input type="checkbox"/> FINE DETRITUS [3 pts]	_____
<input type="checkbox"/> <input type="checkbox"/> COBBLE (65-256 mm) [12 pts]	_____	<input type="checkbox"/> <input type="checkbox"/> CLAY or HARDPAN [0 pt]	_____
<input type="checkbox"/> <input type="checkbox"/> GRAVEL (2-64 mm) [9 pts]	_____	<input type="checkbox"/> <input type="checkbox"/> MUCK [0 pts]	_____
<input type="checkbox"/> <input type="checkbox"/> SAND (<2 mm) [6 pts]	_____	<input type="checkbox"/> <input type="checkbox"/> ARTIFICIAL [3 pts]	_____

Total of Percentages of Bldr Slabs, Boulder, Cobble, Bedrock \_\_\_\_\_

(A)

Substrate Percentage Check

(B)

SCORE OF TWO MOST PREDOMINATE SUBSTRATE TYPES:

TOTAL NUMBER OF SUBSTRATE TYPES:

### HHEI Metric Points

Substrate Max = 40

A + B

**2. Maximum Pool Depth (Measure the maximum pool depth within the 61 meter (200 ft) evaluation reach at the time of evaluation. Avoid plunge pools from road culverts or storm water pipes) (Check ONLY one box):**

<input type="checkbox"/> > 30 centimeters [20 pts]	<input type="checkbox"/> > 5 cm - 10 cm [15 pts]
<input type="checkbox"/> > 22.5 - 30 cm [30 pts]	<input type="checkbox"/> < 5 cm [5 pts]
<input type="checkbox"/> > 10 - 22.5 cm [25 pts]	<input type="checkbox"/> NO WATER OR MOIST CHANNEL [0 pts]

COMMENTS \_\_\_\_\_ MAXIMUM POOL DEPTH (centimeters):

Pool Depth Max = 30

**3. BANK FULL WIDTH (Measured as the average of 3-4 measurements) (Check ONLY one box):**

<input type="checkbox"/> > 4.0 meters (> 13') [30 pts]	<input type="checkbox"/> > 1.0 m - 1.5 m (> 3' 3" - 4' 8") [15 pts]
<input type="checkbox"/> > 3.0 m - 4.0 m (> 9' 7" - 13') [25 pts]	<input type="checkbox"/> ≤ 1.0 m (≤ 3' 3") [5 pts]
<input type="checkbox"/> > 1.5 m - 3.0 m (> 9' 7" - 4' 8") [20 pts]	

COMMENTS \_\_\_\_\_ AVERAGE BANKFULL WIDTH (meters):

Bankfull Width Max=30

**This information must also be completed**

**RIPARIAN ZONE AND FLOODPLAIN QUALITY** ☆NOTE: River Left (L) and Right (R) as looking downstream ☆

RIPARIAN WIDTH

L	R	(Per Bank)
<input type="checkbox"/>	<input type="checkbox"/>	Wide >10m
<input type="checkbox"/>	<input type="checkbox"/>	Moderate 5-10m
<input type="checkbox"/>	<input type="checkbox"/>	Narrow <5m
<input type="checkbox"/>	<input type="checkbox"/>	None

COMMENTS \_\_\_\_\_

FLOODPLAIN QUALITY

L	R	(Most Predominant per Bank)
<input type="checkbox"/>	<input type="checkbox"/>	Mature Forest, Wetland
<input type="checkbox"/>	<input type="checkbox"/>	Immature Forest, Shrub or Old Field
<input type="checkbox"/>	<input type="checkbox"/>	Residential, Park, New Field
<input type="checkbox"/>	<input type="checkbox"/>	Fenced Pasture

L	R	
<input type="checkbox"/>	<input type="checkbox"/>	Conservation Tillage
<input type="checkbox"/>	<input type="checkbox"/>	Urban or Industrial
<input type="checkbox"/>	<input type="checkbox"/>	Open Pasture, Row Crop
<input type="checkbox"/>	<input type="checkbox"/>	Mining or Construction

**FLOW REGIME (At Time of Evaluation) (Check ONLY one box):**

<input type="checkbox"/> Stream Flowing	<input type="checkbox"/> Moist Channel, isolated pools, no flow (Intermittent)
<input type="checkbox"/> Subsurface flow with isolated pools (Interstitial)	<input type="checkbox"/> Dry channel, no water (Ephemeral)

COMMENTS \_\_\_\_\_

**SINUOSITY (Number of bends per 61 m (200 ft) of channel) (Check ONLY one box):**

<input type="checkbox"/> None	<input type="checkbox"/> 1.0	<input type="checkbox"/> 2.0	<input type="checkbox"/> 3.0
<input type="checkbox"/> 0.5	<input type="checkbox"/> 1.5	<input type="checkbox"/> 2.5	<input type="checkbox"/> >3

**STREAM GRADIENT ESTIMATE**

Flat (0.5 ft/100 ft)  Flat to Moderate  Moderate (2 ft/100 ft)  Moderate to Severe  Severe (10 ft/100 ft)



**ADDITIONAL STREAM INFORMATION (This Information Must Also be Completed):**

**QHEI PERFORMED?** -  Yes  No QHEI Score \_\_\_\_\_ (If Yes, Attach Completed QHEI Form)

**DOWNSTREAM DESIGNATED USE(S)**

- WWH Name: \_\_\_\_\_ Distance from Evaluated Stream \_\_\_\_\_
- CWH Name: \_\_\_\_\_ Distance from Evaluated Stream \_\_\_\_\_
- EWH Name: \_\_\_\_\_ Distance from Evaluated Stream \_\_\_\_\_

**MAPPING: ATTACH COPIES OF MAPS, INCLUDING THE ENTIRE WATERSHED AREA. CLEARLY MARK THE SITE LOCATION**

USGS Quadrangle Name: \_\_\_\_\_ NRCS Soil Map Page: \_\_\_\_\_ NRCS Soil Map Stream Order \_\_\_\_\_

County: \_\_\_\_\_ Township / City: \_\_\_\_\_

**MISCELLANEOUS**

Base Flow Conditions? (Y/N): \_\_\_\_\_ Date of last precipitation: \_\_\_\_\_ Quantity: \_\_\_\_\_

Photograph Information: \_\_\_\_\_

Elevated Turbidity? (Y/N): \_\_\_\_\_ Canopy (% open): \_\_\_\_\_

Were samples collected for water chemistry? (Y/N): \_\_\_\_\_ (Note lab sample no. or id. and attach results) Lab Number: \_\_\_\_\_

Field Measures: Temp (°C) \_\_\_\_\_ Dissolved Oxygen (mg/l) \_\_\_\_\_ pH (S.U.) \_\_\_\_\_ Conductivity (µmhos/cm) \_\_\_\_\_

Is the sampling reach representative of the stream (Y/N) \_\_\_\_\_ If not, please explain: \_\_\_\_\_

Additional comments/description of pollution impacts: \_\_\_\_\_

**BIOTIC EVALUATION**

Performed? (Y/N): \_\_\_\_\_ (If Yes, Record all observations. Voucher collections optional. NOTE: all voucher samples must be labeled with the site ID number. Include appropriate field data sheets from the Primary Headwater Habitat Assessment Manual)

Fish Observed? (Y/N) \_\_\_\_\_ Voucher? (Y/N) \_\_\_\_\_ Salamanders Observed? (Y/N) \_\_\_\_\_ Voucher? (Y/N) \_\_\_\_\_  
Frogs or Tadpoles Observed? (Y/N) \_\_\_\_\_ Voucher? (Y/N) \_\_\_\_\_ Aquatic Macroinvertebrates Observed? (Y/N) \_\_\_\_\_ Voucher? (Y/N) \_\_\_\_\_

Comments Regarding Biology: \_\_\_\_\_

**DRAWING AND NARRATIVE DESCRIPTION OF STREAM REACH (This must be completed):**

Include important landmarks and other features of interest for site evaluation and a narrative description of the stream's location

FLOW 



# Primary Headwater Habitat Evaluation Form

HHEI Score (sum of metrics 1, 2, 3) :

SITE NAME/LOCATION \_\_\_\_\_  
 \_\_\_\_\_ SITE NUMBER \_\_\_\_\_ RIVER BASIN \_\_\_\_\_ DRAINAGE AREA (mi<sup>2</sup>) \_\_\_\_\_  
 LENGTH OF STREAM REACH (ft) \_\_\_\_\_ LAT. \_\_\_\_\_ LONG. \_\_\_\_\_ RIVER CODE \_\_\_\_\_ RIVER MILE \_\_\_\_\_  
 DATE \_\_\_\_\_ SCORER \_\_\_\_\_ COMMENTS \_\_\_\_\_

**NOTE: Complete All Items On This Form - Refer to "Field Evaluation Manual for Ohio's PWH Streams" for Instructions**

**STREAM CHANNEL MODIFICATIONS:**

NONE / NATURAL CHANNEL  RECOVERED  RECOVERING  RECENT OR NO RECOVERY

**1. SUBSTRATE (Estimate percent of every type of substrate present. Check ONLY two predominant substrate TYPE boxes (Max of 32). Add total number of significant substrate types found (Max of 8). Final metric score is sum of boxes A & B.**

TYPE	PERCENT	TYPE	PERCENT
<input type="checkbox"/> <input type="checkbox"/> BLDR SLABS [16 pts]	_____	<input type="checkbox"/> <input type="checkbox"/> SILT [3 pt]	_____
<input type="checkbox"/> <input type="checkbox"/> BOULDER (>256 mm) [16 pts]	_____	<input type="checkbox"/> <input type="checkbox"/> LEAF PACK/WOODY DEBRIS [3 pts]	_____
<input type="checkbox"/> <input type="checkbox"/> BEDROCK [16 pt]	_____	<input type="checkbox"/> <input type="checkbox"/> FINE DETRITUS [3 pts]	_____
<input type="checkbox"/> <input type="checkbox"/> COBBLE (65-256 mm) [12 pts]	_____	<input type="checkbox"/> <input type="checkbox"/> CLAY or HARDPAN [0 pt]	_____
<input type="checkbox"/> <input type="checkbox"/> GRAVEL (2-64 mm) [9 pts]	_____	<input type="checkbox"/> <input type="checkbox"/> MUCK [0 pts]	_____
<input type="checkbox"/> <input type="checkbox"/> SAND (<2 mm) [6 pts]	_____	<input type="checkbox"/> <input type="checkbox"/> ARTIFICIAL [3 pts]	_____

Total of Percentages of Bldr Slabs, Boulder, Cobble, Bedrock \_\_\_\_\_

(A)

(B)

SCORE OF TWO MOST PREDOMINATE SUBSTRATE TYPES:

TOTAL NUMBER OF SUBSTRATE TYPES:

**HHEI Metric Points**

Substrate Max = 40

A + B

**2. Maximum Pool Depth (Measure the maximum pool depth within the 61 meter (200 ft) evaluation reach at the time of evaluation. Avoid plunge pools from road culverts or storm water pipes) (Check ONLY one box):**

<input type="checkbox"/> > 30 centimeters [20 pts]	<input type="checkbox"/> > 5 cm - 10 cm [15 pts]
<input type="checkbox"/> > 22.5 - 30 cm [30 pts]	<input type="checkbox"/> < 5 cm [5 pts]
<input type="checkbox"/> > 10 - 22.5 cm [25 pts]	<input type="checkbox"/> NO WATER OR MOIST CHANNEL [0 pts]

COMMENTS \_\_\_\_\_ MAXIMUM POOL DEPTH (centimeters):

Pool Depth Max = 30

**3. BANK FULL WIDTH (Measured as the average of 3-4 measurements) (Check ONLY one box):**

<input type="checkbox"/> > 4.0 meters (> 13') [30 pts]	<input type="checkbox"/> > 1.0 m - 1.5 m (> 3' 3" - 4' 8") [15 pts]
<input type="checkbox"/> > 3.0 m - 4.0 m (> 9' 7" - 13') [25 pts]	<input type="checkbox"/> ≤ 1.0 m (≤ 3' 3") [5 pts]
<input type="checkbox"/> > 1.5 m - 3.0 m (> 9' 7" - 4' 8") [20 pts]	

COMMENTS \_\_\_\_\_ AVERAGE BANKFULL WIDTH (meters):

Bankfull Width Max=30

**This information must also be completed**

**RIPARIAN ZONE AND FLOODPLAIN QUALITY** ☆NOTE: River Left (L) and Right (R) as looking downstream ☆

RIPARIAN WIDTH

L	R	(Per Bank)
<input type="checkbox"/>	<input type="checkbox"/>	Wide >10m
<input type="checkbox"/>	<input type="checkbox"/>	Moderate 5-10m
<input type="checkbox"/>	<input type="checkbox"/>	Narrow <5m
<input type="checkbox"/>	<input type="checkbox"/>	None

COMMENTS \_\_\_\_\_

FLOODPLAIN QUALITY

L	R	(Most Predominant per Bank)	L	R	
<input type="checkbox"/>	<input type="checkbox"/>	Mature Forest, Wetland	<input type="checkbox"/>	<input type="checkbox"/>	Conservation Tillage
<input type="checkbox"/>	<input type="checkbox"/>	Immature Forest, Shrub or Old Field	<input type="checkbox"/>	<input type="checkbox"/>	Urban or Industrial
<input type="checkbox"/>	<input type="checkbox"/>	Residential, Park, New Field	<input type="checkbox"/>	<input type="checkbox"/>	Open Pasture, Row Crop
<input type="checkbox"/>	<input type="checkbox"/>	Fenced Pasture	<input type="checkbox"/>	<input type="checkbox"/>	Mining or Construction

**FLOW REGIME (At Time of Evaluation) (Check ONLY one box):**

<input type="checkbox"/> Stream Flowing	<input type="checkbox"/> Moist Channel, isolated pools, no flow (Intermittent)
<input type="checkbox"/> Subsurface flow with isolated pools (Interstitial)	<input type="checkbox"/> Dry channel, no water (Ephemeral)

COMMENTS \_\_\_\_\_

**SINUOSITY (Number of bends per 61 m (200 ft) of channel) (Check ONLY one box):**

<input type="checkbox"/> None	<input type="checkbox"/> 1.0	<input type="checkbox"/> 2.0	<input type="checkbox"/> 3.0
<input type="checkbox"/> 0.5	<input type="checkbox"/> 1.5	<input type="checkbox"/> 2.5	<input type="checkbox"/> >3

**STREAM GRADIENT ESTIMATE**

Flat (0.5 ft/100 ft)  Flat to Moderate  Moderate (2 ft/100 ft)  Moderate to Severe  Severe (10 ft/100 ft)

**ADDITIONAL STREAM INFORMATION (This Information Must Also be Completed):**

**QHEI PERFORMED?** -  Yes  No QHEI Score \_\_\_\_\_ (If Yes, Attach Completed QHEI Form)

**DOWNSTREAM DESIGNATED USE(S)**

- WWH Name: \_\_\_\_\_ Distance from Evaluated Stream \_\_\_\_\_
- CWH Name: \_\_\_\_\_ Distance from Evaluated Stream \_\_\_\_\_
- EWH Name: \_\_\_\_\_ Distance from Evaluated Stream \_\_\_\_\_

**MAPPING: ATTACH COPIES OF MAPS, INCLUDING THE ENTIRE WATERSHED AREA. CLEARLY MARK THE SITE LOCATION**

USGS Quadrangle Name: \_\_\_\_\_ NRCS Soil Map Page: \_\_\_\_\_ NRCS Soil Map Stream Order \_\_\_\_\_

County: \_\_\_\_\_ Township / City: \_\_\_\_\_

**MISCELLANEOUS**

Base Flow Conditions? (Y/N): \_\_\_\_\_ Date of last precipitation: \_\_\_\_\_ Quantity: \_\_\_\_\_

Photograph Information: \_\_\_\_\_

Elevated Turbidity? (Y/N): \_\_\_\_\_ Canopy (% open): \_\_\_\_\_

Were samples collected for water chemistry? (Y/N): \_\_\_\_\_ (Note lab sample no. or id. and attach results) Lab Number: \_\_\_\_\_

Field Measures: Temp (°C) \_\_\_\_\_ Dissolved Oxygen (mg/l) \_\_\_\_\_ pH (S.U.) \_\_\_\_\_ Conductivity (µmhos/cm) \_\_\_\_\_

Is the sampling reach representative of the stream (Y/N) \_\_\_\_\_ If not, please explain: \_\_\_\_\_

Additional comments/description of pollution impacts: \_\_\_\_\_

**BIOTIC EVALUATION**

Performed? (Y/N): \_\_\_\_\_ (If Yes, Record all observations. Voucher collections optional. NOTE: all voucher samples must be labeled with the site ID number. Include appropriate field data sheets from the Primary Headwater Habitat Assessment Manual)

Fish Observed? (Y/N) \_\_\_\_\_ Voucher? (Y/N) \_\_\_\_\_ Salamanders Observed? (Y/N) \_\_\_\_\_ Voucher? (Y/N) \_\_\_\_\_  
Frogs or Tadpoles Observed? (Y/N) \_\_\_\_\_ Voucher? (Y/N) \_\_\_\_\_ Aquatic Macroinvertebrates Observed? (Y/N) \_\_\_\_\_ Voucher? (Y/N) \_\_\_\_\_

Comments Regarding Biology: \_\_\_\_\_

**DRAWING AND NARRATIVE DESCRIPTION OF STREAM REACH (This must be completed):**

Include important landmarks and other features of interest for site evaluation and a narrative description of the stream's location

FLOW 



# Primary Headwater Habitat Evaluation Form

HHEI Score (sum of metrics 1, 2, 3) :

SITE NAME/LOCATION \_\_\_\_\_  
 \_\_\_\_\_ SITE NUMBER \_\_\_\_\_ RIVER BASIN \_\_\_\_\_ DRAINAGE AREA (mi<sup>2</sup>) \_\_\_\_\_  
 LENGTH OF STREAM REACH (ft) \_\_\_\_\_ LAT. \_\_\_\_\_ LONG. \_\_\_\_\_ RIVER CODE \_\_\_\_\_ RIVER MILE \_\_\_\_\_  
 DATE \_\_\_\_\_ SCORER \_\_\_\_\_ COMMENTS \_\_\_\_\_

**NOTE: Complete All Items On This Form - Refer to "Field Evaluation Manual for Ohio's PWH Streams" for Instructions**

**STREAM CHANNEL MODIFICATIONS:**

NONE / NATURAL CHANNEL  RECOVERED  RECOVERING  RECENT OR NO RECOVERY

**1. SUBSTRATE (Estimate percent of every type of substrate present. Check ONLY two predominant substrate TYPE boxes (Max of 32). Add total number of significant substrate types found (Max of 8). Final metric score is sum of boxes A & B.**

TYPE	PERCENT	TYPE	PERCENT
<input type="checkbox"/> <input type="checkbox"/> BLDR SLABS [16 pts]	_____	<input type="checkbox"/> <input type="checkbox"/> SILT [3 pt]	_____
<input type="checkbox"/> <input type="checkbox"/> BOULDER (>256 mm) [16 pts]	_____	<input type="checkbox"/> <input type="checkbox"/> LEAF PACK/WOODY DEBRIS [3 pts]	_____
<input type="checkbox"/> <input type="checkbox"/> BEDROCK [16 pt]	_____	<input type="checkbox"/> <input type="checkbox"/> FINE DETRITUS [3 pts]	_____
<input type="checkbox"/> <input type="checkbox"/> COBBLE (65-256 mm) [12 pts]	_____	<input type="checkbox"/> <input type="checkbox"/> CLAY or HARDPAN [0 pt]	_____
<input type="checkbox"/> <input type="checkbox"/> GRAVEL (2-64 mm) [9 pts]	_____	<input type="checkbox"/> <input type="checkbox"/> MUCK [0 pts]	_____
<input type="checkbox"/> <input type="checkbox"/> SAND (<2 mm) [6 pts]	_____	<input type="checkbox"/> <input type="checkbox"/> ARTIFICIAL [3 pts]	_____

Total of Percentages of Bldr Slabs, Boulder, Cobble, Bedrock \_\_\_\_\_

(A)

Substrate Percentage Check

(B)

SCORE OF TWO MOST PREDOMINATE SUBSTRATE TYPES:

TOTAL NUMBER OF SUBSTRATE TYPES:

### HHEI Metric Points

Substrate Max = 40

A + B

**2. Maximum Pool Depth (Measure the maximum pool depth within the 61 meter (200 ft) evaluation reach at the time of evaluation. Avoid plunge pools from road culverts or storm water pipes) (Check ONLY one box):**

<input type="checkbox"/> > 30 centimeters [20 pts]	<input type="checkbox"/> > 5 cm - 10 cm [15 pts]
<input type="checkbox"/> > 22.5 - 30 cm [30 pts]	<input type="checkbox"/> < 5 cm [5 pts]
<input type="checkbox"/> > 10 - 22.5 cm [25 pts]	<input type="checkbox"/> NO WATER OR MOIST CHANNEL [0 pts]

COMMENTS \_\_\_\_\_ MAXIMUM POOL DEPTH (centimeters):

Pool Depth Max = 30

**3. BANK FULL WIDTH (Measured as the average of 3-4 measurements) (Check ONLY one box):**

<input type="checkbox"/> > 4.0 meters (> 13') [30 pts]	<input type="checkbox"/> > 1.0 m - 1.5 m (> 3' 3" - 4' 8") [15 pts]
<input type="checkbox"/> > 3.0 m - 4.0 m (> 9' 7" - 13') [25 pts]	<input type="checkbox"/> ≤ 1.0 m (≤ 3' 3") [5 pts]
<input type="checkbox"/> > 1.5 m - 3.0 m (> 9' 7" - 4' 8") [20 pts]	

COMMENTS \_\_\_\_\_ AVERAGE BANKFULL WIDTH (meters):

Bankfull Width Max=30

**This information must also be completed**

**RIPARIAN ZONE AND FLOODPLAIN QUALITY** ☆NOTE: River Left (L) and Right (R) as looking downstream ☆

RIPARIAN WIDTH

L	R	(Per Bank)
<input type="checkbox"/>	<input type="checkbox"/>	Wide >10m
<input type="checkbox"/>	<input type="checkbox"/>	Moderate 5-10m
<input type="checkbox"/>	<input type="checkbox"/>	Narrow <5m
<input type="checkbox"/>	<input type="checkbox"/>	None

COMMENTS \_\_\_\_\_

FLOODPLAIN QUALITY

L	R	(Most Predominant per Bank)
<input type="checkbox"/>	<input type="checkbox"/>	Mature Forest, Wetland
<input type="checkbox"/>	<input type="checkbox"/>	Immature Forest, Shrub or Old Field
<input type="checkbox"/>	<input type="checkbox"/>	Residential, Park, New Field
<input type="checkbox"/>	<input type="checkbox"/>	Fenced Pasture

L	R	
<input type="checkbox"/>	<input type="checkbox"/>	Conservation Tillage
<input type="checkbox"/>	<input type="checkbox"/>	Urban or Industrial
<input type="checkbox"/>	<input type="checkbox"/>	Open Pasture, Row Crop
<input type="checkbox"/>	<input type="checkbox"/>	Mining or Construction

**FLOW REGIME (At Time of Evaluation) (Check ONLY one box):**

<input type="checkbox"/> Stream Flowing	<input type="checkbox"/> Moist Channel, isolated pools, no flow (Intermittent)
<input type="checkbox"/> Subsurface flow with isolated pools (Interstitial)	<input type="checkbox"/> Dry channel, no water (Ephemeral)

COMMENTS \_\_\_\_\_

**SINUOSITY (Number of bends per 61 m (200 ft) of channel) (Check ONLY one box):**

<input type="checkbox"/> None	<input type="checkbox"/> 1.0	<input type="checkbox"/> 2.0	<input type="checkbox"/> 3.0
<input type="checkbox"/> 0.5	<input type="checkbox"/> 1.5	<input type="checkbox"/> 2.5	<input type="checkbox"/> >3

**STREAM GRADIENT ESTIMATE**

Flat (0.5 ft/100 ft)  Flat to Moderate  Moderate (2 ft/100 ft)  Moderate to Severe  Severe (10 ft/100 ft)

**ADDITIONAL STREAM INFORMATION (This Information Must Also be Completed):**

**QHEI PERFORMED?** -  Yes  No QHEI Score \_\_\_\_\_ (If Yes, Attach Completed QHEI Form)

**DOWNSTREAM DESIGNATED USE(S)**

- WWH Name: \_\_\_\_\_ Distance from Evaluated Stream \_\_\_\_\_
- CWH Name: \_\_\_\_\_ Distance from Evaluated Stream \_\_\_\_\_
- EWH Name: \_\_\_\_\_ Distance from Evaluated Stream \_\_\_\_\_

**MAPPING: ATTACH COPIES OF MAPS, INCLUDING THE ENTIRE WATERSHED AREA. CLEARLY MARK THE SITE LOCATION**

USGS Quadrangle Name: \_\_\_\_\_ NRCS Soil Map Page: \_\_\_\_\_ NRCS Soil Map Stream Order \_\_\_\_\_

County: \_\_\_\_\_ Township / City: \_\_\_\_\_

**MISCELLANEOUS**

Base Flow Conditions? (Y/N): \_\_\_\_\_ Date of last precipitation: \_\_\_\_\_ Quantity: \_\_\_\_\_

Photograph Information: \_\_\_\_\_

Elevated Turbidity? (Y/N): \_\_\_\_\_ Canopy (% open): \_\_\_\_\_

Were samples collected for water chemistry? (Y/N): \_\_\_\_\_ (Note lab sample no. or id. and attach results) Lab Number: \_\_\_\_\_

Field Measures: Temp (°C) \_\_\_\_\_ Dissolved Oxygen (mg/l) \_\_\_\_\_ pH (S.U.) \_\_\_\_\_ Conductivity (µmhos/cm) \_\_\_\_\_

Is the sampling reach representative of the stream (Y/N) \_\_\_\_\_ If not, please explain: \_\_\_\_\_

Additional comments/description of pollution impacts: \_\_\_\_\_

**BIOTIC EVALUATION**

Performed? (Y/N): \_\_\_\_\_ (If Yes, Record all observations. Voucher collections optional. NOTE: all voucher samples must be labeled with the site ID number. Include appropriate field data sheets from the Primary Headwater Habitat Assessment Manual)

Fish Observed? (Y/N) \_\_\_\_\_ Voucher? (Y/N) \_\_\_\_\_ Salamanders Observed? (Y/N) \_\_\_\_\_ Voucher? (Y/N) \_\_\_\_\_  
Frogs or Tadpoles Observed? (Y/N) \_\_\_\_\_ Voucher? (Y/N) \_\_\_\_\_ Aquatic Macroinvertebrates Observed? (Y/N) \_\_\_\_\_ Voucher? (Y/N) \_\_\_\_\_

Comments Regarding Biology: \_\_\_\_\_

**DRAWING AND NARRATIVE DESCRIPTION OF STREAM REACH (This must be completed):**

Include important landmarks and other features of interest for site evaluation and a narrative description of the stream's location

FLOW 



# Primary Headwater Habitat Evaluation Form

HHEI Score (sum of metrics 1, 2, 3) :

SITE NAME/LOCATION \_\_\_\_\_  
 \_\_\_\_\_ SITE NUMBER \_\_\_\_\_ RIVER BASIN \_\_\_\_\_ DRAINAGE AREA (mi<sup>2</sup>) \_\_\_\_\_  
 LENGTH OF STREAM REACH (ft) \_\_\_\_\_ LAT. \_\_\_\_\_ LONG. \_\_\_\_\_ RIVER CODE \_\_\_\_\_ RIVER MILE \_\_\_\_\_  
 DATE \_\_\_\_\_ SCORER \_\_\_\_\_ COMMENTS \_\_\_\_\_

**NOTE: Complete All Items On This Form - Refer to "Field Evaluation Manual for Ohio's PWH Streams" for Instructions**

**STREAM CHANNEL MODIFICATIONS:**

NONE / NATURAL CHANNEL  RECOVERED  RECOVERING  RECENT OR NO RECOVERY

**1. SUBSTRATE (Estimate percent of every type of substrate present. Check ONLY two predominant substrate TYPE boxes (Max of 32). Add total number of significant substrate types found (Max of 8). Final metric score is sum of boxes A & B.**

TYPE	PERCENT	TYPE	PERCENT
<input type="checkbox"/> <input type="checkbox"/> BLDR SLABS [16 pts]	_____	<input type="checkbox"/> <input type="checkbox"/> SILT [3 pt]	_____
<input type="checkbox"/> <input type="checkbox"/> BOULDER (>256 mm) [16 pts]	_____	<input type="checkbox"/> <input type="checkbox"/> LEAF PACK/WOODY DEBRIS [3 pts]	_____
<input type="checkbox"/> <input type="checkbox"/> BEDROCK [16 pt]	_____	<input type="checkbox"/> <input type="checkbox"/> FINE DETRITUS [3 pts]	_____
<input type="checkbox"/> <input type="checkbox"/> COBBLE (65-256 mm) [12 pts]	_____	<input type="checkbox"/> <input type="checkbox"/> CLAY or HARDPAN [0 pt]	_____
<input type="checkbox"/> <input type="checkbox"/> GRAVEL (2-64 mm) [9 pts]	_____	<input type="checkbox"/> <input type="checkbox"/> MUCK [0 pts]	_____
<input type="checkbox"/> <input type="checkbox"/> SAND (<2 mm) [6 pts]	_____	<input type="checkbox"/> <input type="checkbox"/> ARTIFICIAL [3 pts]	_____

Total of Percentages of Bldr Slabs, Boulder, Cobble, Bedrock \_\_\_\_\_

(A)

Substrate Percentage Check

(B)

SCORE OF TWO MOST PREDOMINATE SUBSTRATE TYPES:

TOTAL NUMBER OF SUBSTRATE TYPES:

### HHEI Metric Points

Substrate Max = 40

A + B

**2. Maximum Pool Depth (Measure the maximum pool depth within the 61 meter (200 ft) evaluation reach at the time of evaluation. Avoid plunge pools from road culverts or storm water pipes) (Check ONLY one box):**

<input type="checkbox"/> > 30 centimeters [20 pts]	<input type="checkbox"/> > 5 cm - 10 cm [15 pts]
<input type="checkbox"/> > 22.5 - 30 cm [30 pts]	<input type="checkbox"/> < 5 cm [5 pts]
<input type="checkbox"/> > 10 - 22.5 cm [25 pts]	<input type="checkbox"/> NO WATER OR MOIST CHANNEL [0 pts]

COMMENTS \_\_\_\_\_ MAXIMUM POOL DEPTH (centimeters):

Pool Depth Max = 30

**3. BANK FULL WIDTH (Measured as the average of 3-4 measurements) (Check ONLY one box):**

<input type="checkbox"/> > 4.0 meters (> 13') [30 pts]	<input type="checkbox"/> > 1.0 m - 1.5 m (> 3' 3" - 4' 8") [15 pts]
<input type="checkbox"/> > 3.0 m - 4.0 m (> 9' 7" - 13') [25 pts]	<input type="checkbox"/> ≤ 1.0 m (≤ 3' 3") [5 pts]
<input type="checkbox"/> > 1.5 m - 3.0 m (> 9' 7" - 4' 8") [20 pts]	

COMMENTS \_\_\_\_\_ AVERAGE BANKFULL WIDTH (meters):

Bankfull Width Max=30

**This information must also be completed**

**RIPARIAN ZONE AND FLOODPLAIN QUALITY** ☆NOTE: River Left (L) and Right (R) as looking downstream ☆

RIPARIAN WIDTH

L	R	(Per Bank)
<input type="checkbox"/>	<input type="checkbox"/>	Wide >10m
<input type="checkbox"/>	<input type="checkbox"/>	Moderate 5-10m
<input type="checkbox"/>	<input type="checkbox"/>	Narrow <5m
<input type="checkbox"/>	<input type="checkbox"/>	None

COMMENTS \_\_\_\_\_

FLOODPLAIN QUALITY

L	R	(Most Predominant per Bank)
<input type="checkbox"/>	<input type="checkbox"/>	Mature Forest, Wetland
<input type="checkbox"/>	<input type="checkbox"/>	Immature Forest, Shrub or Old Field
<input type="checkbox"/>	<input type="checkbox"/>	Residential, Park, New Field
<input type="checkbox"/>	<input type="checkbox"/>	Fenced Pasture

L	R	
<input type="checkbox"/>	<input type="checkbox"/>	Conservation Tillage
<input type="checkbox"/>	<input type="checkbox"/>	Urban or Industrial
<input type="checkbox"/>	<input type="checkbox"/>	Open Pasture, Row Crop
<input type="checkbox"/>	<input type="checkbox"/>	Mining or Construction

**FLOW REGIME (At Time of Evaluation) (Check ONLY one box):**

<input type="checkbox"/> Stream Flowing	<input type="checkbox"/> Moist Channel, isolated pools, no flow (Intermittent)
<input type="checkbox"/> Subsurface flow with isolated pools (Interstitial)	<input type="checkbox"/> Dry channel, no water (Ephemeral)

COMMENTS \_\_\_\_\_

**SINUOSITY (Number of bends per 61 m (200 ft) of channel) (Check ONLY one box):**

<input type="checkbox"/> None	<input type="checkbox"/> 1.0	<input type="checkbox"/> 2.0	<input type="checkbox"/> 3.0
<input type="checkbox"/> 0.5	<input type="checkbox"/> 1.5	<input type="checkbox"/> 2.5	<input type="checkbox"/> >3

**STREAM GRADIENT ESTIMATE**

Flat (0.5 ft/100 ft)  Flat to Moderate  Moderate (2 ft/100 ft)  Moderate to Severe  Severe (10 ft/100 ft)

**ADDITIONAL STREAM INFORMATION (This Information Must Also be Completed):**

**QHEI PERFORMED?** -  Yes  No QHEI Score \_\_\_\_\_ (If Yes, Attach Completed QHEI Form)

**DOWNSTREAM DESIGNATED USE(S)**

- WWH Name: \_\_\_\_\_ Distance from Evaluated Stream \_\_\_\_\_
- CWH Name: \_\_\_\_\_ Distance from Evaluated Stream \_\_\_\_\_
- EWH Name: \_\_\_\_\_ Distance from Evaluated Stream \_\_\_\_\_

**MAPPING: ATTACH COPIES OF MAPS, INCLUDING THE ENTIRE WATERSHED AREA. CLEARLY MARK THE SITE LOCATION**

USGS Quadrangle Name: \_\_\_\_\_ NRCS Soil Map Page: \_\_\_\_\_ NRCS Soil Map Stream Order \_\_\_\_\_

County: \_\_\_\_\_ Township / City: \_\_\_\_\_

**MISCELLANEOUS**

Base Flow Conditions? (Y/N): \_\_\_\_\_ Date of last precipitation: \_\_\_\_\_ Quantity: \_\_\_\_\_

Photograph Information: \_\_\_\_\_

Elevated Turbidity? (Y/N): \_\_\_\_\_ Canopy (% open): \_\_\_\_\_

Were samples collected for water chemistry? (Y/N): \_\_\_\_\_ (Note lab sample no. or id. and attach results) Lab Number: \_\_\_\_\_

Field Measures: Temp (°C) \_\_\_\_\_ Dissolved Oxygen (mg/l) \_\_\_\_\_ pH (S.U.) \_\_\_\_\_ Conductivity (µmhos/cm) \_\_\_\_\_

Is the sampling reach representative of the stream (Y/N) \_\_\_\_\_ If not, please explain: \_\_\_\_\_

Additional comments/description of pollution impacts: \_\_\_\_\_

**BIOTIC EVALUATION**

Performed? (Y/N): \_\_\_\_\_ (If Yes, Record all observations. Voucher collections optional. NOTE: all voucher samples must be labeled with the site ID number. Include appropriate field data sheets from the Primary Headwater Habitat Assessment Manual)

Fish Observed? (Y/N) \_\_\_\_\_ Voucher? (Y/N) \_\_\_\_\_ Salamanders Observed? (Y/N) \_\_\_\_\_ Voucher? (Y/N) \_\_\_\_\_  
Frogs or Tadpoles Observed? (Y/N) \_\_\_\_\_ Voucher? (Y/N) \_\_\_\_\_ Aquatic Macroinvertebrates Observed? (Y/N) \_\_\_\_\_ Voucher? (Y/N) \_\_\_\_\_

Comments Regarding Biology: \_\_\_\_\_

**DRAWING AND NARRATIVE DESCRIPTION OF STREAM REACH (This must be completed):**

Include important landmarks and other features of interest for site evaluation and a narrative description of the stream's location

FLOW 



# Primary Headwater Habitat Evaluation Form

HHEI Score (sum of metrics 1, 2, 3) :

SITE NAME/LOCATION \_\_\_\_\_  
 \_\_\_\_\_ SITE NUMBER \_\_\_\_\_ RIVER BASIN \_\_\_\_\_ DRAINAGE AREA (mi<sup>2</sup>) \_\_\_\_\_  
 LENGTH OF STREAM REACH (ft) \_\_\_\_\_ LAT. \_\_\_\_\_ LONG. \_\_\_\_\_ RIVER CODE \_\_\_\_\_ RIVER MILE \_\_\_\_\_  
 DATE \_\_\_\_\_ SCORER \_\_\_\_\_ COMMENTS \_\_\_\_\_

**NOTE: Complete All Items On This Form - Refer to "Field Evaluation Manual for Ohio's PWH Streams" for Instructions**

**STREAM CHANNEL MODIFICATIONS:**

NONE / NATURAL CHANNEL  RECOVERED  RECOVERING  RECENT OR NO RECOVERY

**1. SUBSTRATE (Estimate percent of every type of substrate present. Check ONLY two predominant substrate TYPE boxes (Max of 32). Add total number of significant substrate types found (Max of 8). Final metric score is sum of boxes A & B.**

TYPE	PERCENT	TYPE	PERCENT
<input type="checkbox"/> <input type="checkbox"/> BLDR SLABS [16 pts]	_____	<input type="checkbox"/> <input type="checkbox"/> SILT [3 pt]	_____
<input type="checkbox"/> <input type="checkbox"/> BOULDER (>256 mm) [16 pts]	_____	<input type="checkbox"/> <input type="checkbox"/> LEAF PACK/WOODY DEBRIS [3 pts]	_____
<input type="checkbox"/> <input type="checkbox"/> BEDROCK [16 pt]	_____	<input type="checkbox"/> <input type="checkbox"/> FINE DETRITUS [3 pts]	_____
<input type="checkbox"/> <input type="checkbox"/> COBBLE (65-256 mm) [12 pts]	_____	<input type="checkbox"/> <input type="checkbox"/> CLAY or HARDPAN [0 pt]	_____
<input type="checkbox"/> <input type="checkbox"/> GRAVEL (2-64 mm) [9 pts]	_____	<input type="checkbox"/> <input type="checkbox"/> MUCK [0 pts]	_____
<input type="checkbox"/> <input type="checkbox"/> SAND (<2 mm) [6 pts]	_____	<input type="checkbox"/> <input type="checkbox"/> ARTIFICIAL [3 pts]	_____

Total of Percentages of Bldr Slabs, Boulder, Cobble, Bedrock \_\_\_\_\_

(A)

Substrate Percentage Check

(B)

SCORE OF TWO MOST PREDOMINATE SUBSTRATE TYPES:

TOTAL NUMBER OF SUBSTRATE TYPES:

**HHEI Metric Points**

Substrate Max = 40

A + B

**2. Maximum Pool Depth (Measure the maximum pool depth within the 61 meter (200 ft) evaluation reach at the time of evaluation. Avoid plunge pools from road culverts or storm water pipes) (Check ONLY one box):**

<input type="checkbox"/> > 30 centimeters [20 pts]	<input type="checkbox"/> > 5 cm - 10 cm [15 pts]
<input type="checkbox"/> > 22.5 - 30 cm [30 pts]	<input type="checkbox"/> < 5 cm [5 pts]
<input type="checkbox"/> > 10 - 22.5 cm [25 pts]	<input type="checkbox"/> NO WATER OR MOIST CHANNEL [0 pts]

COMMENTS \_\_\_\_\_ MAXIMUM POOL DEPTH (centimeters):

Pool Depth Max = 30

**3. BANK FULL WIDTH (Measured as the average of 3-4 measurements) (Check ONLY one box):**

<input type="checkbox"/> > 4.0 meters (> 13') [30 pts]	<input type="checkbox"/> > 1.0 m - 1.5 m (> 3' 3" - 4' 8") [15 pts]
<input type="checkbox"/> > 3.0 m - 4.0 m (> 9' 7" - 13') [25 pts]	<input type="checkbox"/> ≤ 1.0 m (≤ 3' 3") [5 pts]
<input type="checkbox"/> > 1.5 m - 3.0 m (> 9' 7" - 4' 8") [20 pts]	

COMMENTS \_\_\_\_\_ AVERAGE BANKFULL WIDTH (meters):

Bankfull Width Max=30

**This information must also be completed**

**RIPARIAN ZONE AND FLOODPLAIN QUALITY** ☆NOTE: River Left (L) and Right (R) as looking downstream ☆

RIPARIAN WIDTH

L	R	(Per Bank)
<input type="checkbox"/>	<input type="checkbox"/>	Wide >10m
<input type="checkbox"/>	<input type="checkbox"/>	Moderate 5-10m
<input type="checkbox"/>	<input type="checkbox"/>	Narrow <5m
<input type="checkbox"/>	<input type="checkbox"/>	None

COMMENTS \_\_\_\_\_

FLOODPLAIN QUALITY

L	R	(Most Predominant per Bank)
<input type="checkbox"/>	<input type="checkbox"/>	Mature Forest, Wetland
<input type="checkbox"/>	<input type="checkbox"/>	Immature Forest, Shrub or Old Field
<input type="checkbox"/>	<input type="checkbox"/>	Residential, Park, New Field
<input type="checkbox"/>	<input type="checkbox"/>	Fenced Pasture

L	R	
<input type="checkbox"/>	<input type="checkbox"/>	Conservation Tillage
<input type="checkbox"/>	<input type="checkbox"/>	Urban or Industrial
<input type="checkbox"/>	<input type="checkbox"/>	Open Pasture, Row Crop
<input type="checkbox"/>	<input type="checkbox"/>	Mining or Construction

**FLOW REGIME (At Time of Evaluation) (Check ONLY one box):**

<input type="checkbox"/> Stream Flowing	<input type="checkbox"/> Moist Channel, isolated pools, no flow (Intermittent)
<input type="checkbox"/> Subsurface flow with isolated pools (Interstitial)	<input type="checkbox"/> Dry channel, no water (Ephemeral)

COMMENTS \_\_\_\_\_

**SINUOSITY (Number of bends per 61 m (200 ft) of channel) (Check ONLY one box):**

<input type="checkbox"/> None	<input type="checkbox"/> 1.0	<input type="checkbox"/> 2.0	<input type="checkbox"/> 3.0
<input type="checkbox"/> 0.5	<input type="checkbox"/> 1.5	<input type="checkbox"/> 2.5	<input type="checkbox"/> >3

**STREAM GRADIENT ESTIMATE**

Flat (0.5 ft/100 ft)  Flat to Moderate  Moderate (2 ft/100 ft)  Moderate to Severe  Severe (10 ft/100 ft)



**ADDITIONAL STREAM INFORMATION (This Information Must Also be Completed):**

**QHEI PERFORMED?** -  Yes  No QHEI Score \_\_\_\_\_ (If Yes, Attach Completed QHEI Form)

**DOWNSTREAM DESIGNATED USE(S)**

- WWH Name: \_\_\_\_\_ Distance from Evaluated Stream \_\_\_\_\_
- CWH Name: \_\_\_\_\_ Distance from Evaluated Stream \_\_\_\_\_
- EWH Name: \_\_\_\_\_ Distance from Evaluated Stream \_\_\_\_\_

**MAPPING: ATTACH COPIES OF MAPS, INCLUDING THE ENTIRE WATERSHED AREA. CLEARLY MARK THE SITE LOCATION**

USGS Quadrangle Name: \_\_\_\_\_ NRCS Soil Map Page: \_\_\_\_\_ NRCS Soil Map Stream Order \_\_\_\_\_

County: \_\_\_\_\_ Township / City: \_\_\_\_\_

**MISCELLANEOUS**

Base Flow Conditions? (Y/N): \_\_\_\_\_ Date of last precipitation: \_\_\_\_\_ Quantity: \_\_\_\_\_

Photograph Information: \_\_\_\_\_

Elevated Turbidity? (Y/N): \_\_\_\_\_ Canopy (% open): \_\_\_\_\_

Were samples collected for water chemistry? (Y/N): \_\_\_\_\_ (Note lab sample no. or id. and attach results) Lab Number: \_\_\_\_\_

Field Measures: Temp (°C) \_\_\_\_\_ Dissolved Oxygen (mg/l) \_\_\_\_\_ pH (S.U.) \_\_\_\_\_ Conductivity (µmhos/cm) \_\_\_\_\_

Is the sampling reach representative of the stream (Y/N) \_\_\_\_\_ If not, please explain: \_\_\_\_\_

Additional comments/description of pollution impacts: \_\_\_\_\_

**BIOTIC EVALUATION**

Performed? (Y/N): \_\_\_\_\_ (If Yes, Record all observations. Voucher collections optional. NOTE: all voucher samples must be labeled with the site ID number. Include appropriate field data sheets from the Primary Headwater Habitat Assessment Manual)

Fish Observed? (Y/N) \_\_\_\_\_ Voucher? (Y/N) \_\_\_\_\_ Salamanders Observed? (Y/N) \_\_\_\_\_ Voucher? (Y/N) \_\_\_\_\_  
Frogs or Tadpoles Observed? (Y/N) \_\_\_\_\_ Voucher? (Y/N) \_\_\_\_\_ Aquatic Macroinvertebrates Observed? (Y/N) \_\_\_\_\_ Voucher? (Y/N) \_\_\_\_\_

Comments Regarding Biology: \_\_\_\_\_

**DRAWING AND NARRATIVE DESCRIPTION OF STREAM REACH (This must be completed):**

Include important landmarks and other features of interest for site evaluation and a narrative description of the stream's location

FLOW 



# Primary Headwater Habitat Evaluation Form

HHEI Score (sum of metrics 1, 2, 3) :

SITE NAME/LOCATION \_\_\_\_\_  
 \_\_\_\_\_ SITE NUMBER \_\_\_\_\_ RIVER BASIN \_\_\_\_\_ DRAINAGE AREA (mi<sup>2</sup>) \_\_\_\_\_  
 LENGTH OF STREAM REACH (ft) \_\_\_\_\_ LAT. \_\_\_\_\_ LONG. \_\_\_\_\_ RIVER CODE \_\_\_\_\_ RIVER MILE \_\_\_\_\_  
 DATE \_\_\_\_\_ SCORER \_\_\_\_\_ COMMENTS \_\_\_\_\_

**NOTE: Complete All Items On This Form - Refer to "Field Evaluation Manual for Ohio's PWH Streams" for Instructions**

**STREAM CHANNEL MODIFICATIONS:**

NONE / NATURAL CHANNEL  RECOVERED  RECOVERING  RECENT OR NO RECOVERY

**1. SUBSTRATE (Estimate percent of every type of substrate present. Check ONLY two predominant substrate TYPE boxes (Max of 32). Add total number of significant substrate types found (Max of 8). Final metric score is sum of boxes A & B.**

TYPE	PERCENT	TYPE	PERCENT
<input type="checkbox"/> <input type="checkbox"/> BLDR SLABS [16 pts]	_____	<input type="checkbox"/> <input type="checkbox"/> SILT [3 pt]	_____
<input type="checkbox"/> <input type="checkbox"/> BOULDER (>256 mm) [16 pts]	_____	<input type="checkbox"/> <input type="checkbox"/> LEAF PACK/WOODY DEBRIS [3 pts]	_____
<input type="checkbox"/> <input type="checkbox"/> BEDROCK [16 pt]	_____	<input type="checkbox"/> <input type="checkbox"/> FINE DETRITUS [3 pts]	_____
<input type="checkbox"/> <input type="checkbox"/> COBBLE (65-256 mm) [12 pts]	_____	<input type="checkbox"/> <input type="checkbox"/> CLAY or HARDPAN [0 pt]	_____
<input type="checkbox"/> <input type="checkbox"/> GRAVEL (2-64 mm) [9 pts]	_____	<input type="checkbox"/> <input type="checkbox"/> MUCK [0 pts]	_____
<input type="checkbox"/> <input type="checkbox"/> SAND (<2 mm) [6 pts]	_____	<input type="checkbox"/> <input type="checkbox"/> ARTIFICIAL [3 pts]	_____

Total of Percentages of Bldr Slabs, Boulder, Cobble, Bedrock \_\_\_\_\_

(A)

Substrate Percentage Check

(B)

SCORE OF TWO MOST PREDOMINATE SUBSTRATE TYPES: \_\_\_\_\_

TOTAL NUMBER OF SUBSTRATE TYPES: \_\_\_\_\_

### HHEI Metric Points

Substrate Max = 40

A + B

**2. Maximum Pool Depth (Measure the maximum pool depth within the 61 meter (200 ft) evaluation reach at the time of evaluation. Avoid plunge pools from road culverts or storm water pipes) (Check ONLY one box):**

<input type="checkbox"/> > 30 centimeters [20 pts]	<input type="checkbox"/> > 5 cm - 10 cm [15 pts]
<input type="checkbox"/> > 22.5 - 30 cm [30 pts]	<input type="checkbox"/> < 5 cm [5 pts]
<input type="checkbox"/> > 10 - 22.5 cm [25 pts]	<input type="checkbox"/> NO WATER OR MOIST CHANNEL [0 pts]

COMMENTS \_\_\_\_\_ MAXIMUM POOL DEPTH (centimeters): \_\_\_\_\_

Pool Depth Max = 30

**3. BANK FULL WIDTH (Measured as the average of 3-4 measurements) (Check ONLY one box):**

<input type="checkbox"/> > 4.0 meters (> 13') [30 pts]	<input type="checkbox"/> > 1.0 m - 1.5 m (> 3' 3" - 4' 8") [15 pts]
<input type="checkbox"/> > 3.0 m - 4.0 m (> 9' 7" - 13') [25 pts]	<input type="checkbox"/> ≤ 1.0 m (≤ 3' 3") [5 pts]
<input type="checkbox"/> > 1.5 m - 3.0 m (> 9' 7" - 4' 8") [20 pts]	

COMMENTS \_\_\_\_\_ AVERAGE BANKFULL WIDTH (meters): \_\_\_\_\_

Bankfull Width Max=30

**This information must also be completed**

**RIPARIAN ZONE AND FLOODPLAIN QUALITY** ☆NOTE: River Left (L) and Right (R) as looking downstream ☆

RIPARIAN WIDTH

L	R	(Per Bank)
<input type="checkbox"/>	<input type="checkbox"/>	Wide >10m
<input type="checkbox"/>	<input type="checkbox"/>	Moderate 5-10m
<input type="checkbox"/>	<input type="checkbox"/>	Narrow <5m
<input type="checkbox"/>	<input type="checkbox"/>	None

COMMENTS \_\_\_\_\_

FLOODPLAIN QUALITY

L	R	(Most Predominant per Bank)
<input type="checkbox"/>	<input type="checkbox"/>	Mature Forest, Wetland
<input type="checkbox"/>	<input type="checkbox"/>	Immature Forest, Shrub or Old Field
<input type="checkbox"/>	<input type="checkbox"/>	Residential, Park, New Field
<input type="checkbox"/>	<input type="checkbox"/>	Fenced Pasture

L	R	
<input type="checkbox"/>	<input type="checkbox"/>	Conservation Tillage
<input type="checkbox"/>	<input type="checkbox"/>	Urban or Industrial
<input type="checkbox"/>	<input type="checkbox"/>	Open Pasture, Row Crop
<input type="checkbox"/>	<input type="checkbox"/>	Mining or Construction

**FLOW REGIME (At Time of Evaluation) (Check ONLY one box):**

<input type="checkbox"/> Stream Flowing	<input type="checkbox"/> Moist Channel, isolated pools, no flow (Intermittent)
<input type="checkbox"/> Subsurface flow with isolated pools (Interstitial)	<input type="checkbox"/> Dry channel, no water (Ephemeral)

COMMENTS \_\_\_\_\_

**SINUOSITY (Number of bends per 61 m (200 ft) of channel) (Check ONLY one box):**

<input type="checkbox"/> None	<input type="checkbox"/> 1.0	<input type="checkbox"/> 2.0	<input type="checkbox"/> 3.0
<input type="checkbox"/> 0.5	<input type="checkbox"/> 1.5	<input type="checkbox"/> 2.5	<input type="checkbox"/> >3

**STREAM GRADIENT ESTIMATE**

Flat (0.5 ft/100 ft)  Flat to Moderate  Moderate (2 ft/100 ft)  Moderate to Severe  Severe (10 ft/100 ft)

**ADDITIONAL STREAM INFORMATION (This Information Must Also be Completed):**

**QHEI PERFORMED?** -  Yes  No QHEI Score \_\_\_\_\_ (If Yes, Attach Completed QHEI Form)

**DOWNSTREAM DESIGNATED USE(S)**

- WWH Name: \_\_\_\_\_ Distance from Evaluated Stream \_\_\_\_\_
- CWH Name: \_\_\_\_\_ Distance from Evaluated Stream \_\_\_\_\_
- EWH Name: \_\_\_\_\_ Distance from Evaluated Stream \_\_\_\_\_

**MAPPING: ATTACH COPIES OF MAPS, INCLUDING THE ENTIRE WATERSHED AREA. CLEARLY MARK THE SITE LOCATION**

USGS Quadrangle Name: \_\_\_\_\_ NRCS Soil Map Page: \_\_\_\_\_ NRCS Soil Map Stream Order \_\_\_\_\_

County: \_\_\_\_\_ Township / City: \_\_\_\_\_

**MISCELLANEOUS**

Base Flow Conditions? (Y/N): \_\_\_\_\_ Date of last precipitation: \_\_\_\_\_ Quantity: \_\_\_\_\_

Photograph Information: \_\_\_\_\_

Elevated Turbidity? (Y/N): \_\_\_\_\_ Canopy (% open): \_\_\_\_\_

Were samples collected for water chemistry? (Y/N): \_\_\_\_\_ (Note lab sample no. or id. and attach results) Lab Number: \_\_\_\_\_

Field Measures: Temp (°C) \_\_\_\_\_ Dissolved Oxygen (mg/l) \_\_\_\_\_ pH (S.U.) \_\_\_\_\_ Conductivity (µmhos/cm) \_\_\_\_\_

Is the sampling reach representative of the stream (Y/N) \_\_\_\_\_ If not, please explain: \_\_\_\_\_

Additional comments/description of pollution impacts: \_\_\_\_\_

**BIOTIC EVALUATION**

Performed? (Y/N): \_\_\_\_\_ (If Yes, Record all observations. Voucher collections optional. NOTE: all voucher samples must be labeled with the site ID number. Include appropriate field data sheets from the Primary Headwater Habitat Assessment Manual)

Fish Observed? (Y/N) \_\_\_\_\_ Voucher? (Y/N) \_\_\_\_\_ Salamanders Observed? (Y/N) \_\_\_\_\_ Voucher? (Y/N) \_\_\_\_\_  
Frogs or Tadpoles Observed? (Y/N) \_\_\_\_\_ Voucher? (Y/N) \_\_\_\_\_ Aquatic Macroinvertebrates Observed? (Y/N) \_\_\_\_\_ Voucher? (Y/N) \_\_\_\_\_

Comments Regarding Biology: \_\_\_\_\_

**DRAWING AND NARRATIVE DESCRIPTION OF STREAM REACH (This must be completed):**

Include important landmarks and other features of interest for site evaluation and a narrative description of the stream's location

FLOW 

**PHWH STREAM BIOLOGICAL CHARACTERISTICS FIELD SHEET:**

**1. Fish:**                      Voucher Specimens Retained? (select)                      Time Spent (minutes): \_\_\_\_\_  
 Sample Method \_\_\_\_\_                      Stream Length Assessed (meters) \_\_\_\_\_

Species	Number Caught	Notes

**2. Salamanders:**                      Voucher Specimens Retained? (circle) Y / N                      Time Spent (minutes): \_\_\_\_\_  
 Sample Method \_\_\_\_\_                      Stream Length Assessed (meters) \_\_\_\_\_

Species ( <i>Genus</i> )	# Larvae	# Juveniles/Adults	Total Number
<b>Mountain Dusky</b> ( <i>Desmognathus ochrophaeus</i> )			
<b>Northern Dusky</b> ( <i>Desmognathus fuscus</i> )			
<b>Two-lined</b> ( <i>Eurycea bislineata</i> )			
<b>Long-tailed</b> ( <i>Eurycea longicauda</i> )			
<b>Cave</b> ( <i>Eurycea lucifuga</i> )			
<b>Red</b> ( <i>Pseudotriton ruber</i> )			
<b>Mud</b> ( <i>Pseudotriton montanus</i> )			
<b>Spring</b> ( <i>Gyrinophilus porphyriticus</i> )			
<b>Mole spp.</b> ( <i>Ambystoma spp.</i> )			
<b>Four-toed</b> ( <i>Hemidactylium scutatum</i> )			
<b>Other (name)</b>			
<b>Total</b>			

Notes on Vertebrates: \_\_\_\_\_

### 3. Macroinvertebrate Scoring Sheet:

#### THE HEADWATER MACROINVERTEBRATE FIELD EVALUATION INDEX (HMFEI) SCORING SHEET

Indicate Abundance of Each Taxa Above each White Box.

Record HMFEI Scoring Value Points Within each Box.

For EPT taxa, also indicate the different taxa present.

**Key:** **V** = Very Abundant (> 50); **A** = Abundant (10 -50); **C** = Common (3 -9); **R** = Rare (< 3)

Sessile Animals ( <b>Porifera</b> , <b>Cnidaria</b> , <b>Bryozoa</b> ) (HMFEI pts = 1)	<input type="text"/>	Crayfish ( <b>Decapoda</b> ) (HMFEI pts = 2)	<input type="text"/>	Fishfly Larvae ( <b>Corydalidae</b> ) (HMFEI pts = 3)	<input type="text"/>
Aquatic Worms ( <b>Turbellaria</b> , <b>Hirudinea</b> , <b>Oligochaeta</b> ) (HMFEI pts = 1)	<input type="text"/>	Dragonfly Nymphs ( <b>Anisoptera</b> ) (HMFEI pts = 2)	<input type="text"/>	Water Penny Beetles ( <b>Psephenidae</b> ) (HMFEI pts = 3)	<input type="text"/>
Sow Bugs ( <b>Isopoda</b> ) (HMFEI pts = 1)	<input type="text"/>	Riffle Beetles ( <b>Dryopidae</b> , <b>Elmidae</b> , <b>Ptilodactylidae</b> ) (HMFEI pts = 2)	<input type="text"/>	Crane-fly Larvae ( <b>Tipulidae</b> ) (HMFEI pts = 3)	<input type="text"/>
Scuds ( <b>Amphipoda</b> ) (HMFEI pts = 1)	<input type="text"/>	Larvae of other Flies (enter name in comments) ( <b>Diptera</b> ): (HMFEI pts = 1)	<input type="text"/>	<b>EPT TAXA*</b>	
Water Mites ( <b>Hydracarina</b> ) (HMFEI pts = 1)	<input type="text"/>	Midges ( <b>Chironomidae</b> ) (HMFEI pts = 1)	<input type="text"/>	Total No. EPT Taxa = _____	
Damselfly Nymphs ( <b>Zygoptera</b> ) (HMFEI pts = 1)	<input type="text"/>	Snails ( <b>Gastropoda</b> ) (HMFEI pts = 1)	<input type="text"/>	Mayfly Nymphs ( <b>Ephemeroptera</b> ) Taxa Present: HMFEI pts = _____	<input type="text"/>
Alderfly Larvae ( <b>Sialidae</b> ) (HMFEI pts = 1)	<input type="text"/>	Clams ( <b>Bivalvia</b> ) (HMFEI pts = 1)	<input type="text"/>	No. Taxa (x) 3] _____	
Other Beetles ( <b>Coleoptera</b> ) (HMFEI pts = 1)	<input type="text"/>	Other Taxa :		Stonefly Nymphs ( <b>Plecoptera</b> ) Taxa Present: HMFEI pts = _____	<input type="text"/>
Other Taxa:		Other Taxa:		No. Taxa (x) 3] _____	
Other Taxa:		Other Taxa:		Caddisfly Larvae ( <b>Trichoptera</b> ) Taxa Present: HMFEI pts = _____	<input type="text"/>
Other Taxa:		Other Taxa:		No. Taxa (x) 3] _____	

\*Note: EPT identification based upon Family or Genus level of taxonomy

Voucher Sample ID \_\_\_\_\_

Time Spent (minutes): \_\_\_\_\_

Notes on Macroinvertebrates: (Predominant Organisms; Other Common Organisms; Diversity Estimate)

---



---



---

Final HMFEI Calculated Score (Sum of All White Box Scores) =

IF Final HMFEI Score is > 19, Then CLASS III PHWH STREAM  
 IF Final HMFEI Score is 7 to 19, Then CLASS II PHWH STREAM  
 IF Final HMFEI Score is < 7, Then CLASS I PHWH STREAM

**PHWH STREAM BIOLOGICAL CHARACTERISTICS FIELD SHEET:**

**1. Fish:**                      Voucher Specimens Retained? (select)                      Time Spent (minutes): \_\_\_\_\_  
 Sample Method \_\_\_\_\_                      Stream Length Assessed (meters) \_\_\_\_\_

Species	Number Caught	Notes

**2. Salamanders:**                      Voucher Specimens Retained? (circle) Y / N                      Time Spent (minutes): \_\_\_\_\_  
 Sample Method \_\_\_\_\_                      Stream Length Assessed (meters) \_\_\_\_\_

Species ( <i>Genus</i> )	# Larvae	# Juveniles/Adults	Total Number
<b>Mountain Dusky</b> ( <i>Desmognathus ochrophaeus</i> )			
<b>Northern Dusky</b> ( <i>Desmognathus fuscus</i> )			
<b>Two-lined</b> ( <i>Eurycea bislineata</i> )			
<b>Long-tailed</b> ( <i>Eurycea longicauda</i> )			
<b>Cave</b> ( <i>Eurycea lucifuga</i> )			
<b>Red</b> ( <i>Pseudotriton ruber</i> )			
<b>Mud</b> ( <i>Pseudotriton montanus</i> )			
<b>Spring</b> ( <i>Gyrinophilus porphyriticus</i> )			
<b>Mole spp.</b> ( <i>Ambystoma spp.</i> )			
<b>Four-toed</b> ( <i>Hemidactylium scutatum</i> )			
<b>Other (name)</b>			
<b>Total</b>			

Notes on Vertebrates: \_\_\_\_\_

### 3. Macroinvertebrate Scoring Sheet:

#### THE HEADWATER MACROINVERTEBRATE FIELD EVALUATION INDEX (HMFEI) SCORING SHEET

Indicate Abundance of Each Taxa Above each White Box.

Record HMFEI Scoring Value Points Within each Box.

For EPT taxa, also indicate the different taxa present.

**Key:** **V** = Very Abundant (> 50); **A** = Abundant (10 -50); **C** = Common (3 -9); **R** = Rare (< 3)

Sessile Animals ( <b>Porifera</b> , <b>Cnidaria</b> , <b>Bryozoa</b> ) (HMFEI pts = 1)	<input type="text"/>	Crayfish ( <b>Decapoda</b> ) (HMFEI pts = 2)	<input type="text"/>	Fishfly Larvae ( <b>Corydalidae</b> ) (HMFEI pts = 3)	<input type="text"/>
Aquatic Worms ( <b>Turbellaria</b> , <b>Hirudinea</b> , <b>Oligochaeta</b> ) (HMFEI pts = 1)	<input type="text"/>	Dragonfly Nymphs ( <b>Anisoptera</b> ) (HMFEI pts = 2)	<input type="text"/>	Water Penny Beetles ( <b>Psephenidae</b> ) (HMFEI pts = 3)	<input type="text"/>
Sow Bugs ( <b>Isopoda</b> ) (HMFEI pts = 1)	<input type="text"/>	Riffle Beetles ( <b>Dryopidae</b> , <b>Elmidae</b> , <b>Ptilodactylidae</b> ) (HMFEI pts = 2)	<input type="text"/>	Crane-fly Larvae ( <b>Tipulidae</b> ) (HMFEI pts = 3)	<input type="text"/>
Scuds ( <b>Amphipoda</b> ) (HMFEI pts = 1)	<input type="text"/>	Larvae of other Flies (enter name in comments) ( <b>Diptera</b> ): (HMFEI pts = 1)	<input type="text"/>	<b>EPT TAXA*</b>	
Water Mites ( <b>Hydracarina</b> ) (HMFEI pts = 1)	<input type="text"/>	Midges ( <b>Chironomidae</b> ) (HMFEI pts = 1)	<input type="text"/>	Total No. EPT Taxa = _____	
Damselfly Nymphs ( <b>Zygoptera</b> ) (HMFEI pts = 1)	<input type="text"/>	Snails ( <b>Gastropoda</b> ) (HMFEI pts = 1)	<input type="text"/>	Mayfly Nymphs ( <b>Ephemeroptera</b> ) Taxa Present: HMFEI pts = _____	<input type="text"/>
Alderfly Larvae ( <b>Sialidae</b> ) (HMFEI pts = 1)	<input type="text"/>	Clams ( <b>Bivalvia</b> ) (HMFEI pts = 1)	<input type="text"/>	No. Taxa (x) 3] _____	
Other Beetles ( <b>Coleoptera</b> ) (HMFEI pts = 1)	<input type="text"/>	Other Taxa :		Stonefly Nymphs ( <b>Plecoptera</b> ) Taxa Present: HMFEI pts = _____	<input type="text"/>
Other Taxa:		Other Taxa:		No. Taxa (x) 3] _____	
Other Taxa:		Other Taxa:		Caddisfly Larvae ( <b>Trichoptera</b> ) Taxa Present: HMFEI pts = _____	<input type="text"/>
Other Taxa:		Other Taxa:		No. Taxa (x) 3] _____	

\*Note: EPT identification based upon Family or Genus level of taxonomy

Voucher Sample ID \_\_\_\_\_

Time Spent (minutes): \_\_\_\_\_

Notes on Macroinvertebrates: (Predominant Organisms; Other Common Organisms; Diversity Estimate)

---



---



---

Final HMFEI Calculated Score (Sum of All White Box Scores) =

IF Final HMFEI Score is > 19, Then CLASS III PHWH STREAM  
 IF Final HMFEI Score is 7 to 19, Then CLASS II PHWH STREAM  
 IF Final HMFEI Score is < 7, Then CLASS I PHWH STREAM

## PHWH STREAM BIOLOGICAL CHARACTERISTICS FIELD SHEET:

**1. Fish:**                      Voucher Specimens Retained? (select)                      Time Spent (minutes): \_\_\_\_\_  
    Sample Method \_\_\_\_\_                      Stream Length Assessed (meters) \_\_\_\_\_

Species	Number Caught	Notes

**2. Salamanders:**                      Voucher Specimens Retained? (circle) Y / N                      Time Spent (minutes): \_\_\_\_\_  
    Sample Method \_\_\_\_\_                      Stream Length Assessed (meters) \_\_\_\_\_

Species ( <i>Genus</i> )	# Larvae	# Juveniles/Adults	Total Number
<b>Mountain Dusky</b> ( <i>Desmognathus ochrophaeus</i> )			
<b>Northern Dusky</b> ( <i>Desmognathus fuscus</i> )			
<b>Two-lined</b> ( <i>Eurycea bislineata</i> )			
<b>Long-tailed</b> ( <i>Eurycea longicauda</i> )			
<b>Cave</b> ( <i>Eurycea lucifuga</i> )			
<b>Red</b> ( <i>Pseudotriton ruber</i> )			
<b>Mud</b> ( <i>Pseudotriton montanus</i> )			
<b>Spring</b> ( <i>Gyrinophilus porphyriticus</i> )			
<b>Mole spp.</b> ( <i>Ambystoma spp.</i> )			
<b>Four-toed</b> ( <i>Hemidactylium scutatum</i> )			
<b>Other (name)</b>			
<b>Total</b>			

**Notes on Vertebrates:** \_\_\_\_\_



### 3. Macroinvertebrate Scoring Sheet:

#### THE HEADWATER MACROINVERTEBRATE FIELD EVALUATION INDEX (HMFEI) SCORING SHEET

Indicate Abundance of Each Taxa Above each White Box.

Record HMFEI Scoring Value Points Within each Box.

For EPT taxa, also indicate the different taxa present.

**Key:** **V** = Very Abundant (> 50); **A** = Abundant (10 -50); **C** = Common (3 -9); **R** = Rare (< 3)

Sessile Animals ( <b>Porifera</b> , <b>Cnidaria</b> , <b>Bryozoa</b> ) (HMFEI pts = 1)	<input type="text"/>	Crayfish ( <b>Decapoda</b> ) (HMFEI pts = 2)	<input type="text"/>	Fishfly Larvae ( <b>Corydalidae</b> ) (HMFEI pts = 3)	<input type="text"/>
Aquatic Worms ( <b>Turbellaria</b> , <b>Hirudinea</b> , <b>Oligochaeta</b> ) (HMFEI pts = 1)	<input type="text"/>	Dragonfly Nymphs ( <b>Anisoptera</b> ) (HMFEI pts = 2)	<input type="text"/>	Water Penny Beetles ( <b>Psephenidae</b> ) (HMFEI pts = 3)	<input type="text"/>
Sow Bugs ( <b>Isopoda</b> ) (HMFEI pts = 1)	<input type="text"/>	Riffle Beetles ( <b>Dryopidae</b> , <b>Elmidae</b> , <b>Ptilodactylidae</b> ) (HMFEI pts = 2)	<input type="text"/>	Crane-fly Larvae ( <b>Tipulidae</b> ) (HMFEI pts = 3)	<input type="text"/>
Scuds ( <b>Amphipoda</b> ) (HMFEI pts = 1)	<input type="text"/>	Larvae of other Flies (enter name in comments) ( <b>Diptera</b> ): (HMFEI pts = 1)	<input type="text"/>	<b>EPT TAXA*</b>	
Water Mites ( <b>Hydracarina</b> ) (HMFEI pts = 1)	<input type="text"/>	Midges ( <b>Chironomidae</b> ) (HMFEI pts = 1)	<input type="text"/>	Total No. EPT Taxa = _____	
Damselfly Nymphs ( <b>Zygoptera</b> ) (HMFEI pts = 1)	<input type="text"/>	Snails ( <b>Gastropoda</b> ) (HMFEI pts = 1)	<input type="text"/>	Mayfly Nymphs ( <b>Ephemeroptera</b> ) Taxa Present: HMFEI pts = _____	<input type="text"/>
Alderfly Larvae ( <b>Sialidae</b> ) (HMFEI pts = 1)	<input type="text"/>	Clams ( <b>Bivalvia</b> ) (HMFEI pts = 1)	<input type="text"/>	No. Taxa (x) 3] _____	
Other Beetles ( <b>Coleoptera</b> ) (HMFEI pts = 1)	<input type="text"/>	Other Taxa :		Stonefly Nymphs ( <b>Plecoptera</b> ) Taxa Present: HMFEI pts = _____	<input type="text"/>
Other Taxa:		Other Taxa:		No. Taxa (x) 3] _____	
Other Taxa:		Other Taxa:		Caddisfly Larvae ( <b>Trichoptera</b> ) Taxa Present: HMFEI pts = _____	<input type="text"/>
Other Taxa:		Other Taxa:		No. Taxa (x) 3] _____	

\*Note: EPT identification based upon Family or Genus level of taxonomy

Voucher Sample ID \_\_\_\_\_

Time Spent (minutes): \_\_\_\_\_

Notes on Macroinvertebrates: (Predominant Organisms; Other Common Organisms; Diversity Estimate)

---



---



---

Final HMFEI Calculated Score (Sum of All White Box Scores) =

IF Final HMFEI Score is > 19, Then CLASS III PWH STREAM  
 IF Final HMFEI Score is 7 to 19, Then CLASS II PWH STREAM  
 IF Final HMFEI Score is < 7, Then CLASS I PWH STREAM

## PHWH STREAM BIOLOGICAL CHARACTERISTICS FIELD SHEET:

**1. Fish:**                      Voucher Specimens Retained? (select)                      Time Spent (minutes): \_\_\_\_\_  
    Sample Method \_\_\_\_\_                      Stream Length Assessed (meters) \_\_\_\_\_

Species	Number Caught	Notes

**2. Salamanders:**                      Voucher Specimens Retained? (circle) Y / N                      Time Spent (minutes): \_\_\_\_\_  
    Sample Method \_\_\_\_\_                      Stream Length Assessed (meters) \_\_\_\_\_

Species ( <i>Genus</i> )	# Larvae	# Juveniles/Adults	Total Number
<b>Mountain Dusky</b> ( <i>Desmognathus ochrophaeus</i> )			
<b>Northern Dusky</b> ( <i>Desmognathus fuscus</i> )			
<b>Two-lined</b> ( <i>Eurycea bislineata</i> )			
<b>Long-tailed</b> ( <i>Eurycea longicauda</i> )			
<b>Cave</b> ( <i>Eurycea lucifuga</i> )			
<b>Red</b> ( <i>Pseudotriton ruber</i> )			
<b>Mud</b> ( <i>Pseudotriton montanus</i> )			
<b>Spring</b> ( <i>Gyrinophilus porphyriticus</i> )			
<b>Mole spp.</b> ( <i>Ambystoma spp.</i> )			
<b>Four-toed</b> ( <i>Hemidactylium scutatum</i> )			
<b>Other (name)</b>			
<b>Total</b>			

**Notes on Vertebrates:** \_\_\_\_\_

### 3. Macroinvertebrate Scoring Sheet:

#### THE HEADWATER MACROINVERTEBRATE FIELD EVALUATION INDEX (HMFEI) SCORING SHEET

Indicate Abundance of Each Taxa Above each White Box.

Record HMFEI Scoring Value Points Within each Box.

For EPT taxa, also indicate the different taxa present.

**Key:** **V** = Very Abundant (> 50); **A** = Abundant (10 -50); **C** = Common (3 -9); **R** = Rare (< 3)

Sessile Animals ( <b>Porifera</b> , <b>Cnidaria</b> , <b>Bryozoa</b> ) (HMFEI pts = 1)	<input type="text"/>	Crayfish ( <b>Decapoda</b> ) (HMFEI pts = 2)	<input type="text"/>	Fishfly Larvae ( <b>Corydalidae</b> ) (HMFEI pts = 3)	<input type="text"/>
Aquatic Worms ( <b>Turbellaria</b> , <b>Hirudinea</b> , <b>Oligochaeta</b> ) (HMFEI pts = 1)	<input type="text"/>	Dragonfly Nymphs ( <b>Anisoptera</b> ) (HMFEI pts = 2)	<input type="text"/>	Water Penny Beetles ( <b>Psephenidae</b> ) (HMFEI pts = 3)	<input type="text"/>
Sow Bugs ( <b>Isopoda</b> ) (HMFEI pts = 1)	<input type="text"/>	Riffle Beetles ( <b>Dryopidae</b> , <b>Elmidae</b> , <b>Ptilodactylidae</b> ) (HMFEI pts = 2)	<input type="text"/>	Crane-fly Larvae ( <b>Tipulidae</b> ) (HMFEI pts = 3)	<input type="text"/>
Scuds ( <b>Amphipoda</b> ) (HMFEI pts = 1)	<input type="text"/>	Larvae of other Flies (enter name in comments) ( <b>Diptera</b> ): (HMFEI pts = 1)	<input type="text"/>	<b>EPT TAXA*</b>	
Water Mites ( <b>Hydracarina</b> ) (HMFEI pts = 1)	<input type="text"/>	Midges ( <b>Chironomidae</b> ) (HMFEI pts = 1)	<input type="text"/>	Total No. EPT Taxa = _____	
Damselfly Nymphs ( <b>Zygoptera</b> ) (HMFEI pts = 1)	<input type="text"/>	Snails ( <b>Gastropoda</b> ) (HMFEI pts = 1)	<input type="text"/>	Mayfly Nymphs ( <b>Ephemeroptera</b> ) Taxa Present: HMFEI pts = _____	<input type="text"/>
Alderfly Larvae ( <b>Sialidae</b> ) (HMFEI pts = 1)	<input type="text"/>	Clams ( <b>Bivalvia</b> ) (HMFEI pts = 1)	<input type="text"/>	No. Taxa (x) 3] _____	
Other Beetles ( <b>Coleoptera</b> ) (HMFEI pts = 1)	<input type="text"/>	Other Taxa :		Stonefly Nymphs ( <b>Plecoptera</b> ) Taxa Present: HMFEI pts = _____	<input type="text"/>
Other Taxa:		Other Taxa:		No. Taxa (x) 3] _____	
Other Taxa:		Other Taxa:		Caddisfly Larvae ( <b>Trichoptera</b> ) Taxa Present: HMFEI pts = _____	<input type="text"/>
Other Taxa:		Other Taxa:		No. Taxa (x) 3] _____	

\*Note: EPT identification based upon Family or Genus level of taxonomy

Voucher Sample ID \_\_\_\_\_

Time Spent (minutes): \_\_\_\_\_

Notes on Macroinvertebrates: (Predominant Organisms; Other Common Organisms; Diversity Estimate)

---



---



---

Final HMFEI Calculated Score (Sum of All White Box Scores) =

IF Final HMFEI Score is > 19, Then CLASS III PHWH STREAM  
 IF Final HMFEI Score is 7 to 19, Then CLASS II PHWH STREAM  
 IF Final HMFEI Score is < 7, Then CLASS I PHWH STREAM

**PHWH STREAM BIOLOGICAL CHARACTERISTICS FIELD SHEET:**

**1. Fish:**                      Voucher Specimens Retained? (select)                      Time Spent (minutes): \_\_\_\_\_  
 Sample Method \_\_\_\_\_                      Stream Length Assessed (meters) \_\_\_\_\_

Species	Number Caught	Notes

**2. Salamanders:**                      Voucher Specimens Retained? (circle) Y / N                      Time Spent (minutes): \_\_\_\_\_  
 Sample Method \_\_\_\_\_                      Stream Length Assessed (meters) \_\_\_\_\_

Species ( <i>Genus</i> )	# Larvae	# Juveniles/Adults	Total Number
<b>Mountain Dusky</b> ( <i>Desmognathus ochrophaeus</i> )			
<b>Northern Dusky</b> ( <i>Desmognathus fuscus</i> )			
<b>Two-lined</b> ( <i>Eurycea bislineata</i> )			
<b>Long-tailed</b> ( <i>Eurycea longicauda</i> )			
<b>Cave</b> ( <i>Eurycea lucifuga</i> )			
<b>Red</b> ( <i>Pseudotriton ruber</i> )			
<b>Mud</b> ( <i>Pseudotriton montanus</i> )			
<b>Spring</b> ( <i>Gyrinophilus porphyriticus</i> )			
<b>Mole spp.</b> ( <i>Ambystoma spp.</i> )			
<b>Four-toed</b> ( <i>Hemidactylium scutatum</i> )			
<b>Other (name)</b>			
<b>Total</b>			

Notes on Vertebrates: \_\_\_\_\_

### 3. Macroinvertebrate Scoring Sheet:

#### THE HEADWATER MACROINVERTEBRATE FIELD EVALUATION INDEX (HMFEI) SCORING SHEET

Indicate Abundance of Each Taxa Above each White Box.

Record HMFEI Scoring Value Points Within each Box.

For EPT taxa, also indicate the different taxa present.

**Key:** **V** = Very Abundant (> 50); **A** = Abundant (10 -50); **C** = Common (3 -9); **R** = Rare (< 3)

Sessile Animals ( <b>Porifera</b> , <b>Cnidaria</b> , <b>Bryozoa</b> ) (HMFEI pts = 1)	<input type="text"/>	Crayfish ( <b>Decapoda</b> ) (HMFEI pts = 2)	<input type="text"/>	Fishfly Larvae ( <b>Corydalidae</b> ) (HMFEI pts = 3)	<input type="text"/>
Aquatic Worms ( <b>Turbellaria</b> , <b>Hirudinea</b> , <b>Oligochaeta</b> ) (HMFEI pts = 1)	<input type="text"/>	Dragonfly Nymphs ( <b>Anisoptera</b> ) (HMFEI pts = 2)	<input type="text"/>	Water Penny Beetles ( <b>Psephenidae</b> ) (HMFEI pts = 3)	<input type="text"/>
Sow Bugs ( <b>Isopoda</b> ) (HMFEI pts = 1)	<input type="text"/>	Riffle Beetles ( <b>Dryopidae</b> , <b>Elmidae</b> , <b>Ptilodactylidae</b> ) (HMFEI pts = 2)	<input type="text"/>	Crane-fly Larvae ( <b>Tipulidae</b> ) (HMFEI pts = 3)	<input type="text"/>
Scuds ( <b>Amphipoda</b> ) (HMFEI pts = 1)	<input type="text"/>	Larvae of other Flies (enter name in comments) ( <b>Diptera</b> ): (HMFEI pts = 1)	<input type="text"/>	<b>EPT TAXA*</b> Total No. EPT Taxa = _____	
Water Mites ( <b>Hydracarina</b> ) (HMFEI pts = 1)	<input type="text"/>	Midges ( <b>Chironomidae</b> ) (HMFEI pts = 1)	<input type="text"/>	Mayfly Nymphs ( <b>Ephemeroptera</b> ) Taxa Present: HMFEI pts = _____ No. Taxa (x) 3]	<input type="text"/>
Damselfly Nymphs ( <b>Zygoptera</b> ) (HMFEI pts = 1)	<input type="text"/>	Snails ( <b>Gastropoda</b> ) (HMFEI pts = 1)	<input type="text"/>		
Alderfly Larvae ( <b>Sialidae</b> ) (HMFEI pts = 1)	<input type="text"/>	Clams ( <b>Bivalvia</b> ) (HMFEI pts = 1)	<input type="text"/>	Stonefly Nymphs ( <b>Plecoptera</b> ) Taxa Present: HMFEI pts = _____ No. Taxa (x) 3]	<input type="text"/>
Other Beetles ( <b>Coleoptera</b> ) (HMFEI pts = 1)	<input type="text"/>	Other Taxa :			
Other Taxa:		Other Taxa:		Caddisfly Larvae ( <b>Trichoptera</b> ) Taxa Present: HMFEI pts = _____ No. Taxa (x) 3]	<input type="text"/>
Other Taxa:		Other Taxa			

\*Note: EPT identification based upon Family or Genus level of taxonomy

Voucher Sample ID \_\_\_\_\_

Time Spent (minutes): \_\_\_\_\_

Notes on Macroinvertebrates: (Predominant Organisms; Other Common Organisms; Diversity Estimate)

---



---



---

Final HMFEI Calculated Score (Sum of All White Box Scores) =

IF Final HMFEI Score is > 19, Then CLASS III PHWH STREAM  
 IF Final HMFEI Score is 7 to 19, Then CLASS II PHWH STREAM  
 IF Final HMFEI Score is < 7, Then CLASS I PHWH STREAM

**PHWH STREAM BIOLOGICAL CHARACTERISTICS FIELD SHEET:**

**1. Fish:**                      Voucher Specimens Retained? (select)                      Time Spent (minutes): \_\_\_\_\_  
 Sample Method \_\_\_\_\_                      Stream Length Assessed (meters) \_\_\_\_\_

Species	Number Caught	Notes

**2. Salamanders:**                      Voucher Specimens Retained? (circle) Y / N                      Time Spent (minutes): \_\_\_\_\_  
 Sample Method \_\_\_\_\_                      Stream Length Assessed (meters) \_\_\_\_\_

Species ( <i>Genus</i> )	# Larvae	# Juveniles/Adults	Total Number
<b>Mountain Dusky</b> ( <i>Desmognathus ochrophaeus</i> )			
<b>Northern Dusky</b> ( <i>Desmognathus fuscus</i> )			
<b>Two-lined</b> ( <i>Eurycea bislineata</i> )			
<b>Long-tailed</b> ( <i>Eurycea longicauda</i> )			
<b>Cave</b> ( <i>Eurycea lucifuga</i> )			
<b>Red</b> ( <i>Pseudotriton ruber</i> )			
<b>Mud</b> ( <i>Pseudotriton montanus</i> )			
<b>Spring</b> ( <i>Gyrinophilus porphyriticus</i> )			
<b>Mole spp.</b> ( <i>Ambystoma spp.</i> )			
<b>Four-toed</b> ( <i>Hemidactylium scutatum</i> )			
<b>Other (name)</b>			
<b>Total</b>			

Notes on Vertebrates: \_\_\_\_\_

### 3. Macroinvertebrate Scoring Sheet:

#### THE HEADWATER MACROINVERTEBRATE FIELD EVALUATION INDEX (HMFEI) SCORING SHEET

Indicate Abundance of Each Taxa Above each White Box.

Record HMFEI Scoring Value Points Within each Box.

For EPT taxa, also indicate the different taxa present.

**Key:** **V** = Very Abundant (> 50); **A** = Abundant (10 -50); **C** = Common (3 -9); **R** = Rare (< 3)

Sessile Animals ( <b>Porifera</b> , <b>Cnidaria</b> , <b>Bryozoa</b> ) (HMFEI pts = 1)	<input type="text"/>	Crayfish ( <b>Decapoda</b> ) (HMFEI pts = 2)	<input type="text"/>	Fishfly Larvae ( <b>Corydalidae</b> ) (HMFEI pts = 3)	<input type="text"/>
Aquatic Worms ( <b>Turbellaria</b> , <b>Hirudinea</b> , <b>Oligochaeta</b> ) (HMFEI pts = 1)	<input type="text"/>	Dragonfly Nymphs ( <b>Anisoptera</b> ) (HMFEI pts = 2)	<input type="text"/>	Water Penny Beetles ( <b>Psephenidae</b> ) (HMFEI pts = 3)	<input type="text"/>
Sow Bugs ( <b>Isopoda</b> ) (HMFEI pts = 1)	<input type="text"/>	Riffle Beetles ( <b>Dryopidae</b> , <b>Elmidae</b> , <b>Ptilodactylidae</b> ) (HMFEI pts = 2)	<input type="text"/>	Crane-fly Larvae ( <b>Tipulidae</b> ) (HMFEI pts = 3)	<input type="text"/>
Scuds ( <b>Amphipoda</b> ) (HMFEI pts = 1)	<input type="text"/>	Larvae of other Flies (enter name in comments) ( <b>Diptera</b> ): (HMFEI pts = 1)	<input type="text"/>	<b>EPT TAXA*</b>	
Water Mites ( <b>Hydracarina</b> ) (HMFEI pts = 1)	<input type="text"/>	Midges ( <b>Chironomidae</b> ) (HMFEI pts = 1)	<input type="text"/>	Total No. EPT Taxa = _____	
Damselfly Nymphs ( <b>Zygoptera</b> ) (HMFEI pts = 1)	<input type="text"/>	Snails ( <b>Gastropoda</b> ) (HMFEI pts = 1)	<input type="text"/>	Mayfly Nymphs ( <b>Ephemeroptera</b> ) Taxa Present: HMFEI pts = _____	<input type="text"/>
Alderfly Larvae ( <b>Sialidae</b> ) (HMFEI pts = 1)	<input type="text"/>	Clams ( <b>Bivalvia</b> ) (HMFEI pts = 1)	<input type="text"/>	No. Taxa (x) 3] _____	
Other Beetles ( <b>Coleoptera</b> ) (HMFEI pts = 1)	<input type="text"/>	Other Taxa :		Stonefly Nymphs ( <b>Plecoptera</b> ) Taxa Present: HMFEI pts = _____	<input type="text"/>
Other Taxa:		Other Taxa:		No. Taxa (x) 3] _____	
Other Taxa:		Other Taxa:		Caddisfly Larvae ( <b>Trichoptera</b> ) Taxa Present: HMFEI pts = _____	<input type="text"/>
Other Taxa:		Other Taxa:		No. Taxa (x) 3] _____	

\*Note: EPT identification based upon Family or Genus level of taxonomy

Voucher Sample ID \_\_\_\_\_

Time Spent (minutes): \_\_\_\_\_

Notes on Macroinvertebrates: (Predominant Organisms; Other Common Organisms; Diversity Estimate)

---



---



---

Final HMFEI Calculated Score (Sum of All White Box Scores) =

IF Final HMFEI Score is > 19, Then CLASS III PWH STREAM  
 IF Final HMFEI Score is 7 to 19, Then CLASS II PWH STREAM  
 IF Final HMFEI Score is < 7, Then CLASS I PWH STREAM

## PHWH STREAM BIOLOGICAL CHARACTERISTICS FIELD SHEET:

**1. Fish:**                      Voucher Specimens Retained? (select)                      Time Spent (minutes): \_\_\_\_\_  
    Sample Method \_\_\_\_\_                      Stream Length Assessed (meters) \_\_\_\_\_

Species	Number Caught	Notes

**2. Salamanders:**                      Voucher Specimens Retained? (circle) Y / N                      Time Spent (minutes): \_\_\_\_\_  
    Sample Method \_\_\_\_\_                      Stream Length Assessed (meters) \_\_\_\_\_

Species ( <i>Genus</i> )	# Larvae	# Juveniles/Adults	Total Number
<b>Mountain Dusky</b> ( <i>Desmognathus ochrophaeus</i> )			
<b>Northern Dusky</b> ( <i>Desmognathus fuscus</i> )			
<b>Two-lined</b> ( <i>Eurycea bislineata</i> )			
<b>Long-tailed</b> ( <i>Eurycea longicauda</i> )			
<b>Cave</b> ( <i>Eurycea lucifuga</i> )			
<b>Red</b> ( <i>Pseudotriton ruber</i> )			
<b>Mud</b> ( <i>Pseudotriton montanus</i> )			
<b>Spring</b> ( <i>Gyrinophilus porphyriticus</i> )			
<b>Mole spp.</b> ( <i>Ambystoma spp.</i> )			
<b>Four-toed</b> ( <i>Hemidactylium scutatum</i> )			
<b>Other (name)</b>			
<b>Total</b>			

**Notes on Vertebrates:** \_\_\_\_\_



### 3. Macroinvertebrate Scoring Sheet:

#### THE HEADWATER MACROINVERTEBRATE FIELD EVALUATION INDEX (HMFEI) SCORING SHEET

Indicate Abundance of Each Taxa Above each White Box.

Record HMFEI Scoring Value Points Within each Box.

For EPT taxa, also indicate the different taxa present.

**Key:** **V** = Very Abundant (> 50); **A** = Abundant (10 -50); **C** = Common (3 -9); **R** = Rare (< 3)

Sessile Animals ( <b>Porifera</b> , <b>Cnidaria</b> , <b>Bryozoa</b> ) (HMFEI pts = 1)	<input type="text"/>	Crayfish ( <b>Decapoda</b> ) (HMFEI pts = 2)	<input type="text"/>	Fishfly Larvae ( <b>Corydalidae</b> ) (HMFEI pts = 3)	<input type="text"/>
Aquatic Worms ( <b>Turbellaria</b> , <b>Hirudinea</b> , <b>Oligochaeta</b> ) (HMFEI pts = 1)	<input type="text"/>	Dragonfly Nymphs ( <b>Anisoptera</b> ) (HMFEI pts = 2)	<input type="text"/>	Water Penny Beetles ( <b>Psephenidae</b> ) (HMFEI pts = 3)	<input type="text"/>
Sow Bugs ( <b>Isopoda</b> ) (HMFEI pts = 1)	<input type="text"/>	Riffle Beetles ( <b>Dryopidae</b> , <b>Elmidae</b> , <b>Ptilodactylidae</b> ) (HMFEI pts = 2)	<input type="text"/>	Crane-fly Larvae ( <b>Tipulidae</b> ) (HMFEI pts = 3)	<input type="text"/>
Scuds ( <b>Amphipoda</b> ) (HMFEI pts = 1)	<input type="text"/>	Larvae of other Flies (enter name in comments) ( <b>Diptera</b> ): (HMFEI pts = 1)	<input type="text"/>	<b>EPT TAXA*</b> Total No. EPT Taxa = _____	
Water Mites ( <b>Hydracarina</b> ) (HMFEI pts = 1)	<input type="text"/>	Midges ( <b>Chironomidae</b> ) (HMFEI pts = 1)	<input type="text"/>	Mayfly Nymphs ( <b>Ephemeroptera</b> ) Taxa Present: HMFEI pts = _____ No. Taxa (x) 3] _____	<input type="text"/>
Damselfly Nymphs ( <b>Zygoptera</b> ) (HMFEI pts = 1)	<input type="text"/>	Snails ( <b>Gastropoda</b> ) (HMFEI pts = 1)	<input type="text"/>		
Alderfly Larvae ( <b>Sialidae</b> ) (HMFEI pts = 1)	<input type="text"/>	Clams ( <b>Bivalvia</b> ) (HMFEI pts = 1)	<input type="text"/>	Stonefly Nymphs ( <b>Plecoptera</b> ) Taxa Present: HMFEI pts = _____ No. Taxa (x) 3] _____	<input type="text"/>
Other Beetles ( <b>Coleoptera</b> ) (HMFEI pts = 1)	<input type="text"/>	Other Taxa :			
Other Taxa:		Other Taxa:		Caddisfly Larvae ( <b>Trichoptera</b> ) Taxa Present: HMFEI pts = _____ No. Taxa (x) 3] _____	<input type="text"/>
Other Taxa:		Other Taxa			

\*Note: EPT identification based upon Family or Genus level of taxonomy

Voucher Sample ID \_\_\_\_\_

Time Spent (minutes): \_\_\_\_\_

Notes on Macroinvertebrates: (Predominant Organisms; Other Common Organisms; Diversity Estimate)

---



---



---

Final HMFEI Calculated Score (Sum of All White Box Scores) =

IF Final HMFEI Score is > 19, Then CLASS III PWH STREAM  
 IF Final HMFEI Score is 7 to 19, Then CLASS II PWH STREAM  
 IF Final HMFEI Score is < 7, Then CLASS I PWH STREAM

# Appendix D

**(Taxa Data)**

Sample MI-13-001 (Permit C-807)

Order	Family	#collected
Diptera	Tipulidae	3
	Chironomidae	2
Plecoptera	Perlidae	1
Tricoptera	Philopotamidae	106
	Hydrophychidae	18
Megoptera	Coryalidae	1
Odonata Zycoptera	Caloptertgidae	1
Anisoptera	Corduliidae	1

Fish,Crayfish, and Salamanders

Black Nosed Dace (*R. atratulus*)

Common Creek Chub (*S. citromaculatus*)

Crayfish (*Cambarus Cavates*) (*Orconectes sanbornii*)

Northern Two-lined Salamander (*Eurycea bislineata*) (larval)

Sample MI-13-002 (Permit C-958)

Order	Family	#collected
Diptera	Tipulidae	1
	Chironomidae	1
Ephemeroptera	Baetidae	1
	Ephemerellidae	5
	Leptophlebiidae	5
Plecoptera	Perlidae	13
Tricoptera	Polycentropidae	1
	Hydrophychidae	2
Odonata Zycoptera Anisoptera	Calopterygidae	2
	Aeshnidae	1
	Petaluridae	1
	Cordulegastridae	1
Amphipoda		17

Salamanders and Crayfish

Crayfish (*Bartonii Cavates*)

Northern Two-lined Salamander (*Eurycea bislieata*)

## Sample ML-13-003 (C-1305)

Order	Family	
# Collected		
Diptera	Chironomidae	17
	Simuliidae	4
	Tipulidae	2
Megaloptera	Salidae	2
Odonata	Aesnidae	2
Coleoptera	Staphylinidae	8 (7 adults)
	Dytiscidae	4 (adults)
Orthoptera	Gryllidae	1(adult)
Hemiptera	Corixidae	10(adults)
Amphipoda		39
Isopoda		5
Flatworm		1

### Crayfish and Salamanders

Crayfish (*Bartonii cavates*) Northern Two-lined Salamander (*Eurycea bislineata*)

Sample MI-13-004 (Permit C-209)

Order	Family	#collected
Diptera	Tipulidae	8
	Chironomidae	3
Ephemeroptera	Baetidae	1
Plecoptera	Leuctridae	21
Tricoptera	Psychomyiidae	8
	Hydrophychidae	29
Megalopectera	Coryalidae	7
	Sialidae	3
Odonata Zycoptera	Coenagrionidae	2
Hemiptera	Corixidae	1
	Belostomatidae	1
Amphipoda		2
Isopoda		1

Fish and Crayfish

Black Nosed Dace (*R. atratulus*)

Common Creek Chub (*S. citromaculatus*)

Crayfish (*Bartonii Cavates*)

ML-13-005 (D-0019)

Order	Family	# collected
Diptera	Tipulidae	2
Plecoptera	Leuctridae	1
Tricoptera	Hydropterygidae	1
Hemiptera	Corixidae	2 adults
Coleoptera	Carabidae	1 adult

Crayfish and Salamanders

Crayfish (*Bartonia cavates*) and Northern Two-lined Salamander (*Eurycea bislineata*)

# Appendix E

**(Current DMRM Stream Guidelines)**



## **STREAM RECONSTRUCTION**

The FOCUSED TASKFORCE developed certain standard guidelines concerning "Stream Reconstruction." The "RECONSTRUCTED STREAM DESIGN GUIDELINES – Addendum to Part 3, H (4)" developed by the Taskforce are included in the APPENDICES, under the STREAM RECONSTRUCTION tab. Please refer to this APPENDIX for these details.

Included in the Appendix are 14 pages, which consist of:

General Guidelines concerning Design for a reconstructed stream (2 pages). Following this are twelve Attachment pages, showing various general guidelines and example plans that might be used for stream reconstruction, as site conditions allow. These are:

Reconstructed Stream Design – Attachment 1 Tables, which give approximate dimensions for post-mining reconstructed streams, depending on "Watershed Area" and "Slope" variations.

Attachment 2 – a Typical Cross-section of a reconstructed stream, with labels and definitions.

Attachment 3 – TYPICAL CHANNEL PROFILE for SLOPES GREATER THAN 4%.

Attachment 4 – TYPICAL MEANDER PATTERN for SLOPE RANGE 2-4%.

Attachment 5 – a Typical ROCK CHECK, Plan View and Cross-Section, with general guidelines.

Attachment 6 – a Typical GRAVEL RIFFLE, Plan View and Cross-Section, with general guidelines.

Attachment 7 – a Typical ROCK CHECK DAM, Cross-Section and Side view to show spacing.

Attachment 8 – a Typical LOG CHECK DAM, Plan View, Cross-Section and Side view to show spacing.

Attachment 9 – a Typical STRAW BALE CHECK DAM, Plan View, Cross-Section and Side view to show spacing.

Attachment 10 – a Typical WOVEN WILLOW CHECK DAM, Plan View and Cross-Section.

Attachment 11 – a Typical LOG GRADE STABILIZATION STRUCTURE, Cross-Section, Isometric and Side view to show spacing.

Attachment 12 – a Typical SANDBAG HEADCUT STRUCTURE, with Profile and Isometric views.

The Taskforce concluded that permitting requirements for both the topics of "Stream Reconstruction" and "Wetlands" are heavily influenced by other agencies, namely the United States Army Corps of Engineers (ACOE) and OEPA, with "401 /404 Permits." Both ACOE and OEPA rely on DMRM engineers to review and approve plans for these two topics. But certain aspects of permitting are different between agencies, and the requirements for final release by the ACOE and OEPA extend longer than DMRM's final bond release of a permit with either of these features. This impacts the decision to not require the inclusion of all or many of the materials submitted with "401/404 Permits" as part of the DMRM permitting process. Doing this could tie the coal company's bond release to aspects that the ACOE or OEPA have adopted, but which are not part of DMRM's requirements.

In developing these general guidelines, the Taskforce invited technical persons from the coal industry and contractors who have hands-on experience with reconstructing streams on mined areas to join us. Also, hydrologists from the DMRM staff joined a meeting via teleconferencing to share their views and concerns for reconstructing streams. These additional comments and experiences helped the Taskforce to arrive at a consensus of how to best address Stream Reconstruction in the permitting process. Experience was shared from both industry and DMRM inspection personnel who have seen various attempts at reconstructing streams. All agreed that the location of the reconstructed stream channel needs to be determined after observing where the "naturally occurring" erosional channels occur. This is why the general reconstruction process shown on the first page of the guidelines should be followed. To attempt to set a location during the initial permitting process, and then to hold that location as mandatory, would result in frustration and failure. Promoting successful stream reconstruction is why the Taskforce's guidelines say that the reconstructed stream will be located in the approximate pre-mining location, and that after they are reconstructed, their location will be shown on the Annual and Final Maps.

Likewise, experiences to date have demonstrated the dynamic nature of reconstructing streams – no one method works in all cases. This is why the Taskforce developed general guidelines and methods, and included numerous attachment drawings showing various types of materials to aid the process. All of these materials have been used in certain places to successfully reconstruct stream channels. But no method could be stated with certainty that it would work for a given stream. Experience has shown that some "trial and error" must be used, depending on the site conditions encountered.

As the Taskforce thoroughly discussed a great number of issues affecting the permitting process for Stream Reconstruction, the word "flexibility" came up often. Rigid guidelines will not be successful. Naturally occurring stream channels do not follow a typical pattern or match a pre-set profile. So reconstructed stream channels should not be expected to do these things.

DMRM inspection personnel shared that when reconstruction previously attempted to build a stream with a trapezoidal design using rock, it did not really function like a natural stream, and nature soon changed "this design" to suit its own purpose. Chief Erdos summed up a lengthy discussion during one meeting this way: "Don't lose sight of our goals. Our goal is to still meet the ORC, but to allow for flexibility to ease the permitting process and make it faster."

Everyone acknowledged that with stream reconstruction, the role of other agencies (ACOE and OEPA) with "401 /404 Permits" plays a significant part in the DMRM permitting process. ACOE and OEPA still rely on DMRM engineers to review and approve plans for stream reconstruction. However, these agencies want reconstructed streams to function reasonably close to natural streams. So once again, the Taskforce concluded that rigid permitting designs will not achieve the intended goal. For this reason, our general guidelines use words like "approximate" and "proposed location" for reconstructing streams. All agreed that the key points that needed to be addressed regarding permitting of stream reconstruction were: **length, stability, function and the Buffer Zone Variance (BZVR).**

The Taskforce discussed whether surveyed profiles would be required with the Application Map. The guidelines specify that these are not required. The Chief may request profiles for a particular need. The guidelines recognize that stream corridors will be graded during backfilling and grading operations, and that these must comply with approximate original contours (AOC) in all areas that have not previously been affected by pre-law mining. In areas previously affected by pre-law mining, the final grade must be stable and blend into the surrounding contours. We also discussed whether "As Built" drawings of reconstructed streams should be required. It was concluded that these would not be required. The highly variable features of streams caused by nature make such a task rather "short-lived" and do not serve the goal of flexibility. Rather, this could be problematic with DMRM inspection during bond release, and for the other agencies' inspections and approvals. The guidelines discuss "re-mining" permits, since site-specific conditions will most certainly apply to such cases. As stated, stream restoration may be impractical in some re-mining areas. There is no sense to construct dry channels that will not function as streams.

The Attachment 1 Tables were developed using "NATURAL CHANNEL DESIGN PROCEDURES..." November 1, 1999, which were developed by a Joint Working Group from industry and Ohio government agencies. Reconstructed stream variables of: "**bottom width of channel**" (b); "**bank full depth**" (dbf); "**depth of the flood prone area**" (dfp); "**meander width**" and "**meander length**" for slopes 4% or less; and "**pool to pool length**" for slopes greater than 4% were determined using the "NATURAL CHANNEL DESIGN PROCEDURES..." Quantity "Q" values (in cfs) were calculated using the SEDCAD 4.0 software. The curve number (CN) 85 was used. The Taskforce agreed that this CN was a valid input, since it represents a reasonable average of disturbed and undisturbed areas in typical mining permit areas. Quantity and velocity (in fps)

values were calculated for both 1.5 yr./ 6 hr. events (1.7") and 100 yr./ 6 hr. events (4.7"). SEDCAD 4.0 was used to calculate 1.5 yr. velocity, while Haestad Methods Flow Master was used to calculate 100 yr. velocity. These Tables should be used as a guideline to determine approximate dimensions for reconstructed streams, based on varying Watershed areas (in acres) and variable Slopes (in %). Once again it is stressed that these dimensions are approximate guidelines, and the actual reconstructed stream channel may be somewhat different, based on actual site conditions.

The Taskforce believes that these general guidelines for STREAM RECONSTRUCTION are based on "NATURAL CHANNEL DESIGN PROCEDURES..." previously developed and accepted, on hands-on experience that has proven successful, and on sound engineering principles were applicable. These are general designs and plans that allow reasonable flexibility in an area that certainly requires it. We believe that by following these general guidelines for reconstructing streams during the permitting and the reconstruction phases, the environment, the coal industry and DMRM personnel will be benefitted.

### **SUBSIDENCE CONTROL PLANS – AUGER and HIGHWALL MINING**

The FOCUSED TASKFORCE developed certain standard guidelines concerning "Subsidence Control Plans – Auger and Highwall Mining." The "AUGER and HIGHWALL MINING GUIDELINES" developed by the Taskforce are included in the APPENDICES, under the AUGER and HIGHWALL MINING tab. Please refer to this APPENDIX for these details.

In the Appendix, there are "Highwall Mining Plan Design" and "Auger Mining Plan Design" guidelines. Both of these are intended as Addendums to Part 4, E, Item 8, concerning the design and implementation of these respective mining plans. Also in the Appendix are the following three exhibits: "Exhibit 8A for Highwall Mining;" "Exhibit 8A for Auger Mining;" and "Exhibit 8B – Panel Layout Plan" for Highwall Mining.

If a permit application is submitted to request Highwall Mining (HWM), the permit preparer would follow the "HWM Plan Design" guidelines and submit the "Exhibit 8A for HWM." This exhibit table(s) would be compiled for the various overburden thicknesses, coal thicknesses, HWM entry width, and the HWM plan for number of entries between barrier pillars (20 is the maximum), etc. The Taskforce prepared these guidelines assuming that the permittee would

## Addendum to Part 3, H(4) - ABC Coal Company

### Reconstructed Stream Design

A reconstructed stream channel should be dynamic in that its various parameters will be changing. For example, rock lining will displace, pools will cut, sediment will deposit, banks will erode - all of which occurs continually in natural channels. Therefore, this design is meant to function as a guideline for stream reconstruction. Actual site conditions will vary and may necessitate changes in the design. Reconstructed stream channels will be observed during the maintenance period and changes in rock size, location, vegetation, grading and other features will be incorporated as needed with the goal of creating a reasonably stable "natural channel". The criteria around which streams will be reconstructed are that the length and function of intermittent and perennial streams should approximate pre-mining conditions.

### Application Map Requirements

1. No stream profiles are required to be submitted with the Application Map. Stream profiles may be requested by the Chief.
2. All pre-mining intermittent and perennial streams are to be shown on the Application Map, along with a table listing:
  - a. stream identifications for each stream within the permit limits
  - b. the length of each stream
  - c. an indication if the stream is intermittent or perennial
3. It is presumed that the reconstructed streams will be located at the approximate pre-mining locations. If any streams are to be relocated, include a map showing the approximate location(s) of the relocated stream(s).

### Annual and Final Map Requirements

1. If streams were present prior to mining, and are impacted by mining, they will be reconstructed as mining and reclamation progresses. As they are reconstructed, the location(s) of the reconstructed streams will be shown on the Annual and Final Maps, along with an indication of the reconstructed stream length.

For permits that propose to reclaim areas that have been left un-reclaimed as the result of previous pre-law surface mining, additional site specific conditions may apply. In some instances the reclamation of these pre-law mining areas could possibly replace stream restoration, instead of constructing dry channels that will not function as a stream.

The Attachment 1 Tables have been developed using Natural Channel Designs<sup>1</sup> for various site conditions. This table should be followed as a guideline to determine approximate dimensions for the post-mining reconstructed stream. These dimensions are approximate and the actual reconstructed stream channel may diverge from these measurements, and may vary depending on existing site conditions. **Also included are various examples (See included Attachments) of features that may be incorporated into the reconstructed stream channel, as site conditions allow.**

### The general reconstruction process is as follows:

1. The stream corridor will be formed (graded) at the time of backfilling and grading. These activities will follow the reclamation timetable stated in Part 3, D(1).
2. The corridor is defined as a swath roughly 20' to 100' in width which will function as the floodplain or flood prone area, and approximately follows the stream's pre-mining horizontal location.
3. The cross sectional grade across the floodplain should be essentially flat.
4. Once the corridor is graded and re-vegetated, it will be observed for naturally occurring erosional channels resulting from precipitation and runoff. The operator will develop the erosional channels with earthmoving activities to construct a channel that resembles a natural channel. The constructed channel will include such diverse features as variable horizontal and vertical alignments, pools, riffles, meanders, bottom width, top width, side slopes, undercut banks, substrate, and channel lining.

## Addendum to Part 3, H(4) - ABC Coal Company

5. Any rip-rap used as channel lining will be of a durable non-toxic and non-acidic nature. When rip-rap is used it will be appropriately sized per the listed 100 Yr/6 Hr velocity. Whenever possible, rock from the mine site should be used in the reconstructed channel. The Flood Prone Area will normally be vegetated only. When reconstructing stream channels, care should be exerted so as to create a natural looking stream channel and not a sterile rip-rapped ditch.
6. Details of features that are compatible with or typical of those used in natural stream design are shown on the following pages.
7. Following construction activities, the corridor will then be re-soiled and re-vegetated in accordance with the respective plans and schedules in the permit application.
8. The operator will perform frequent monitoring of channel paying particular attention to its stability. The intent is for the channel to achieve a reasonable degree of stability with the understanding that some erosion and sedimentation are expected in a natural channel. Examples of unacceptable stability are channels that are experiencing headcutting, severe downcutting or erosion.
9. It may be necessary for the operator to perform repair and maintenance work before the channel can be deemed acceptable.

### Calculation specifications for Attachment 1:

1. Q values were calculated using Sedcad 4.0, 1.5 Yr 6hr = 1.7", 100Yr 6hr = 4.7"
2. 1.5 Yr velocity was calculated using Sedcad 4.0
3. 100 Yr velocity was calculated using Haestad Methods Flow Master
4. A Natural Channel Design Procedure For Reconstructed Small Headwater Streams Within Coal Mine Operations in the Western Allegheny Plateau Ecoregion of Ohio was used to determine b, dbf, dfp, meander width and length for slopes 4% or less, and the pool to pool length for slopes greater than 4%.

---

<sup>1</sup> A NATURAL CHANNEL DESIGN PROCEDURE FOR RECONSTRUCTED SMALL HEADWATER STREAMS WITHIN COAL MINE OPERATIONS IN THE WESTERN ALLEGHENY PLATEAU ECOREGION OF OHIO. Developed by the Joint Working Group of the Coal Mining Industry, Ohio Environmental Protection Agency; and Ohio Department of Natural Resources, Division of Mines and Reclamation, and Division of Soil and Water Conservation: November 1, 1999

Addendum to Part 3, Item H(4)  
**Reconstructed Stream Design**  
 Attachment 1 Tables

These tables have been developed using Natural Channel Designs<sup>1</sup> for various site conditions. This table should be followed as a guideline to determine approximate dimensions for the post-mining reconstructed stream. These dimensions are approximate and the actual reconstructed stream channel may diverge from these measurements. Also included are various examples (See Included Attachments) of features that may be incorporated into the reconstructed stream channel, as site conditions allow.

Watershed (acres)	1.5 Yr/6 Hr Q (cfs)	100 Yr/6 Hr Q (cfs)	Slope <2%								
			b (ft)	d <sub>w</sub> (ft)	1.5 Yr Velocity (fps)	Channel Lining*	d <sub>b</sub> (ft)	W <sub>b</sub> (ft)	100 Yr Velocity (fps)	Meander Width (ft)	Meander Length (ft)
5	4.99	21.90	6.0	1.0	1.8	Vegetate	1.0	55	2.9	20	59
10	9.98	43.80	7.0	1.0	2.2	Vegetate	1.0	57	2.2	26	77
15	14.97	65.70	8.0	1.0	2.8	Vegetate	1.5	61	2.5	30	89
20	19.96	87.59	8.5	1.0	3.0	Vegetate	1.5	62	3.0	34	99
30	29.93	131.39	10.0	1.5	3.5	Vegetate	1.5	59	3.6	39	115
40	39.91	175.19	11.0	1.5	3.9	Vegetate	2.0	59	3.9	43	129
50	49.89	218.99	12.0	1.5	4.2	Vegetate	2.0	59	4.5	47	140
60	59.87	262.78	13.0	1.5	4.5	Vegetate	2.0	51	4.6	51	150
80	79.82	350.38	14.8	2.0	5.0	RipRap	2.5	58	4.9	56	167
90	89.80	394.18	15.0	2.0	5.1	RipRap	2.5	48	5.7	59	174
100	99.78	437.97	15.5	2.0	5.3	RipRap	2.5	49	5.8	61	181

Watershed (acres)	1.5 Yr/6 Hr Q (cfs)	100 Yr/6 Hr Q (cfs)	Slope 2% to 4%								
			b (ft)	d <sub>w</sub> (ft)	1.5 Yr Velocity (fps)	Channel Lining*	d <sub>b</sub> (ft)	W <sub>b</sub> (ft)	100 Yr Velocity (fps)	Meander Width (ft)	Meander Length (ft)
5	4.99	21.90	4.5	0.5	2.3	Vegetate	1.0	63	1.8	16	52
10	9.98	43.80	6.0	1.0	3.0	Vegetate	1.0	58	2.4	23	67
15	14.97	65.70	7.0	1.0	3.6	Vegetate	1.5	58	3.0	28	78
20	19.96	87.59	7.5	1.0	4.0	Vegetate	1.5	49	3.7	29	87
30	29.93	131.39	9.0	1.0	4.6	Vegetate	1.5	42	4.6	34	101
40	39.91	175.19	10.0	1.5	5.2	RipRap	1.5	45	5.0	38	113
50	49.89	218.99	10.5	1.5	5.6	RipRap	2.0	48	5.4	41	123
70	69.85	306.58	12.0	1.5	6.2	RipRap	2.0	50	6.0	47	139
80	79.82	350.38	13.0	1.5	6.4	RipRap	2.0	51	6.2	49	146
100	99.78	437.97	14.0	2.0	6.6	RipRap	2.5	57	6.7	54	159

Watershed (acres)	1.5 Yr/6 Hr Q (cfs)	100 Yr/6 Hr Q (cfs)	Slope 5%							
			b (ft)	d <sub>w</sub> (ft)	1.5 Yr Velocity (fps)	Channel Lining*	d <sub>b</sub> (ft)	W <sub>b</sub> (ft)	100 Yr Velocity (fps)	Pool to Pool Length (ft)
10	9.98	43.80	4.0	1.5	3.7	Vegetate	2.0	22	4.8	19
15	14.97	65.70	4.5	1.5	4.4	Vegetate	2.0	23	6.9	22
20	19.96	87.59	5.0	2.0	4.9	Vegetate	2.0	25	7.5	25
30	29.93	131.39	6.0	2.0	5.7	RipRap	2.5	29	7.9	29
40	39.91	175.19	6.5	2.0	6.2	RipRap	3.0	33	8.2	32
50	49.89	218.99	6.0	2.5	6.6	RipRap	3.5	39	9.1	37
80	79.82	350.38	8.0	3.0	8.8	RipRap	4.0	46	10.0	43
100	99.78	437.97	9.5	3.0	7.0	RipRap	4.0	48	10.3	49

Watershed (acres)	1.5 Yr/6 Hr Q (cfs)	100 Yr/6 Hr Q (cfs)	Slope 8% to 10%							
			b (ft)	d <sub>w</sub> (ft)	1.5 Yr Velocity (fps)	Channel Lining*	d <sub>b</sub> (ft)	W <sub>b</sub> (ft)	100 Yr Velocity (fps)	Pool to Pool Length (ft)
5	4.99	21.90	3.0	1.0	3.7	Vegetate	1.5	28	8.8	14
10	9.98	43.80	4.0	1.5	4.9	Vegetate	1.5	19	8.1	19
20	19.96	87.59	5.0	1.5	6.2	RipRap	2.0	23	8.9	24
30	29.93	131.39	6.0	2.0	6.5	RipRap	2.5	29	9.8	28
50	49.89	218.99	7.0	2.5	7.0	RipRap	3.0	36	11.1	34
70	69.85	306.58	8.0	2.5	7.7	RipRap	3.5	39	12.1	38
100	99.78	437.97	9.0	3.0	8.6	RipRap	4.0	45	13.3	44

Watershed (acres)	1.5 Yr/6 Hr Q (cfs)	100 Yr/6 Hr Q (cfs)	Slope 15%							
			b (ft)	d <sub>w</sub> (ft)	1.5 Yr Velocity (fps)	Channel Lining*	d <sub>b</sub> (ft)	W <sub>b</sub> (ft)	100 Yr Velocity (fps)	Pool to Pool Length (ft)
30	29.93	131.39	1.0	2.5	8.5	RipRap	2.0	23	11.9	17
50	49.89	218.99	2.0	2.5	9.0	RipRap	2.5	27	13.5	20
70	69.85	306.58	3.0	3.0	9.4	RipRap	3.0	33	14.7	23
100	99.78	437.97	4.0	3.0	10.3	RipRap	3.5	37	16.2	26

Watershed (acres)	1.5 Yr/6 Hr Q (cfs)	100 Yr/6 Hr Q (cfs)	Slope 20% to 25%							
			b (ft)	d <sub>w</sub> (ft)	1.5 Yr Velocity (fps)	Channel Lining*	d <sub>b</sub> (ft)	W <sub>b</sub> (ft)	100 Yr Velocity (fps)	Pool to Pool Length (ft)
30	29.93	131.39	1.0	2.5	9.1	RipRap	2.0	23	14.4	18
50	49.89	218.99	2.0	2.5	10.2	RipRap	2.5	27	16.4	19
80	79.82	350.38	3.0	3.0	11.6	RipRap	3.0	33	18.4	23
100	99.78	437.97	3.5	3.0	11.6	RipRap	3.0	34	19.4	25

Watershed (acres)	1.5 Yr/6 Hr Q (cfs)	100 Yr/6 Hr Q (cfs)	Slope 30% to 35%							
			b (ft)	d <sub>w</sub> (ft)	1.5 Yr Velocity (fps)	Channel Lining*	d <sub>b</sub> (ft)	W <sub>b</sub> (ft)	100 Yr Velocity (fps)	Pool to Pool Length (ft)
40	39.91	175.19	1.0	2.5	11.1	RipRap	2.0	23	17.6	18
70	69.85	306.58	2.0	2.5	11.8	RipRap	2.5	27	20.2	20
100	99.78	437.97	3.0	3.0	12.7	RipRap	3.0	33	22.1	23

*Addendum to Part 3, Item H(4)  
Reconstructed Stream Design  
Attachment 2*

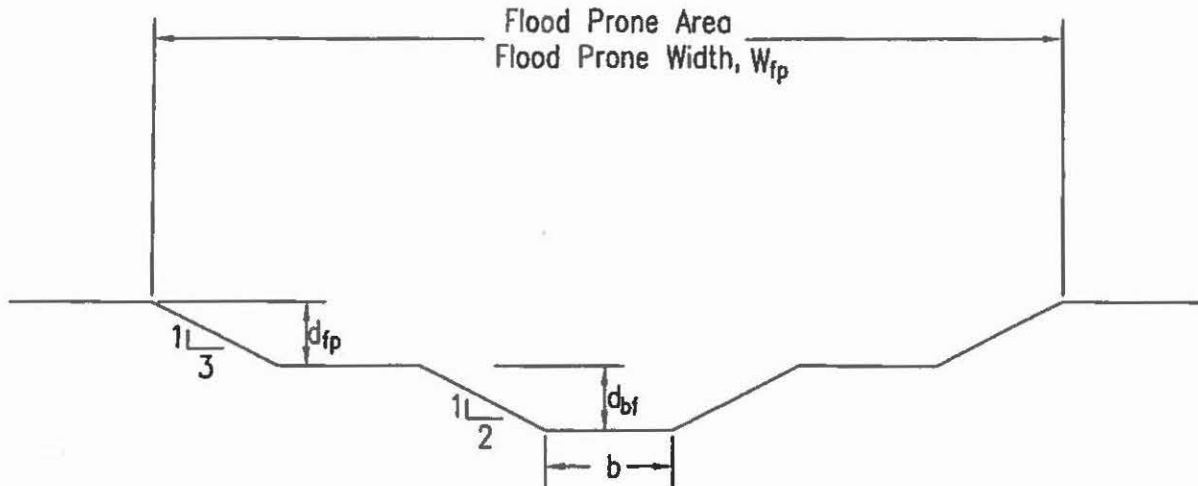

**TWO-STAGE CHANNEL**

**Low Flow Channel:**

*The capacity of the Low Flow Channel shall handle the 1.5 year 6 hour storm.*

*The flow length of the low flow channel should equal the original channel length.*

*Minimize use of riprap armored channels. If used, the riprap above the normal low flow should be covered with soil and planted.*

**Flood Prone Area:**

*The capacity of the Flood Prone Area plus the Low Flow Channel shall handle the 100 year 6 hour storm.*

*Encourage natural vegetation in the Flood Prone Area for the benefits of water quality, bank stability and wildlife.*

*Flood Prone Areas shall have side slopes approximating 3:1, however variable slopes are preferred.*

**Definitions:**

*b - Bottom width of the channel to handle the 1.5 Yr. storm event*

*d<sub>bf</sub> - Bank full depth of the channel to handle the 1.5 Yr. storm event*

*d<sub>fp</sub> - Depth of the flood prone area*

*W<sub>fp</sub> - Width of the flood prone area*



**TYPICAL CHANNEL PROFILE  
FOR  
SLOPES GREATER THAN 4%**

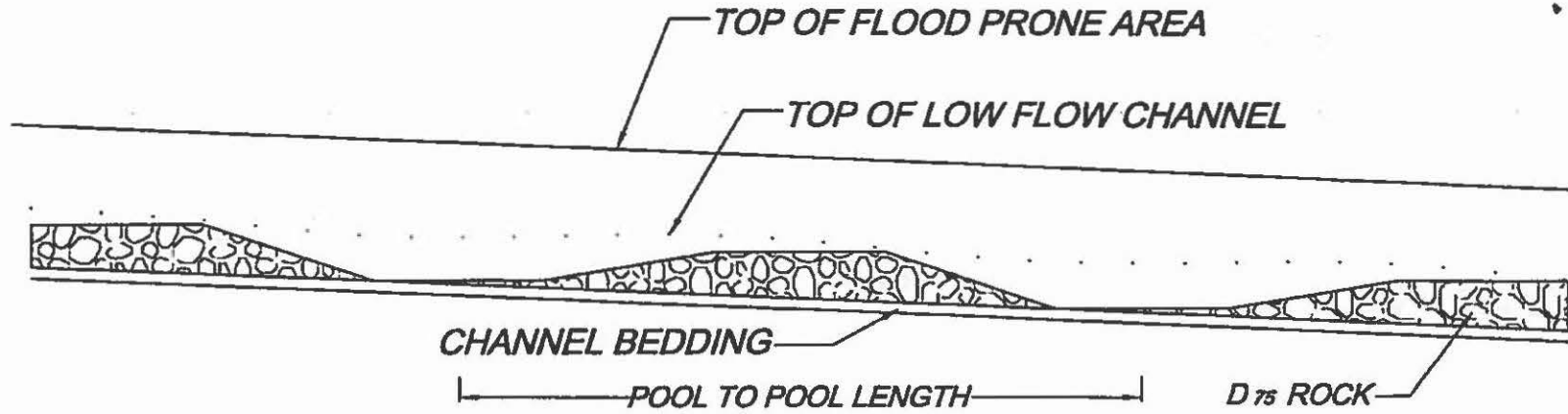

*DRAWING NOT TO SCALE*

TYPICAL MEANDER PATTERN  
FOR  
SLOPE RANGE 2-4%

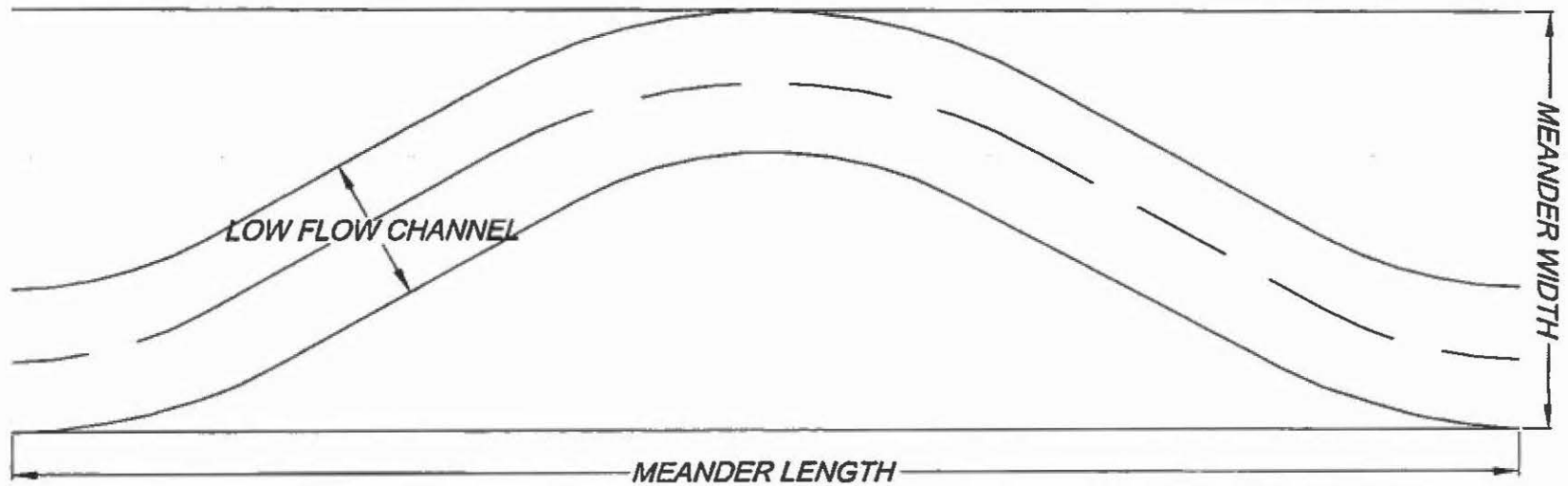

DRAWING NOT TO SCALE

Addendum to Part 3, Item H(4)  
Reconstructed Stream Design  
Attachment 4

Rev. 1-23-2013

Addendum to Part 3, Item H(4)  
Reconstructed Stream Design  
Attachment 5

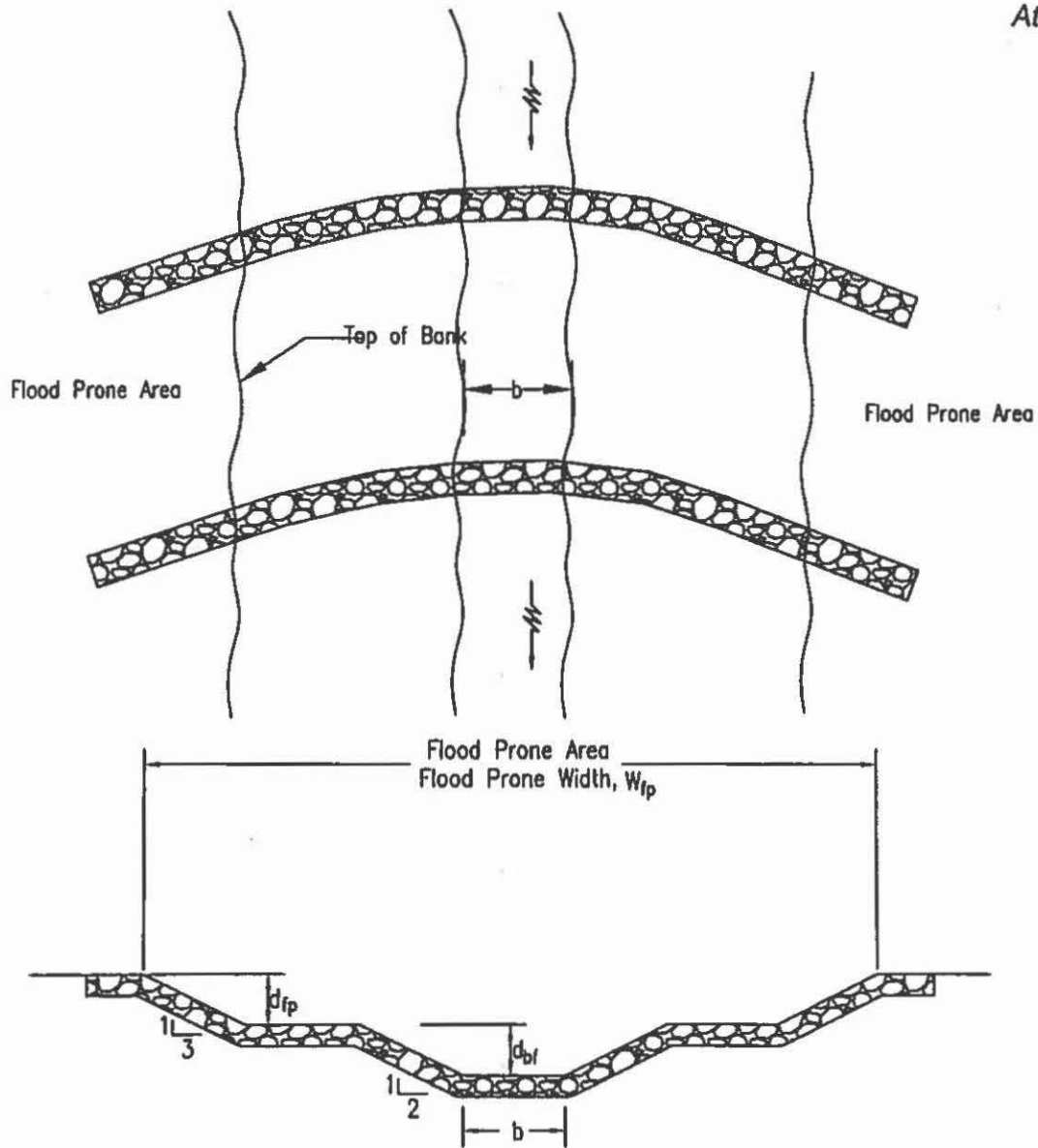

## ROCK CHECK

*Appropriately sized durable rock shall be used.*

*The ends shall extend from the top of the channel into the banks 10 ft. or a distance equal to about one-half the channel width, whichever is less.*

*The trench shall be 1 to 2 ft. wide and shall be dug to arc or form a vee pointing upstream with the midsection of the rock check farther upstream than where it meets the channel bank.*

*The rock check shall be flush with the channel so that the finished rock surface is on the same grade as the channel bottom and not creating a dam or ponding water.*

Addendum to Part 3, Item H(4)  
 Reconstructed Stream Design  
 Attachment 6

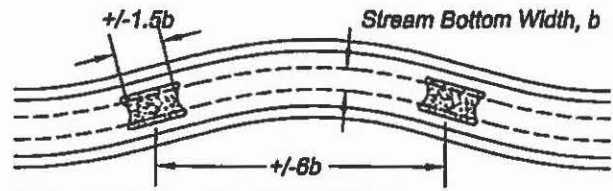

Spacing of 5 to 7 times Stream Bottom Width (b)  
 Length = +/- 1.5 times Stream Bottom Width (b)

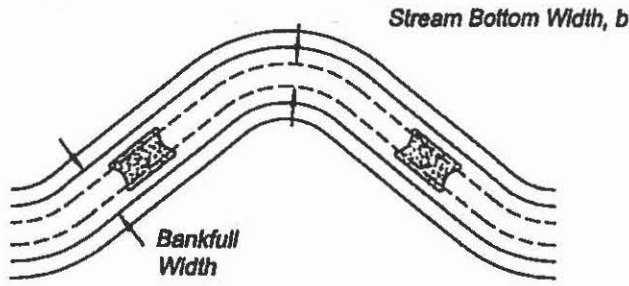

Cross Over of Meander

**GRAVEL RIFFLE PLACEMENT AND SPACING**

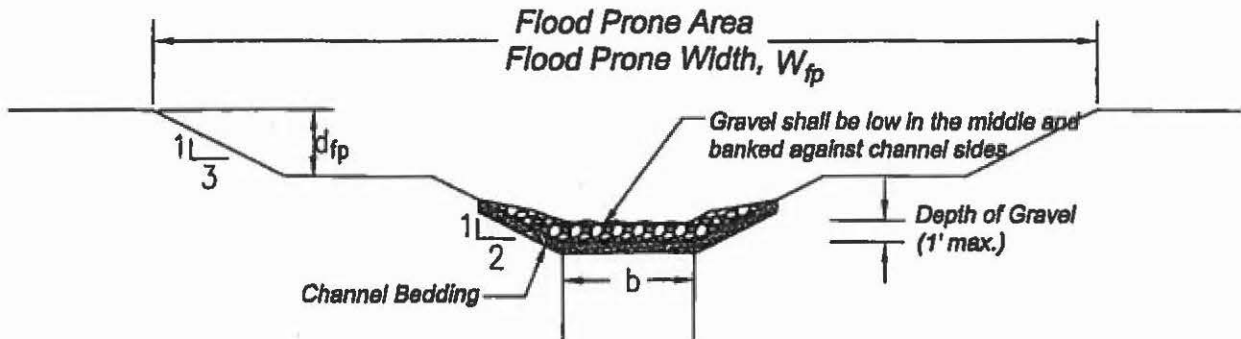

**GRAVEL RIFFLE**

The length of gravel riffle shall be equivalent to 1.5 times the stream bottom width, b.

The gravel shall NOT be placed so that it acts as a dam or creates a backwater pool. It shall be generally less than 1 ft. thick and no higher than the Max. Riffle Depth.

The gravel shall be placed so that it is slightly lower in the middle and higher by the streambanks.

Gravel size shall be similar to the substrate from the former stream channel. The gravel will be stable at bankfull flow but erodible at Q100 flow.

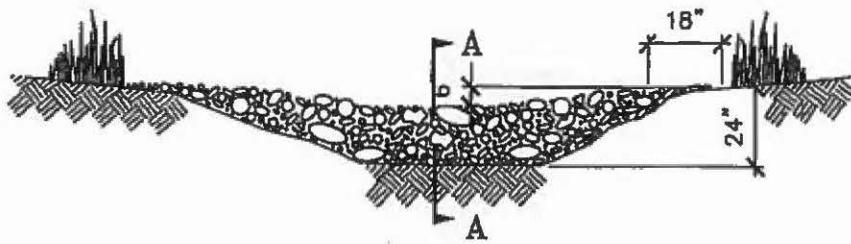

VIEW LOOKING UPSTREAM

NOTE:  
KEY STONE INTO THE DITCH BANKS  
AND EXTEND IT BEYOND THE ABUTMENTS  
A MINIMUM OF 18" TO PREVENT OVER  
FLOW AROUND DAM.

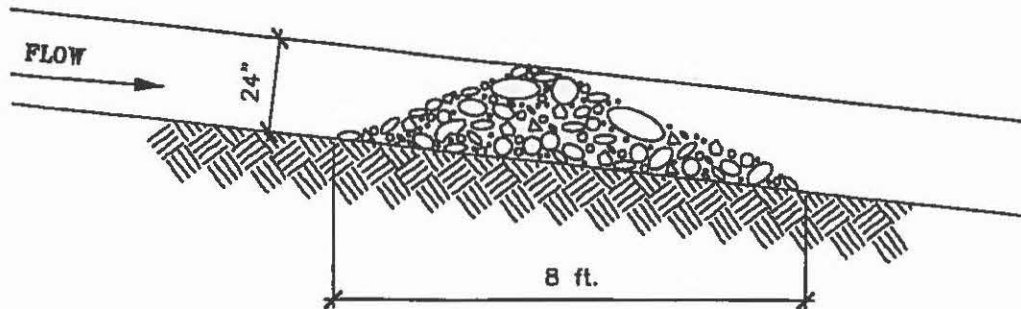

SECTION A - A

'L' = THE DISTANCE SUCH THAT POINTS 'A' AND  
'B' ARE OF EQUAL ELEVATION.

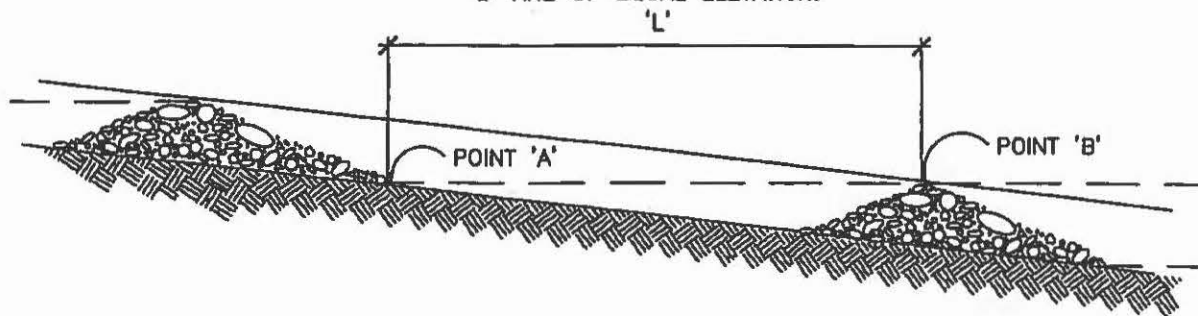

SPACING BETWEEN CHECK DAMS

ROCK  
CHECK DAM

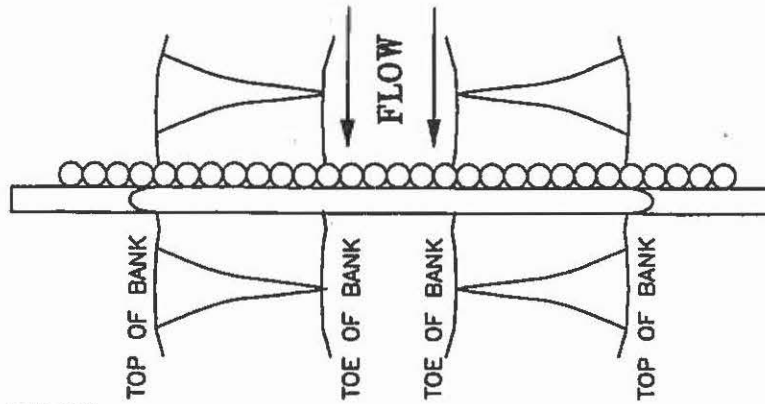

PLAN VIEW

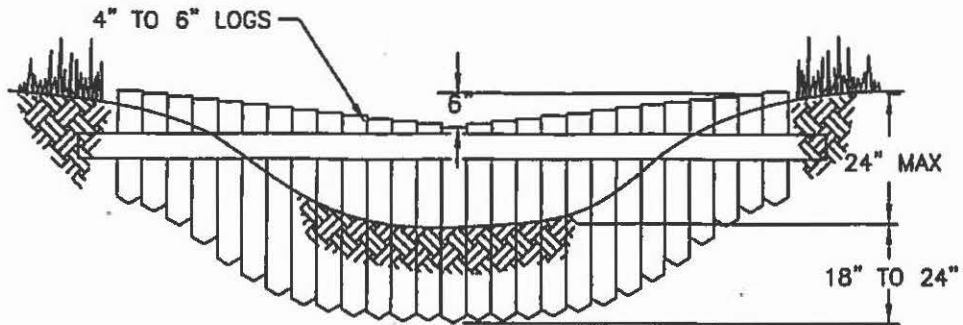

VIEW LOOKING UPSTREAM

'L' = THE DISTANCE SUCH THAT POINTS 'A' AND 'B'  
ARE OF EQUAL ELEVATION

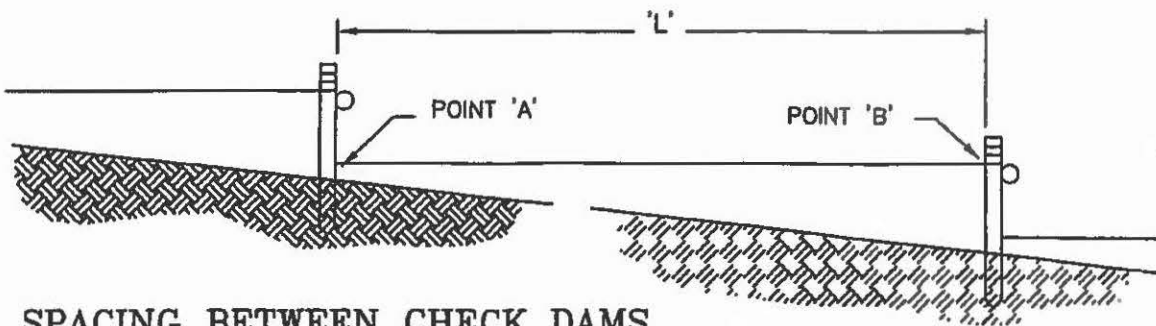

SPACING BETWEEN CHECK DAMS

NOTE:  
KEY THE ENDS OF THE CHECK  
DAM INTO THE CHANNEL BANK.  
LOGS SHALL BE PRESSURE  
TREATED IF GRADE STABILIZATION  
STRUCTURE IS INTENDED TO BE  
PERMANENT.

LOG  
CHECK DAM

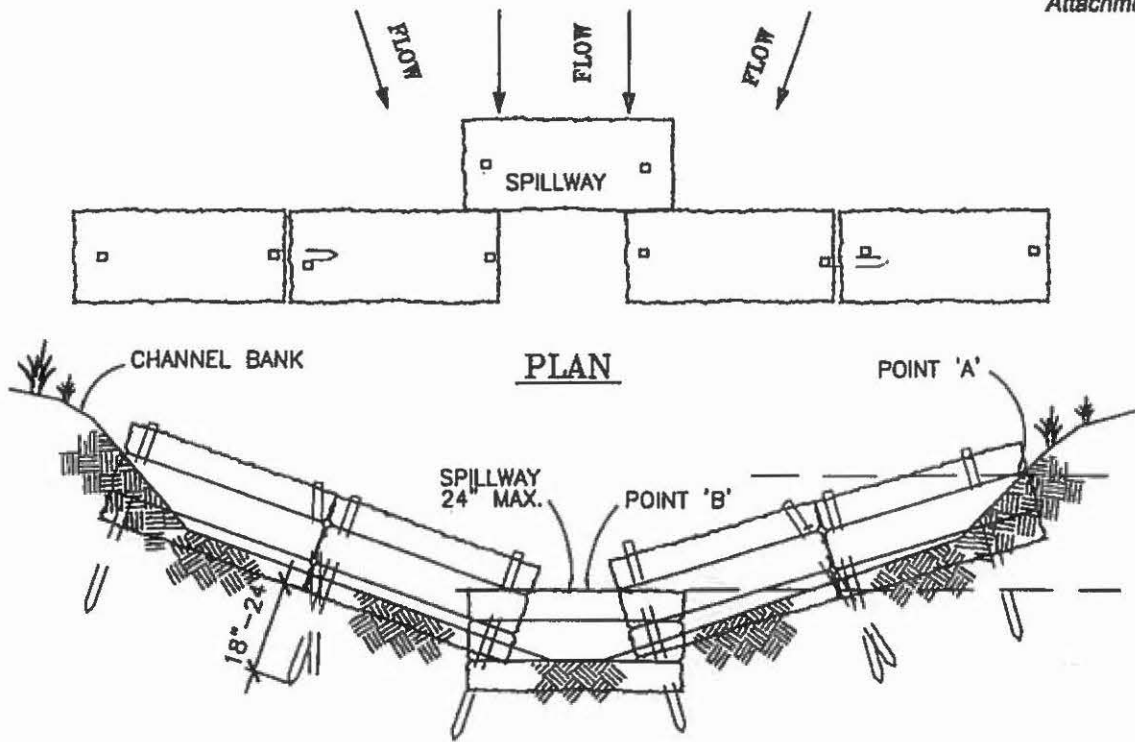

**VIEW LOOKING UPSTREAM**

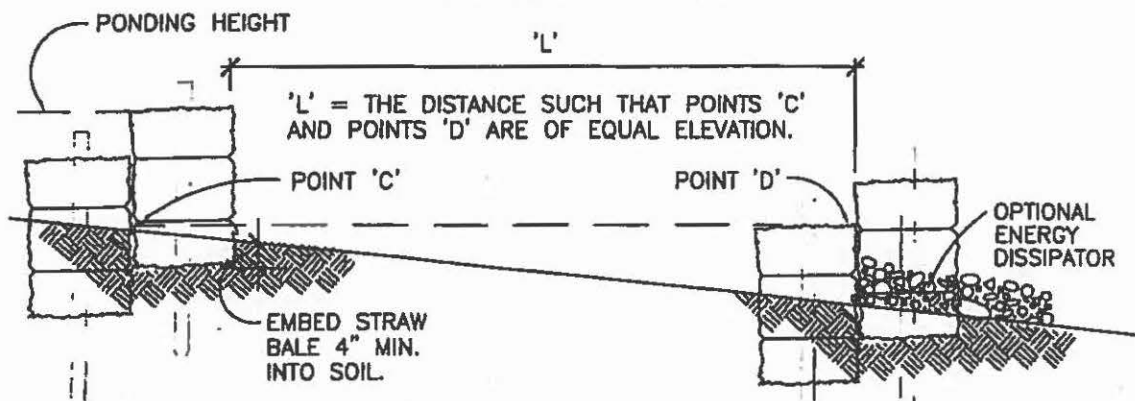

**SECTION A - A**  
**SPACING BETWEEN CHECK DAMS**

**NOTES:**

1. EMBED BALES 4" INTO THE SOIL AND 'KEY' BALES INTO THE CHANNEL BANKS.
2. POINT 'A' MUST BE HIGHER THAN POINT 'B'. (SPILLWAY HEIGHT)
3. PLACE BALES PERPENDICULAR TO THE FLOW WITH ENDS TIGHTLY ABUTTING. USE STRAW, ROCKS OR FILTER FABRIC TO FILL ANY GAPS AND TAMP BACKFILL MATERIAL TO PREVENT EROSION OR FLOW AROUND THE BALES.
4. SPILLWAY HEIGHT SHALL NOT EXCEED 24".
5. INSPECT AFTER EACH SIGNIFICANT STORM, MAINTAIN AND REPAIR PROMPTLY.

**STRAW BALE  
CHECK DAM**

WILLOW CUTTING AND PLANTING  
SHOULD BE PERFORMED WHEN  
PLANT MATERIAL IS DORMANT.  
(NOVEMBER - APRIL)

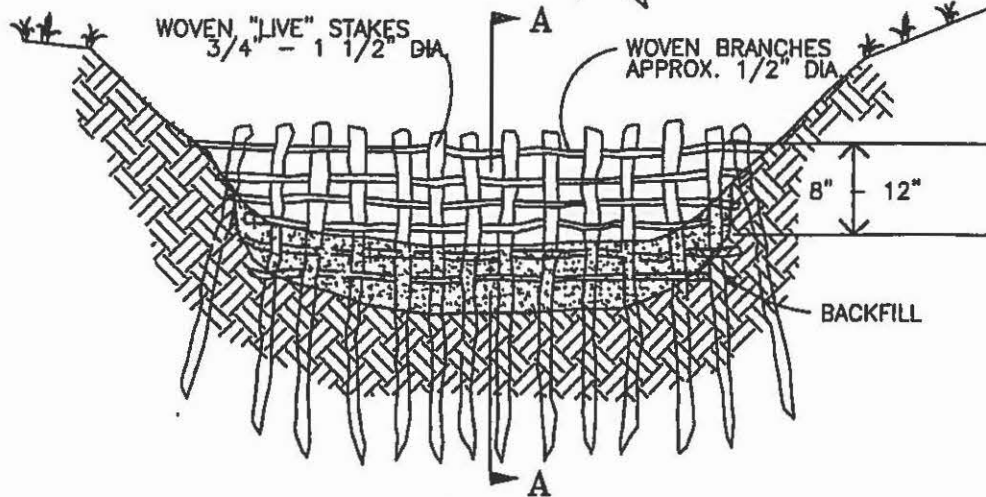
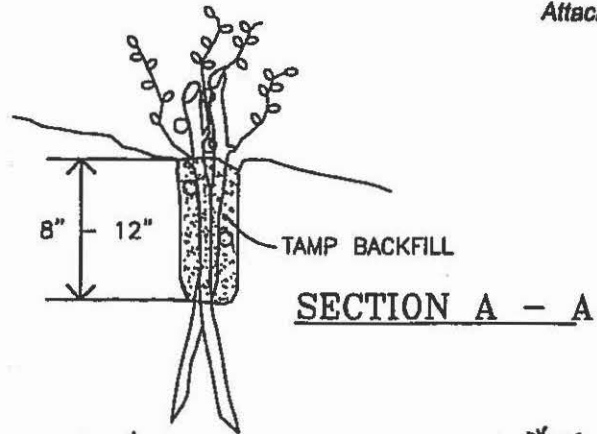

**SECTION B - B**

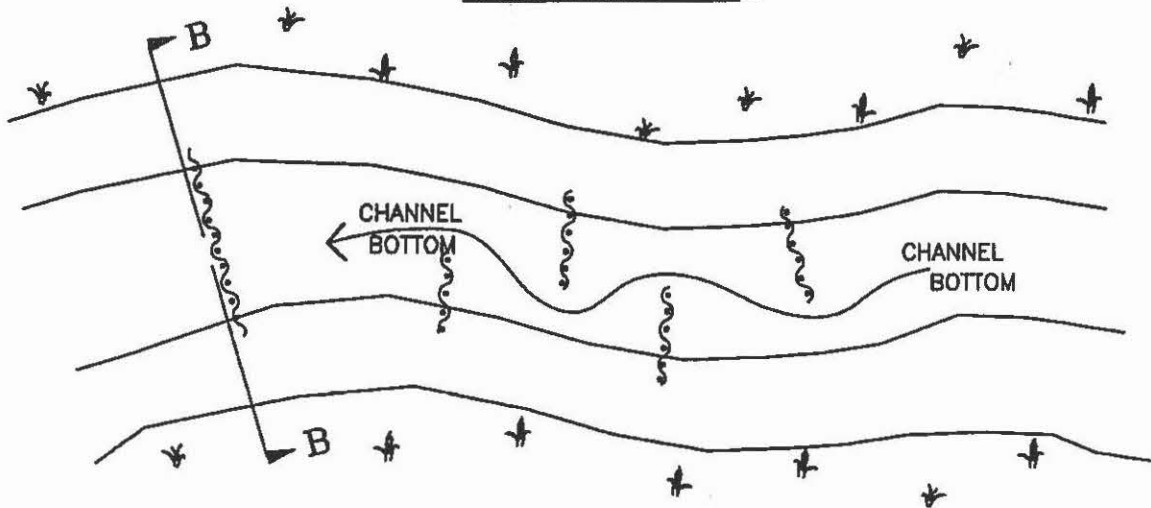

WOVEN WILLOW (LIVE) CHECKDAMS  
ACT AS VELOCITY DISSIPATORS  
TO REDUCE GULLY DOWNCUTTING

**WOVEN WILLOW  
CHECK DAM**



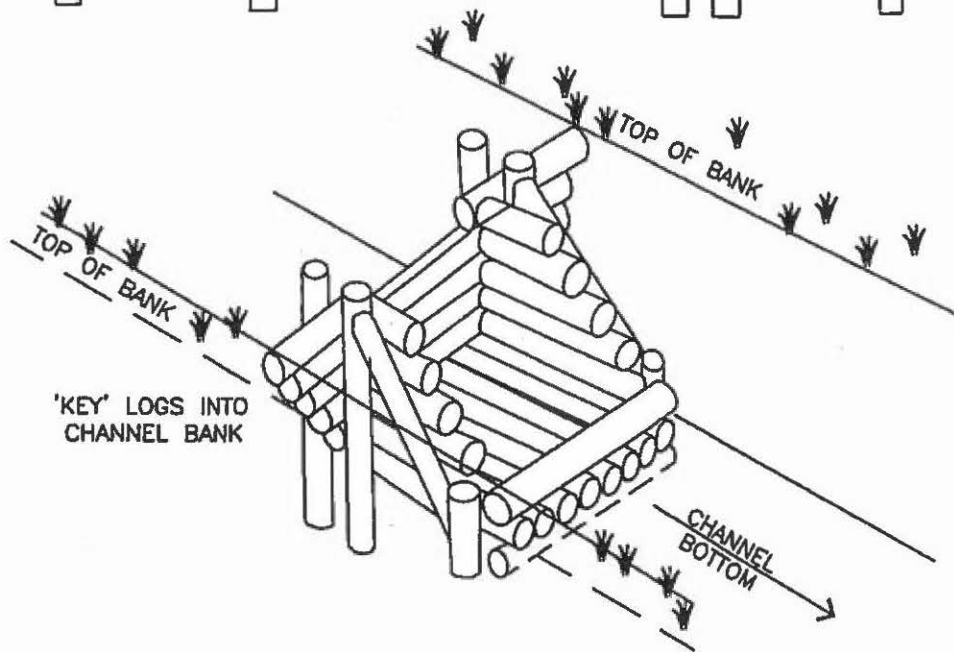
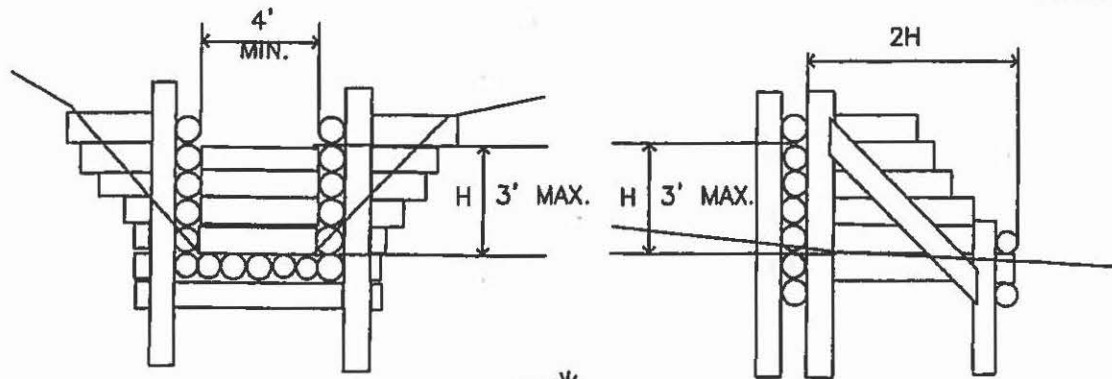

'L' = THE DISTANCE SUCH THAT POINTS 'A' AND 'B' ARE OF EQUAL ELEVATION

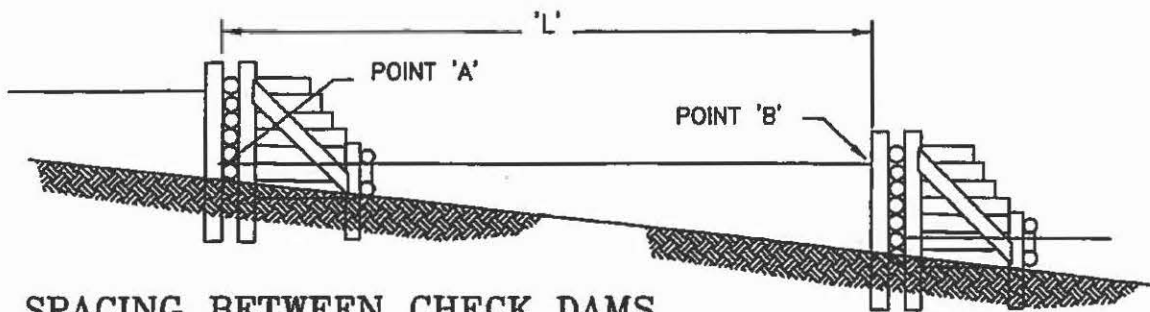

SPACING BETWEEN CHECK DAMS

LOG GRADE  
STABILIZATION  
STRUCTURE

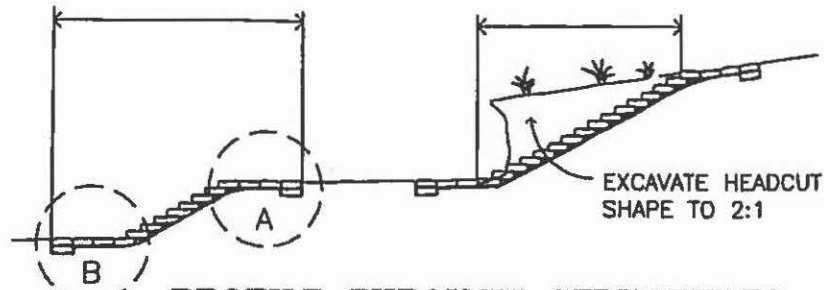

PROFILE THROUGH STRUCTURES

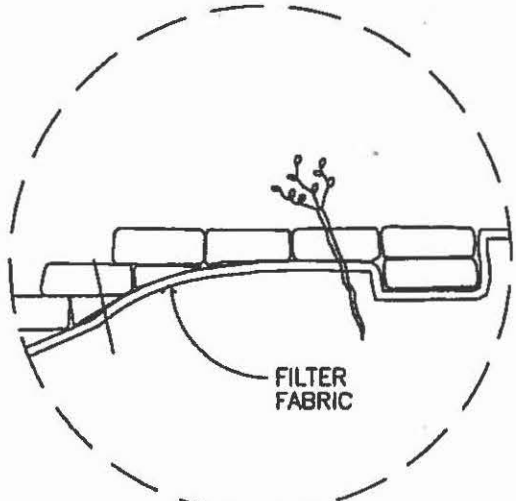

DETAIL - 'A'

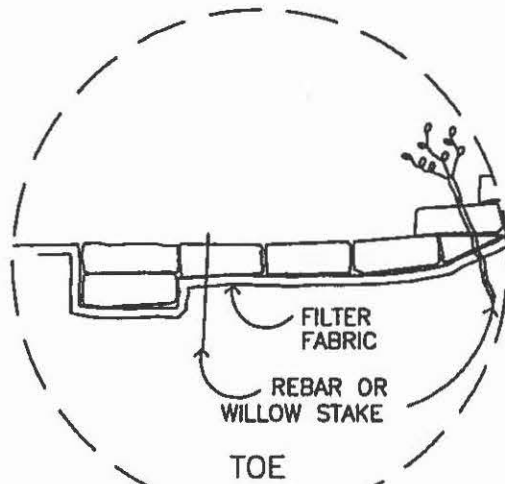

DETAIL - 'B'

BURLAP SACKS FILLED WITH  
4 PARTS SAND - 1 PART CEMENT  
OR GEOTEXTILE SANDBAGS  
FILLED WITH SAND/SOIL.

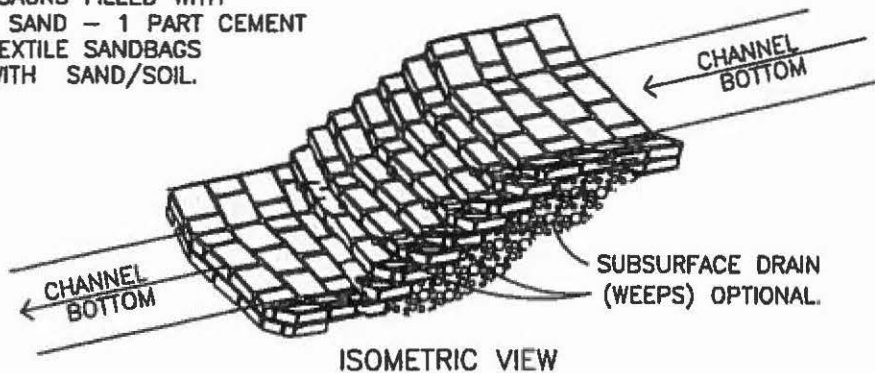

ISOMETRIC VIEW

SANDBAG HEADCUT STRUCTURE

NOTES:

1. GEOTEXTILE SANDBAGS MAY BE STAKED WITH LIVE WILLOW STAKES, REBAR OR 'SNAP TIE' STAKES SHOULD BE USED WITH CEMENT SANDBAGS.
2. ROCK RIPRAP MAY BE USED IN PLACE OF SANDBAGS.

**SANDBAG  
HEADCUT  
STRUCTURE**

# Appendix F

**(Stream Study 2015 Photos)**

**Ohio Power C-0209**



C-0209– subwatershed for reconstructed stream channel



C-0209– (12-1-2013) looking down stream of reconstructed channel

DMRM Stream Study 2015 Photo Gallery



C-0209 (12-1-2013) – midstream looking upstream of reconstructed channel



C-0209– End of reconstructed stream segment, water sampling and soils boring sites

**B&N Coal D-0958**



D-0958– reconstructed stream channel



D-0958– reconstructed stream channel water and soil sampling site

DMRM Stream Study 2015 Photo Gallery



D-0958– reconstructed stream channel



D-0958– reconstructed stream channel looking downstream

DMRM Stream Study 2015 Photo Gallery



D-0958– Bio-consultant Max Luhrs conducting biological sampling



D-0958 Bio - view of stream channel substrate near the end of the bio segment



DMRM Stream Study 2015 Photo Gallery



D-0807– planning work for reconstructed stream channel



D-0807– Consultant Max Luhers and DMRM hydrologist Cheryl Socotch evaluating reconstructed stream segment

DMRM Stream Study 2015 Photo Gallery



D-0807– reconstructed stream channel at end of stream segment



D-0807– reconstructed stream segment at mid-point of stream segment showing isolated pools

DMRM Stream Study 2015 Photo Gallery



D-0807– at end of stream segment looking upstream



D-0807– view of reconstructed stream substrate

DMRM Stream Study 2015 Photo Gallery



D-0807– view of substrate near the upper end of reconstructed stream segment

**Valley Mining C-1305**

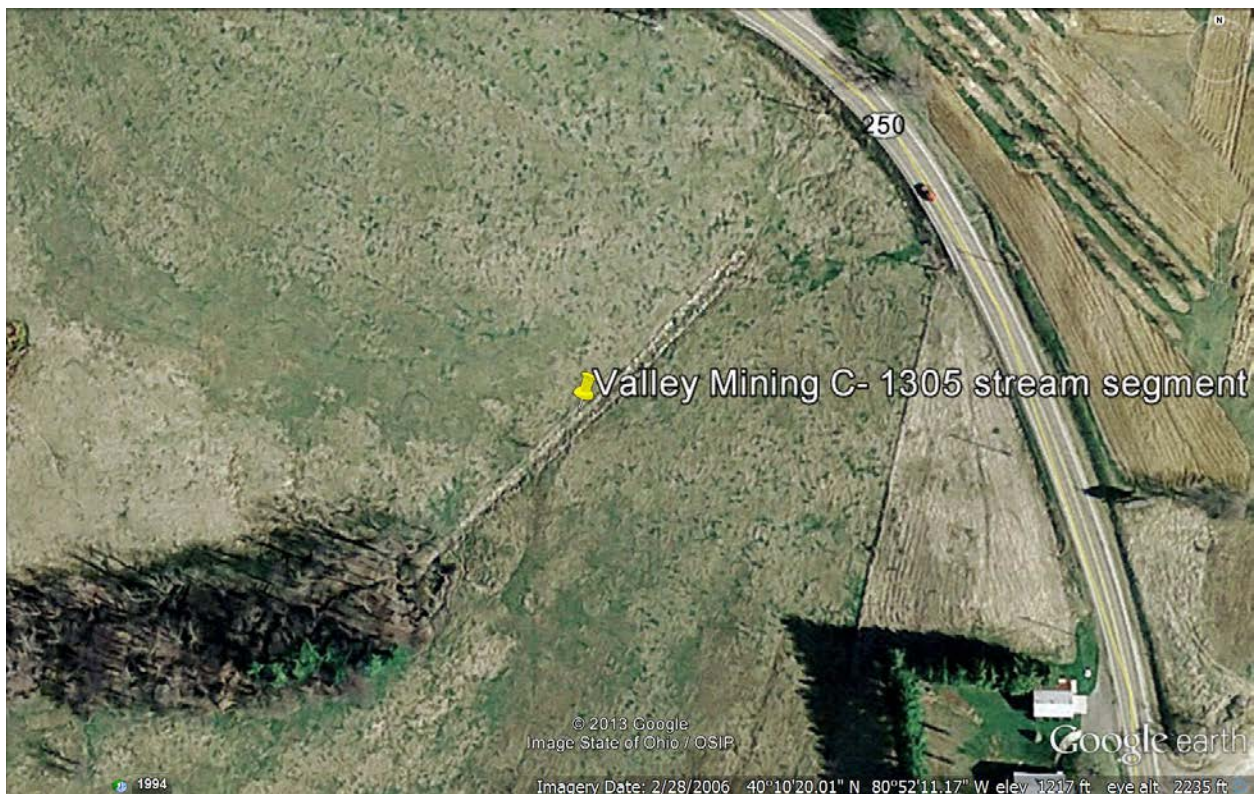

C-1305– aerial view of reconstructed stream segment

DMRM Stream Study 2015 Photo Gallery



C-1305– looking upstream from the lower end of reconstructed stream segment



C-1305 (12-22-2013) – near end of reconstructed stream segment and transition into wooded area

DMRM Stream Study 2015 Photo Gallery



C-1305 (12-22-2013)– reconstructed stream channel flowing through unaffected wooded area located immediate below



C-1305 Bio– OSU consultant Robert Baker, and DMRM intern Missy \_\_\_? Conducting HHEI survey of bio segment

**Wills Creek Energy D-019**



D-019 Bio– OSU consultant Max Luhers and DMRM hydrologist Laura Bibey conducting biological survey



D-019 Bio

DMRM Stream Study 2015 Photo Gallery



D-019 Bio- pond outlet and plunge pool at the head of the biological segment



D-019 Bio- riparian corridor of bio segment



DMRM Stream Study 2015 Photo Gallery



D-019 Bio- Pond above Bio segment



D-019- reconstructed stream segment looking downstream

DMRM Stream Study 2015 Photo Gallery



D-019– midway point looking upstream of reconstructed stream segment



D-019– above midway point of reconstructed stream segment looking upstream