



Ohio Department of Transportation
Division of Engineering
Office of Structural Engineering (OSE)
Snooper Operations Manual

Revised March 2025



Office of Structural Engineering
1980 West Broad Street (MS5180)
Columbus, Ohio 43223

<https://www.transportation.ohio.gov/working/engineering/structural/home>

Table of Contents

I. Overview	1
II. Organization and Responsibilities.....	4
III. Bridges Requiring a Snooper Inspection	14
IV. Scheduling.....	17

Figures

Figure 1 - Snooper Bucket Deployed for Right-Side Operation	1
Figure 2 - Snooper Truck	3
Figure 3 - ODOT Organizational Chart	4
Figure 4 - On-Site Responsibility	5
Figure 5 - District Bridge Inspection Operations	6
Figure 6 - Truck Mounted Attenuator (TMA).....	8
Figure 7 - Shoulder may be utilized with appropriate clearance on a case-by-case basis	9
Figure 8 - MT SCD Example Sheet	10
Figure 9 - Division of Engineering Snooper Operations.....	11
Figure 10 - Deployed Bucket.....	17
Figure 11 - Bridge Scheduling Priority.....	17
Figure 12 - Authority for Comprehensive Changes to Snooper Schedule	21

I. Overview

The Ohio Department of Transportation (ODOT) is responsible for the oversight of all federally qualified bridges in the State per Title 23 CFR-650 subpart C. These are bridges that carry public vehicular traffic and whose clear span is greater than 20-feet in length. ODOT has direct inspection authority for more than 14,000 Ohio qualified bridges on or over the State Highway System per Ohio Revised Code 5501.47. These are bridges whose clear span are greater than or equal to 10-feet in length. Many bridges do not have adequate access to structural components because a river, a deep valley or the feature intersected prohibits visibility or entry. One vital operation used to support the professional inventory and inspection of bridges

in Ohio is a specialized truck that provides quick, safe, and easy access to many critical components of the structure that are otherwise inaccessible (Figure 1). ODOT operates and maintains two under bridge inspection vehicles (Aspen Aerials) and the operation is coordinated



Figure 1 - Snooper Bucket Deployed for Right-Side Operation

by Central Office in the Office of

Structural Engineering (OSE). For the purpose of this document the under bridge inspection vehicles shall be referred to as Snooper Trucks.

1. Staffing Levels

Bridge Specialists (BS) from the Office of Structural Engineering (OSE) currently operate two Snooper Trucks. For the purposes of this manual the term Operators will be used to identify the Central Office Bridge Specialists. Equipping each truck with two trained Operators from the Bridge Specialist series is vital not only for the truck transport and mechanical operation but also for the professional inspection of the in-service bridges.

- Transport - two operators allow one to drive the Snooper and the second to drive and offer support in the chase or 'support' vehicle.
- Inspection - At minimum, a two-person operation is required when the snooper is deployed; one person in the bucket and one person available on top of the bridge.

Alternates are permitted to fill in on a case-by-case basis however one trained Operator must be with the truck during inspection or transport at all times.

Inspections that require any of the following activities shall be performed using a 3-person operation (two people in the bucket and one trained Operator on the topside) to promote the integrity of the inspection and ensure the safety of the inspector and vehicular traffic:

- | | | |
|--------------------|------------------|------------|
| • Night inspection | • Load-rating | • In-Depth |
| • NSTM | Inspection | Inspection |
| Inspection | • Scoping | • Complex |
| • Any Bridge | • Confined space | Inspection |
| Maintenance | | |

2. Safety

Only trained people shall operate the Snooper equipment. A body harness and lanyard shall be always worn and connected to the bucket cleat when operating from the bucket. Employees shall stand on the floor of the bucket and not sit or climb on the edge of the bucket or use ladders in the bucket. The boom and bucket load limits specified by the manufacture shall not be exceeded.

While certain inspections may dictate special personal protective equipment requirements all jobs require permitted protective clothing which is defined as follows: Hard Hat, Safety Vest ANSI II or III (depending on day vs. night and low vs. high speed traffic), T-Shirt with non-altered sleeves that cover the shoulder and upper bicep, long pants such as jeans, sturdy leather boots/shoes that cover, protect, and support the ankle.

When working over water from the snooper truck personnel are not required to use a personal flotation device (PFD) or provide a rescue boat for maintenance activities, including inspection, as long as they are 100% tied off at all times. Life vests are located on the truck with at least 90 feet of line at all times when working over water and will be available.

All non-participating inspection vehicles and equipment should be parked off the roadway. If other means are impractical and appropriate traffic control exists, vehicles can be parked inside the safe work zone at the discretion of the technicians setting the traffic control zone.

3. The Trucks

The department currently owns two units a 2019 A62 Aspen Aerial, and a 2009 A62 Aspen Aerial rebuilt in 2021 with a new chassis. The current A-62 snooper has a maximum reach of 61'-9" horizontally under a bridge, a 10' fence clearance, a maximum 13' sidewalk clearance, and a maximum working super elevation of 8%. Refer to Appendix A for the Flight Diagram. It can be deployed from the right or left side of the truck. The basket capacity is 600 lbs. and is equipped with compressed air and wired for 110-volt electricity.



Figure 2 - Snooper Truck

The vehicle has a Gross Vehicle Weight (GVW) of approximately 66,200 lbs. or 33.1 tons and, when driving, a width of 8', a vertical clearance of 12'-11" and a length of 40'. Refer to Appendix A for the footprint and axle loads.

II. Organization and Responsibilities

Conducting a Snooper inspection on a State Route (see “Local Agency Responsibilities” within this section for non-State Routes) requires significant advanced planning with three unique divisions within ODOT, each with a distinctive chain of command (Figure 3).

- **District, Planning and Engineering (P&E)** – Technical Lead
- **District, Highway Management (HM)** – Implementing the Temporary Traffic Control (TTC)
- **Central Office, Office of Structural Engineering (OSE)** – Snooper Truck and Scheduling

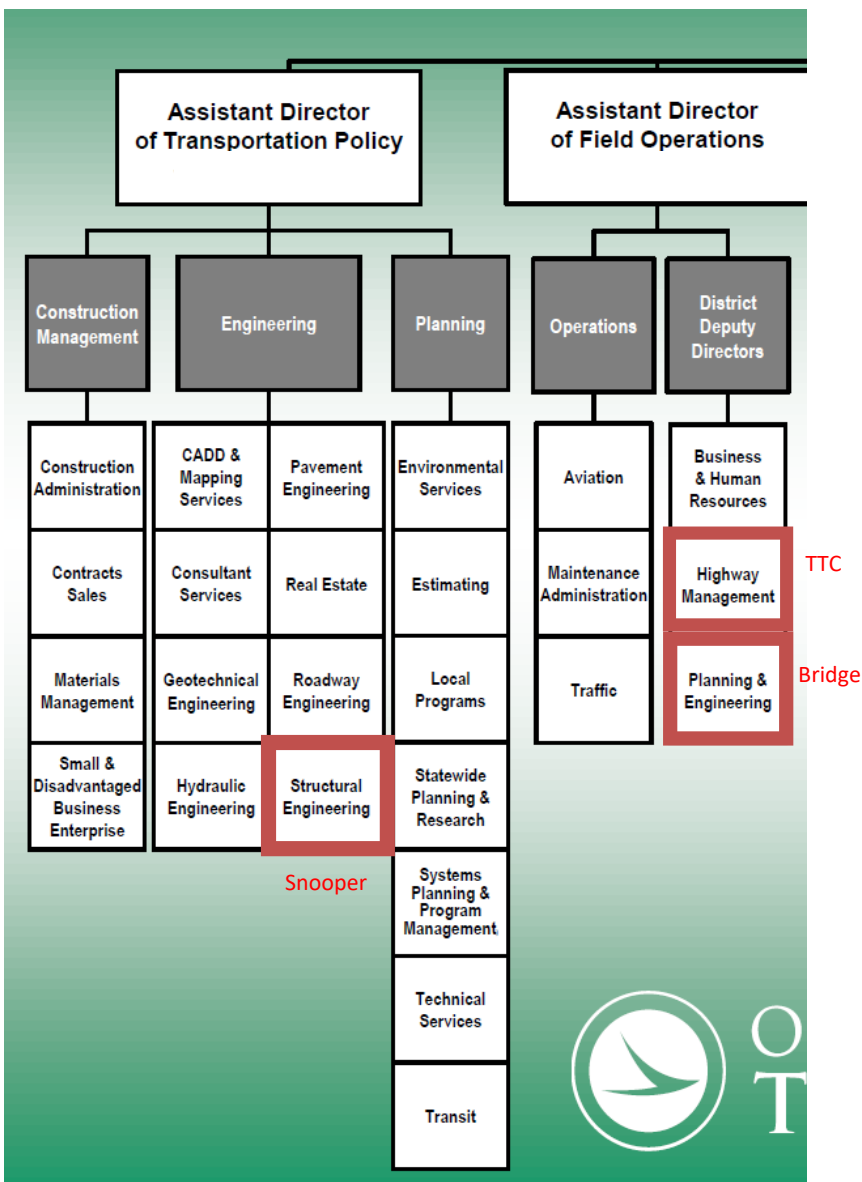

Figure 3 - ODOT Organizational Chart

Methodically and efficiently navigating through a bridge inspection and into the next temporary traffic control zone is a team effort. ODOT Personnel onsite from the District, Central Office and County are expected to contribute their best effort toward ensuring the safety of the traveling public, ensuring safety of the personnel in and around the traffic control zone, and optimizing the snooper truck usage. This will most likely require the District and/or the County switching to four-ten-hour-days (4-10's Monday-Thursday), coordinating two adjacent zones and in general being flexible and communicating with the Team Leader.

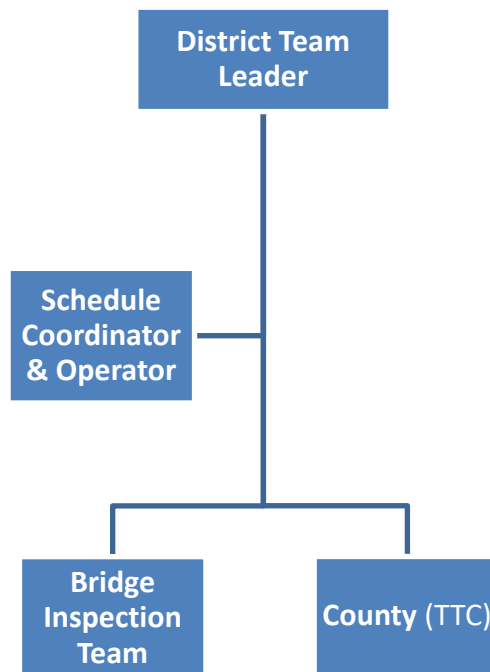

Figure 4 - On-Site Responsibility (Operator will function as alternate Team Leader when mutually agreed upon between OSE and DBE)

The Bridge Specialist 2 (BS2) onsite shall be the inspection Team Leader (TL) and is the one individual in charge of planning, preparing, and performing (or while onsite delegating team activities) field inspection of the bridge; of which Snooper-access is one part. It is imperative that the Team Leader relays accurate, appropriate clear direction to the traffic control and the inspection team. Any unsafe traffic control conditions should be corrected before performing the inspection. They must ensure the inspection conforms to National and State standards while public safety and inspector safety is maintained.

Delays more than 30 minutes incurred due to incorrect signage, substandard MOT or hours waiting for the Truck Mounted Attenuators (TMA's) must be communicated from the Team Leader to Highway Technicians in the field and their immediate supervisor, TM or TA by phone while onsite. Delays in excess of 60 minutes shall also be communicated from the Team Leader to the HMA.

1. District Planning and Engineering Responsibilities

District Bridge Engineers are the Program Managers and function as the technical lead for the bridges in their jurisdiction. They personally review and stamp the vast majority of the inspection reports. They are the individual assigned the duties and responsibilities for bridge inspection, reporting, and inventory. They provide overall leadership and are available to inspection team leaders to provide guidance. The District is responsible for:

- Identifying and inventorying bridges that require under bridge access
- Assign Snoopers
- Determine inspection Frequency
- Determine estimated inspection time
- Assign Schedule
- Coordination and funding of flagman or permits to access bridges over rail roads, local roads or within municipalities

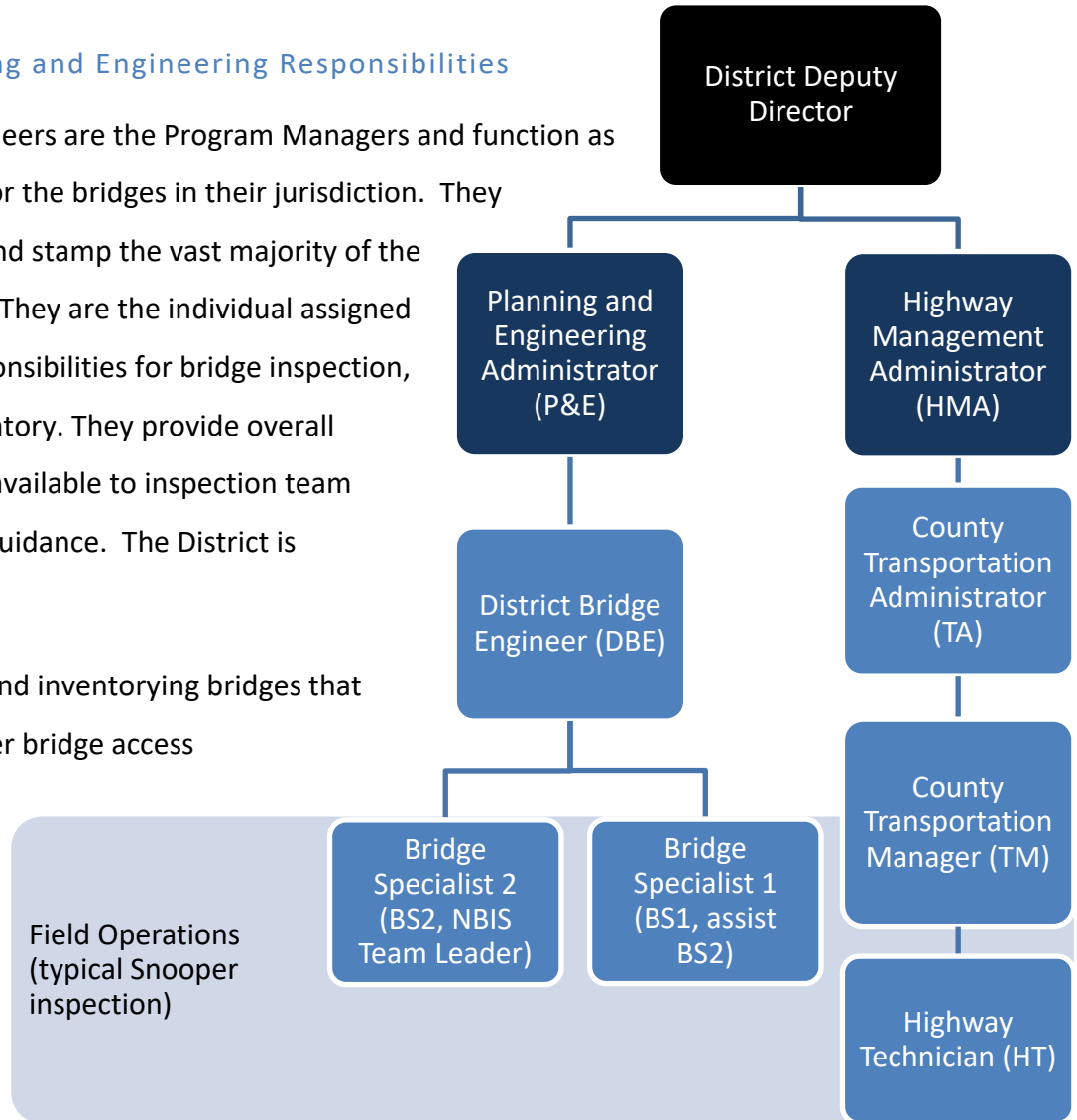

Figure 5 - District Bridge Inspection Operations

- Coordinating with the counties that provide traffic control
- Providing evening storage locations
- Providing equipment maintenance support as necessary
- Providing an alternate equipment operator or transport as necessary
- Providing the NSTM Inspection Procedure when an NSTM inspection is scheduled
- Scheduling the removal of debris, trees and shrubs for the snooper access
- Press releases, when necessary, when lane(s) are reduced due to anticipated snooper usage
- Participate in training and daily operations to develop backup operators and mechanics
- Assigning Team Leader, providing Bridge Specialists as agreed upon

The District is the technical lead for the bridges on State Routes in their jurisdiction, therefore the District BS2, as designated by the District Bridge Engineer (if not designated then the most senior District BS2), will function as the technical lead for the inspection when BS2's from different offices are present.

a) District Staff Augmented with OSE Staff

Snooper Operators may perform the inspection if requested in writing by the District Bridge Engineer and mutually agreed-upon by OSE; denoted with "CO" on the schedule, prior to the inspection cycle. These inspection reports will be approved in AssetWise by the OSE Bridge Inspection Engineer unless directed otherwise by the DBE. The "CO" request must be mutually agreed upon before the schedule is finalized in March in order to allocate appropriate resources and other District requests.

Operators and District Bridge Specialists may also share inspection tasks denoted with a "SH" on the schedule with a written request from the District Bridge Engineer before the schedule is finalized. "SH" indicates that the Operator will perform a routine inspection, unless directed otherwise, within the flight path of the bucket and share their photos, notes and maintenance recommendations (e-mail, AssetWise created report or shared-drive) to the District Bridge Specialist. Specific methods of sharing must be communicated among Bridge Specialists. The district will follow up within a reasonable time-frame in the same year to perform the ground-

work by walking, using a ladder or operating a bucket truck in order to finalize and submit the inspection. If “CO” or “SH” is established for a bridge it is expected that the District will not be onsite unless there is a specific request due to an emergency or questionable bridge defect. In cases “CO” is agreed-upon and where the District Bridge Specialist is in attendance then the “SH” protocol will be followed.

2. District Highway Management: County Responsibilities

The County shall be responsible for supplying and implementing the temporary traffic control in accordance with the department’s Temporary Traffic Control (TTC) Manual.

Transportation Managers are encouraged to be present on the first day the Snooper is in the County to ensure a smooth start to the MOT operations and verify the TTC meets minimum standards.



Figure 6 - Truck Mounted Attenuator (TMA)

Snooper operations run most proficiently in

Districts where TM’s take an active role and when the MOT is transferred to the absolute fewest number of counties i.e. when HT’s cross county. The most proficient Districts provide one MOT team capable of setting up multiple TTC’s throughout the District to allow the Snooper operation to move out of one zone and into the next.

Delays more than 30 minutes incurred due to incorrect signage, substandard MOT or hours waiting for the Truck Mounted Attenuator (TMA) must be communicated from the Team Leader to Highway Technicians in the field and their immediate supervisor, TM or TA, by phone while onsite. Delays in excess of 60 minutes shall also be communicated from the Team Leader to the HMA. All delays must be coded appropriately in the time management system.

Daytime inspections are typically used. Day inspection can be limited by Permitted Lane Closure (<http://plcm.dot.state.oh.us/>) for shortened windows of time. Night work is an option but poses new and different challenges. Night work can be more dangerous and more time consuming and should include Police detail.

a) The Following are required at each Snoopers Inspection

- **Truck Mounted Attenuators (TMA's).**
- **Our crash attenuator (TMA) requirements have changed due to using unballasted TMA's. Please communicate these changes with traffic control in advance. We now require the following:**
- **1 TMA for speeds less than 60 mph preferably attached to a tandem axle truck.**
- **2 TMA's for speeds equal to or greater than 60 mph preferably attached to tandem axle trucks.**

- The one exception to this rule is a complete road closure (MT-101.60).
- *Established TTC plan.* The Maintenance of Traffic Standard Construction Drawings (MT-SCD) shall be

used, and each bridge shall have a MT-SCD assigned and executed at each snoopers inspection.

These traffic standards are located within the Office of Roadway Engineering website

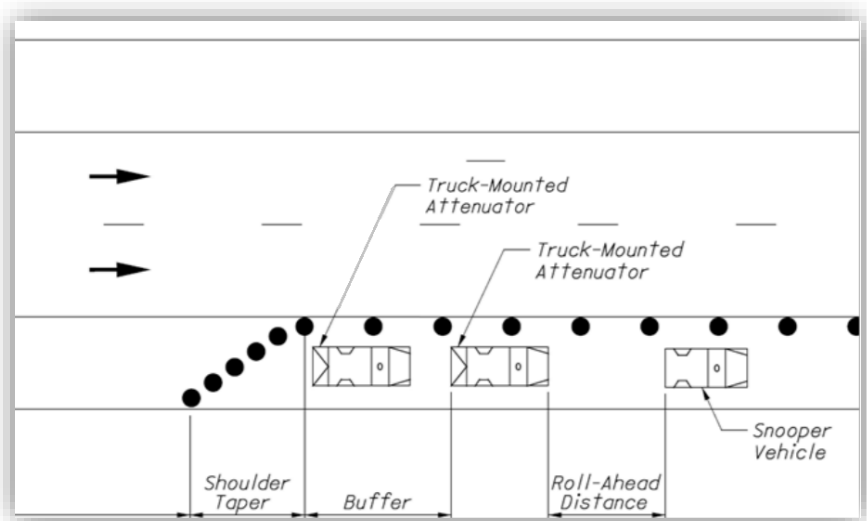

Figure 7 - Shoulder may be utilized with appropriate clearance on a case-by-case basis

([http://www.dot.state.oh.us/Divisions/Engineering/Roadway/DesignStandards/traffic/SCD/Pages/CurrentMaintainingTraffic\(MT\)SCDs.aspx](http://www.dot.state.oh.us/Divisions/Engineering/Roadway/DesignStandards/traffic/SCD/Pages/CurrentMaintainingTraffic(MT)SCDs.aspx)). Shoulders may be used with no road channelization only when horizontal clearance is sufficient in the TTC zone, and the Operator approves depending upon safety and boom clearance. Some of the more common standards for the Snooper Operation include the following:

*Common MT SCD's for Snooper Operations**

1. MT-95.30 Closing Right or L. Lane of a Multi-Lane Divided Highway*
2. MT-95.31 Closing Right Lane of a Multi-Lane Undivided Highway*
3. MT-97.11 Flagger Closing 1 Lane of a 2-Lane Highway-Stat. Operation*
4. MT-101.60 Road Closure Using Type 3 Barricades
5. Ramps:
 - a) MT-98.10 Lane Closure at Entrance Ramp*
 - b) MT-98.11 Lane Closure at Entrance Ramp Acceleration Lane*
 - c) MT-98.20 Lane Closure at Exit Ramp*
 - d) MT-98.22 Lane Closure in Deceleration Lane*
 - e) MT-98.28 Lane Closure with Exit Ramp*
 - f) MT-98.29 Exit Ramp Closure*

*** TMA Required**

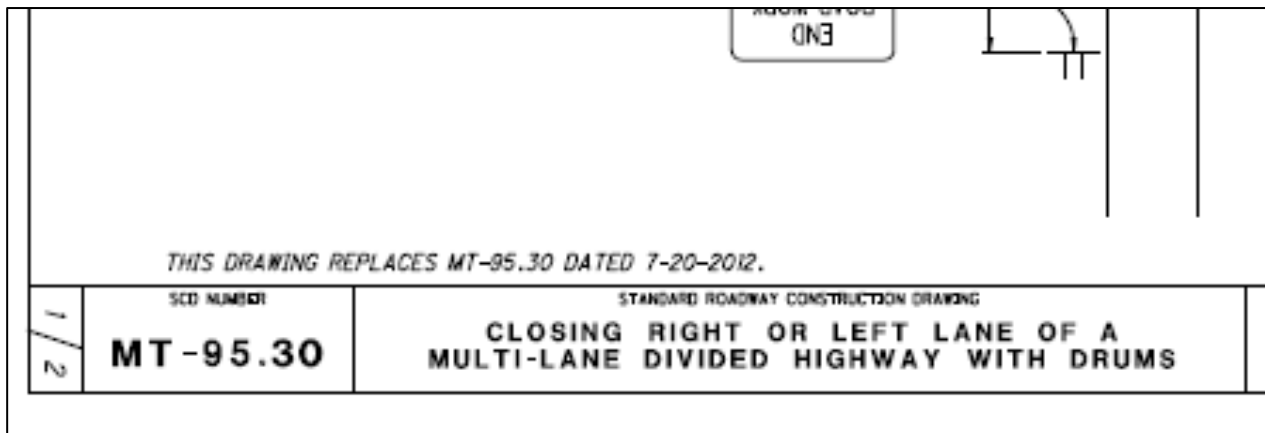

Figure 8 - MT SCD Example Sheet

3. The Office of Structural Engineering Responsibilities

The scheduling, operating, training and maintenance for the under bridge inspection equipment and program is primarily within the Office of Structural Engineering. This involves optimizing the route, communicating with advance notice, coordinating with 30-45 County TTC crews, and District bridge operations. Approximately 190-250 bridges per year will be inspected using one of the snoopers. Central Office supplies operators from the Bridge Specialist series to staff the snoopers truck.

Snooper Operators must make three phone calls, at a minimum, when District and County arrival dates are as scheduled. More phone calls or emails may be required when changes are anticipated.

1. Snooper Operators must call the District Bridge Engineer the week prior to arrival into the District notifying them of anticipated arrival dates, start time for the first bridge, Team Leader responsibilities, expectations etc.

2. Snooper Operators must call the County Manager (TA) or Local Agency Traffic Control **one week in advance** prior to arrival in their jurisdiction.

3. Snooper Operators must call the County Manager (TA) or Local Agency Traffic Control **one working day** (or as close as reasonable) before arrival into their jurisdiction

(reminders such as TMA, TTC plan, truck storage, location, changes due to construction, start time, unique MOT, potential 4-10's must be communicated)

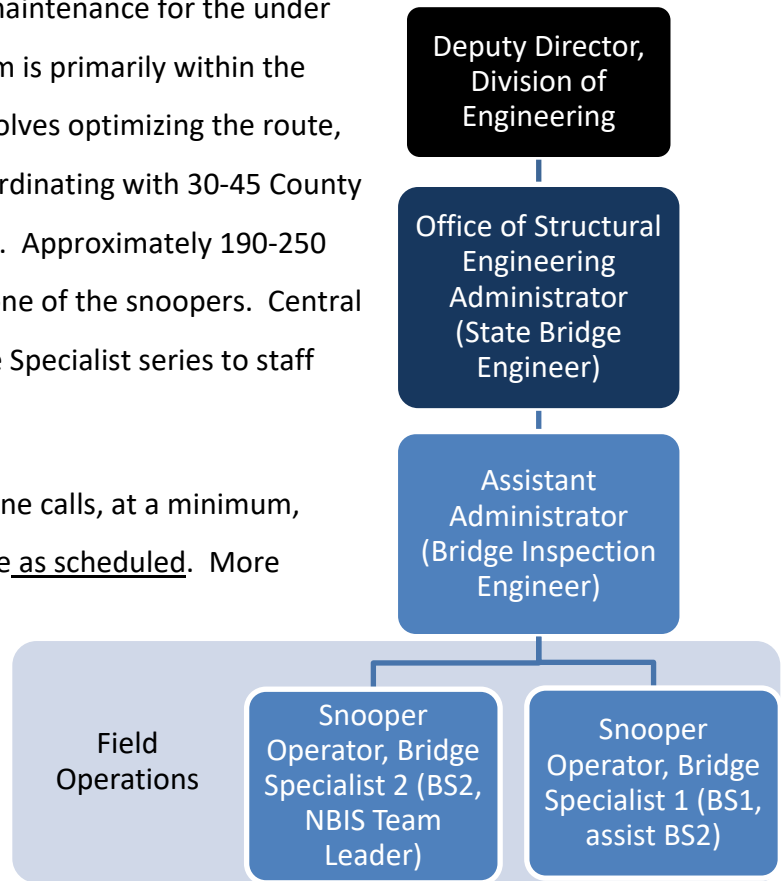

Figure 9 - Division of Engineering Snooper Operations

4. Local Agency Responsibilities

Requests for Snooper usage must be made in December of the previous year and must be made by the public entity with inspection responsibility as designated by the Ohio Revised Code.

Request must be made through:

- County or Township Bridges: The County Engineer's Association of Ohio (CEAO) QA/QC representative
- Municipal Bridges: The Local Bridge Program Manager in the Office of Structural Engineering (Cities and Villages)

The schedule will be populated with up to 40 County and Township bridges at the discretion of the CEAO Schedule Coordinator. Municipalities will be scheduled when it is feasible and reasonable but are encouraged to hire a third-party snooper contractor. The local government must provide traffic control in accordance with the Maintaining Traffic Standards. The local government must provide Bridge Inspection Team Leaders that take the technical lead and are responsible for the inspection; denoted with a "LC" on the schedule.

a) Restrictions

The Local Agency representative will meet the Snooper Operator(s) at the agreed-upon facility, often the DOT County outpost or District office, in order to escort the truck onto roads and bridges that have sufficient capacity for the snooper truck. **It is expected that any bridge with a 4F1 Rating Factor (RF) between 125 and 150% should have restrictions and any between 100 and 125% shall have restrictions.** See Appendix A and B for truck footprint and axle loads. Where special routes or instructions are required the County Engineer or City Engineer/Mayor shall explicitly communicate to the Operator each bridge detailing the specific restrictions (height, weight and width), directions and detours. Such restrictions may include:

- Snooper vehicle must cross structure at walking speed.
- Maximum permitted speed on structure must not exceed 5 MPH.
- Maximum permitted speed on structure must not exceed 10 MPH.
- Maximum permitted speed on structure must not exceed 20 MPH.

- Isolation: No other vehicles are permitted on structure while Snooper is crossing or inspecting.
- *** Do not cross structure!!
- ODOT approved planking system must be used on bridge deck to better distribute wheel loadings.
- Snooper vehicle must not stop abruptly while crossing structure.
- Snooper vehicle must cross structure while centered laterally (transversely) on bridge roadway.
- No portion of vehicle and /or load is permitted to extend beyond the outermost edge of the bridge deck.

OSE personnel will support the bridge inspection program; therefore, they reserve the right to non-perform inspections already scheduled that will cause harm or damage to personnel or equipment. Conditions such as: lack of bridge capacity, obstructive power lines or tree branches, absent railroad flagger, timber decks, overpass restriction or other site conditions impeding the truck or boom/bucket flight path.

5. Engineering Firm Responsibilities

Requests in writing through the public entity that has inspection responsibility must be made in December prior to the inspection. Due to ODOT's programmatic timeline and notice-to-proceed the snooper schedule may be set before the engineering firm is given the work. Therefore, Districts are asked to estimate a number of hours or days within the schedule for bridges requiring the snooper and request in the RFP that the engineering firm provide costs for renting appropriate access equipment.

The bridge will be scheduled when it is feasible and reasonable. The Engineering Firm must provide Bridge Inspection Team Leaders that take the technical lead and are responsible for the inspection; denoted with an "EF" on the schedule.

III. Bridges Requiring a Snooper Inspection

A list of bridges requiring snooper access shall be identified. The intent of this list is to manage the snooper trucks on a needs-based criteria and to optimize the snooper truck route. The following year's list must be revisited each December.

The Team Leader should anticipate the need for access equipment. For typical Routine Inspections, access equipment may not be required. If access equipment is needed, the bridge and the snooper limitations need to be evaluated to determine if the truck can provide the required visual "hands-on" inspection and non-destructive testing of all critical members and/or components.

1. Updating AssetWise

In order to maintain the list of bridges, appropriate inventory and appraisal values must be correctly updated in AssetWise:

- Bridge coordinates - LATITUDE and LONGITUDE must be correct.
- County-Rte-SLM – The location of the bridge on the route system, including a numerical XX.XXX straight line mileage.
- Snooper Inspection – This value is populated with a Yes or No value and will be largely static, with the exception of minor updates, for the life of the bridge.
- Frequency – This value is populated with a number of months "Not to Exceed" (Figure 5) the snooper inspection cycle values will be rounded for scheduling purposes only
 - 1-year (NTE 0-18 months),
 - 2-year (NTE 19-30 months),
 - 3-year (NTE 36-42 months) or
 - 5-year (NTE 43-66 months).

- Snooper Inspection Required, Interval (Months) and Date Performed updated every snooper inspection on the SNBI form, section 6.1
- For the applicable inspection type, B.IE.12 Inspection Equipment, should have A03 coded for “Under Bridge Inspection Vehicle”

2. Bridges That Require Snooper Access

Inspecting a bridge with the Snooper truck requires several support operations and has large associated costs. Arranging schedules to meet the operational goals in all twelve districts is a demanding task. Bridges that require a Snooper inspection must meet the minimum requirements below and must be vetted by the DBE:

- Bridge spans greater than 35 feet in height or sight-distance with no access from below
- Bridges where alternative access methods would require large amounts of additional resources - *the Snooper usage is based on need not convenience. When inspectors are able to safely and reasonably access bridge components with a ladder, bucket truck, boat or other available means, the bridge should not require snooper access.*

DBE’s may remove bridges that meet the selection guidelines when a reasonable level of confidence of the bridge condition can be achieved. A statement justifying the need should be added to AssetWise under the Review Form in the text box “Inspection Procedures”. Only bridges on the Snooper List will receive a Snooper inspection.

a) Snooper inspection frequency

The Frequency is established based on the level of risk (or priority) associated with the time period selected. Note that these priorities are important when the schedule must be changed in the middle of the season:

Guidelines for a one year cycle (Priority 1)

- Non-Redundant Steel Tension Member present
- Fatigue related details (E and E’) or history or out-of-plane bending with high ADTT

- Curved bridges subject to out-of plane bending with 4 or less longitudinal main members
- Structures with components coded “Poor” or worse and are only accessible with the snooper.
- Bridges with retrofits, unusual or inaccessible features (pin and hangers, seated hinges) that require 12-month inspection per Ohio RBI policy.

Guidelines for two (Priority 2) or three year cycle (Priority 3)

- Structures with components coded “Fair” and are only accessible with the snooper.
- Fatigue related details (E and E')
- Curved bridges subject to out-of plane bending.

Guidelines for five year cycle or greater

- Structures meet the two bridge selection requirements mentioned in this section
- Do not meet the 1-year, 2-year or 3-year frequency guidelines

IV. Scheduling

The Snooper inspection season begins in the last half of March and typically ends in the last week of November (Thanksgiving). In the event one Snooper truck completes their schedule first they will likely help the second truck complete their schedule. QA follow up and scheduling is performed from November through March with the bulk of the route optimization coordination in January and February.

Each District and Local Agency must designate a primary schedule coordinator; the DBE will be the default coordinator unless delegated. This person will take an active role in coordinating the snooper list in light of PLC, NSTM due dates, unique MOT requirements, County MOT capabilities and time allotted for inspection, travel and TTC setup between bridges.



Figure10 - Deployed Bucket

The following criteria are milestones or priorities, in order, when setting the Snooper inspection schedule. After the vertical line denotes when the Operators work on the detailed route optimization:

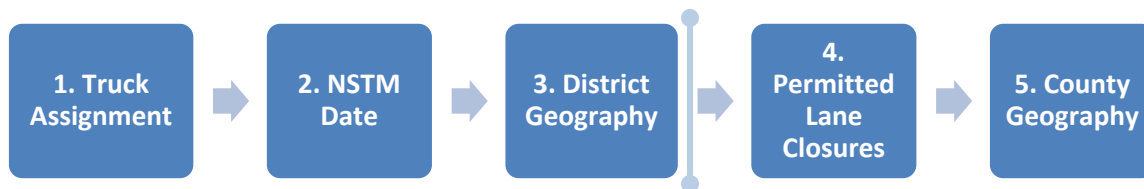

Figure 11 - Bridge Scheduling Priority

1. Truck Assignment:

Trucks requiring left-side operation must be communicated and always associated with the bridge.

2. NSTM Dates

The snoopers are utilized on the majority of ODOT's NSTM Bridges. The NSTM dates must not exceed 24 months between inspections. In order to achieve compliance these dates are followed closely and scheduled within 24-months of the previous inspection.

3. District Geography

In order to adjust for expected seasonal weather patterns both trucks start in the southern regions and move in a logical and systematic way around the state to the northern regions and finally end in the mid-to-southern regions. Both trucks are scheduled in different districts, and ideally in opposite regions of the state, in order to better respond to emergencies. The Snooper operators now begin optimizing the route and will consider cross-boundary TTC setups.

4. Permitted Lane Closures

Lane and shoulder closures are dictated by the Permitted Lane Closure maps. Night work operations are scheduled together so operators are able to safely switch between nights. An appropriate buffer is allotted for operators to switch from day to night inspections.

5. County Geography

The trucks are moved in an orderly fashion through the district avoiding back-tracking and revisiting counties. Local snooper requests are placed into the schedule depending on district location. Float days are built into the schedule, to account for inevitable but unforeseen changes to the schedule. They are often placed at the end of a district or between significant transitions. Float days will allow:

- a. Flexibility due to the weather. Acceptable cancellations due to weather include manufacturer's guidelines, lightning, hail, torrential downpour or unsafe wind-gusts
- b. Scheduled truck maintenance
- c. Transporting across large distances or travel between districts
- d. Traffic volumes and PLC's prior to a holiday weekend

- e. Report Time for “CO” inspections
- f. Make-up inspections
- g. Schedule training

With the exception of large urban centers, the Snooper should not revisit or have the second Snooper visit in any one year. The number of Counties is limited, and when advantageous, County TA’s are asked to permit crews to cross county or even district boundaries.

5. Timeline

a) November

The schedule is verified and opportunities for improvement are discussed with Administrators, Bridge Engineers and Bridge Inspectors. Districts and local agencies designate a primary schedule coordinator.

- Schedule Annual Aspen Aerials inspection with Office of Equipment Management for December 15th.
- E mail master list in the last week of November to district schedule coordinator requesting *verification* and *modification* for consultant inspected bridges and corrections to the master list by December 15th.
- E mail master list in the last week of November to CEAO schedule coordinator requesting *verification* and *modification* for consultant inspected bridges and corrections to the master list by December 15th
 - *Verification*: The bridges, NSTM dates, PLC’s and the safest routes to the bridge must be verified thoroughly in order to limit undue back-and-forth communications that negatively affect all districts’ inspection programs.
Inaccuracies in the bridge list at this stage may result in non-performing the snooper inspection. Specific guidance must be communicated where clearance or load posting restrictions exist on or traveling to the site. The list is generated based on the assigned frequency and the last recorded time the structure received a snooper inspection from time management records.
 - *Modification*: If bridges need to be added or the list needs modified, coordinators must provide accurate information. The information must include:

- SFN
- Latitude and Longitude – correct in AssetWise
- Bridge Number
- Snoopers Inspection Frequency
- Feature intersection
- Type of Inspection to be performed
- NSTM Inspection Procedure
- Maintaining Traffic Standard Construction Drawing (MT-SCD) Reference
- Maintenance of Traffic restrictions (including PLC, unique setups, night work)
- Contact name and number for traffic control
- Estimated snoopers inspection time (hrs.) including time for maintenance of traffic set-up
- Lead Inspector (DT, LC, EF, CO, SH)
- Contact name and number for inspection
- Truck Required, not preference (leave blank if either truck can reach)

b) December

December 15th is the cutoff for the next year’s schedule verification. The master list is verified by OSE and discussed with Districts potential additions or subtractions.

c) January

Truck assignments are made as a group in light of District and County geography, NSTM dates and Permitted Lane Closure restrictions. OSE will provide data for map-making.

Operators will take bridges assigned to their truck and work on optimizing a route.

Optimization includes discussing with District bridge inspectors, District Bridge Engineers, County managers, determining available resources and performing site visits.

d) February

Operators will put together the optimized schedule and confirm with the Bridge Inspection Engineer. The schedule will be shared with the schedule coordinators by February 15th for review. The schedule **must be reviewed** in light of inspection time, RR Permits, geography, MOT restrictions and County MOT capabilities. Minor adjustments are acceptable but significant changes, additions or movement would likely result in non-performing the inspections with the snooper.

e) March

After vetting any challenges with the schedule the confirmed final list of bridge and dates will be re-sent to the schedule coordinators and posted on the OSE website by the first Friday of March.

Districts Schedule Coordinators must share with the Public Information Officer, District Highway Management Administrator, District Bridge Engineer, County Managers, Municipal MOT, District Bridge Specialists, Engineering Firm and anyone else affected by the snooper operations.

Implementing the schedule begins on the second or third Monday of March.

6. Changes to the Schedule

Changing the schedule is a decision that must take into account public safety, the economics of a multi-faceted operation and the complications associated with affecting several entities statewide mid-schedule. OSE is committed to maintaining the established snooper schedule, submitted in March, with minimal disruption to other Counties or Districts. However, operational need may require the Bridge Inspection Engineer to move the snooper to other Districts or Counties ahead, behind or not scheduled i.e. comprehensive changes (Figure 14).

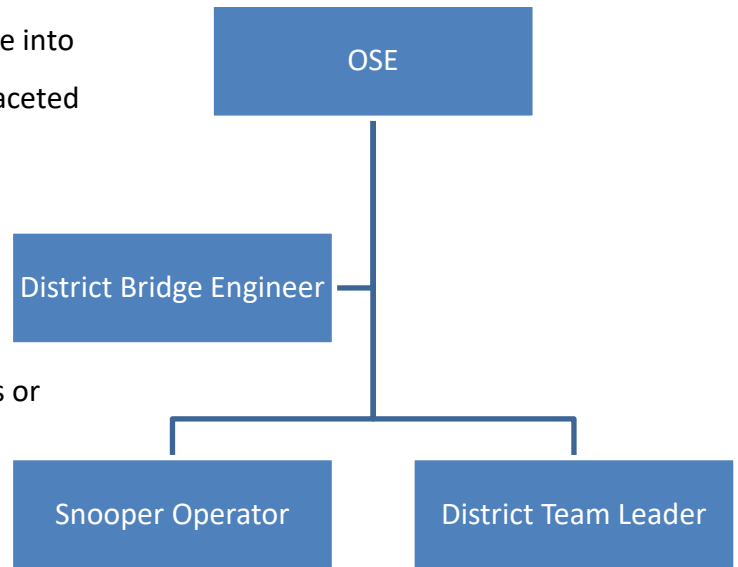

Figure 12 - Authority for Comprehensive Changes to Snooper Schedule

Snooper Operators are committed to supporting the bridge inspection program as well. They are most familiar with the trucks and on a case-by-case basis they reserve the right to deny schedule changes or non-perform inspections on bridges that have already been scheduled that would potentially cause damage or impairment to personnel or equipment. Conditions such as: lack of bridge capacity based on load ratings, obstructive power lines or tree branches, absent railroad flagger, overpass restriction, oversights from the schedule coordinator, fence height or other site conditions impeding the inspectors, truck or boom/bucket flight path.

Statewide: As previously mentioned, comprehensive changes to the schedule may be required and the authority for such changes is within the Office of Structural Engineering. The following two scenarios may cause a wide-ranging alteration in the schedule:

1. Unscheduled Emergencies where the Snooper is the only option for inspection or maintenance in order to return serviceability to a high priority state route on the National Highway System

2. Special inspections that may be identified with construction, research or special investigations Nationally or within the State (ex. Gusset Plates, Pin & Hanger, Fatigue Connections, Protective coating systems)

Within the District: In the event of weather delays, truck maintenance or unforeseen complications hinder an inspection. Then the District Bridge Engineer has the authority to ‘triage’ their higher priority inspections and save the lower-priority inspections for the next inspection cycle. The highest priority bridges that shall be inspected are those bridge inspections on state routes that require snoopers access and directly affect Federal and State compliance:

- NSTM inspections NTE 24 months that are ‘due’ that cycle
- Annual Snooper Cycle Inspections (1-year)
- Scheduled, paid and permitted Railroad Flagging for Bridges on the 2-year cycle

Most of the time float days will be utilized to account for minor fluctuations. If the scheduled float days cannot accommodate the unforeseen changes even when performing the highest priority inspections, then adjustments to the next District may be necessary. This must be communicated as soon as reasonable to the OSE Bridge Inspection Engineer for consideration. The next scheduled District may have to adjust and triage their priority structures as well or, when applicable, the second snooper truck may have to add the non-performed highest priority inspections when in the district.

If the District schedule goes faster than planned, then next years’ Snooper cycle may be added to the schedule. These bridges may **not** be added to the Float days but rather to days already scheduled. This must be a team decision, with the final determination made by the District Bridge Engineer, and the decision shall incorporate the following:

- Logical movement of the snooper trucks (geography and route optimization)
- Compliance
- Snooper operators
- District inspectors

- County work plan

The following bridges shall take priority when adding them to the schedule:

1. Bridges on State Routes on the Snooper List
2. NSTM Inspections due in the next annual cycle
3. Inspections or maintenance where the Snooper is the only option to access a component affecting public safety on the state right-of-way or in changing or 4-Poor condition.

Within the County: Minor adjustments to the schedule are anticipated within the county and should be made as a team. Modifications may be expected when scheduled inspections are non-performed due to construction or traffic patterns. The Team Leader has the authority to make these adjustments. Changes that improve efficiency, add value and are reasonable at the County level are welcomed and encouraged.

Appendix A

62-foot Snooper Flight Diagram and Footprint

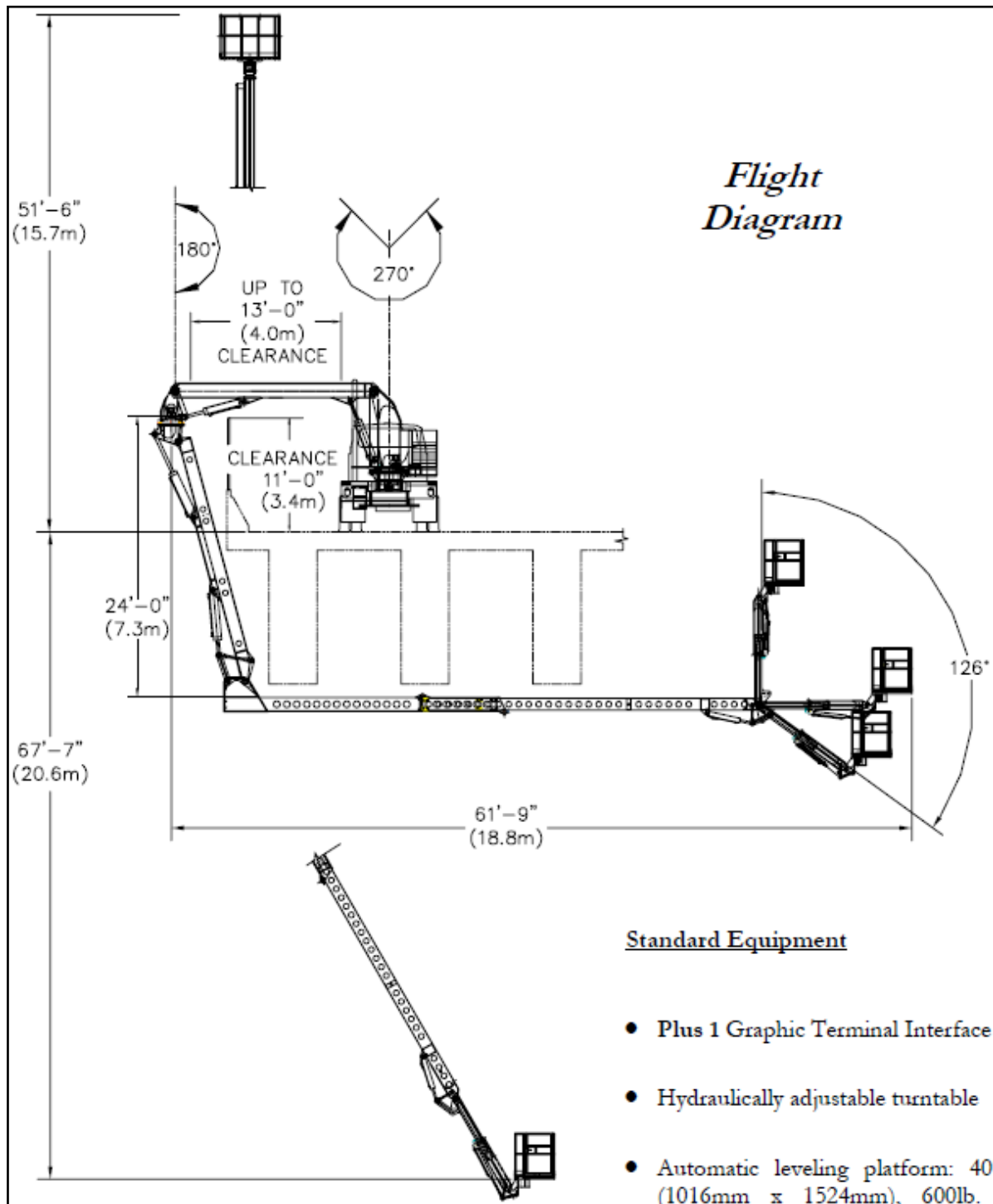

A62 Axle Load

VEHICLE: 2019 KENWORTH T880
 VIN: 1NKZX4TX8KJ359028
 ASPEN S/N : 10328

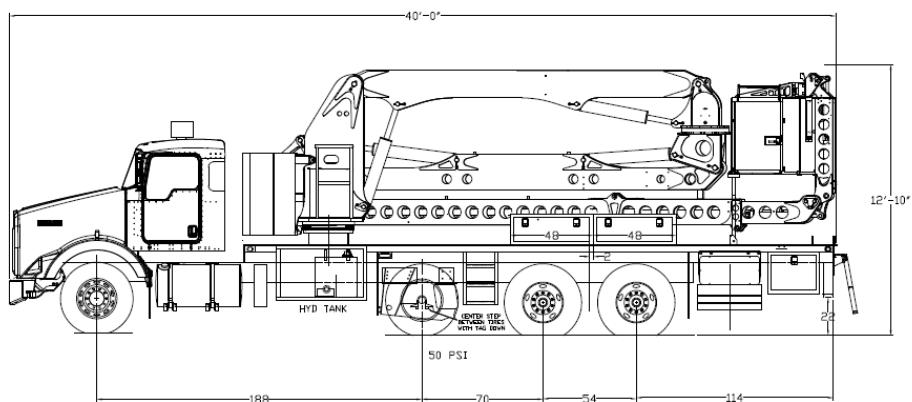

ESTIMATED FRONT AXLE WEIGHT 18,960 LB	ESTIMATED TOTAL CURB WEIGHT 65,600 LB	ESTIMATED LIFT AXLE WEIGHT 12,920 LB	ESTIMATED TANDEM AXLE WEIGHT 33,720 LB
TIRES (2) 425/65R22.5		TIRES (4) 295/75R22.5	TIRES (8) 11R22.5G

INDIVIDUAL AXLE WEIGHTS MAY VARY +/- 2% OF FIGURE SHOWN

DO NOT SCALE THIS DRAWING		ASPEN AERIALS <small>INC.</small>	
THIS DRAWING IS THE PROPERTY OF ASPEN AERIALS, INC. IT IS TO BE USED ONLY FOR THE PROJECT AND SITE SPECIFICALLY IDENTIFIED HEREON. IT IS NOT TO BE REPRODUCED, COPIED, OR TRANSMITTED IN ANY FORM OR BY ANY MEANS, ELECTRONIC OR MECHANICAL, INCLUDING PHOTOCOPYING, RECORDING, OR BY ANY INFORMATION STORAGE AND RETRIEVAL SYSTEM, WITHOUT THE WRITTEN PERMISSION OF ASPEN AERIALS, INC.		WEIGHT DRAWING DHID DOT A62 REMOUNT	
DATE: 08/20/2019	BY: [Signature]	SCALE: 1/2" = 1'-0"	SHEET NO: 10328

VEHICLE: 2021 KENWORTH T880
 VIN: 1NKZX4TX3MJ470461
 ASPEN S/N : 10147

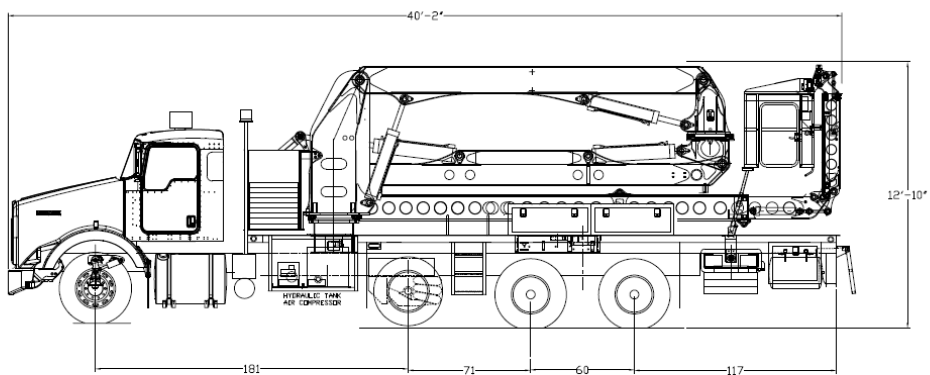

ESTIMATED STEER AXLE WEIGHT 18,760 LB	ESTIMATED TOTAL CURB WEIGHT 65,340 LB	ESTIMATED LIFT AXLE WEIGHT 11,420 LB	ESTIMATED TANDEM AXLE WEIGHT 35,160 LB
TIRES (2) 425/65R22.5		TIRES (4) 295/75R22.5	TIRES (8) 11R22.5G

INDIVIDUAL AXLE WEIGHTS MAY VARY +/- 2% OF FIGURE SHOWN

DO NOT SCALE THIS DRAWING		ASPEN AERIALS <small>INC.</small>	
THIS DRAWING IS THE PROPERTY OF ASPEN AERIALS, INC. IT IS TO BE USED ONLY FOR THE PROJECT AND SITE SPECIFICALLY IDENTIFIED HEREON. IT IS NOT TO BE REPRODUCED, COPIED, OR TRANSMITTED IN ANY FORM OR BY ANY MEANS, ELECTRONIC OR MECHANICAL, INCLUDING PHOTOCOPYING, RECORDING, OR BY ANY INFORMATION STORAGE AND RETRIEVAL SYSTEM, WITHOUT THE WRITTEN PERMISSION OF ASPEN AERIALS, INC.		WEIGHT DRAWING DHID DOT A62 REMOUNT	
DATE: 08/20/2019	BY: [Signature]	SCALE: 1/2" = 1'-0"	SHEET NO: 10147